

# SM24xx Series

Multi-standard power line communications modem

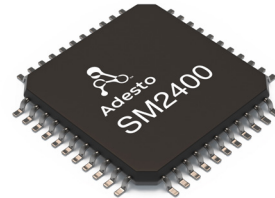

## Universal Modem Chip

**Comprehensive multi-standard platform,  
superior noise performance, low system cost**

**G3-PLC**  
Alliance

**PRIME**  
ALLIANCE®

 **IEEE**

 **SUNSPEC**  
ALLIANCE

Establish a communications network with existing installed power lines!  
The SM2400/SM2480 is the ultimate Narrowband Power Line Communication (N-PLC) modem that combines cost effective design optimized for PLC applications with high flexibility to address industry standard protocols, future new standards and high robust proprietary modes.

### SM2400

**Configurable power line communications modem**

**System-On-Chip (SOC)**

Data rates up to 400kbps

Configurable operational bands (5 - 500 kHz)

- CENELEC
- ARIB
- FCC

Supports OFDM, BPSK for superior communication

Comprehensive multi-standard capability

- PRIME
- IEEE 1901.2
- G3-PLC
- Proprietary XXR

32-bit dual core highly flexible and programmable architecture

- PHY (Physical Layer)
- MAC (Media Access Controller)

High-speed 256-bit AES-CCM for secure communications

Cost optimized integrated analog front-end (AFE)

**Peripheral Interfaces**

Interfaces for adding optional components

- UART
- JTAG
- SPI
- GPIO

### SM2480

**Grid connected micro-inverter and lighting controller**

Includes all SM2400 features with additional analog signal control functions

Extremely flexible PWM controller with up to 300kHz with 10ns resolution designed for fast and flexible signal adjustments

Uniquely capable platform for MPPT and other control algorithms

High precision dual ADCs

4 High speed programmable comparators for fault detection

5 High speed DACs



**Adesto**

# APPLICATIONS

- Smart grid communications
- Advanced Metering Infrastructure (AMI)
- Automated Meter reading (AMR)
- Street lighting control and smart ballasts
- Solar and alternative energy management
- Smart home energy monitoring
- Factory and Building Automation (BA)
- Supervisory Control and Data Acquisition (SCADA)

## Extremely Robust XXR Mode

Extremely robust communication adapted for power line noise profile

Up to 4 independent channels (carriers) placed anywhere in the spectrum

- Optimized frequency placement based on noise and impedance environment

Channels can be used for redundancy (diversity) by sending same data

- Data combined in optimal manner
- Correct data reception only requires one good channel or one combination of channels

Every channel is RS coded and includes CRC

Capable of extended ranges up to several kilometers

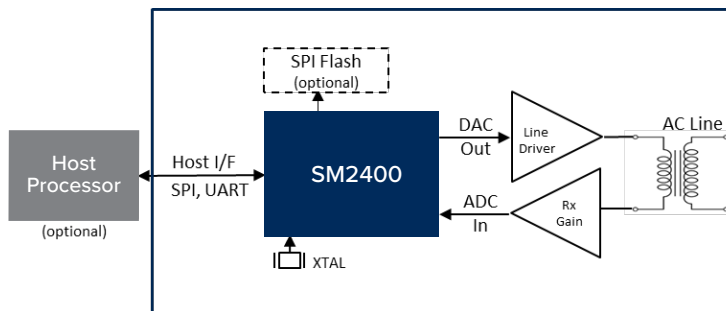

Block diagram of SM2400 modem interface solution

## Additional Support Features

### SMESH: "Simple Mesh" Protocol

Designed for solar, lighting and small metering deployments

Self-healing and discovery

Limited number of nodes (< 100)

Simple network management and firmware update

### Serial-to-PLC Bridging

RS232 extension and RS485 replacement

Data and command modes (ASCII or TP pass-through)

MODBUS

### SunSpec Compliance

Rapid Shutdown compliant (NEC 2017) with interleaved PLC Communications

## Rapid Evaluation and Development

### Hardware

Plug-in module(s) optimized for FCC, CEN-A and CEN-BC

Mini USB connection

IEC power connection

Built-in power line coupling circuit

Ability to bypass on board switched-mode power supply and use external DC supply

### Software

Programmable/downloadable firmware

- PRIME / G3 / IEEE 1901.2 / XXR

Unified development framework and tools for all firmware packages

Unified serial host protocol allowing direct interface to MACs, PHYs, CLs

Unified GUI for testing and experimentation

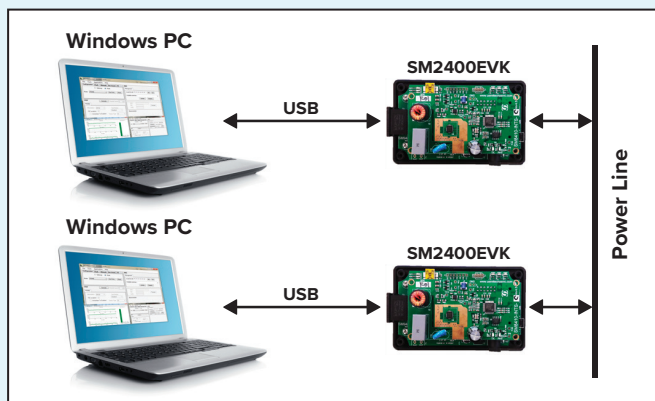

Evaluation kits are available to run communications testing via a powerline and PCs. EVK Part Number: SM2400-EVK2-Mn-x



## Данный компонент на территории Российской Федерации

### Вы можете приобрести в компании MosChip.

Для оперативного оформления запроса Вам необходимо перейти по данной ссылке:

<http://moschip.ru/get-element>

Вы можете разместить у нас заказ для любого Вашего проекта, будь то серийное производство или разработка единичного прибора.

В нашем ассортименте представлены ведущие мировые производители активных и пассивных электронных компонентов.

Нашей специализацией является поставка электронной компонентной базы двойного назначения, продукции таких производителей как XILINX, Intel (ex.ALTERA), Vicor, Microchip, Texas Instruments, Analog Devices, Mini-Circuits, Amphenol, Glenair.

Сотрудничество с глобальными дистрибьюторами электронных компонентов, предоставляет возможность заказывать и получать с международных складов практически любой перечень компонентов в оптимальные для Вас сроки.

На всех этапах разработки и производства наши партнеры могут получить квалифицированную поддержку опытных инженеров.

Система менеджмента качества компании отвечает требованиям в соответствии с ГОСТ Р ИСО 9001, ГОСТ РВ 0015-002 и ЭС РД 009

### Офис по работе с юридическими лицами:

105318, г.Москва, ул.Щербаковская д.3, офис 1107, 1118, ДЦ «Щербаковский»

Телефон: +7 495 668-12-70 (многоканальный)

Факс: +7 495 668-12-70 (доб.304)

E-mail: [info@moschip.ru](mailto:info@moschip.ru)

Skype отдела продаж:

moschip.ru

moschip.ru\_4

moschip.ru\_6

moschip.ru\_9