

## Li-Ion linear battery charger with LDO

Datasheet - production data

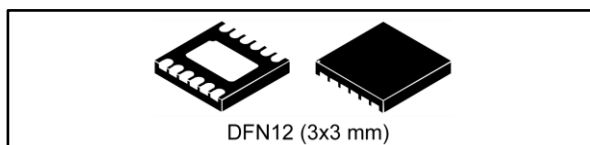

### Features

- Charges single-cell Li-Ion batteries with CC/CV algorithm and charge termination
- Charge current programmable up to 200 mA
- 1% accuracy on floating voltage (4.2 V)
- Integrated 3.1 V LDO regulator
- Automatic power path management
- Battery overcharge protection
- Battery over-discharge protection
- Battery overcurrent protection
- Charging timeout
- Very low battery leakage in over-discharge/shutdown mode
- Low quiescent current
- Charge/fault status output
- Charger enable input
- Available in a DFN12L (3x3x0.75 mm) package

### Applications

- Portable MP3 players
- Portable low-power devices
- Fitness portable devices

### Description

The STNS01 is a linear charger for single-cell Li-Ion batteries integrating an LDO regulator and several battery protection functions.

The STNS01 uses a CC/CV algorithm to charge the battery; the fast-charge current can be programmed using an external resistor. Pre-charge current and termination current are scaled accordingly. The floating voltage value is 4.2 V.

The input supply voltage is normally used to charge the battery and provide power to the LDO regulator. When a valid input voltage is not present and the battery is not empty, the device automatically switches to battery power.

The STNS01 integrates overcharge, over-discharge and overcurrent protection circuitry to prevent the battery from being damaged under fault conditions. It also features a charger enable input to stop the charging process when battery overtemperature is detected by an external circuitry.

When the shutdown mode is activated, the battery power consumption is reduced to less than 500 nA to maximize battery life during shelf time or shipping. The device is available in the DFN12L (3x3x0.75 mm) package.

**Table 1: Device summary**

Order code	Package	Packing
STNS01PUR	DFN12L (3x3x0.75 mm)	3000 parts per reel

## Contents

<b>1</b>	<b>Application schematic .....</b>	<b>6</b>
<b>2</b>	<b>Block diagram.....</b>	<b>7</b>
<b>3</b>	<b>Pin configuration .....</b>	<b>8</b>
<b>4</b>	<b>Maximum ratings .....</b>	<b>9</b>
<b>5</b>	<b>Electrical characteristics .....</b>	<b>10</b>
<b>6</b>	<b>Typical performance characteristics (curves).....</b>	<b>13</b>
6.1	IN .....	15
6.2	SYS.....	15
6.3	LDO.....	15
6.4	SD .....	15
6.5	CHG .....	16
6.6	CEN .....	16
6.7	GND .....	17
6.8	NTC.....	17
6.9	ISET .....	17
6.10	BATMS.....	17
6.11	BATSNS.....	18
6.12	BAT .....	18
<b>7</b>	<b>Operation description .....</b>	<b>19</b>
7.1	Power-on.....	19
7.2	Battery charger.....	19
7.3	Battery temperature monitoring.....	21
7.4	Battery overcharge protection .....	22
7.5	Battery over-discharge protection .....	22
7.6	Battery discharge overcurrent protection .....	22
7.7	Input overcurrent protection .....	22
7.8	SYS and LDO short-circuit protection .....	23
7.9	IN overvoltage protection .....	23
7.10	Shutdown mode .....	23
7.11	Thermal shutdown.....	23
7.12	Reverse current protection .....	23
<b>8</b>	<b>Package information .....</b>	<b>24</b>

---

8.1	DFN12L (3x3x0.75 mm) package information.....	24
8.2	DFN12L (3x3x0.75 mm) packing information.....	26
<b>9</b>	<b>Revision history .....</b>	<b>28</b>

## List of tables

Table 1: Device summary .....	1
Table 2: List of external components .....	6
Table 3: Pin description .....	8
Table 4: Absolute maximum ratings .....	9
Table 5: Thermal data .....	9
Table 6: Electrical characteristics .....	10
Table 7: SYS pin voltage .....	15
Table 8: CHG pin state .....	16
Table 9: DFN12L (3x3x0.75 mm) package mechanical data .....	25
Table 10: Document revision history .....	28

## List of figures

Figure 1: STNS01 application schematic.....	6
Figure 2: STNS01 block diagram.....	7
Figure 3: Pin configuration (top view) .....	8
Figure 4: Start-up .....	13
Figure 5: Start - up VBAT = 0 V .....	13
Figure 6: Input OVP .....	13
Figure 7: IPRE-CHG to IFAST-CHG.....	13
Figure 8: Plug USB .....	14
Figure 9: Unplug USB (battery powered).....	14
Figure 10: RON-BS vs. temperature.....	14
Figure 11: Battery voltage vs. charge current.....	14
Figure 12: Load transient LDO pre-chg .....	14
Figure 13: Load transient LDO fast-chg.....	14
Figure 14: VLDO vs. temperature .....	15
Figure 15: VLDO load static regulation .....	15
Figure 16: Shutdown mode entry and exit (not to scale, deglitch times not included) .....	16
Figure 17: Charge disable / enable.....	17
Figure 18: Charging flowchart.....	20
Figure 19: CC-CV charging profile (not to scale).....	21
Figure 20: Charging cycle profile .....	21
Figure 21: Discharging cycle profile.....	22
Figure 22: DFN12L (3x3x0.75 mm) package outline .....	24
Figure 23: DFN12L (3x3x0.75 mm) recommended footprint .....	25
Figure 24: Tape outline .....	26
Figure 25: Reel outline .....	27

# 1 Application schematic

Figure 1: STNS01 application schematic

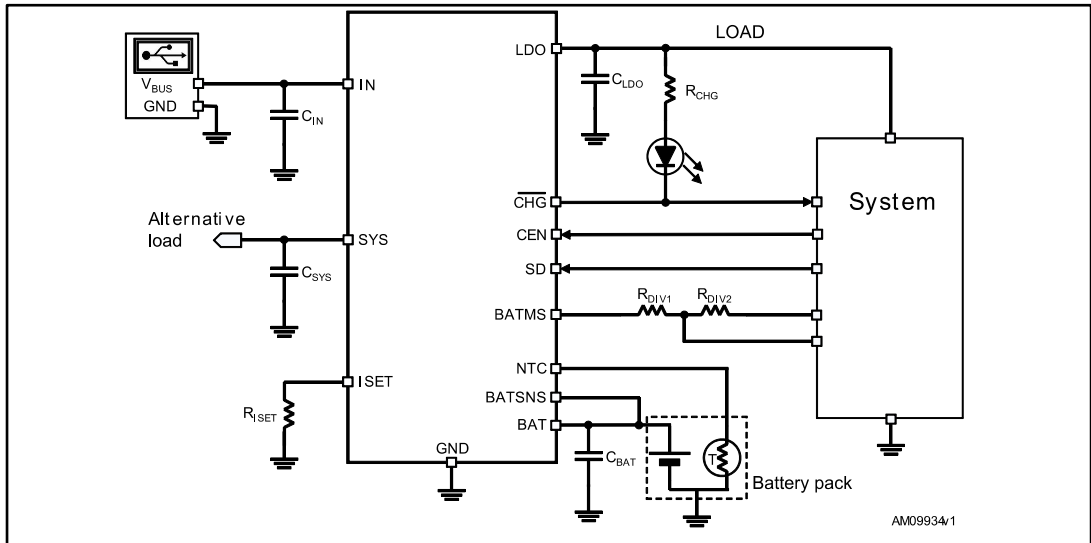
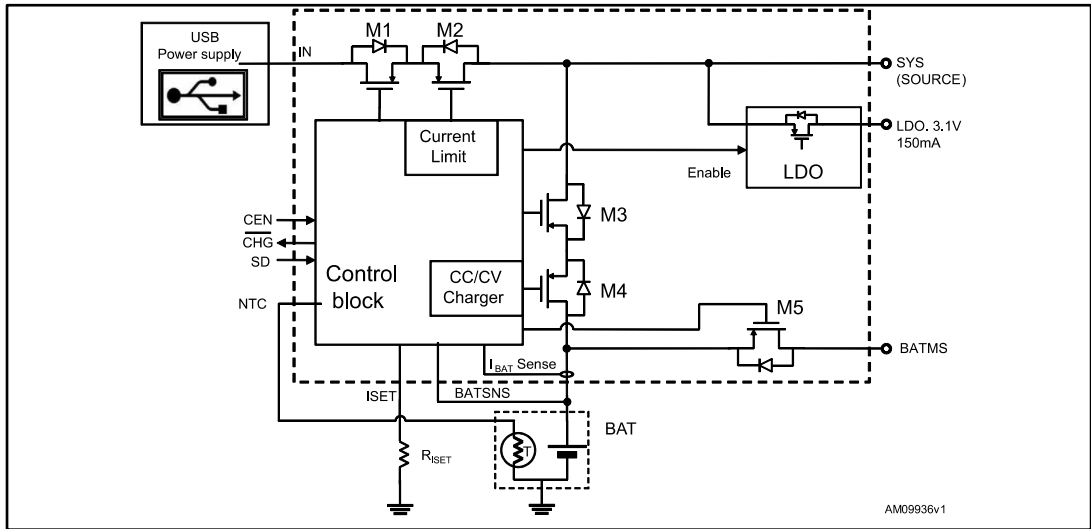

Table 2: List of external components

Symbol	Manufacturer	Value	Description	Size
C <sub>IN</sub>	Murata	2.2 μF	GRM188R71A225KE15D	0603
C <sub>SYS</sub>	Murata	2.2 μF	GRM188R71A225KE15D	
C <sub>LDO</sub>	Murata	2.2 μF	GRM188R71A225KE15D	
R <sub>ISET</sub>	Any	1 kΩ – 13 kΩ	Resistor	
C <sub>BAT</sub>	Murata	4.7 μF	GRM188R61A475KE15D	
D1	Any		Diode led	
R <sub>DIV1, DIV2</sub>	Any		Depending on the BATMS status	
R <sub>CHG</sub>	Any	600 Ω	Resistor	
C <sub>LDO</sub>		2.2 μF	GRM188R71A225KE15D	

## 2 Block diagram

Figure 2: STNS01 block diagram



### 3 Pin configuration

Figure 3: Pin configuration (top view)

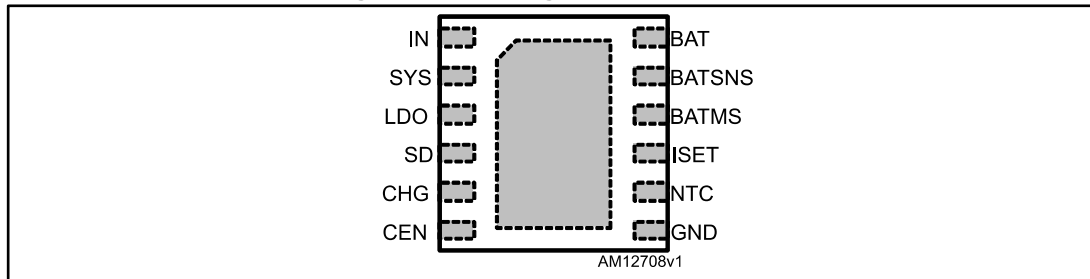

Table 3: Pin description

Pin name	Number	Description
IN	1	Input supply voltage. Bypass this pin to ground with a 2.2 $\mu$ F capacitor
SYS	2	System output. Bypass this pin to GND with a 2.2 $\mu$ F ceramic capacitor
LDO	3	3.1 V LDO output. Bypass this pin to ground with a 1 $\mu$ F ceramic capacitor
SD	4	Shutdown. Active high. 500 k $\Omega$ internal pull-down
CHG	5	Charging/fault flag. Active low
CEN	6	Charger enable pin. Active high. 500 k $\Omega$ internal pull-up (to LDO)
GND	7	Ground
NTC	8	Battery temperature monitor pin
ISET	9	Fast-charge programming resistor
BATMS	10	Battery voltage measurement pin
BATSNS	11	Battery voltage sensing. Connect as close as possible to the battery positive terminal
BAT	12	Battery positive terminal. Bypass this pin to GND with a 4.7 $\mu$ F ceramic capacitor
Exposed pad		Connect to GND



## 4 Maximum ratings

Table 4: Absolute maximum ratings

Symbol	Parameter	Test conditions	Value	Unit
V <sub>IN</sub>	Input supply voltage pin	DC voltage	-0.3 to +10.0	V
		Non repetitive, 60 s pulse length	-0.3 to +16.0	V
V <sub>LDO</sub>	LDO output pin voltage	DC voltage	-0.3 to +4.0	V
V <sub>SYS</sub>	SYS pin voltage	DC voltage	-0.3 to +6.5	V
V <sub>CHG</sub>	CHG pin voltage	DC voltage	-0.3 to +6.5	V
V <sub>LGC</sub>	Voltage on logic pins (CEN, SD)	DC voltage	-0.3 to +4.0	V
V <sub>ISET</sub>	Voltage on ISET pin	DC voltage	-0.3 to +2	V
V <sub>NTC</sub>	Voltage on NTC pin	DC voltage	-0.3 to 3.1	V
V <sub>BAT</sub> , V <sub>BATSNS</sub>	Voltage on BAT, BATSNS pins	DC voltage	-0.3 to +5.5	V
V <sub>BATMS</sub>	Voltage on BATMS pin	DC voltage	-0.3 to V <sub>BAT</sub> +0.3	V
ESD	Human body model	JS-001-2010	±2000	V
T <sub>AMB</sub>	Operating ambient temperature		-40 to +85	°C
T <sub>J</sub>	Maximum junction temperature		+125	°C
T <sub>STG</sub>	Storage temperature		-65 to +150	°C



Absolute maximum ratings are those values beyond which damage to the device may occur. Functional operation under these conditions is not implied.

Table 5: Thermal data

Symbol	Parameter	Value	Unit
R <sub>thJA</sub>	Thermal resistance junction-ambient	49	°C/W
R <sub>thJC</sub>	Thermal resistance junction-case	4.2	

## 5 Electrical characteristics

The values given in the following table are valid for  $-40\text{ }^{\circ}\text{C} < T_J < +85\text{ }^{\circ}\text{C}$ ,  $V_{IN} = 5\text{ V}$ ,  $V_{BAT} = 3.6\text{ V}$ ,  $C_{LDO} = 1\text{ }\mu\text{F}$ ,  $C_{BAT} = 4.7\text{ }\mu\text{F}$ ,  $C_{IN} = C_{SYS} = 2.2\text{ }\mu\text{F}$ ,  $R_{ISET} = 1\text{ k}\Omega$ ,  $SD = \text{low}$ ,  $CEN = \text{high}$ , unless otherwise specified.

**Table 6: Electrical characteristics**

Symbol	Parameter	Test conditions	Min.	Typ.	Max.	Unit
$V_{IN}$	Operating input voltage	$V_{IN}$ rising	4.55		5.4	V
$V_{INOVP}$	Input overvoltage protection	$V_{IN}$ rising	5.6	5.9	6.2	V
$V_{INOVP\text{H}}$	Input overvoltage protection hysteresis	$V_{IN}$ falling		200		mV
$V_{UVLO}$	Undervoltage lock-out	$V_{IN}$ falling	3.95	4.18	4.35	V
$V_{UVLO\text{H}}$	Undervoltage lock-out hysteresis	$V_{IN}$ rising		300		mV
$I_{IN}$	IN supply current	Charger disabled mode ( $CEN = \text{low}$ ), $I_{SYS} = I_{LDO} = 0\text{ A}$		400		$\mu\text{A}$
		Charging, $V_{HOT} < V_{NTC} < V_{COLD}$ , including $R_{ISET}$ current		1.4		mA
$V_{FLOAT}$	Battery floating voltage	$I_{BAT} = 1\text{ mA}$	4.158	4.2	4.242	V
$I_{BAT}$	BAT pin supply current	Battery-powered mode ( $V_{IN} < V_{UVLO}$ ), $I_{LDO} = 0\text{ A}$		6	10	$\mu\text{A}$
		Standby mode, charge terminated		6	10	$\mu\text{A}$
		Shutdown mode ( $SD = \text{high}$ )		100	500	nA
		Over-discharge mode ( $V_{BAT} < V_{ODC}$ , $V_{IN} < V_{UVLO}$ )		100	500	
$I_{FAST}$	Fast-charge current	$R_{ISET} = 500\text{ }\Omega$ , constant-current mode $I_{LDO} + I_{SYS} < 100\text{ mA}$		400		mA
		$R_{ISET} = 1\text{ k}\Omega$ , constant-current mode	180	200	220	
		$R_{ISET} = 13\text{ k}\Omega$ , constant-current mode	12	15	18	
$R_{ISET}$	Fast-charge programming resistor range		1		13	k $\Omega$
$V_{ISET}$	$I_{SET}$ regulated voltage			1		
$V_{PRE}$	Pre-charge to fast-charge battery voltage threshold	Charger active		3		V
$I_{PRE}$	Pre-charge current	$V_{BAT} < 3\text{ V}$ , charger active		20		% $I_{FAST}$
$I_{END}$	End-of-charge current	Charging in CV mode		10		% $I_{FAST}$
$V_{OCHG}$	Battery voltage overcharge threshold	$V_{BAT}$ rising	4.245	4.275	4.305	V
$V_{ODC}$	Battery voltage over-discharge threshold	$V_{IN} < V_{UVLO}$ , $I_{LDO} = 100\text{ mA}$	2.750	2.8	2.850	V
$V_{ODCR}$	Battery voltage over-discharge release threshold			3.0		V

Symbol	Parameter	Test conditions	Min.	Typ.	Max.	Unit
R <sub>ON-IB</sub>	Input to battery on-resistance			1	1.5	Ω
R <sub>ON-BS</sub>	Battery to SYS on-resistance	I <sub>SINK</sub> = 100 mA		0.38	0.55	Ω
R <sub>ON-BATMS</sub>	BATSNS to BATMS on-resistance	I <sub>SINK</sub> = 500 μA		270		Ω
V <sub>OL</sub>	Output low level (CHG)	I <sub>SINK</sub> = 5 mA			0.4	V
V <sub>IL</sub>	Logic low input level (CEN, SD)	V <sub>LDO</sub> = 3.1 V			0.4	V
V <sub>IH</sub>	Logic high input level (CEN, SD)		1.6			V
R <sub>UP</sub>	CEN pull-up resistor		375	500	625	kΩ
R <sub>DOWN</sub>	SD pull-down resistor		375	500	625	kΩ
V <sub>LDO</sub>	LDO output voltage	I <sub>LDO</sub> = 1 mA	3.007	3.1	3.193	V
ΔV <sub>OUT-LOAD</sub>	LDO static load regulation	I <sub>LDO</sub> = 1 mA to 150 mA		±0.002		%/mA
I <sub>SC</sub>	LDO short-circuit current	R <sub>LOAD</sub> = 0 Ω	250	350		mA
I <sub>BATOCP</sub>	Battery discharge overcurrent protection	V <sub>IN</sub> < V <sub>UVLO</sub> (powered from BAT)	400		650	mA
I <sub>INLIM</sub>	Input current limitation	V <sub>SYS</sub> > V <sub>ILIMSCTH</sub> ; V <sub>UVLO</sub> < V <sub>IN</sub> < V <sub>INOVP</sub> (powered from IN)		1		A
I <sub>INIMSCTH</sub>	Input current limitation in short-circuit conditions	V <sub>SYS</sub> < V <sub>ILIMSCTHINOVP</sub> (powered from IN)		400		mA
V <sub>ILIMSCTH</sub>	SYS voltage threshold for input current limitation short-circuit detection	V <sub>UVLO</sub> < V <sub>IN</sub> < V <sub>INOVP</sub>		2		V
V <sub>SCLDO</sub>	LDO short-circuit protection threshold	V <sub>IN</sub> < V <sub>UVLO</sub> or V <sub>IN</sub> > V <sub>INOVP</sub> (powered from BAT)		0.7		V
V <sub>SCSYS</sub>	SYS short-circuit protection threshold	V <sub>IN</sub> < V <sub>UVLO</sub> or V <sub>IN</sub> > V <sub>INOVP</sub> (powered from BAT)		V <sub>BAT</sub> - 0.8		V
I <sub>NTCB</sub>	NTC pin bias current	V <sub>NTC</sub> = 0.25 V	48	50	52	μA
V <sub>HOT</sub>	Thermal hot threshold	Increasing NTC temperature	0.234	0.246	0.258	V
V <sub>COLD</sub>	Thermal cold threshold	Decreasing NTC temperature	1.28	1.355	1.43	V
T <sub>HYST</sub>	Hot/cold temperature threshold hysteresis	10 kΩ NTC, β = 3370		3		°C
T <sub>SD</sub>	Thermal shutdown die temperature			180		°C
T <sub>FAULT</sub>	CHG pin blinking frequency	Fault condition		1		Hz
t <sub>CHGD</sub>	Input voltage connection to charging-start delay	V <sub>BAT</sub> = 3.5 V, R <sub>NTC</sub> = 10 kΩ, battery detection not included (t <sub>BDSRC</sub> + t <sub>BDSNK</sub> )		240		ms
t <sub> OCD</sub>	Overcharge detection delay	V <sub>BAT</sub> > V <sub>OCHG</sub> , V <sub>UVLO</sub> < V <sub>IN</sub> < V <sub>INOVP</sub>		1.2		s
t <sub>ODD</sub>	Over-discharge detection delay	V <sub>BAT</sub> < V <sub>ODC</sub> and V <sub>IN</sub> < V <sub>UVLO</sub> or V <sub>IN</sub> > V <sub>INOVP</sub>		400		ms

## Electrical characteristics

STNS01

Symbol	Parameter	Test conditions	Min.	Typ.	Max.	Unit
t <sub>DOD</sub>	Discharge overcurrent detection delay	I <sub>BAT</sub> > I <sub>BATOCP</sub> , V <sub>IN</sub> < V <sub>UVLO</sub> or V <sub>IN</sub> > V <sub>INOVP</sub>		14		ms
t <sub>PF</sub>	Pre-charge to fast-charge transition deglitch time	Rising		100		ms
t <sub>FP</sub>	Fast-charge to pre-charge fault deglitch time			10		ms
t <sub>END</sub>	End-of-charge deglitch time			100		ms
t <sub>PRE</sub>	Pre-charge timeout	V <sub>BAT</sub> < V <sub>PRE</sub> , charging		1800		s
t <sub>FAST</sub>	Fast-charge timeout			36000		s
t <sub>NTCD</sub>	Battery temperature transition deglitch time			100		ms
t <sub>PW</sub>	CEN/SD valid input pulse width		30			ms
t <sub>THPD</sub>	Thermal protection deglitch time			10		ms

## 6 Typical performance characteristics (curves)

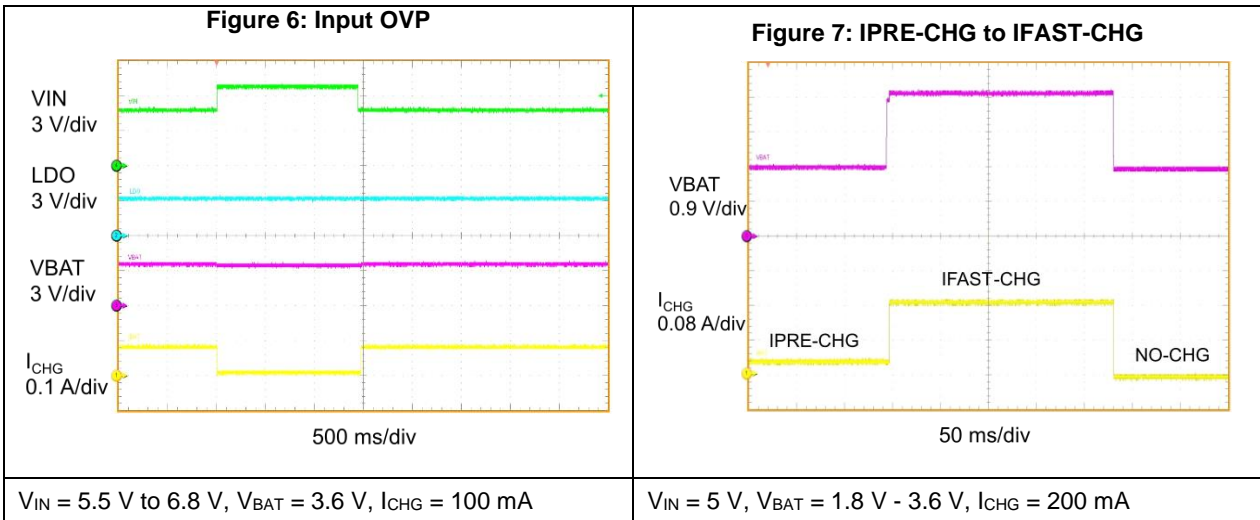
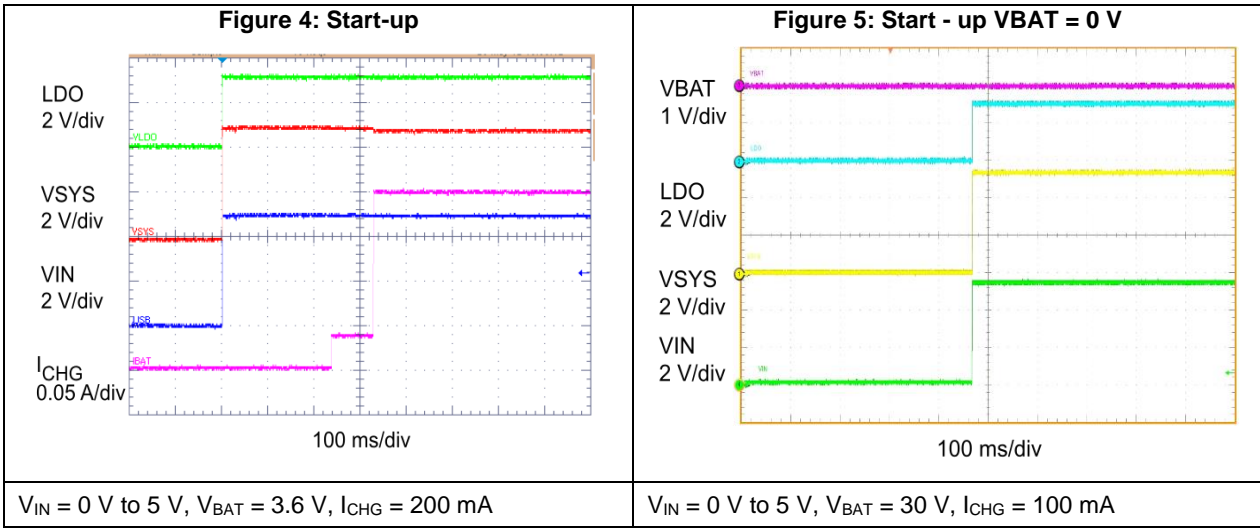

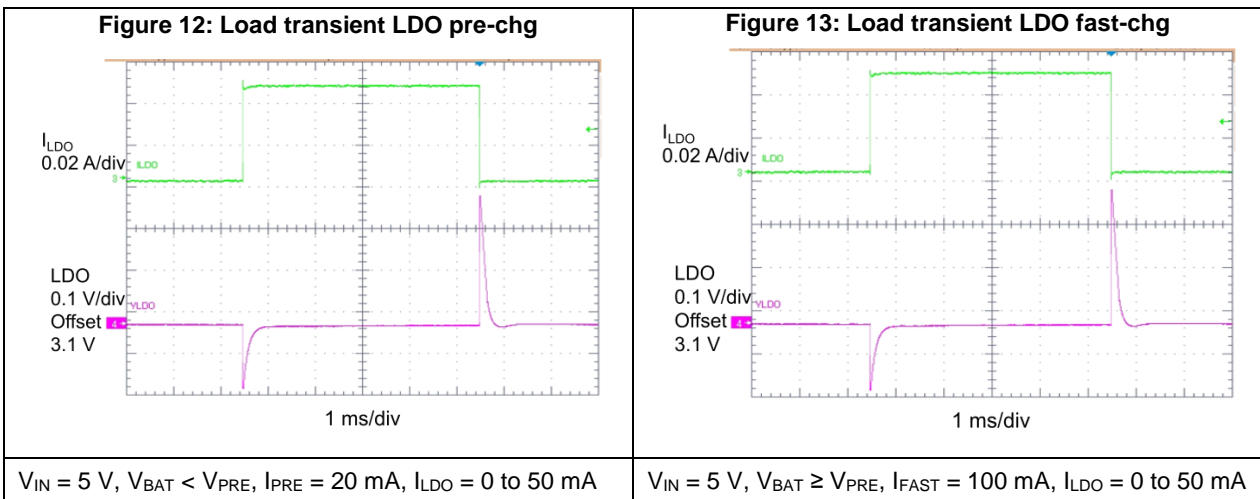
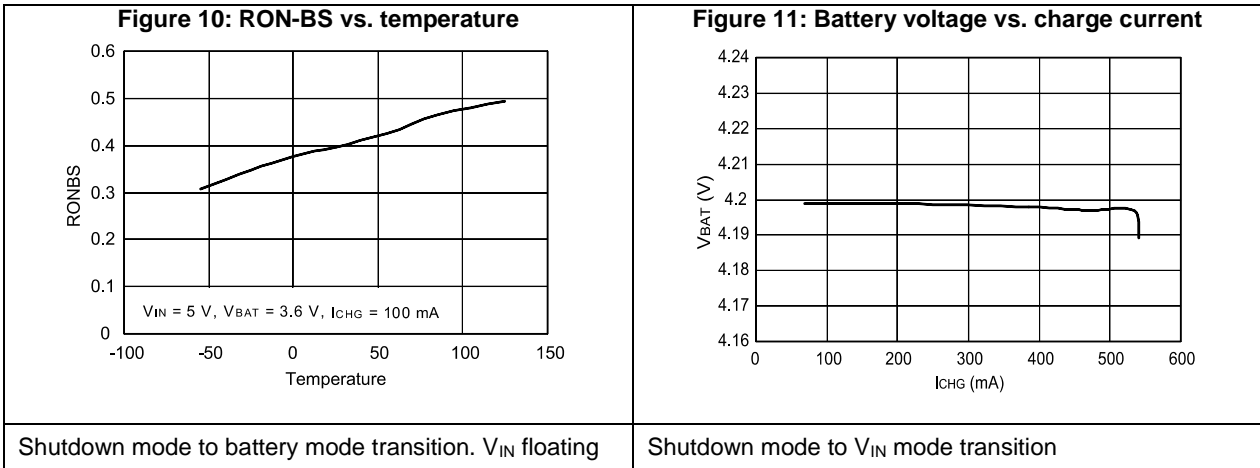
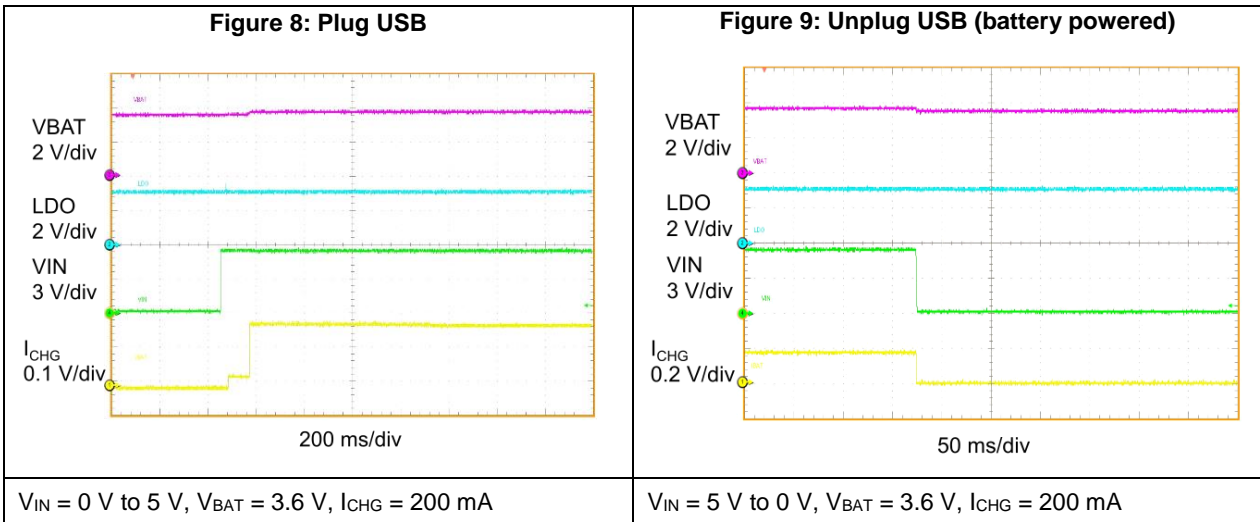

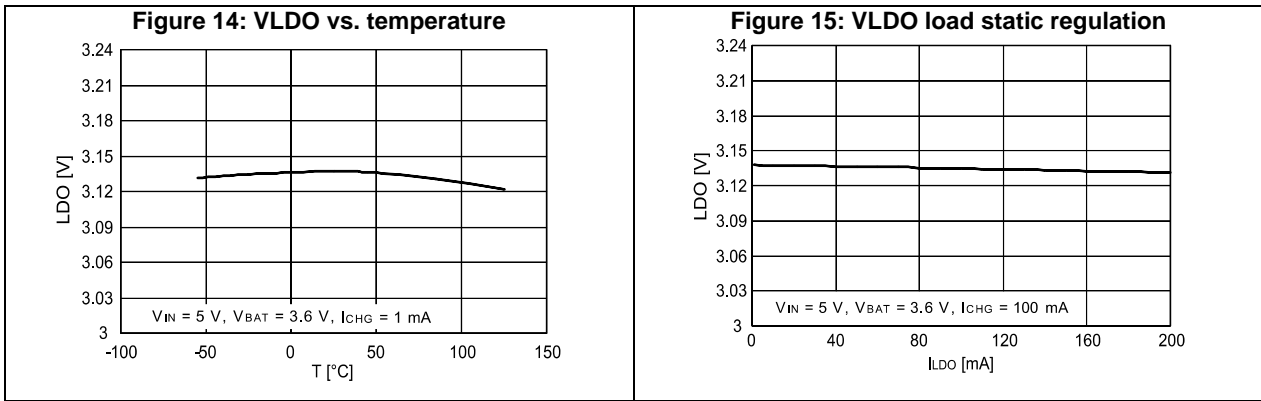

## 6.1 IN

5 V input supply voltage.

This pin supplies power to the SYS pin and the battery charger when the input voltage is higher than  $V_{UVLO}$  and lower than  $V_{INOVF}$ . Bypass this pin to GND with a 2.2  $\mu\text{F}$  ceramic capacitor.

## 6.2 SYS

LDO input voltage. This pin can be used to supply up to 100 mA to the external devices. The voltage source of this pin can be either IN or BAT depending on the operating conditions. Refer to table below for more details. Bypass this pin to GND with a 2.2  $\mu\text{F}$  ceramic capacitor.

Table 7: SYS pin voltage

$V_{IN}$	$V_{BAT}$	$V_{SYS}$	LDO
$> V_{UVLO}$ and $< V_{INOVF}$	X (do not care)	$V_{IN}^{(1)}$	ON
$< V_{UVLO}$	$< V_{ODC}^{(2)}$	Not powered	OFF
$< V_{UVLO}$	$< V_{ODC}^{(2)}$	$V_{BAT}^{(1)}$	ON
$> V_{INOVF}$	$< V_{ODC}^{(2)}$	Not powered	OFF
$> V_{INOVF}$	$< V_{ODC}^{(2)}$	$V_{BAT}^{(1)}$	ON

**Notes:**

(1)Voltage drop over internal MOSFETs is not included.

(2) $V_{ODCR}$  if shutdown mode or over-discharge protection has been previously activated.

## 6.3 LDO

LDO output voltage.

This pin outputs a 3.1 V regulated voltage and can supply up to 100 mA. Bypass this pin to GND with a 1  $\mu\text{F}$  ceramic capacitor.

## 6.4 SD

Shutdown input. A logic high level on this pin when the input voltage ( $V_{IN}$ ) is not valid makes the device enter shutdown mode. In this mode the battery drain is reduced to less than 500 nA and the SYS and LDO voltages are not present. Connecting a valid input

voltage ( $V_{UVLO} < V_{IN} < V_{INOV}$ ) restores normal operating conditions if the battery voltage is higher than  $V_{ODCR}$ . If the device is in shutdown mode and the battery voltage is lower than  $V_{ODCR}$ , when a valid input voltage is connected and then disconnected again, the STNS01 does not exit shutdown mode (see figure below). This pin has an internal 500 kΩ pull-down resistor.

Figure 16: Shutdown mode entry and exit (not to scale, deglitch times not included)

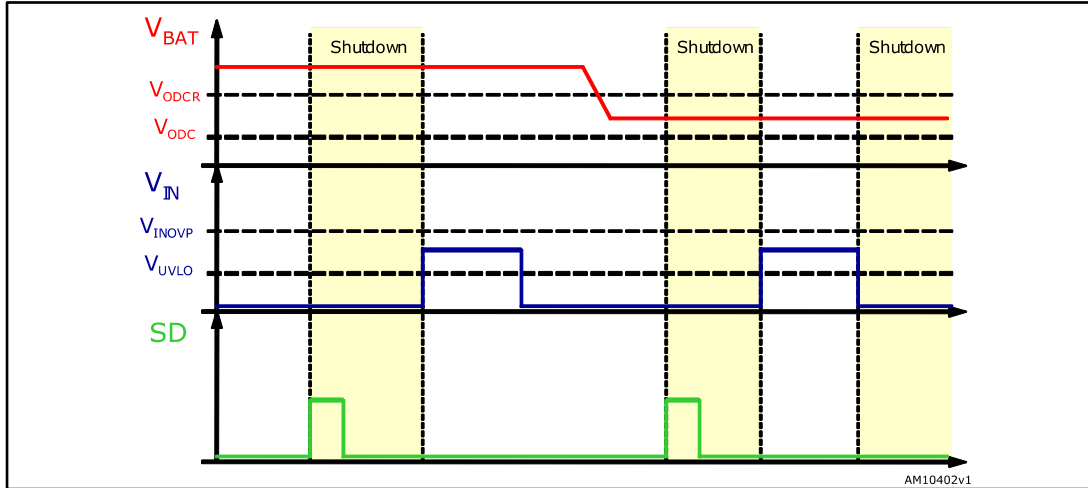

### 6.5 CHG

Active-low open-drain charging/fault flag. This pin is active when the charging process is ongoing and toggles at 1 Hz if a fault condition has been detected. Refer to table below for more details. This pin is active only when a valid voltage is connected to the IN input ( $V_{UVLO} < V_{IN} < V_{INOV}$ ).

Table 8: CHG pin state

Device state	CHG pin state
Not charging	High Z
Charging	Low
Battery temperature fault	Toggling
Overcharge fault	Toggling
Charging timeout (pre-charge, fast-charge)	Toggling
Battery voltage below $V_{PRE}$ after the fast-charge starts	Toggling

### 6.6 CEN

Charger enable pin. A logic low level on this pin disables the battery charger. A transition from high to low and then back to high restarts the charger when the charge cycle has been stopped for one of the following reasons:

- Charging timeout (pre-charge, fast-charge)
- Battery voltage below  $V_{PRE}$  after the fast-charge has already started
- End-of-charge



CEN has no effect if the charging cycle has been stopped by a battery overcharge condition.

If the charger is temporarily stopped because of the battery temperature being out of the normal range, a logic low level on the CEN pin disables the charger and resets the charging timeout timers. If CEN is then driven high again the charger is restarted only if a no-fault condition is active (including battery temperature out of range). This pin has an internal 500 kΩ pull-up resistor connected to LDO and must be left floating or tied high at power on.

Figure 17: Charge disable / enable

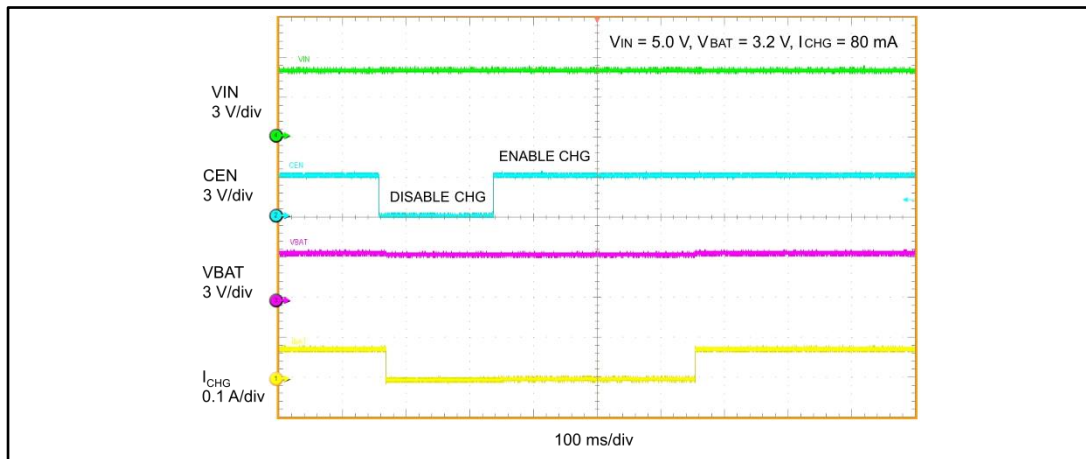

## 6.7 GND

The device ground pin.

## 6.8 NTC

Battery temperature monitoring pin. Connect the battery NTC resistor to this pin. The charging cycle is put on hold when the battery temperature is outside of the safe temperature range (0 °C to 45 °C).

## 6.9 ISET

Fast-charge current programming pin. Connect a resistor ( $R_{ISET}$ ) to ground to set the fast-charge current ( $I_{FAST}$ ) according to the following equation:

$$I_{FAST} = V_{ISET} / R_{ISET} * K$$

Where  $V_{ISET} = 1$  V and  $K = 200$ . Fast-charge currents ranging from 15 mA to 200 mA can be programmed. Pre-charge current and end-of-charge current are scaled accordingly. Charging currents higher than 200 mA can be programmed but the increased voltage drop over internal MOSFETs can limit the minimum input voltage ( $V_{IN}$ ) needed to obtain full charge.

## 6.10 BATMS

Battery voltage measurement pin. This pin is internally shorted to the BATSNS pin during normal operating conditions to monitor the battery voltage. The BATMS pin is disconnected from the battery if the LDO output voltage drops to zero (battery discharge overcurrent, battery over-discharge, shutdown mode, short-circuit on SYS or LDO).

**6.11 BATSNS**

Battery voltage sense pin. This pin is needed to ensure accuracy on the floating voltage and battery voltage protection thresholds. The BATSNS pin must be connected as close as possible to the battery positive terminal.

**6.12 BAT**

Battery positive terminal connection pin. Bypass this pin to GND with a 4.7  $\mu$ F ceramic capacitor.

## 7 Operation description

The STNS01 is a power management IC integrating a battery charger with a power path function, a battery temperature monitoring and a 3.1 V 100 mA LDO.

When a valid input voltage ( $V_{IN}$ ) is present on the IN pin, after security checks are performed, the battery charger starts charging the battery using a constant-current/constant-voltage charging algorithm. The input voltage ( $V_{IN}$ ) is considered to be valid if it is higher than  $V_{UVLO}$  and lower than  $V_{INOVLP}$ . The power path architecture allows charging the battery and supplying the system at the same time. When the input voltage is not valid, the LDO (and every external IC connected to SYS) is supplied by the battery through a low resistance path. The device also provides protection to the battery against the following fault conditions:

- Overcharge
- Over-discharge
- Charge overcurrent
- Discharge overcurrent

If a fault condition is detected when the input voltage is valid ( $V_{UVLO} < V_{IN} < V_{INOVLP}$ ), the CHG pin starts toggling, to inform the control logic that an error occurred.

The device can also be put in reduced battery drain mode (shutdown,  $I_{BAT} < 500$  nA) to maximize battery life during end-product shipping and shelf time.

### 7.1 Power-on

When the device is in shutdown mode, the pins LDO and SYS are not supplied. In order to turn the device on a valid input voltage must be connected ( $V_{IN}$ ). The CEN pin must be floating or tied high during power-on for proper operations.

### 7.2 Battery charger

The STNS01's battery charger is designed to charge single cell Li-Ion batteries up to 4.2 V using a CC-CV charging algorithm. When a valid input voltage is detected, the STNS01 starts the charge cycle and the CHG pin switches from high impedance to low level. The charging process starts if the battery voltage is higher than  $V_{BATMIN}$ . If the battery is deeply discharged (the battery voltage is lower than  $V_{PRE}$  and higher than  $V_{BATMIN}$ ) the charger enters the pre-charge phase and starts charging in constant-current mode using a low current ( $I_{PRE} = 20\% I_{FAST}$ ). If the battery voltage does not reach the  $V_{PRE}$  threshold within  $t_{PRE}$ , the charging process is stopped and a fault is signaled. When the battery voltage reaches the  $V_{PRE}$  threshold, the constant-current fast-charge phase is entered and the charging current is increased to  $I_{FAST}$ . The value of  $I_{FAST}$  can be programmed from 15 mA to 200 mA using an external resistor as described in the  $I_{SET}$  pin description. Once the fast-charge phase has started, if the battery voltage decreases again below  $V_{PRE}$ , the charging process is stopped and a fault is signaled. The constant-current fast-charge phase lasts as long as the battery voltage is lower than  $V_{FLOAT}$ . When  $V_{BAT}$  reaches  $V_{FLOAT}$ , the charging algorithm switches to constant-voltage (CV) mode. During the CV mode the battery voltage is regulated to  $V_{FLOAT}$  and the charging current starts decreasing. When the charging current reaches the  $I_{END}$  threshold ( $I_{END} = 10\% I_{FAST}$ ), the charging process is stopped and the CHG pin is put in high impedance. If the fast-charge phase is not terminated within  $t_{FAST}$ , the charging process is stopped and a fault is signaled. The battery temperature is monitored throughout the charging cycle for safety reasons. Refer to figure below for a simplified flowchart of the charging process.

Figure 18: Charging flowchart

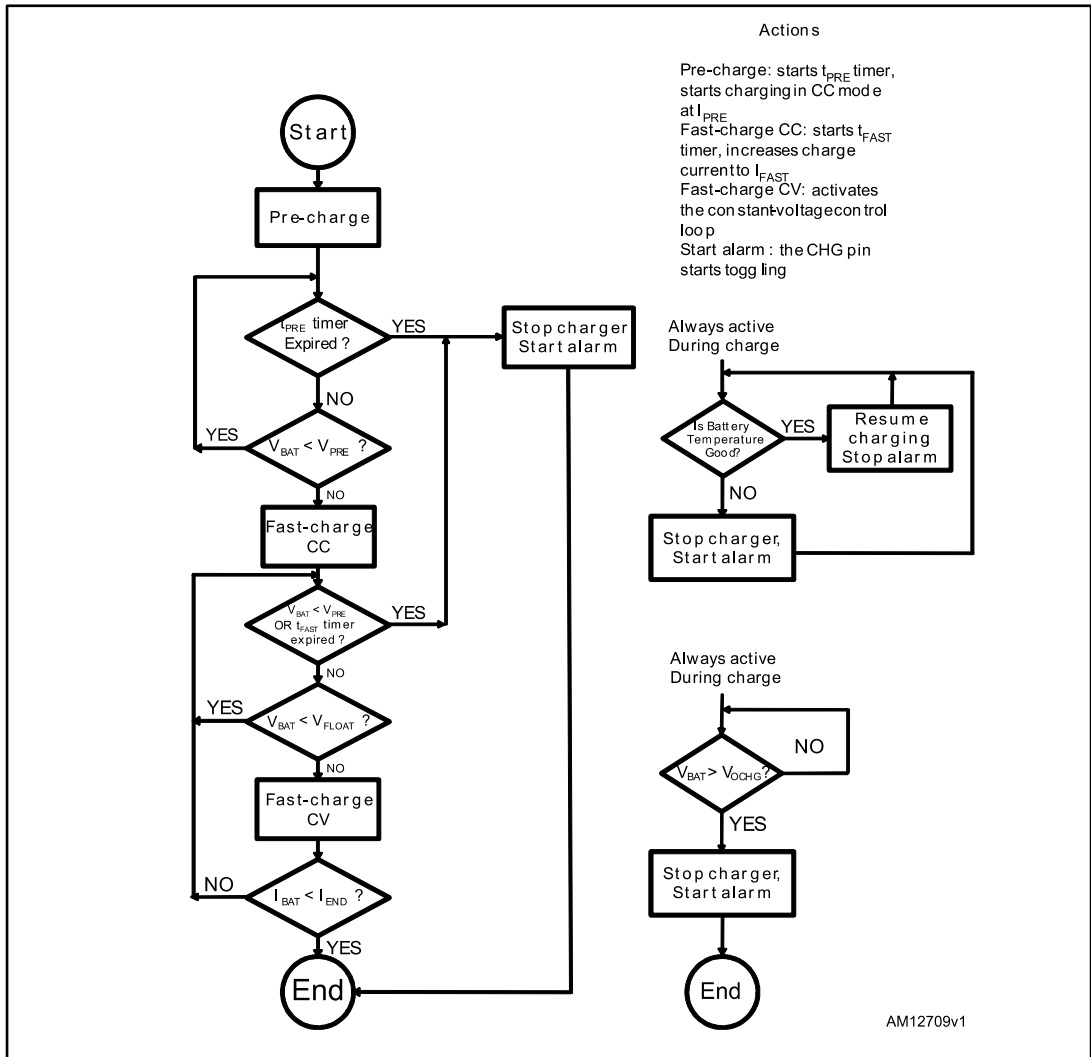

Figure 19: CC-CV charging profile (not to scale)

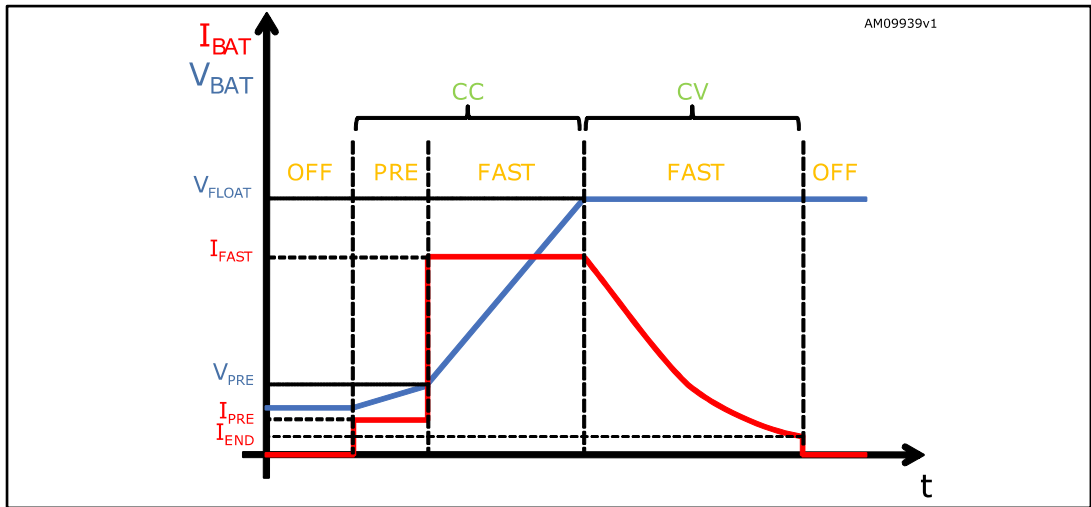
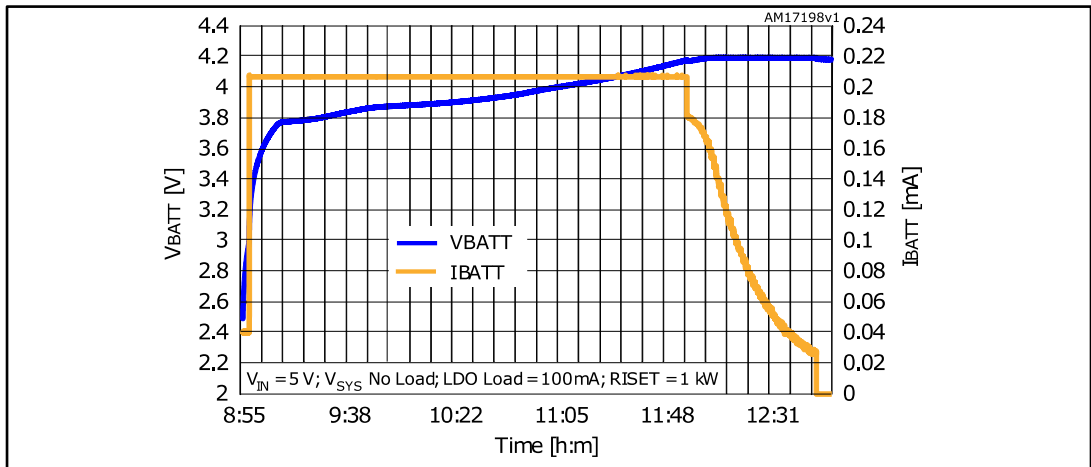

Figure 20: Charging cycle profile



### 7.3 Battery temperature monitoring

The STNS01 integrates the comparators, biasing circuit and control logic needed to monitor the battery temperature through an external NTC resistor. This feature is active only during the battery charging process in order to save power when the system is supplied from the battery. When the battery temperature goes outside the normal operating range (0 - 45 °C), the charging process is put on hold, the alarm signal is activated (the CHG pin toggles) but the charging timeout timers are kept running.

If the temperature goes back into the normal operating range before the maximum charging time has elapsed, the charging process is resumed from where it left off and the alarm signal is cleared. If the charging timeout expires while the temperature is still outside the normal operating range, the charging process is stopped but can be restarted using the CEN pin. Both temperature thresholds feature a 3 °C hysteresis. The battery temperature monitoring block is designed to work with an NTC thermistor having  $R_{25} = 10 \text{ k}\Omega$  and  $\beta = 3370$  (e.g. Mitsubishi TH05-3H103F).

### 7.4 Battery overcharge protection

The battery overcharge protection is a safety feature, active when a valid input voltage is connected, preventing the battery voltage from exceeding a  $V_{OCHG}$  value. Should an overcharge condition be detected, the current path from the input to the battery is blocked and a fault signal is activated (the CHG pin toggles at 8.2 Hz). When the battery voltage goes below  $V_{OCHG}$ , normal operations can only be restarted by disconnecting and connecting back again the input voltage ( $V_{IN}$ ).

### 7.5 Battery over-discharge protection

When there is no valid input voltage and the device is running on battery power, the battery voltage is monitored to avoid over-discharge. If the battery voltage falls below  $V_{ODC}$  for more than  $t_{ODD}$ , the device is turned off and battery drain is reduced to less than 500 nA. This condition is called the over-discharge state. When a valid input voltage is connected while in the over-discharge state, the charger and the LDO are activated. If the input voltage is then disconnected, normal operation is restored only if the battery voltage has increased above the over-discharge release threshold ( $V_{ODCR}$ ), otherwise the STNS01 remains in the battery over-discharge state.

Figure 21: Discharging cycle profile

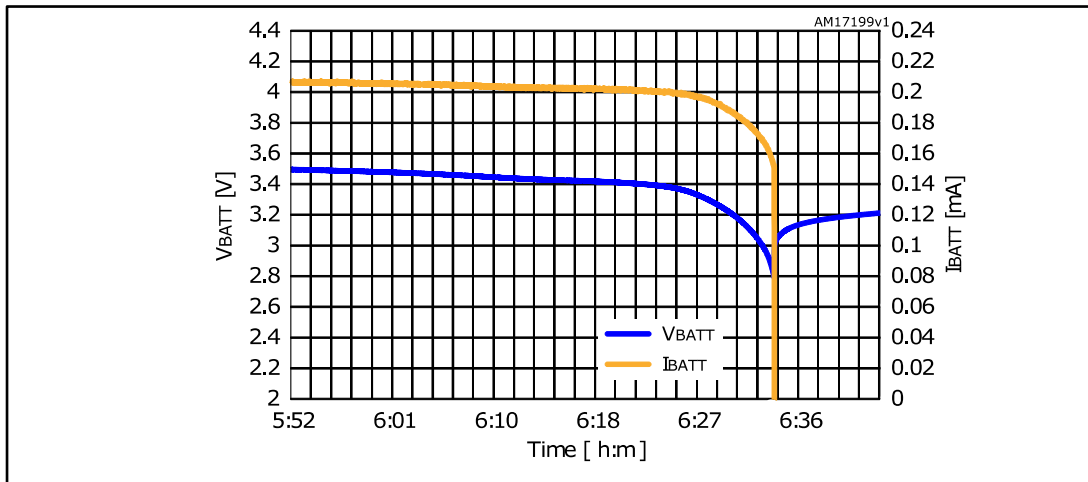

### 7.6 Battery discharge overcurrent protection

When the STNS01 is powered from the BAT pin, a discharge overcurrent protection circuit disables the device if the battery current exceeds  $I_{BATOC}$  for more than  $t_{DOD}$ . A valid input voltage ( $V_{IN}$ ) must be connected to restore normal operating conditions.

### 7.7 Input overcurrent protection

When the STNS01 is powered from the IN pin, a current limitation circuit prevents the input current from increasing up to potentially destructive values. When  $V_{SYS}$  is lower than  $V_{ILIMSC}$ , the input current is limited to  $I_{INLIMSC}$  in order to have reduced power dissipation in short-circuit conditions. As soon as  $V_{SYS}$  increases over  $V_{ILIMSC}$ , the current limitation value is increased to  $I_{INLIM}$ .

## 7.8 SYS and LDO short-circuit protection

In case of an abrupt short-circuit on SYS or LDO, the STNS01 is immediately turned off (no deglitch). This short-circuit protection intervenes when the SYS voltage drops below  $V_{SCSYS}$  or the LDO output voltage drops below  $V_{SCLDO}$ .

## 7.9 IN overvoltage protection

The STNS01 is normally powered from the battery when  $V_{IN} > V_{INOVP}$  while it is powered from the IN pin when  $V_{UVLO} < V_{IN} < V_{INOVP}$ . In the latter case, if the input voltage temporarily increases over  $V_{INOVP}$  due to a poorly regulated power supply, the STNS01 switches to battery power to protect any external circuit connected to SYS. If the input voltage ( $V_{IN}$ ) returns into the normal range, the device's supply voltage is switched back to the IN pin.

## 7.10 Shutdown mode

A high level on the shutdown digital input pin (SD) when no valid input voltage is connected makes the device enter shutdown (low power) mode. Battery drain is then reduced to less than 500 nA. The exit conditions for the shutdown mode are the same as for the over-discharge state (valid  $V_{IN}$  connected and  $V_{BAT} > V_{ODCR}$ ).

## 7.11 Thermal shutdown

The STNS01 is protected against overheating which might be generated by the combination of ambient temperature and internal heating due to power dissipation. When the die temperature exceeds  $T_{SD}$  the device is turned off. In order to restore normal operation the input voltage ( $V_{IN}$ ) must be disconnected and reconnected.

## 7.12 Reverse current protection

In order to prevent undesired battery discharge, when the input voltage ( $V_{IN}$ ) is lower than the battery voltage ( $V_{BAT}$ ), the current path from BAT to IN is blocked.

## 8 Package information

In order to meet environmental requirements, ST offers these devices in different grades of ECOPACK® packages, depending on their level of environmental compliance. ECOPACK® specifications, grade definitions and product status are available at: [www.st.com](http://www.st.com). ECOPACK® is an ST trademark.

### 8.1 DFN12L (3x3x0.75 mm) package information

Figure 22: DFN12L (3x3x0.75 mm) package outline

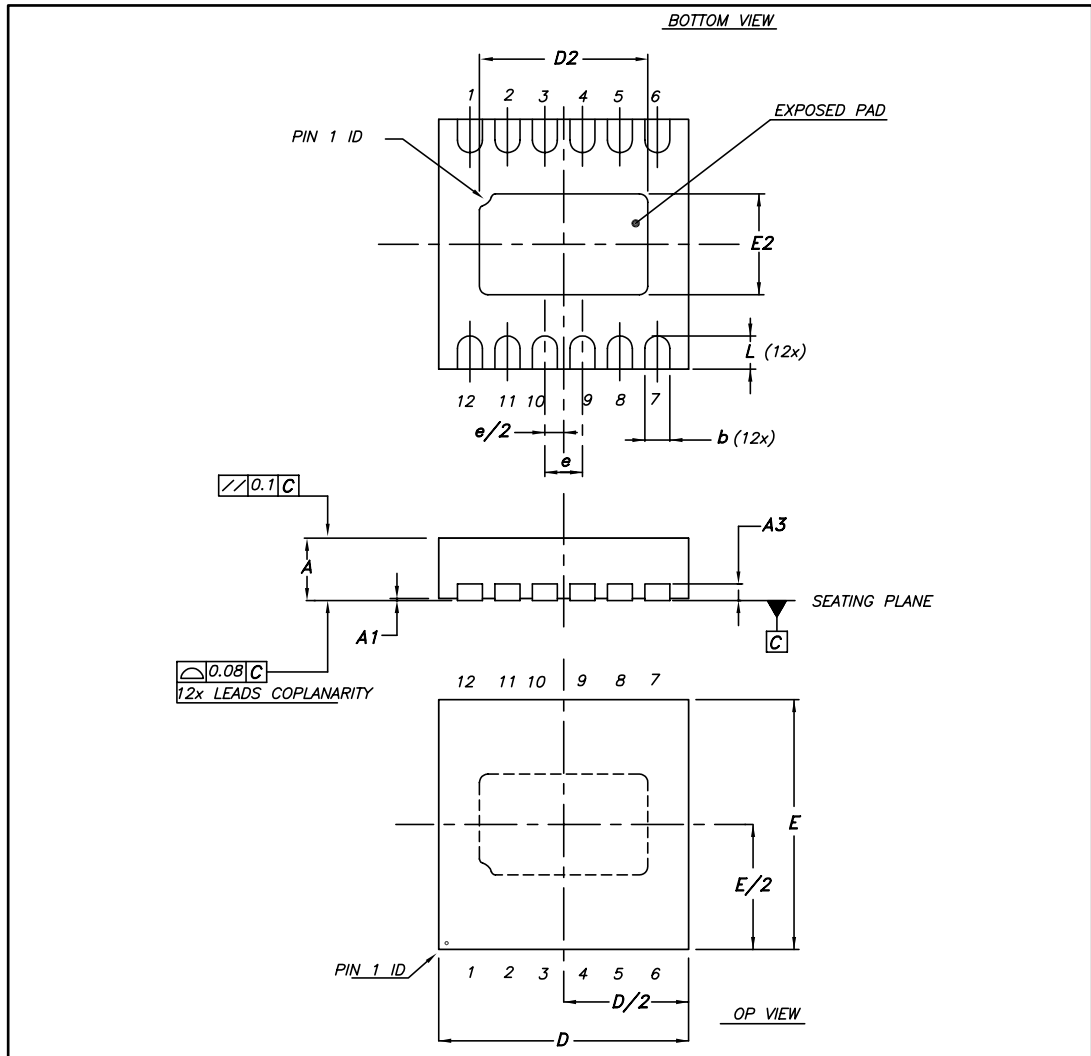





8.2 DFN12L (3x3x0.75 mm) packing information

Figure 24: Tape outline

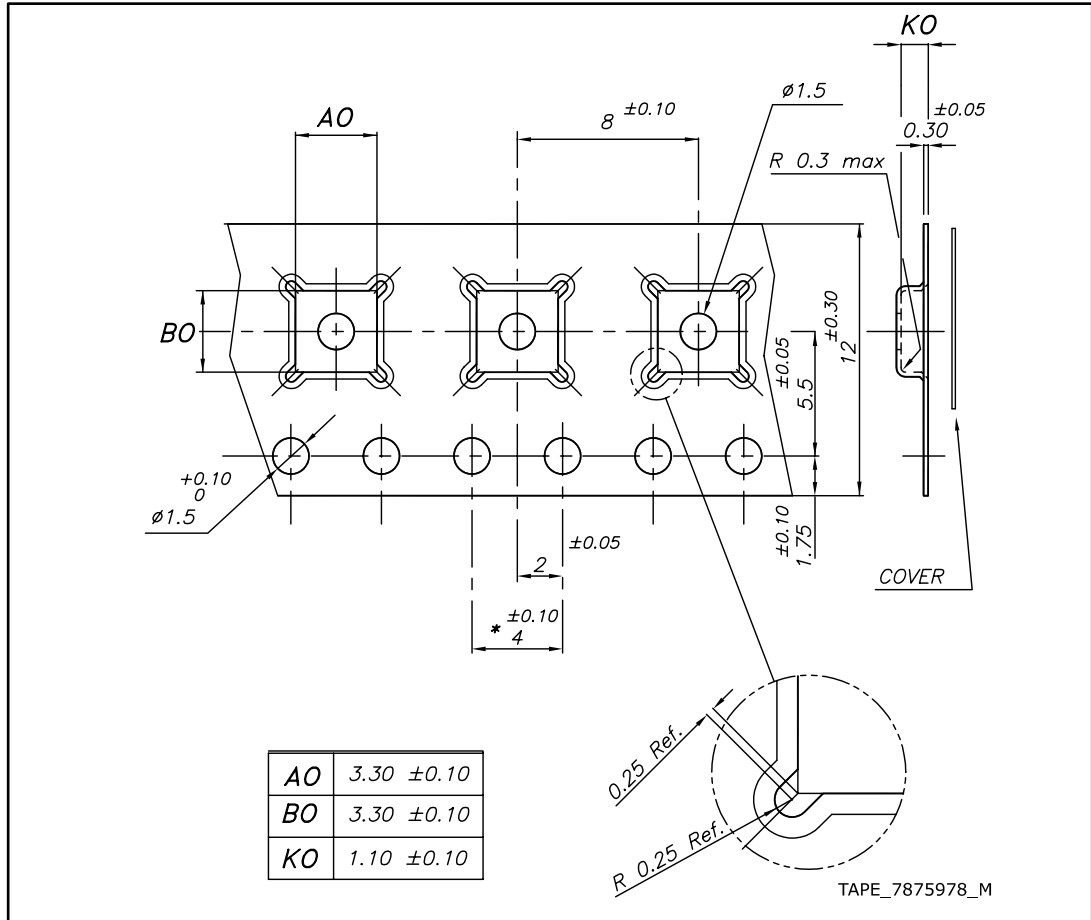
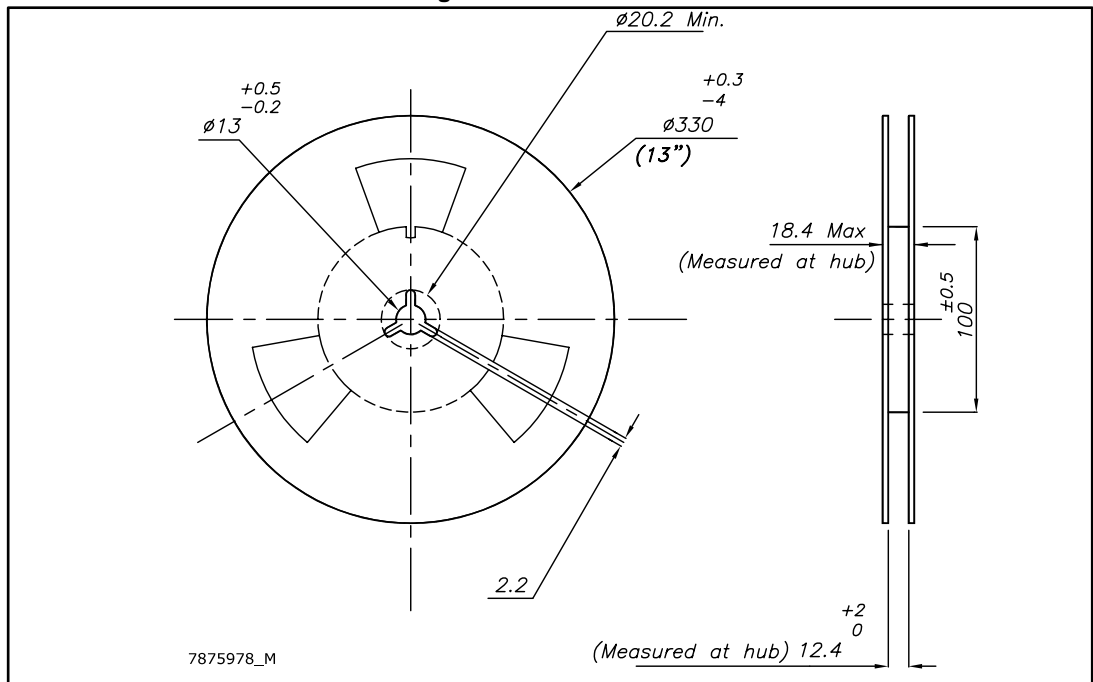

Figure 25: Reel outline



## 9 Revision history

Table 10: Document revision history

Date	Revision	Changes
17-May-2013	1	Initial release.
15-Jul-2013	2	Updated <i>Table 6: Electrical characteristics</i> .
11-May-2017	3	Updated section 5: "Electrical characteristics".
14-Dec-2017	4	Updated <i>Table 5: "Thermal data"</i> and <i>Table 6: "Electrical characteristics"</i> .

**IMPORTANT NOTICE – PLEASE READ CAREFULLY**

STMicroelectronics NV and its subsidiaries ("ST") reserve the right to make changes, corrections, enhancements, modifications, and improvements to ST products and/or to this document at any time without notice. Purchasers should obtain the latest relevant information on ST products before placing orders. ST products are sold pursuant to ST's terms and conditions of sale in place at the time of order acknowledgement.

Purchasers are solely responsible for the choice, selection, and use of ST products and ST assumes no liability for application assistance or the design of Purchasers' products.

No license, express or implied, to any intellectual property right is granted by ST herein.

Resale of ST products with provisions different from the information set forth herein shall void any warranty granted by ST for such product.

ST and the ST logo are trademarks of ST. All other product or service names are the property of their respective owners.

Information in this document supersedes and replaces information previously supplied in any prior versions of this document.

© 2017 STMicroelectronics – All rights reserved

## Данный компонент на территории Российской Федерации

### Вы можете приобрести в компании MosChip.

Для оперативного оформления запроса Вам необходимо перейти по данной ссылке:

<http://moschip.ru/get-element>

Вы можете разместить у нас заказ для любого Вашего проекта, будь то серийное производство или разработка единичного прибора.

В нашем ассортименте представлены ведущие мировые производители активных и пассивных электронных компонентов.

Нашей специализацией является поставка электронной компонентной базы двойного назначения, продукции таких производителей как XILINX, Intel (ex.ALTERA), Vicor, Microchip, Texas Instruments, Analog Devices, Mini-Circuits, Amphenol, Glenair.

Сотрудничество с глобальными дистрибьюторами электронных компонентов, предоставляет возможность заказывать и получать с международных складов практически любой перечень компонентов в оптимальные для Вас сроки.

На всех этапах разработки и производства наши партнеры могут получить квалифицированную поддержку опытных инженеров.

Система менеджмента качества компании отвечает требованиям в соответствии с ГОСТ Р ИСО 9001, ГОСТ РВ 0015-002 и ЭС РД 009

### Офис по работе с юридическими лицами:

105318, г.Москва, ул.Щербаковская д.3, офис 1107, 1118, ДЦ «Щербаковский»

Телефон: +7 495 668-12-70 (многоканальный)

Факс: +7 495 668-12-70 (доб.304)

E-mail: [info@moschip.ru](mailto:info@moschip.ru)

Skype отдела продаж:

moschip.ru

moschip.ru\_4

moschip.ru\_6

moschip.ru\_9