

FEATURES

- 0.8V to 5.5V Single-supply operation
- AC-coupled Inverting configuration supplied
- Fully Assembled and Tested
- 2mm x 2mm 2-layer demo board

COMPONENT LIST

DESIGNATION	QTY	DESCRIPTION
C1, C2, C3, C5	4	0.1 μ F \pm 10% capacitors (0805)
C4, C6	2	1 μ F \pm 10% capacitors (0805)
R2	1	665k Ω \pm 1% resistor (0805)
R7	1	500k Ω \pm 1% resistor (0805)
R5, R6, R10	3	1M Ω \pm 1% resistors (0805)
R8, R9	2	1.25M Ω \pm 1% resistors (0805)
R1, R3, R4	3	2M Ω \pm 1% resistors (0805)
U1, U2	2	TS1005 operational amplifiers
V _{DD} , V _{in} , V _{out} , GND	11	Test points

DESCRIPTION

The demo board for the TS1005 is a completely assembled and tested circuit board that can be used for evaluating the TS1005. The TS1005 is a precision CMOS operational amplifier fully specified to operate over a supply voltage range from 0.8V to 5.5V with a GBWP of 20kHz. Fully specified at 1.8V, the TS1005 is optimized for ultra-long-life battery powered applications. The TS1005 exhibits a typical input bias current of 2pA, and rail-to-rail input and output stages.

The TS1005 is fully specified over the industrial temperature range (-40°C to +85°C). The TS1005 evaluation board is offered with either a PCB-space saving 5-lead SC70 or 5-lead SOT23 packaging.

Product data sheets and additional documentation can be found on factory web site at www.touchstonesemi.com.

Ordering Information

Order Number	Description
TS1005DB	SC70 Packaging Demo Board
TS1005DB-SOT	SOT23 Packaging Demo Board

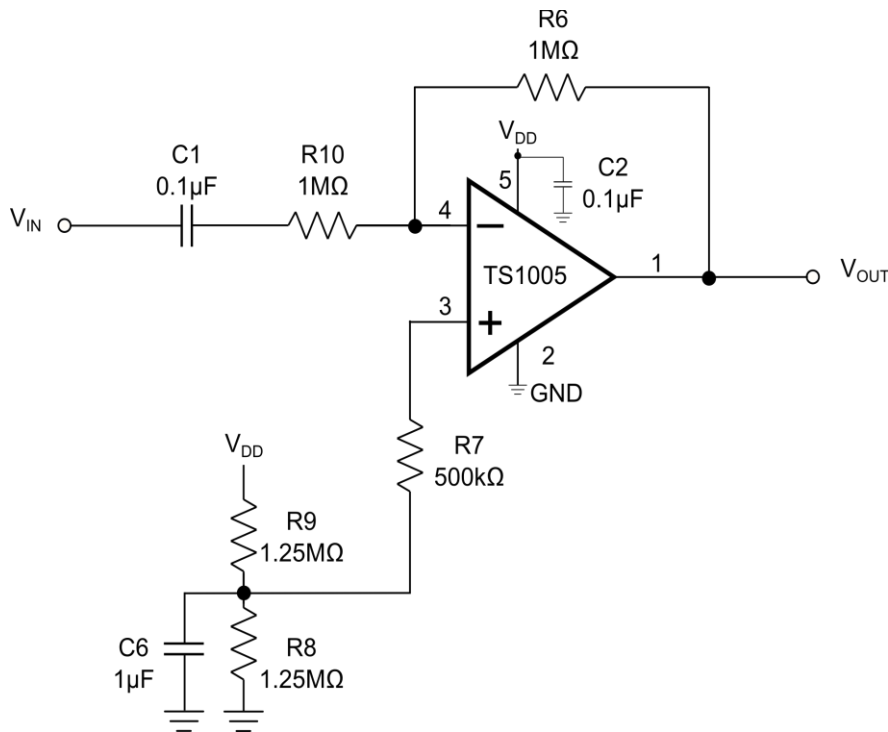

Figure 1. Inverting Configuration



Figure 2. TS1005-SOT Evaluation Board

Description

The TS1005DB evaluation board with SC70 packaging provides one configuration, namely an inverting configuration. The TS1005DB-SOT evaluation board with SOT23 packaging provides two configurations for evaluating the TS1005 operational amplifier in one single PCB board, namely a non-inverting configuration located on the left-hand side of the board and an inverting configuration located on the right-hand side of the board. In both cases, the input to each circuit is AC-coupled. The demo board provides a re-biasing scheme at one-half the power supply or $V_{DD}/2$ for the inverting configuration and at $V_{DD}/4$ for the non-inverting configuration.

The TS1005 demo board provides a dedicated power supply for the non-inverting circuit and a dedicated power supply for the inverting circuit. This provides the user the flexibility of evaluating one circuit at a time or both at the same time.

In both the non-inverting and the inverting configuration, the AC-coupling capacitor creates a high pass filter. The resulting cut-off frequency, f_c , is given as:

$$f_c = \frac{1}{2\pi RC}$$

In the non-inverting circuit, $R=R5=1M\Omega$ and $C=C5=0.1\mu F$. In the inverting case, $R=R10=1M\Omega$ and $C=C1=0.1\mu F$. In both cases, these component values generate a high-pass cut-off frequency of 1.6Hz.

Default Configurations

Non-Inverting configuration

In the non-inverting configuration, the circuit's transfer function is given by the following equation:

$$\frac{V_{OUT}}{V_{IN}} = 1 + \frac{R4}{R3}$$

With $R4=2M\Omega$ and $R3=2M\Omega$ the circuit signal gain is 2 with a circuit bandwidth of 10kHz. This results in an overall circuit bandwidth range of 1.6Hz to 10kHz.

Inverting configuration

In an inverting configuration, the circuit's transfer function is given by the following equation:

$$\frac{V_{OUT}}{V_{IN}} = - \frac{R6}{R10}$$

In this case, $R6=1M\Omega$ and $R10=1M\Omega$. This results in a signal gain of -1 with a circuit bandwidth of 10kHz and an overall circuit bandwidth range of 1.6Hz to 10kHz.

Quick Start Procedures

Required Equipment

- TS1005 demo board
- DC Power Supply, Single or Dual Output
- Function Generator
- 4-channel Oscilloscope
- Two $1M\Omega$ oscilloscope probes

Non-Inverting Configuration

In order to evaluate the TS1005 operational amplifier in the non-inverting configuration, the following steps are to be performed:

- 1) Before connecting the DC power supply to the demo board power test points, turn on the power supply and set the DC voltage to 5.5V and then turn it off.
- 2) Set the function generator frequency to 500Hz and output level with a $V_{OH} = 2.35V$ and a $V_{OL} = 2.15V$. This sets the input signal swing to $200mV_{PP}$, centered at 2.25V.
- 3) In order to monitor the input and output signal, select two channels on the oscilloscope and set the vertical voltage scale and the vertical position on each channel to 100mV/DIV and -2.25V, respectively. Set the horizontal time scale to 500 μs /DIV.
- 4) Connect the positive terminal of the DC power supply to V_{DD} and the ground terminal to GND.

- 5) Connect the signal output of the function generator to V_{in} and the ground terminal to GND.
- 6) To monitor the input, connect the signal terminal of one of the oscilloscope probes to V_{in} and the ground terminal to GND. To monitor the output, use the second probe to connect the signal terminal to V_{OUT} and the ground terminal to GND.
- 7) Turn on the power supply and check that the power supply current is approximately $4.3\mu A$.
- 8) Turn on the function generator.
- 9) Observe the input and output signal. The output signal is an amplified version of the input signal with an output swing of approximately $400mV_{PP}$, corresponding to a signal gain of two.

Inverting Configuration

In order to evaluate the TS1005 operational amplifier in the inverting configuration, the following steps are to be performed:

- 1) Before connecting the DC power supply to the demo board, turn on the power supply and set the DC voltage to 5.5V and then turn it off.
- 2) Set the function generator output frequency to 500Hz and output level with a $V_{OH} = 2.35V$ and a $V_{OL} = 2.15V$. This sets the input swing to $200mV_{PP}$, centered at 2.25V.

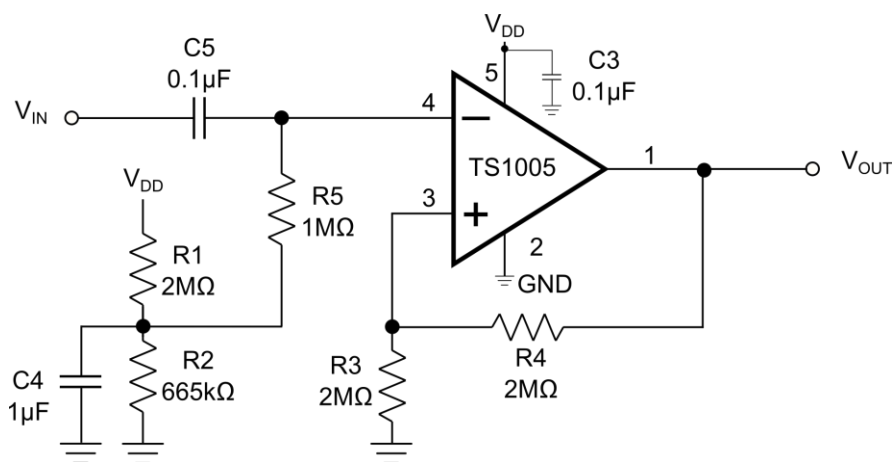

Figure 3. Non-Inverting Configuration

- 3) In order to monitor the input and output signal, select two channels on the oscilloscope and set the vertical voltage scale and the vertical position on each channel to 100mV/DIV and -2.25V, respectively. Set the horizontal time scale to 500μs/DIV.
- 4) Connect the positive terminal of the DC power supply to VDD and the ground terminal to GND.
- 5) Connect the signal output of the function generator to V_{in} and the ground terminal to GND.
- 6) To monitor the input, connect the signal terminal of one of the oscilloscope probes to V_{in} and the ground terminal to GND. To monitor the output, use the second probe to connect the signal terminal to V_{OUT} and the ground terminal to GND.
- 7) Turn on the power supply and check that the power supply current is approximately $3.8\mu A$.
- 8) Turn on the function generator.
- 9) Observe the input and output signal. The output signal is an inverted version of the input signal and the swing should be $200mV_{PP}$.



Figure 4. TS1005DB Evaluation Board

TS1005 Op Amp Demo Board

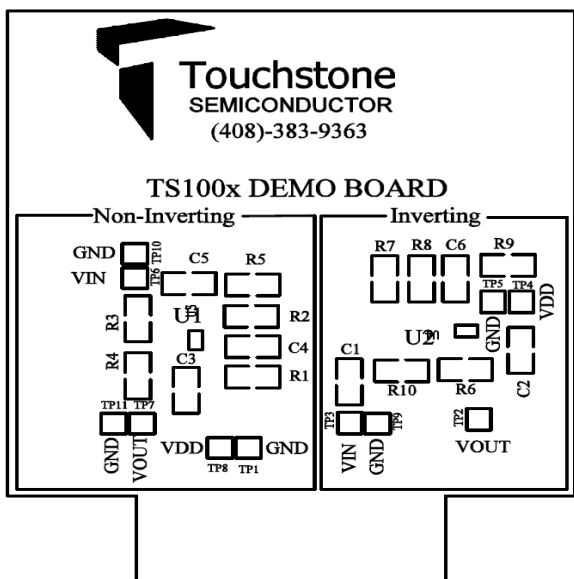

Figure 5. TS1005DB-SOT
Top Layer #1

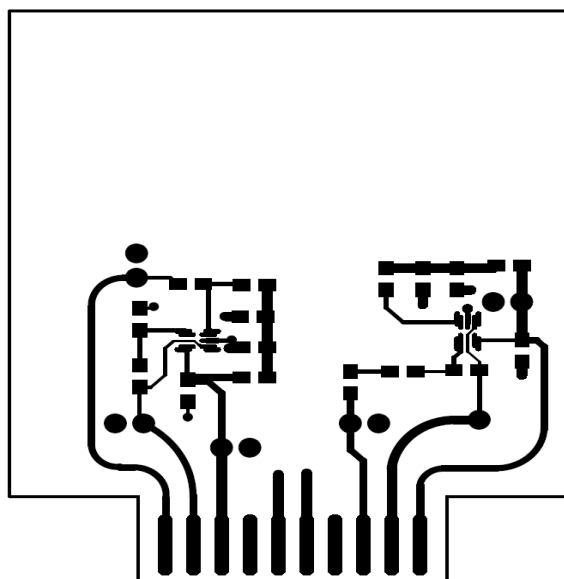

Figure 6. TS1005DB-SOT
Top Layer #2

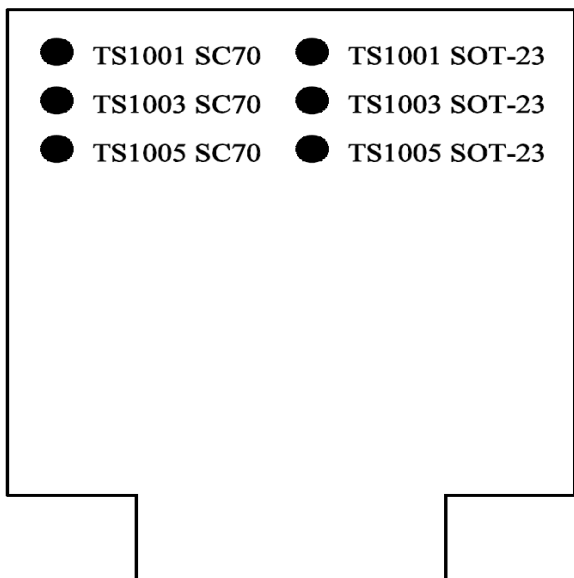

Figure 7. TS1005DB-SOT
Bottom Layer (GND) #1

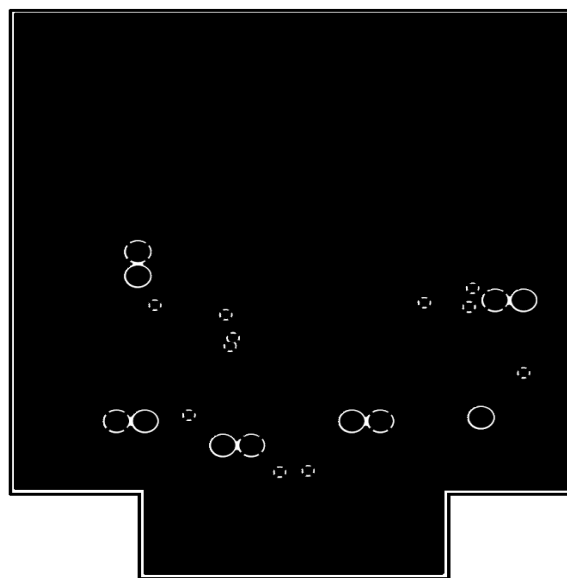

Figure 8. TS1005DB-SOT
Bottom Layer (GND) #2

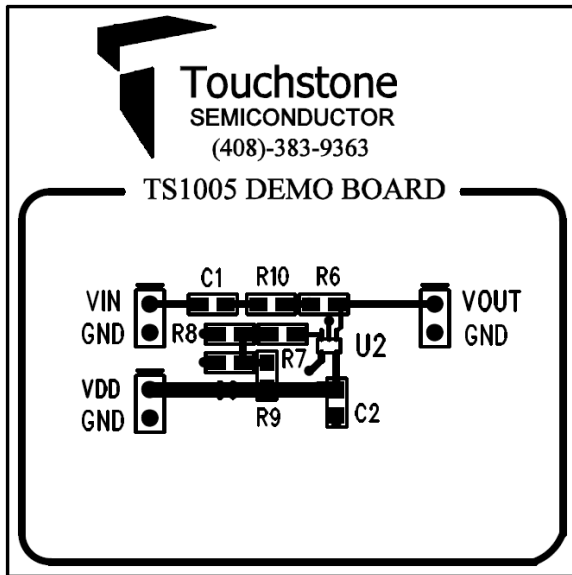

Figure 9. TS1005DB
Top Layer #1

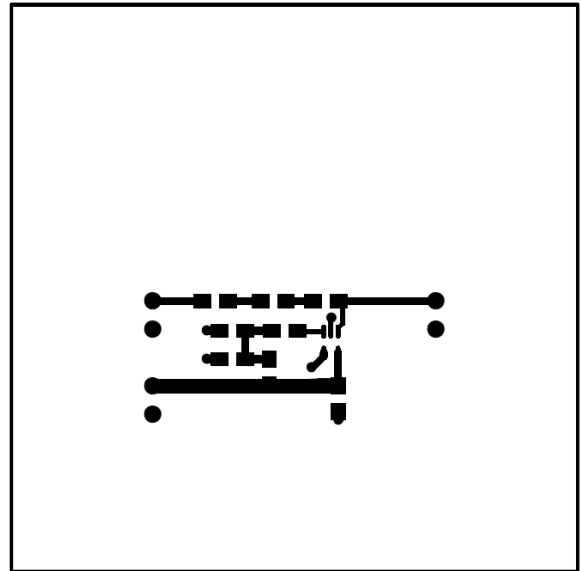

Figure 10. TS1005DB
Top Layer #1

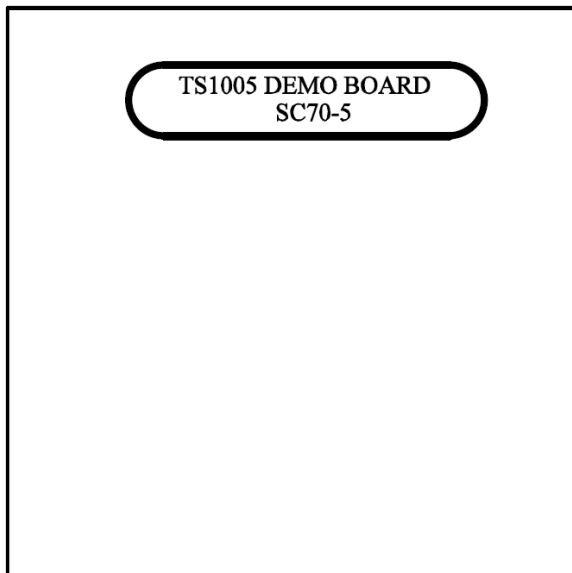

Figure 11. TS1005DB
Bottom Layer (GND) #1

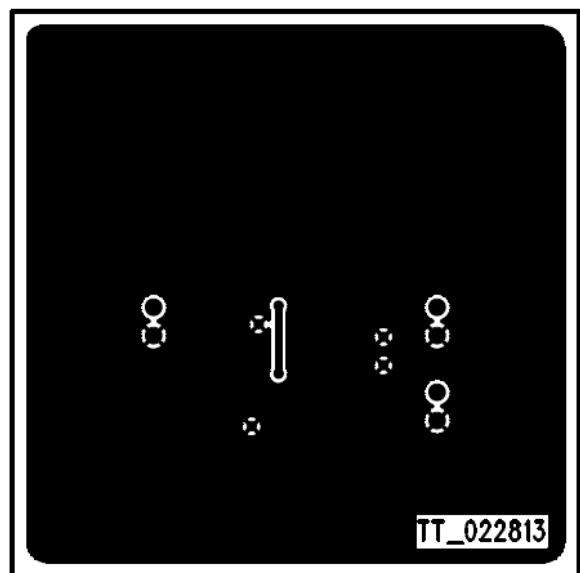

Figure 12. TS1005DB
Bottom Layer (GND) #2

Данный компонент на территории Российской Федерации

Вы можете приобрести в компании MosChip.

Для оперативного оформления запроса Вам необходимо перейти по данной ссылке:

<http://moschip.ru/get-element>

Вы можете разместить у нас заказ для любого Вашего проекта, будь то серийное производство или разработка единичного прибора.

В нашем ассортименте представлены ведущие мировые производители активных и пассивных электронных компонентов.

Нашей специализацией является поставка электронной компонентной базы двойного назначения, продукции таких производителей как XILINX, Intel (ex.ALTERA), Vicor, Microchip, Texas Instruments, Analog Devices, Mini-Circuits, Amphenol, Glenair.

Сотрудничество с глобальными дистрибьюторами электронных компонентов, предоставляет возможность заказывать и получать с международных складов практически любой перечень компонентов в оптимальные для Вас сроки.

На всех этапах разработки и производства наши партнеры могут получить квалифицированную поддержку опытных инженеров.

Система менеджмента качества компании отвечает требованиям в соответствии с ГОСТ Р ИСО 9001, ГОСТ РВ 0015-002 и ЭС РД 009

Офис по работе с юридическими лицами:

105318, г.Москва, ул.Щербаковская д.3, офис 1107, 1118, ДЦ «Щербаковский»

Телефон: +7 495 668-12-70 (многоканальный)

Факс: +7 495 668-12-70 (доб.304)

E-mail: info@moschip.ru

Skype отдела продаж:

moschip.ru

moschip.ru_4

moschip.ru_6

moschip.ru_9