

FEATURES

- 3.3V and 5V power supply options
- Up to 2.5Gbps operation
- Low noise
- Chatter-free signal detect (SD) generation
- Open collector TTL signal detect (SD) output
- TTL EN input
- Differential PECL inputs for data
- Single power supply
- Designed for use with Micrel-Synergy laser diode driver and controller
- Available in a tiny (3mm) 10-pin MSOP

APPLICATIONS

- 1.25Gbps and 2.5Gbps ethernet
- 531Mbps, 1062Mbps and 2.12Gbps Fibre Channel
- 622Mbps SONET
- Gigabit interface converter
- 2.5Gbps SDH/SONET
- 2.5Gbps proprietary links

DESCRIPTION

The SY88943V limiting post amplifier with its high gain and wide bandwidth is ideal for use as a post amplifier in fiber-optic receivers with data rates up to 2.5Gbps. Signals as small as 5mVp-p can be amplified to drive devices with PECL inputs. The SY88943V generates a chatter-free Signal Detect (SD) open collector TTL output.

The SY88943V incorporates a programmable level detect function to identify when the input signal has been lost. The SD output will change from logic "HIGH" to logic "LOW" when input signal is smaller than the swing set by SD_{LVL} . This information can be fed back to the EN input of the device to maintain stability under loss of signal condition. Using SD_{LVL} pin, the sensitivity of the level detection can be adjusted. The SD_{LVL} voltage can be set by connecting a resistor divider between V_{CC} and V_{REF} as shown in Figure 3. Figure 4, 5, 6, and 7 show the relationship between input level sensitivity and the voltage set on SD_{LVL} .

The SD output is a TTL open collector output that requires a pull-up resistor for proper operation, Figure 1.

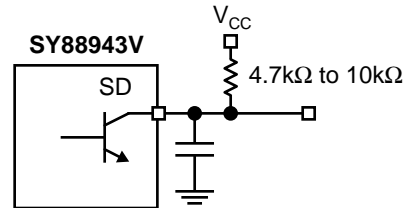
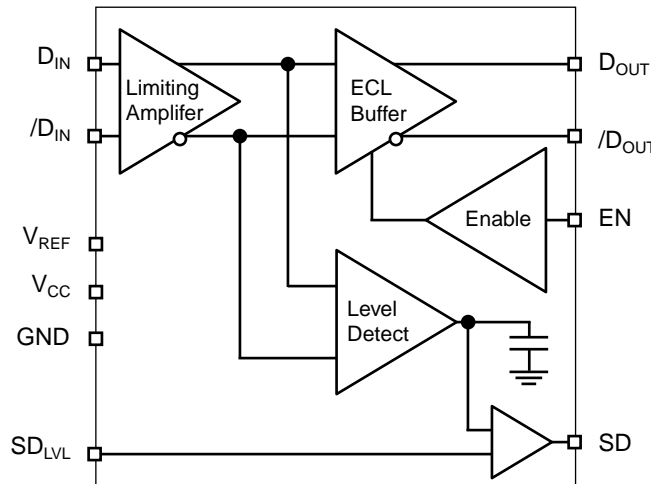
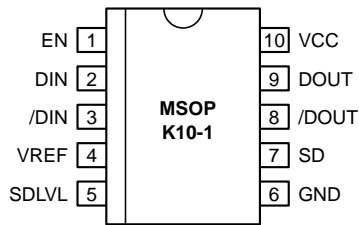

Figure 1. SD Output with Desired Rise Time

BLOCK DIAGRAM



PACKAGE/ORDERING INFORMATION



10-Pin MSOP (K10-1)

Ordering Information

Part Number	Package Type	Operating Range	Package Marking	Lead Finish
SY88943VKC	K10-1	Commercial	943V	Sn-Pb
SY88943VKCTR ⁽¹⁾	K10-1	Commercial	943V	Sn-Pb
SY88943VKG	K10-1	Commercial	943V with Pb-Free bar-line indicator	Pb-Free NiPdAu
SY88943VKGTR ⁽¹⁾	K10-1	Commercial	943V with Pb-Free bar-line indicator	Pb-Free NiPdAu

Note:

1. Tape and Reel.

PIN NAMES

Pin	Type	Function
D _{IN}	Data Input	Data Input
/D _{IN}	Data Input	Inverting Data Input
SD _{LVL}	Input	SD Level Set
EN	TTL Input	Output Enable (Active High)
SD	TTL Output (Open Collector)	Signal Detect
GND	Ground	Ground
/D _{OUT}	PECL Output	Inverting Data Output
D _{OUT}	PECL Output	Data Output
V _{CC}	Power Supply	Positive Power Supply
V _{REF}	Output	Reference Voltage Output for SD Level Set (see Fig. 3)

GENERAL DESCRIPTION

General

The SY88943V is an integrated limiting amplifier intended for high-frequency fiber-optic applications. The circuit connects to typical transimpedance amplifiers found within a fiber-optics link. The linear signal output from a transimpedance amplifier can contain significant amounts of noise, and may vary in amplitude over time. The SY88943V limiting amplifier quantizes the signal and outputs a voltage-limited waveform.

The EN pin allows the user to disable the output signal without removing the input signal.

ABSOLUTE MAXIMUM RATINGS⁽¹⁾

Symbol	Rating	Value	Unit
V _{CC}	Power Supply Voltage	0 to +7.0	V
D _{IN} , /D _{IN}	Input Voltage	0 to V _{CC}	V
D _{OUT} , /D _{OUT}	Output Voltage (with 50Ω load)	V _{CC} -2.5 to V _{CC} +0.3	V
EN	Input Voltage	0 to V _{CC}	V
SD _{LVL}	Input Voltage	0 to V _{CC}	V
V _{REF}	Output Voltage	V _{CC} -2.0 to V _{CC}	V
T _A	Operating Temperature Range	-40 to +85	°C
T _{store}	Storage Temperature Range	-55 to +125	°C

Note:

1. Permanent device damage may occur if absolute maximum ratings are exceeded. This is a stress rating only and functional operation is not implied at conditions other than those detailed in the operational sections of this data sheet. Exposure to absolute maximum rating conditions for extended periods may affect device reliability.

DC ELECTRICAL CHARACTERISTICS

$V_{CC} = +5V \pm 10\%$, $R_{LOAD} = 50\Omega$ to $V_{CC} - 2V$

Symbol	Parameter	$T_A = -40^\circ C$		$T_A = 0^\circ C$		$T_A = +25^\circ C$			$T_A = +85^\circ C$		Unit
		Min.	Max.	Min.	Max.	Min.	Typ.	Max.	Min.	Max.	
I_{CC}	Power Supply Current ⁽¹⁾	—	40	—	40	—	33	40	—	45	mA
	5V	—	40	—	40	—	28	40	—	45	
I_{IL}	EN Input LOW Current	-0.3 ⁽⁶⁾	—	-0.3 ⁽⁶⁾	—	-0.3 ⁽⁶⁾	—	—	-0.3 ⁽⁶⁾	—	mA
I_{IH}	EN Input HIGH Current	—	20 ⁽⁴⁾	—	20 ⁽⁴⁾	—	—	20 ⁽⁴⁾	—	20 ⁽⁴⁾	μA
		—	100 ⁽⁵⁾	—	100 ⁽⁵⁾	—	—	100 ⁽⁵⁾	—	100 ⁽⁵⁾	
V_{CMR}	Common Mode Range	GND +2.0	V_{CC}	GND +2.0	V_{CC}	GND +2.0	—	V_{CC}	GND +2.0	V_{CC}	V
V_{offset}	Differential Output Offset	—	± 100	—	± 100	—	± 17	± 100	—	± 100	mV
SD_{LVL}	SD_{LVL} Level	V_{REF}	V_{CC}	V_{REF}	V_{CC}	V_{REF}	—	V_{CC}	V_{REF}	V_{CC}	V
V_{OL}	SD Output Low Level ⁽²⁾	—	0.5	—	0.5	—	—	0.5	—	0.5	V
I_{OH}	SD Output Leakage ⁽³⁾	—	100	—	100	—	—	100	—	100	μA
V_{OH}	D_{OUT} and $/D_{OUT}$ HIGH Output	$V_{CC} - 1085$	$V_{CC} - 880$	$V_{CC} - 1025$	$V_{CC} - 880$	$V_{CC} - 1025$	$V_{CC} - 955$	$V_{CC} - 880$	$V_{CC} - 1025$	$V_{CC} - 880$	mV
V_{OL}	D_{OUT} and $/D_{OUT}$ LOW Output	$V_{CC} - 1830$	$V_{CC} - 1555$	$V_{CC} - 1810$	$V_{CC} - 1620$	$V_{CC} - 1810$	$V_{CC} - 1705$	$V_{CC} - 1620$	$V_{CC} - 1810$	$V_{CC} - 1620$	mV
V_{REF}	Reference Supply	$V_{CC} - 1.38$	$V_{CC} - 1.26$	$V_{CC} - 1.38$	$V_{CC} - 1.26$	$V_{CC} - 1.38$	$V_{CC} - 1.32$	$V_{CC} - 1.26$	$V_{CC} - 1.38$	$V_{CC} - 1.26$	V
I_{REF}	V_{REF} Output Current	-0.8	0.5	-0.8	0.5	-0.8	—	0.5	-0.8	0.5	mA
V_{IH}	EN Input HIGH Voltage	2.0	—	2.0	—	2.0	—	—	2.0	—	V
V_{IL}	EN Input LOW Voltage	—	0.8	—	0.8	—	—	0.8	—	0.8	V

Notes:

1. No output load
2. $I_{OL} = + 2mA$
3. $V_{OH} = 5.5V$

4. $V_{IN} = 2.7V$
5. $V_{IN} = V_{CC}$
6. $V_{IN} = 0.5V$

AC ELECTRICAL CHARACTERISTICS

$V_{CC} = +5V \pm 10\%$, $R_{LOAD} = 50\Omega$ to $V_{CC} - 2V$

Symbol	Parameter	$T_A = -40^\circ C$		$T_A = 0^\circ C$		$T_A = +25^\circ C$			$T_A = +85^\circ C$		Unit	Conditions
		Min.	Max.	Min.	Max.	Min.	Typ.	Max.	Min.	Max.		
PSRR	Power Supply ⁽¹⁾ Rejection Ratio	—	—	—	—	—	35	—	—	—	dB	Input referred, 55MHz
V_{ID}	Input Voltage Range	5	1800	5	1800	5	—	1800	5	1800	mV _{PP}	
V_{OD}	Differential Output Voltage Swing ⁽²⁾	—	—	—	—	—	700	—	—	—	mV	$V_{ID} = 15mV_{PP}$ $V_{ID} = 5mV_{PP}$
		—	—	—	—	—	300	—	—	—	mV	
t_{ONL}	SD Release Time ⁽³⁾ Minimum Input	—	0.5	—	0.5	—	0.2	0.5	—	0.5	μs	
t_{ONH}	SD Release Time ⁽⁴⁾ Maximum Input	—	0.5	—	0.5	—	0.2	0.5	—	0.5	μs	
t_{OFFL}	SD Assert Time ⁽³⁾	—	0.5	—	0.5	—	0.1	0.5	—	0.5	μs	
V_{SR}	SD Sensitivity Range	5	50	5	50	5	—	50	5	50	mV _{PP}	2 ²³ -1 pattern
HYS	SD Hysteresis	2	8	2	8	2	4.6	8	2	8	dB	2 ²³ -1 pattern
t_r, t_f	Output Rise/Fall Time	—	175	—	175	—	150	175	—	175	ps	$V_{ID} > 100mV_{PP}$ $V_{ID} < 100mV_{PP}$
		—	—	—	—	—	t_{rin}, t_{fin}	—	—	—		

Notes:

1. Input referred noise = RMS output noise/low frequency gain.
2. Input is a 622MHz square wave.

3. Input is a 200MHz square wave, $t_r < 300ps$, $8mV_{PP}$.
4. Input is a 200MHz square wave, $t_r < 300ps$, $1.8V_{PP}$.

DESIGN PROCEDURE

Output Termination

The SY88943V outputs must be terminated with a 50Ω load to $V_{CC} - 2V$ (or Thevenin equivalent).

Layout and PCB Design

Since the SY88943V is a high-frequency component, performance can be largely determined by the board layout and design. A common problem with high-gain amplifiers is the feedback from the large swing outputs to the input via the power supply.

The SY88943V ground pin should be connected to the circuit board ground. Use multiple PCB vias close to the part to connect to ground. Avoid long, inductive runs which can degrade performance.

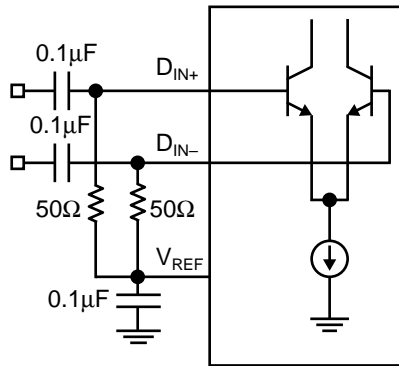

Figure 2. Differential Input Configuration

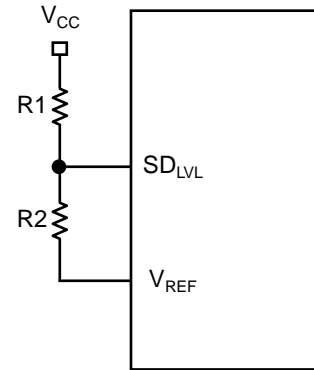

Figure 3. SD_{LVL} Circuit

Notes:

$$SD_{LVL} = V_{CC} - 1.32V + \frac{R2 \times 1.32V}{R1 + R2}$$

$$R1 + R2 \geq 2.6k\Omega$$

PERFORMANCE CURVE

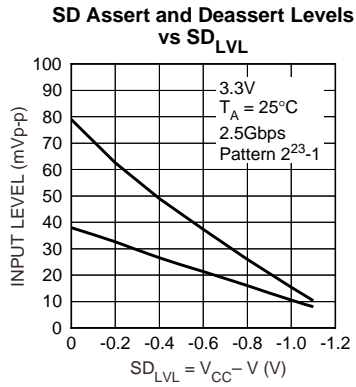

Figure 4.

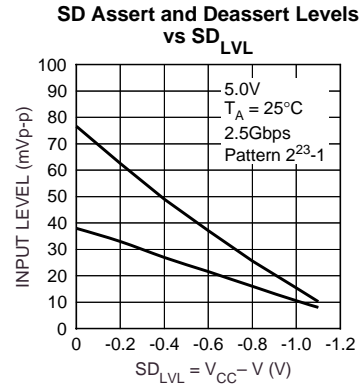

Figure 5.

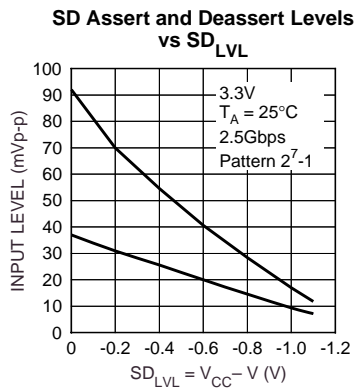

Figure 6.

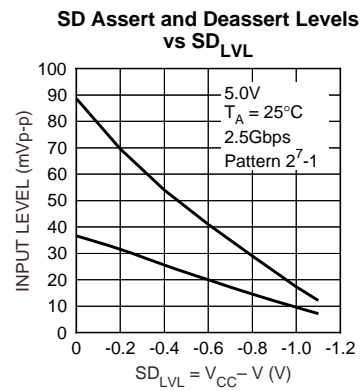
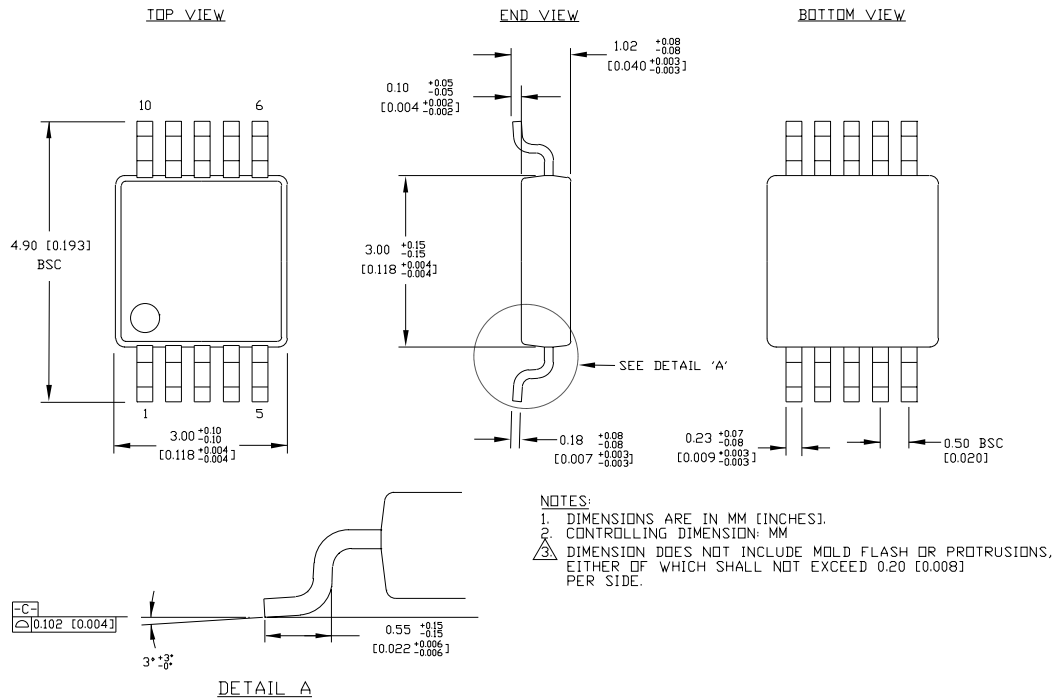

Figure 7.

10 LEAD MSOP (K10-1)



Rev. 00

MICREL, INC. 2180 FORTUNE DRIVE SAN JOSE, CA 95131 USA

TEL + 1 (408) 944-0800 FAX + 1 (408) 474-1000 WEB <http://www.micrel.com>

The information furnished by Micrel in this datasheet is believed to be accurate and reliable. However, no responsibility is assumed by Micrel for its use. Micrel reserves the right to change circuitry and specifications at any time without notification to the customer.

Micrel Products are not designed or authorized for use as components in life support appliances, devices or systems where malfunction of a product can reasonably be expected to result in personal injury. Life support devices or systems are devices or systems that (a) are intended for surgical implant into the body or (b) support or sustain life, and whose failure to perform can be reasonably expected to result in a significant injury to the user. A Purchaser's use or sale of Micrel Products for use in life support appliances, devices or systems is at Purchaser's own risk and Purchaser agrees to fully indemnify Micrel for any damages resulting from such use or sale.

© 2005 Micrel, Incorporated.

Данный компонент на территории Российской Федерации

Вы можете приобрести в компании MosChip.

Для оперативного оформления запроса Вам необходимо перейти по данной ссылке:

<http://moschip.ru/get-element>

Вы можете разместить у нас заказ для любого Вашего проекта, будь то серийное производство или разработка единичного прибора.

В нашем ассортименте представлены ведущие мировые производители активных и пассивных электронных компонентов.

Нашей специализацией является поставка электронной компонентной базы двойного назначения, продукции таких производителей как XILINX, Intel (ex.ALTERA), Vicor, Microchip, Texas Instruments, Analog Devices, Mini-Circuits, Amphenol, Glenair.

Сотрудничество с глобальными дистрибьюторами электронных компонентов, предоставляет возможность заказывать и получать с международных складов практически любой перечень компонентов в оптимальные для Вас сроки.

На всех этапах разработки и производства наши партнеры могут получить квалифицированную поддержку опытных инженеров.

Система менеджмента качества компании отвечает требованиям в соответствии с ГОСТ Р ИСО 9001, ГОСТ РВ 0015-002 и ЭС РД 009

Офис по работе с юридическими лицами:

105318, г.Москва, ул.Щербаковская д.3, офис 1107, 1118, ДЦ «Щербаковский»

Телефон: +7 495 668-12-70 (многоканальный)

Факс: +7 495 668-12-70 (доб.304)

E-mail: info@moschip.ru

Skype отдела продаж:

moschip.ru

moschip.ru_4

moschip.ru_6

moschip.ru_9