

Phantom Fin Multiband Roof Mount Antenna FHQ69273CD



Patent Pending

PHANTOM FIN 4G/LTE, GPS, UHF & WLAN ROOF MOUNT ANTENNA

The Laird Phantom Fin multiband antenna provides an excellent solution for the public safety, transportation and after market fleet applications. The Phantom Fin requires only (1) one single hole mount/fixing which reduces vehicle damage, cost of installation and visual impact. The Phantom Fin design provides multiple antenna functions while remaining discrete. The Phantom Fin multiband antenna integrates 4G/LTE, GPS, UHF and WLAN frequency operation into one aerodynamic housing.

FEATURES

- One (1) single hole mount/fixing which reduces vehicle damage and cost of installation.
- Attractive, IP67 rated aerodynamic housing excellent for overt and/or discrete installations.
- Multiband 4G/LTE, GPS, UHF, and WLAN frequency operation.

MARKETS

- Public Safety
- Transportation
- Aftermarket Fleet
- Land Mobile Radio

SPECIFICATIONS

PARAMETER	PERFORMANCE				
Antenna Model / No. of Ports:	FHQ69273CD 4 ports				
Port ID	4G/LTE Port		WiFi Port		UHF Port
Frequency Bands, MHz	698-960 MHz	1710-2700 MHz	2400-2500 MHz	4900-5875 MHz	380-430 MHz
Peak Gain, Typical dBi	3.4 dBi	5.5 dBi	6.6 dBi	6.2 dBi	2.0 dBi
Peak Gain, Maximum dBi	4.0 dBi	6.4 dBi	7.1 dBi	7.8 dBi	2.6 dBi
Max Gain ± 30° Above Horizon, dBi	N/A	N/A	N/A	4.1 dBi	N/A
VSWR*, Typical	< 1.9:1	< 1.5:1	< 1.3:1	< 1.3:1	< 1.6:1
VSWR*, Max	< 2.0:1	< 2.0:1	< 2.0:1	< 2.0:1	< 2.0:1
Port-to-Port Isolation, Maximum (Typical)	UHF-LTE > 15 dB (18 dB)	UHF-WiFi > 20 dB (31 dB)	LTE-WiFi > 20 dB (23 dB)		
Nominal Impedance	50 Ohms				
Polarization	Vertical Linear				
Azimuth Beam Width	Omnidirectional				
Input Power, Max	10 watt (ambient temp. of 25°C / 77°F)				
Operating Temperature	- 30°C to + 70°C (- 22°F to + 158°F)				
Storage Temperature	- 40°C to + 85°C (- 40°F to + 185°F)				
Dimensions HxLxW mm (inches)	98 x 70 x 160 (3.9"x 2.7" x 6.30")				
Weight Kg (lbs.)	Approximately 0.52 Kg (1.15 lbs.)				
Cable	LMR-100 (5.18 m / 17 ft.)				
Radome Material	PC/ASA (Black)				
Baseplate Material	Aluminum				
Material Compliance	RoHS Compliant				
IP Dust & Water Ingress Rating	IP67				

Americas: +1.847.839.6925
IAS-AmericasEastSales@lairdtech.com

Europe: +44.(0).1628.858941
IAS-EUSales@lairdtech.com

Asia: IAS-AsiaSales@lairdtech.com

www.lairdtech.com

Laird warrants to the original end user customer of its products that its products are free from defects in material and workmanship. Subject to conditions and limitations Laird will, at its option, either repair or replace any part of its products that prove defective by reason of improper workmanship or materials. This limited warranty is in force for the useful lifetime of the original end product into which the Laird product is installed. Useful lifetime of the original end product may vary but is not to exceed five (5) years from the original date of the end product purchase.



SPECIFICATIONS - GPS

PARAMETER	PERFORMANCE		
Frequency Band	1575.42 MHz (GPS L1)		
Band Width	6 MHz (Typical)		
Amplifier Gain	27 dB ± 3 dBc		
Nominal Impedance	50 Ohm		
Output VSWR	< 1.5:1		
DC Voltage	2.7 -12 Vdc		
DC Current	20 mA (Nominal); <30 mA (-40°C to +85°C)		
Out-of-Band Signal Rejection	> 40 dB rejection @ ± 50 MHz from center frequency		
Intermodulation @ CW Mode (-40°C to +85°C)	Int1	Int2	IM3
	- 10 (1842.8 MHz)	- 10 (2110 MHz)	<- 100 (1575.6 MHz)
	- 10 (829.58 MHz)	- 10 (2405 MHz)	<- 100 (1575.42 MHz)
	- 10 (755.42 MHz)	- 10 (820 MHz)	<- 100 (1575.42 MHz)
Input 1 dB Compression @ 750 MHz, 2000 MHz & 3500 MHz	> 10dBm (-40°C to +85°C)		
Cable - Exposed Length	RG174-518.2 cm (17 ft.)		

CONFIGURATION

PART NUMBER	CONNECTOR:	GPS	LTE	WiFi	UHF
FHQ69273CD-518VC3		SMA-male	SMA-male	SMA-male	PL259
FHQ69273CD-518VC4		SMA-male	SMA-male	SMA-male	FME Plug
FHQ69273CD-518VC5		SMA-male	SMA-male	RPSMA-male	PL259
FHQ69273CD-518VC6		SMA-male	SMA-male	RPSMA-male	FME Plug

ANTENNA DRAWING

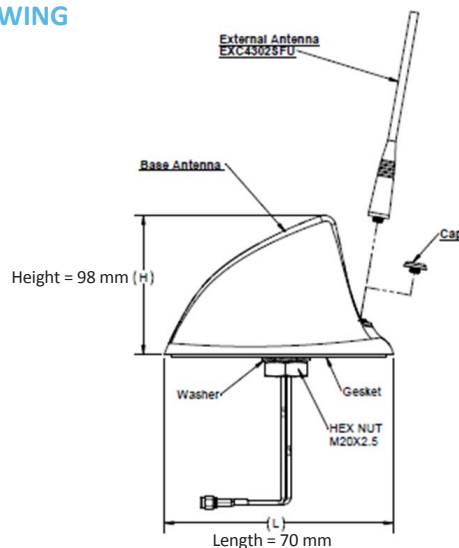

ANT-DS-PhantomFin_FHQ69273CD_0816

Any information furnished by Laird Inc. and its agents is believed to be accurate and reliable. All specifications are subject to change without notice. Responsibility for the use and application of Laird materials rests with the end user, since Laird and its agents cannot be aware of all potential uses. Laird makes no warranties as to the fitness, merchantability or suitability of any Laird materials or products for any specific or general uses. Laird shall not be liable for incidental or consequential damages of any kind. All Laird products are sold pursuant to the Laird Terms and Conditions of sale in effect from time to time, a copy of which will be furnished upon request. © Copyright 2016 Laird Inc. All Rights Reserved. Laird, Laird Technologies, the Laird Logo, and other marks are trade marks or registered trade marks of Laird Inc. or an affiliate company thereof. Other product or service names may be the property of third parties. Nothing herein provides a license under any Laird or any third party intellectual property rights.

Данный компонент на территории Российской Федерации

Вы можете приобрести в компании MosChip.

Для оперативного оформления запроса Вам необходимо перейти по данной ссылке:

<http://moschip.ru/get-element>

Вы можете разместить у нас заказ для любого Вашего проекта, будь то серийное производство или разработка единичного прибора.

В нашем ассортименте представлены ведущие мировые производители активных и пассивных электронных компонентов.

Нашей специализацией является поставка электронной компонентной базы двойного назначения, продукции таких производителей как XILINX, Intel (ex.ALTERA), Vicor, Microchip, Texas Instruments, Analog Devices, Mini-Circuits, Amphenol, Glenair.

Сотрудничество с глобальными дистрибьюторами электронных компонентов, предоставляет возможность заказывать и получать с международных складов практически любой перечень компонентов в оптимальные для Вас сроки.

На всех этапах разработки и производства наши партнеры могут получить квалифицированную поддержку опытных инженеров.

Система менеджмента качества компании отвечает требованиям в соответствии с ГОСТ Р ИСО 9001, ГОСТ РВ 0015-002 и ЭС РД 009

Офис по работе с юридическими лицами:

105318, г.Москва, ул.Щербаковская д.3, офис 1107, 1118, ДЦ «Щербаковский»

Телефон: +7 495 668-12-70 (многоканальный)

Факс: +7 495 668-12-70 (доб.304)

E-mail: info@moschip.ru

Skype отдела продаж:

moschip.ru

moschip.ru_4

moschip.ru_6

moschip.ru_9