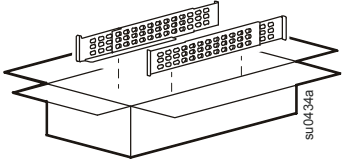
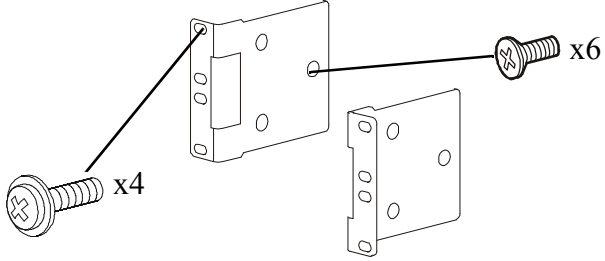
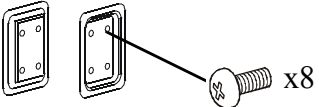

Installation Guide Smart-UPS™ On-Line SRTRK4 Tower to Rack-Mount Conversion

Package Contents

Inspect the contents upon receipt. Notify the carrier and dealer if the unit is damaged.

<p>One Rail Kit with instructions and hardware for installing rails in a rack.</p> 	<ul style="list-style-type: none">• 1 pair of rack-mount brackets• 6 flat head screws to secure rack-mount brackets to the UPS• 4 ornamental screws to secure rack-mount brackets to the rails 
<ul style="list-style-type: none">• 1 pair of rail cleats• 8 screws to secure cleats to the UPS 	

SRTRK4 is compatible with all the variants of the following models:

- SRT1000
- SRT1500
- SRT2200
- SRT3000

Note: UPS and External Battery Pack (XLBP) models may differ in appearance from those depicted in these graphics. The installation process is identical for all models.

Tower to Rack-Mount Conversion of UPS

⚠ CAUTION

DAMAGE TO EQUIPMENT OR PERSONNEL

- The equipment is heavy. Each APCRBC152 battery module weighs 16.4 kg (36.2 lbs) and each APCRBC141 battery module weighs 12.5 kg (27.6 lb). Each APCRBC155 battery module weighs 11 kg (24.25 lb).
- Always practice safe lifting techniques adequate for the weight of the equipment.
- Remove the battery modules before installing the UPS.
- Use the battery module handle to carefully slide the battery module in or out of the unit.
- Do not use the battery module handle to lift or carry the battery module.
- Place the UPS on a table to remove the stabilizer brackets.
- Always install the UPS at the bottom of the rack.
- Always install the XLBP below the UPS in the rack.

Failure to follow these instructions can result in equipment damage and minor or moderate injury.

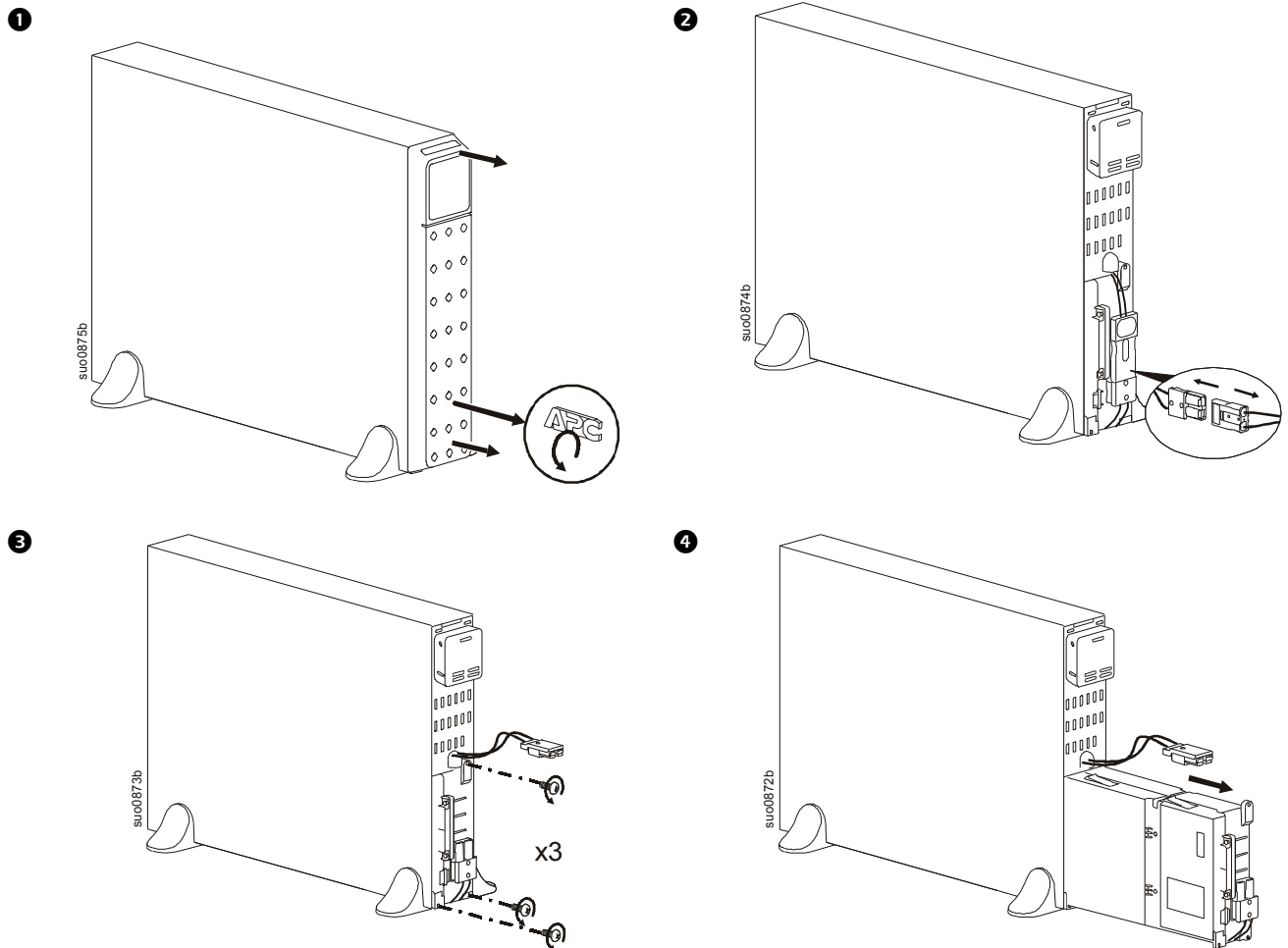

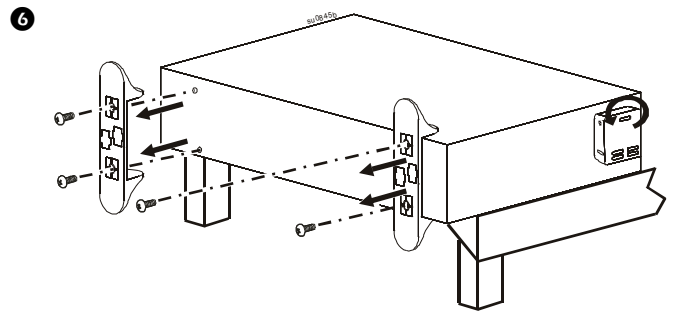
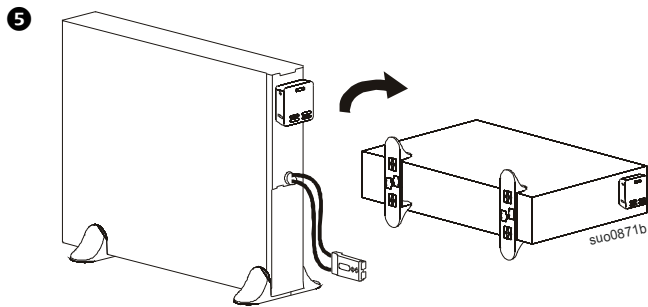

Install UPS in Rack

Refer to the Rail Kit Installation Guide for instructions on rail installation.

⚠ CAUTION

DAMAGE TO EQUIPMENT OR PERSONNEL

- The equipment is heavy. Always practice safe lifting techniques adequate for the weight of the equipment.
- Always use the recommended number of screws to secure brackets to the UPS.
- Always use the recommended number of screws to secure the UPS to the rack.
- Always install the UPS at the bottom of the rack.
- Always install the XLBP below the UPS in the rack.

Failure to follow these instructions can result in equipment damage and minor or moderate injury

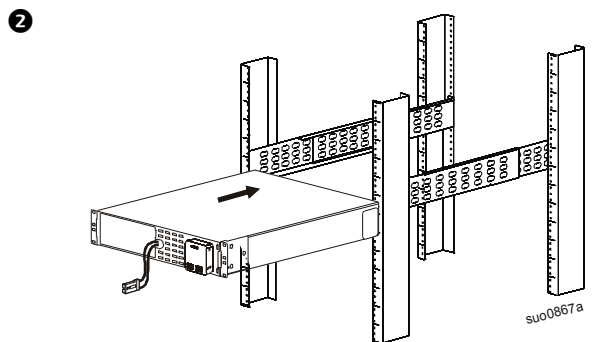
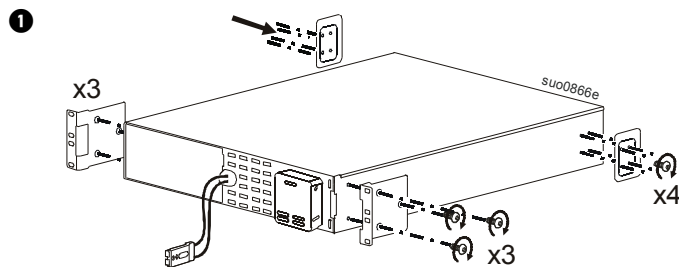

3

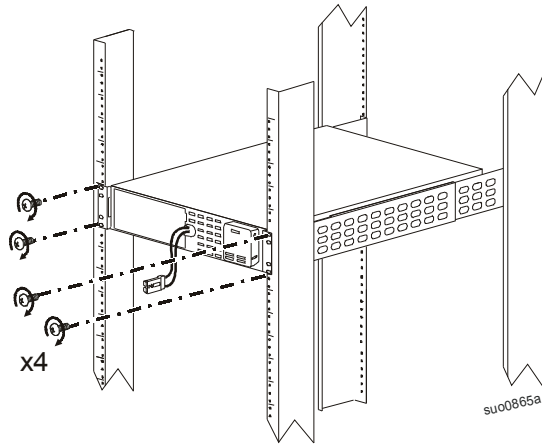

4

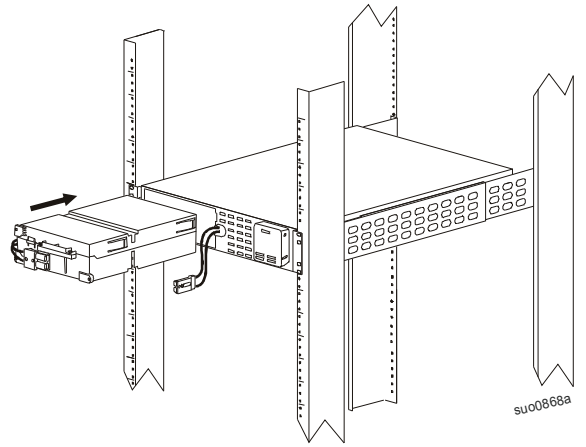

5

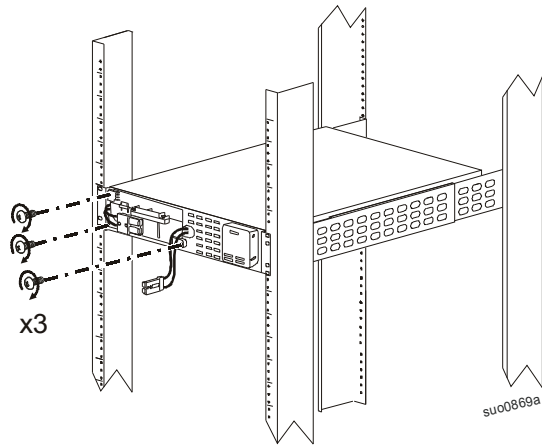

6

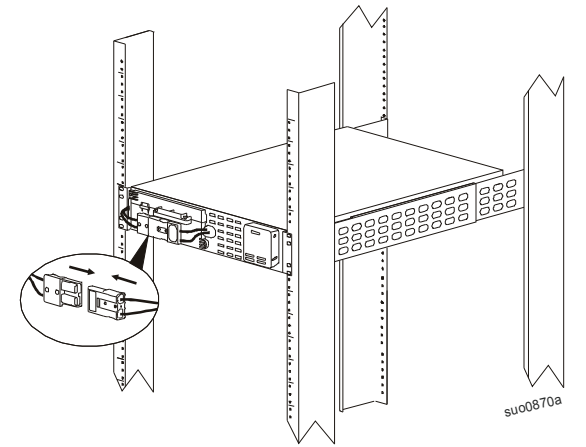

7

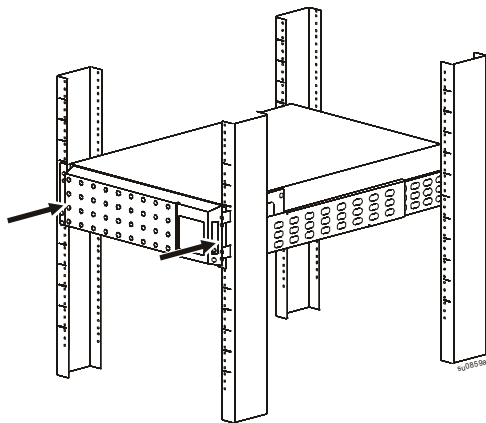

Tower to Rack-Mount Conversion of UPS with one External Battery Pack

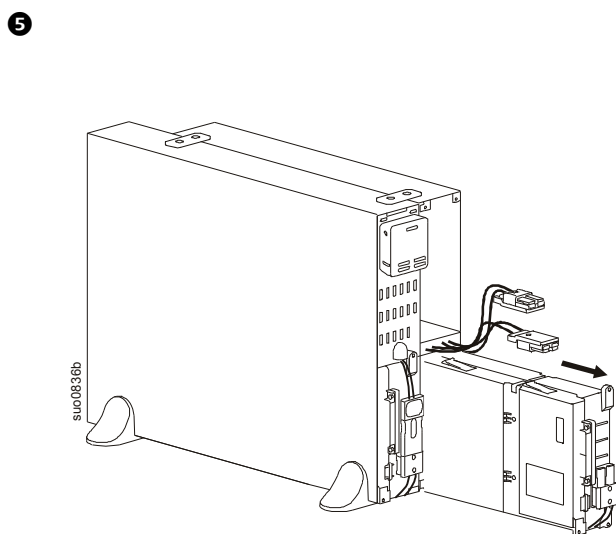
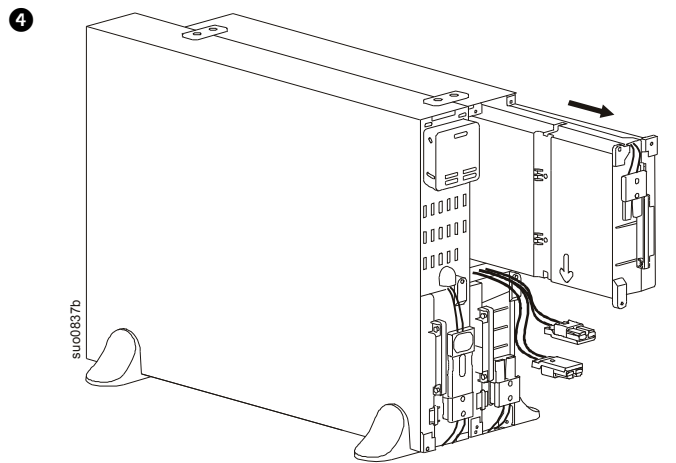
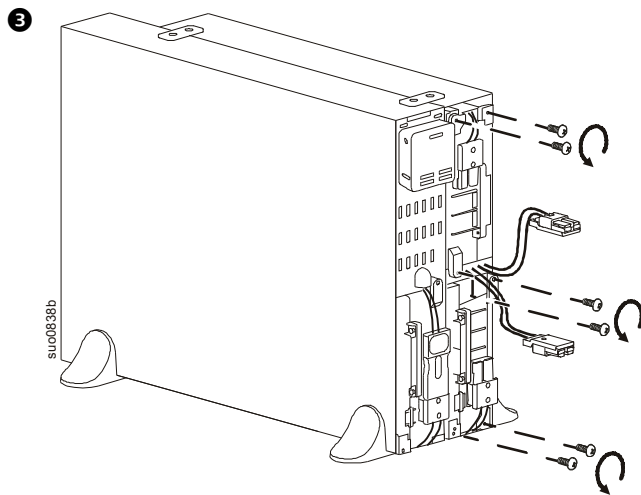
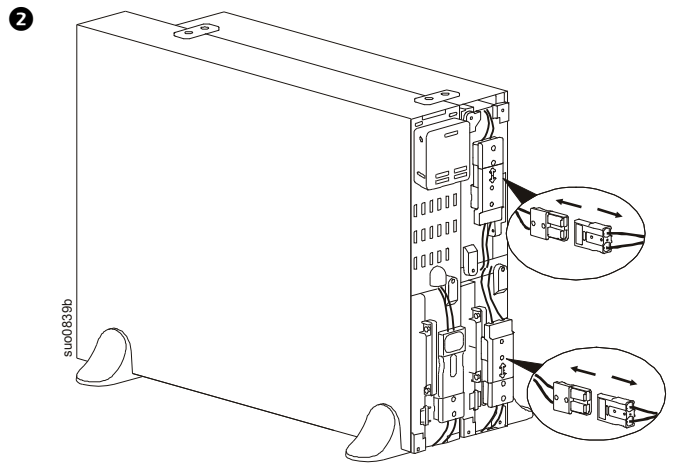
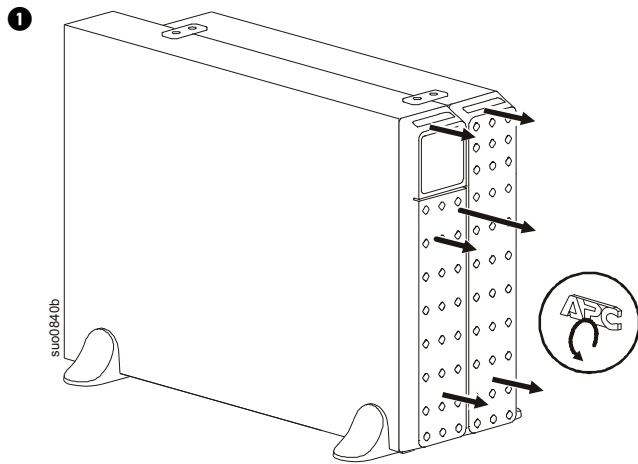

6 Disconnect and remove the battery module from the UPS. See “Tower to Rack-Mount Conversion of UPS” on page 2.

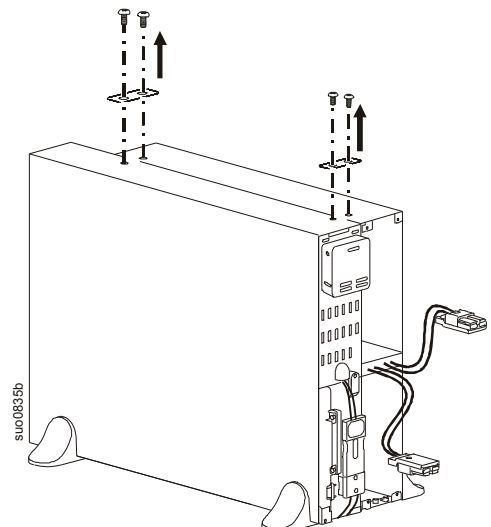

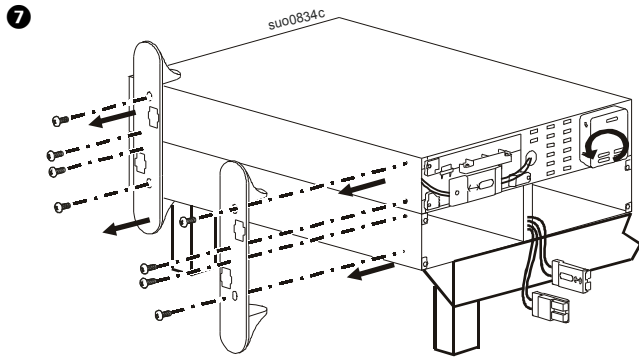

Install UPS with one External Battery Pack in a Rack

UPS model may differ in appearance from those depicted in these graphics. The XLBP installation process is identical for all models.

Refer to the rail kit Installation Guide for instructions on rail installation.

CAUTION

DAMAGE TO EQUIPMENT OR PERSONNEL

- The equipment is heavy. Always practice safe lifting techniques adequate for the weight of the equipment.
- Always use the recommended number of screws to secure brackets to the XLBP.
- Always use the recommended number of screws to secure the XLBP to the rack.
- Always install the XLBP at the bottom of the rack.
- Always install the XLBP below the UPS in the rack.
- Use the battery module handle to slide the battery modules in or out of the XLBP.
- Do not use the battery module handle to lift or carry the battery module.

Failure to follow these instructions can result in equipment damage and minor or moderate injury.

- Secure two brackets to the XLBP. Use three screws for each bracket.
 - Secure the cleat to the XLBP. Use four screws for each cleat.
- Rest the XLBP on the rail shelves.
 - Slide the XLBP into the rack.

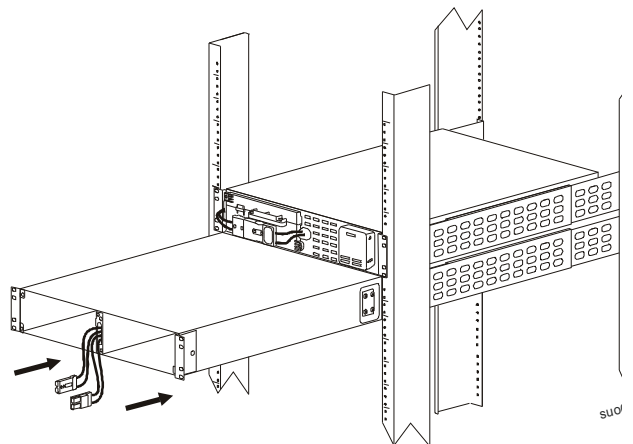
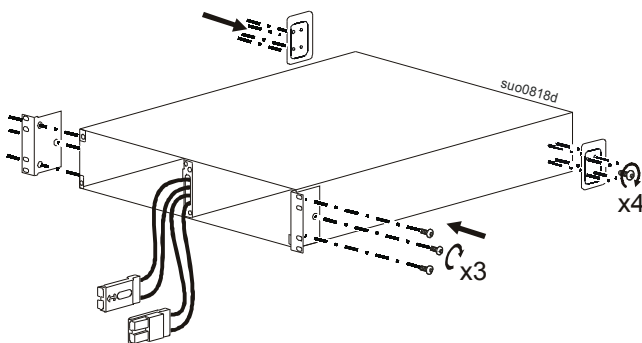

- 3 Secure the XLBP to the rack.
Use two screws in each bracket.

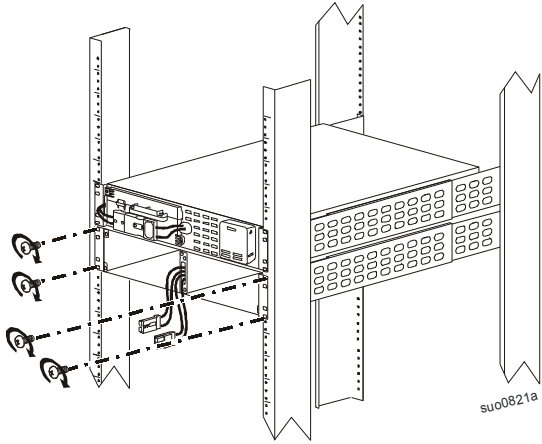

- 4 Slide the left hand side battery module into the XLBP.

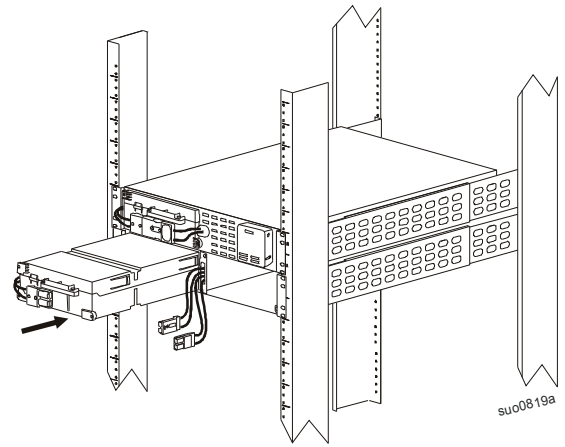

- 5 Slide the right hand side battery module into the XLBP.

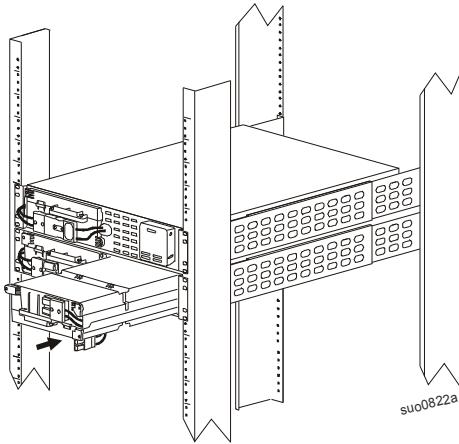

- 6 Secure the RBCs to the enclosure. Use three screws on each RBC.

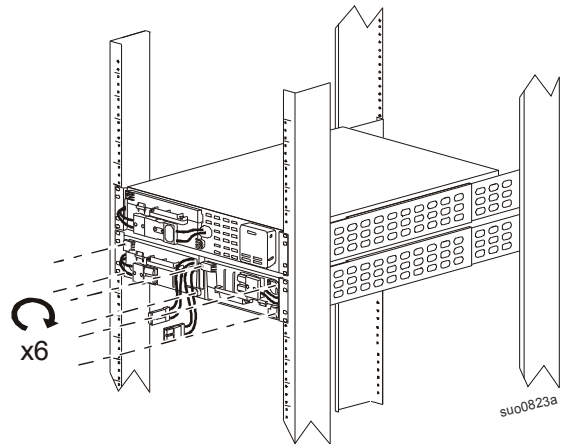

- 7 Connect the two XLBP connectors from the enclosure to the two RBCs. See "XLBP Connectors Installation" on page 8.

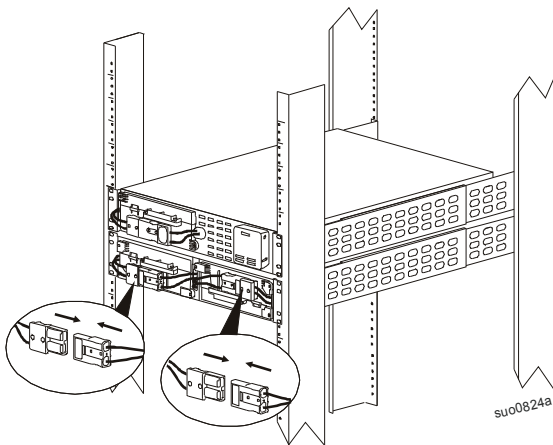

- 8 Install one XLBP bezel and one UPS bezel.

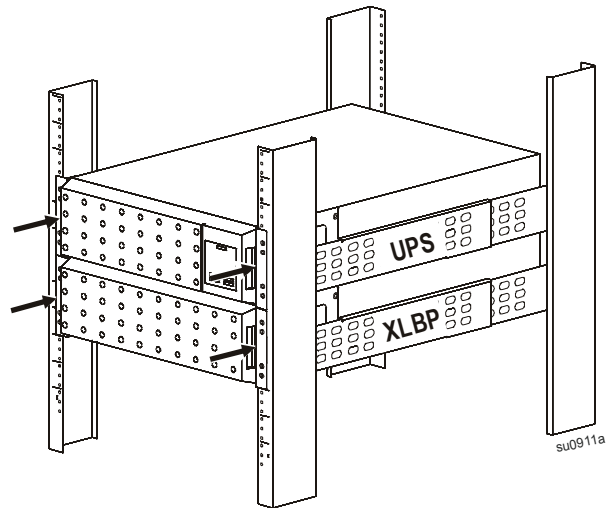

XLBP Connectors Installation

Connect the XLBP connector, labeled RBC 1, to the right hand side (RHS) RBC in rack-mount installation and to the top RBC in tower installation, when viewed from front.

Connect the XLBP connector, labeled RBC 2, to the left hand side (LHS) RBC in rack-mount installation and to the bottom RBC in tower installation, when viewed from front.

SRT1000/SRT1500

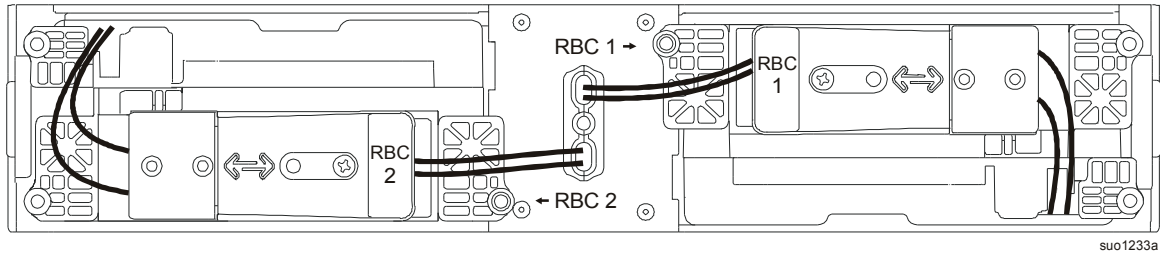

su01233a

SRT2200/SRT3000

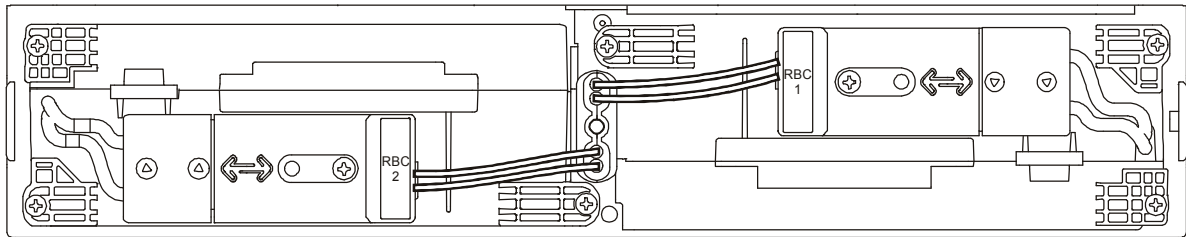

su01097a

Customer support and warranty information is available at the APC by Schneider Electric web site, www.apc.com.

© 2017 APC by Schneider Electric. APC, the APC logo, and Smart-UPS are owned by Schneider Electric Industries S.A.S., or their affiliated companies. All other trademarks are property of their respective owners.

EN 990-5649B
4/2017

Данный компонент на территории Российской Федерации

Вы можете приобрести в компании MosChip.

Для оперативного оформления запроса Вам необходимо перейти по данной ссылке:

<http://moschip.ru/get-element>

Вы можете разместить у нас заказ для любого Вашего проекта, будь то серийное производство или разработка единичного прибора.

В нашем ассортименте представлены ведущие мировые производители активных и пассивных электронных компонентов.

Нашей специализацией является поставка электронной компонентной базы двойного назначения, продукции таких производителей как XILINX, Intel (ex.ALTERA), Vicor, Microchip, Texas Instruments, Analog Devices, Mini-Circuits, Amphenol, Glenair.

Сотрудничество с глобальными дистрибьюторами электронных компонентов, предоставляет возможность заказывать и получать с международных складов практически любой перечень компонентов в оптимальные для Вас сроки.

На всех этапах разработки и производства наши партнеры могут получить квалифицированную поддержку опытных инженеров.

Система менеджмента качества компании отвечает требованиям в соответствии с ГОСТ Р ИСО 9001, ГОСТ РВ 0015-002 и ЭС РД 009

Офис по работе с юридическими лицами:

105318, г.Москва, ул.Щербаковская д.3, офис 1107, 1118, ДЦ «Щербаковский»

Телефон: +7 495 668-12-70 (многоканальный)

Факс: +7 495 668-12-70 (доб.304)

E-mail: info@moschip.ru

Skype отдела продаж:

moschip.ru

moschip.ru_4

moschip.ru_6

moschip.ru_9