

Ceramic Chip Trimmer Capacitors

**J Series
Outperforms
All Other Similar
Trimmers**

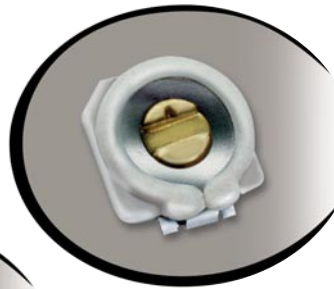

**JZ
Series**



**JR
Series**

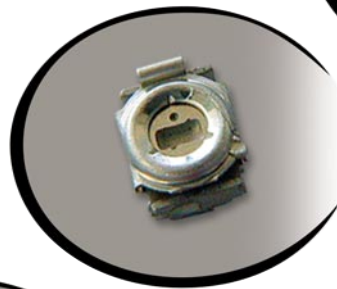

**JV
Series**

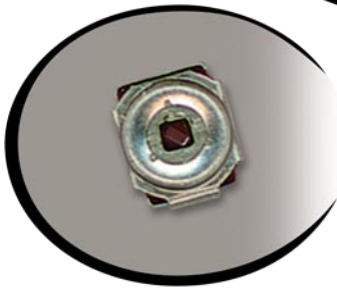

**JQ
Series**

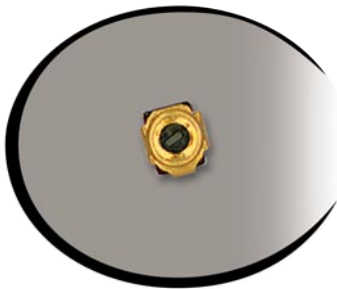

**JN
Series**

Most Stable Over Time

- <1% Capacitance Drift
- High Q Performance
- Tape & Reel Format
- In Stock and Ready to Ship

**Introducing the JZ_HV and JR_HV Series:
High Voltage in a small package design!**





2250 Northwood Drive
Salisbury, Maryland 21801
Phone: 410.749.2424
www.voltronicscorp.com

We now offer our JZ and JR series in a High-Voltage package: the JZ_HV and JR_HV. See pages 3 and 5 respectively for further details and be sure to order your engineering kits today!

Dear Valued Customer:

Voltronics has been offering high-performance, high Q, half-turn trimmer capacitors for over two decades. The J-Series is a proven performer that delivers uncompromising stability for even the most demanding applications, such as RFID, medical devices, cellular technologies, and much more.

In years prior, we offered the J-Series exclusively to the United States but through recent acquisition as the manufacturer, we now supply the entire line worldwide.

As indicated in the pages of this brochure, we offer the series in a variety of packages and specifications. Some additional information about the J-Series includes the following:

- We have sold tens of millions of J-Series components.
- They are the component of choice in thousands of designs worldwide.
- We offer direct-cross replacements for Sanshin part numbers.
- We offer engineering kits for all our J-Series components.

When your design demands indiscriminate performance, and when reliability becomes a high priority, choose the very best, which is the Voltronics J-Series ceramic chip trimmer capacitors.

Sincere regards,

The Voltronics Team



**World-Class Technology
Worldwide Availability**

Product Selection Guide

Product Line	Actual Size Length x Width x Height	Part Number	Cap. Range		Temperature Coefficient	SRF GHz	Mounting	Page
			Min.	Max. pF				
JZ and JZ_HV*		JZ030	1.5	– 3.0	0±200	2.1	Surface	2 & 3
		JZ060	2.0	– 6.0	0±300	1.5		
	.177 x .126 x .059 in	JZ080	3.0	– 8.0	–750±500	1.25		
	4.5 x 3.2 x 1.5 mm	JZ100	2.0	– 10.0	0±300	1.16		
		JZ150	3.0	– 15.0	0±300	0.92		
		JZ200	4.5	– 20.0	0±500	0.81		
		JZ300	5.5	– 30.0	–750±500	0.7		
		JZ400	8.0	– 40.0	–750±500	0.6		
* Note: We now offer the series in a HIGH VOLTAGE VERSION. The JZ_HV series specifications are identical to the specifications listed above with this important exception: DC Working Voltage 350DC, Withstanding Voltage 750.								
JR and JR_HV*		JR030	1.5	– 3.0	0±200	2.9	Surface	4 & 5
		JR060	2.0	– 6.0	0±300	2.05		
	.138 x .122 x .045 in	JR080	3.0	– 8.0	–750±500	1.8		
	3.5 x 3.1 x 1.15 mm	JR100	2.0	– 10.0	0±300	1.6		
		JR150	3.0	– 15.0	0±500	1.3		
		JR200	4.5	– 20.0	0±500	1.15		
		JR300	5.5	– 30.0	–750±500	0.92		
		JR400	8.0	– 40.0	–750±500	0.84		
* Note: We now offer the series in a HIGH VOLTAGE VERSION. The JR_HV series specifications are identical to the specifications listed above with this important exception: DC Working Voltage 350DC, Withstanding Voltage 750.								
JV		JV010	0.5	– 1.0	0±300	4.6	Surface	6
		JV025	0.65	– 2.5	0±300	2.9		
	.126 x .098 x .049 in	JV030	1.5	– 3.0	0±300	2.6		
	3.2 x 2.5 x 1.25 mm	JV060	2.5	– 6.0	0±300	1.9		
		JV100	3.0	– 10.0	0±300	1.4		
		JV200	4.5	– 20.0	–750±500	1.0		
		JV250	5.5	– 25.0	–750±500	0.9		
		JV450	8.0	– 45.0	–1000±500	0.6		
JQ		JQ060	3.0	– 6.0	0±300	1.6	Surface	7
	.106 x .087 x .04 in	JQ100	3.5	– 10.0	0±300	1.2		
	2.7 x 2.2 x 1.0 mm	JQ200	7.0	– 20.0	–750±500	0.9		
JN		JN010	0.55	– 1.0	0±300	6.0	Surface	8
		JN015	0.7	– 1.5	0±300	4.8		
	.067 x .059 x .035 in	JN040	1.5	– 4.0	0±500	2.7		
	1.7 x 1.5 x 0.9 mm	JN080	3.0	– 8.0	–750±500	1.8		
Engineering Kits and Q Data Charts								9

JZ SERIES - Ceramic Chip Trimmer Capacitors

General Specifications

Part Number	JZ030	JZ060	JZ080	JZ100	JZ150	JZ200	JZ300	JZ400	
Capacitance (pF)	Minimum	1.5	2.0	3.0	2.0	3.0	4.5	5.5	8.0
	Maximum	3.0 ^{+50%} _{-0%}	6.0 ^{+50%} _{-0%}	8.0 ^{+50%} _{-0%}	10.0 ^{+100%} _{-0%}	15.0 ^{+100%} _{-0%}	20.0 ^{+100%} _{-0%}	30.0 ^{+100%} _{-0%}	40.0 ^{+100%} _{-0%}
Marking Color	Black	Blue	Violet	White	Pink	Red	Orange	Yellow	
DC Working Voltage	125	125	125	125	125	125	125	125	
DC Withstanding Voltage	250	250	250	250	250	250	250	250	
Temperature Coefficient (ppm/°C)	0 ± 200	0 ± 300	-750 ± 500	0 ± 300	0 ± 300	0 ± 500	-750 ± 500	-750 ± 500	
Q (min.) at 1 MHz	500	1000	1500	1500	1500	1500	1500	1500	
Self Resonant Frequency at Maximum Rated Capacitance	2.1 GHz	1.5 GHz	1.25 GHz	1.16 GHz	0.92 GHz	0.81 GHz	0.70 GHz	0.60 GHz	
Insulation Resistance	10 ⁴ megohms								
Operating Temperature	-40°C to +85°C								
Torque	0.14 to 1.0 in-oz								
Packaging	All parts furnished on 12mm tape and reel. 1,000 pcs. per reel.								

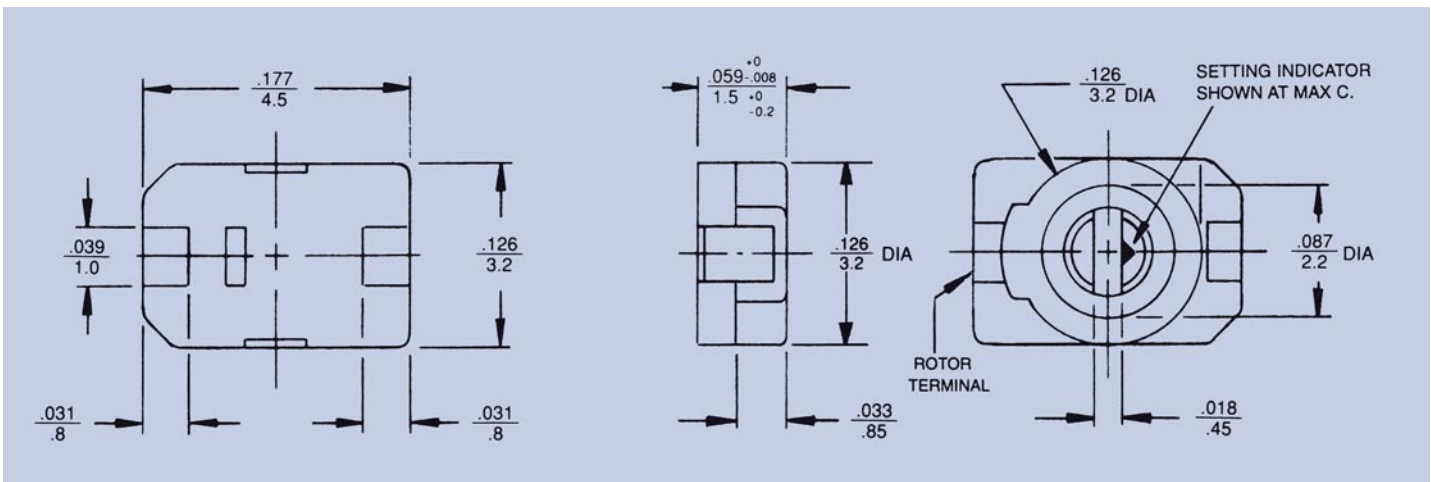

Drawing tolerances where not specified ± 0.008 in.
 ± 0.200 mm

SOLDER PAD LAYOUT

RECOMMENDED REFLOW SOLDER TEMPERATURE PROFILE FOR ALL J-SERIES TRIMMER CAPACITORS

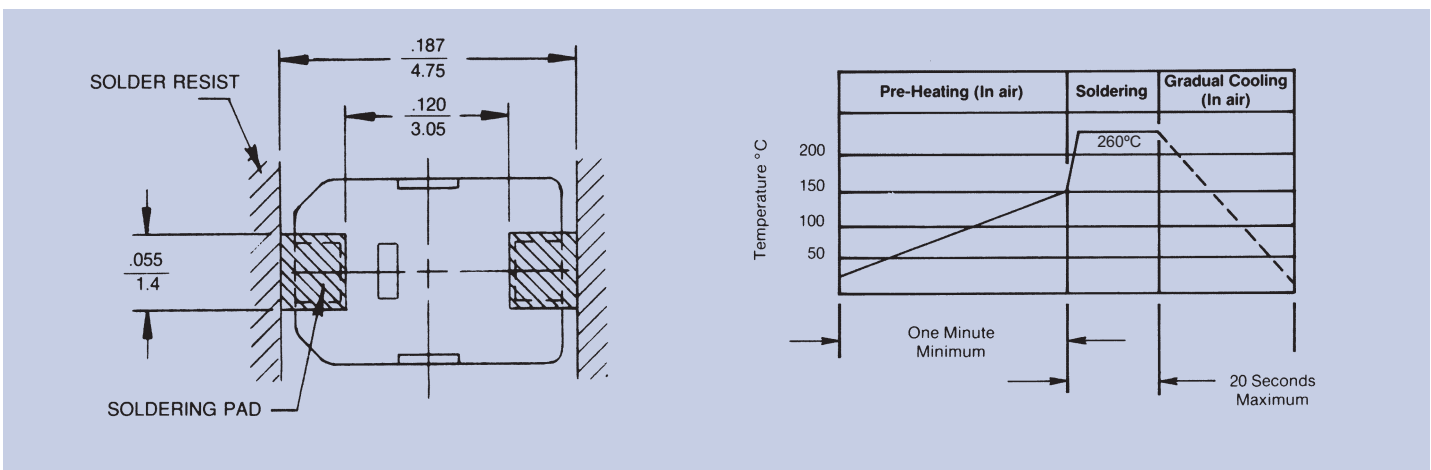

Recommended thickness of solder paste 0.15mm

JZ_HV SERIES - Ceramic Chip Trimmer Capacitors

General Specifications

Part Number	JZ030	JZ060	JZ080	JZ100	JZ150	JZ200	JZ300	JZ400	
Capacitance (pF)	Minimum	1.5	2.0	3.0	2.0	3.0	4.5	5.5	8.0
	Maximum	3.0 ^{+50%} _{-0%}	6.0 ^{+50%} _{-0%}	8.0 ^{+50%} _{-0%}	10.0 ^{+100%} _{-0%}	15.0 ^{+100%} _{-0%}	20.0 ^{+100%} _{-0%}	30.0 ^{+100%} _{-0%}	40.0 ^{+100%} _{-0%}
Marking Color	Black	Blue	Violet	White	Pink	Red	Orange	Yellow	
DC Working Voltage	350	350	350	350	350	350	350	350	
DC Withstanding Voltage	750	750	750	750	750	750	750	750	
Temperature Coefficient (ppm/°C)	0 ± 200	0 ± 300	-750 ± 500	0 ± 300	0 ± 300	0 ± 500	-750 ± 500	-750 ± 500	
Q (min.) at 1 MHz	500	1000	1500	1500	1500	1500	1500	1500	
Self Resonant Frequency at Maximum Rated Capacitance	2.1 GHz	1.5 GHz	1.25 GHz	1.16 GHz	0.92 GHz	0.81 GHz	0.70 GHz	0.60 GHz	
Insulation Resistance	10 ⁴ megohms								
Operating Temperature	-40°C to +85°C								
Torque	0.14 to 1.0 in-oz								
Packaging	All parts furnished on 12mm tape and reel. 1,000 pcs. per reel.								

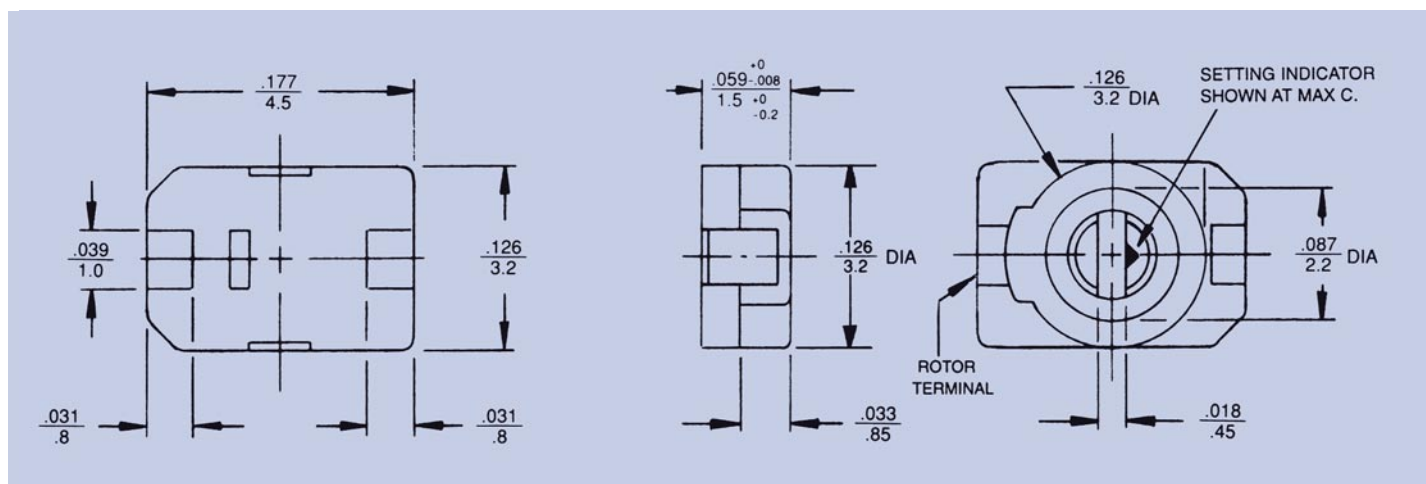

Drawing tolerances where not specified ± 0.008 in.
0.200 mm

SOLDER PAD LAYOUT

RECOMMENDED REFLOW SOLDER TEMPERATURE PROFILE FOR ALL J-SERIES TRIMMER CAPACITORS

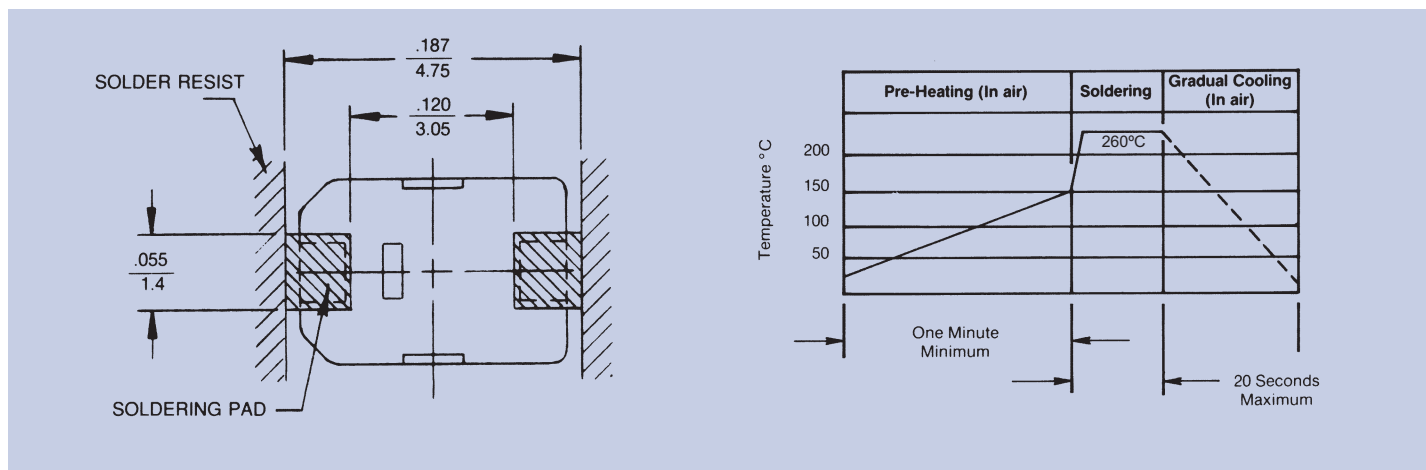

Recommended thickness of solder paste 0.15mm

JR SERIES - Ceramic Chip Trimmer Capacitors

General Specifications

Part Number	JR030	JR060	JR080	JR100	JR150	JR200	JR300	JR400	
Capacitance (pF)	Minimum	1.5	2.0	3.0	2.0	3.0	4.5	5.5	8.0
	Maximum	3.0 ^{+50%} _{-0%}	6.0 ^{+50%} _{-0%}	8.0 ^{+50%} _{-0%}	10.0 ^{+100%} _{-0%}	15.0 ^{+100%} _{-0%}	20.0 ^{+100%} _{-0%}	30.0 ^{+100%} _{-0%}	40.0 ^{+100%} _{-0%}
Marking Color	Black	Blue	Violet	None	Pink	Red	Orange	Yellow	
DC Working Voltage	125	125	125	125	125	125	125	125	
DC Withstanding Voltage	250	250	250	250	250	250	250	250	
Temperature Coefficient (ppm/°C)	0 ± 200	0 ± 300	-750 ± 500	0 ± 300	0 ± 500	0 ± 500	-750 ± 500	-750 ± 500	
Q (min.) at 1 MHz	500	1000	1500	1500	1500	1500	1500	1500	
Self Resonant Frequency at Maximum Rated Capacitance	2.9 GHz	2.05 GHz	1.8 GHz	1.6 GHz	1.3 GHz	1.15 GHz	0.92 GHz	0.84 GHz	
Insulation Resistance	10 ⁴ megohms								
Operating Temperature	-40°C to +85°C								
Torque	0.6 in-oz max.								
Packaging	All parts furnished on 12mm tape and reel. 1,000 pcs. per reel.								

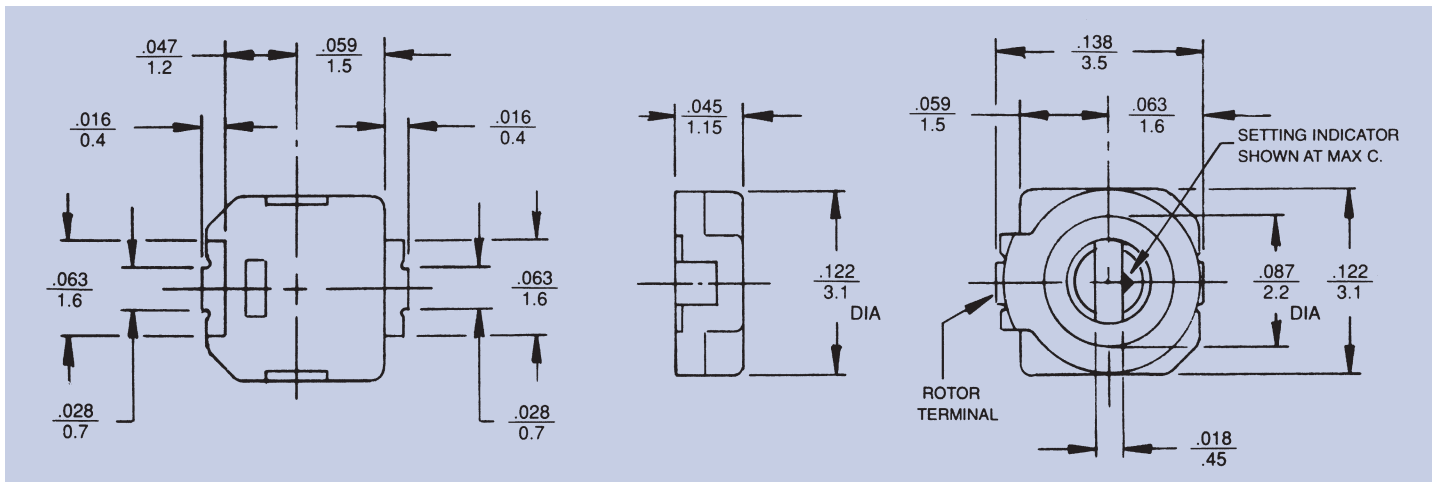

Drawing tolerances where not specified ± 0.008 in.
 ± 0.200 mm

SOLDER PAD LAYOUT

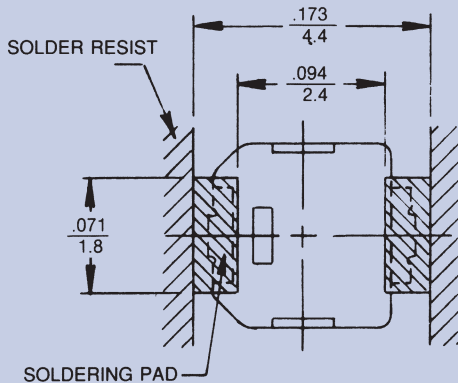

RECOMMENDED TUNING TOOLS FOR JZ AND JR SERIES

Metal Tipped: TT-400

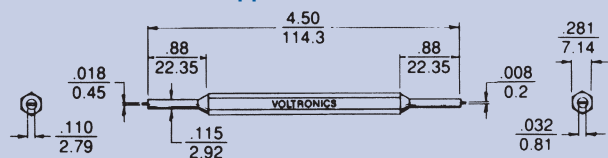

Ceramic Tipped: TT-900

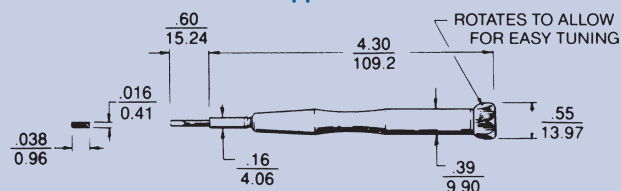

Recommended thickness of solder paste 0.15mm

JR_HV SERIES - Ceramic Chip Trimmer Capacitors

General Specifications

Part Number	JR030	JR060	JR080	JR100	JR150	JR200	JR300	JR400	
Capacitance (pF)	Minimum	1.5	2.0	3.0	2.0	3.0	4.5	5.5	8.0
	Maximum	3.0 ^{+50%} _{-0%}	6.0 ^{+50%} _{-0%}	8.0 ^{+50%} _{-0%}	10.0 ^{+100%} _{-0%}	15.0 ^{+100%} _{-0%}	20.0 ^{+100%} _{-0%}	30.0 ^{+100%} _{-0%}	40.0 ^{+100%} _{-0%}
Marking Color	Black	Blue	Violet	None	Pink	Red	Orange	Yellow	
DC Working Voltage	350	350	350	350	350	350	350	350	
DC Withstanding Voltage	750	750	750	750	750	750	750	750	
Temperature Coefficient (ppm/°C)	0 ± 200	0 ± 300	-750 ± 500	0 ± 300	0 ± 500	0 ± 500	-750 ± 500	-750 ± 500	
Q (min.) at 1 MHz	500	1000	1500	1500	1500	1500	1500	1500	
Self Resonant Frequency at Maximum Rated Capacitance	2.9 GHz	2.05 GHz	1.8 GHz	1.6 GHz	1.3 GHz	1.15 GHz	0.92 GHz	0.84 GHz	
Insulation Resistance	10 ⁴ megohms								
Operating Temperature	-40°C to +85°C								
Torque	0.6 in-oz max.								
Packaging	All parts furnished on 12mm tape and reel. 1,000 pcs. per reel.								

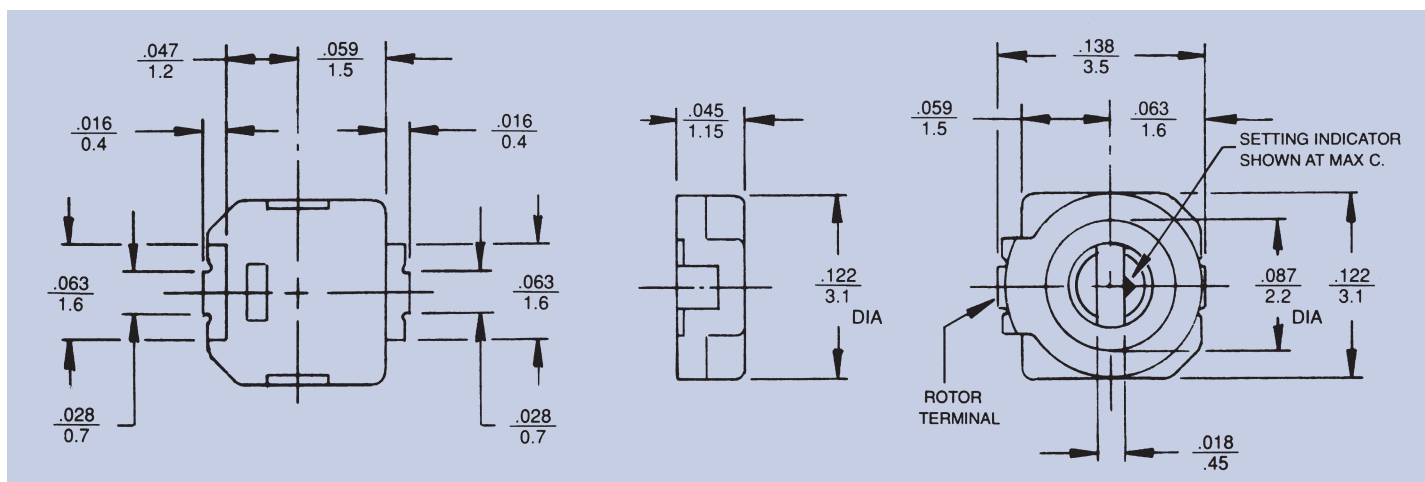

Drawing tolerances where not specified ± 0.008 in.
 ± 0.200 mm

SOLDER PAD LAYOUT

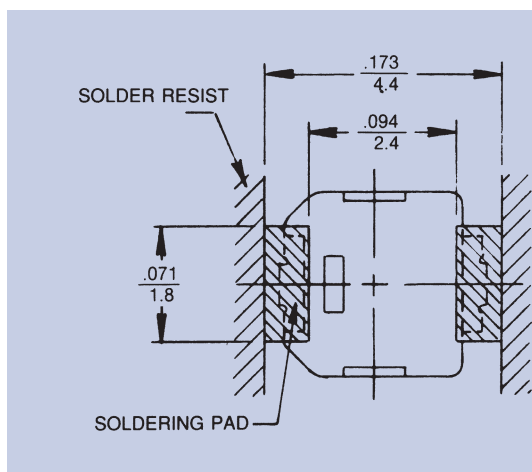

RECOMMENDED TUNING TOOLS FOR JZ AND JR SERIES

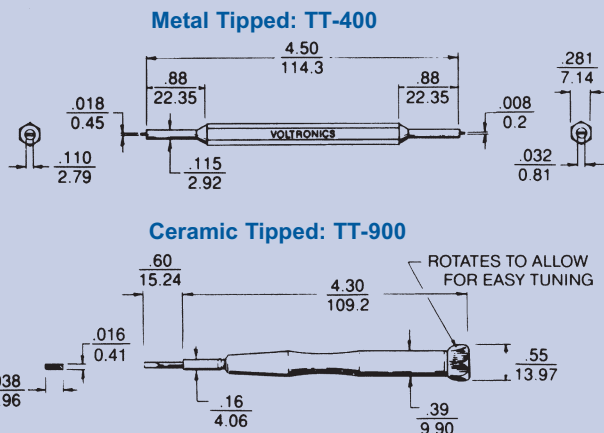

Recommended thickness of solder paste 0.15mm

JV SERIES - Ceramic Chip Trimmer Capacitors

General Specifications

Part Number	JV010	JV025	JV030	JV060	JV100	JV200	JV250	JV450	
Capacitance (pF)	Minimum	0.5	0.65	1.5	2.5	3.0	4.5	5.5	8.0
	Maximum	1.0 ^{+100%} _{-0%}	2.5 ^{+100%} _{-0%}	3.0 ^{+100%} _{-0%}	6.0 ^{+100%} _{-0%}	10.0 ^{+100%} _{-0%}	20.0 ^{+100%} _{-0%}	25.0 ^{+100%} _{-0%}	45.0 ^{+100%} _{-0%}
Marking Color	None	None	None	None	None	None	None	None	
DC Working Voltage	25	25	25	25	25	25	25	25	
DC Withstanding Voltage	55	55	55	55	55	55	55	55	
Temperature Coefficient (ppm/°C)	0±300	0 ±300	0±300	0±300	0±300	-750±500	-750 ±500	-1000±500	
Q (min.) at 1 MHz	500	500	500	500	500	500	300	300	
Self Resonant Frequency at Maximum Rated Capacitance	4.6 GHz	2.9 GHz	2.6 GHz	1.9 GHz	1.4 GHz	1.0 GHz	0.9 GHz	0.6 GHz	
Insulation Resistance	10 ⁴ megohms								
Operating Temperature	-25°C to +85°C								
Torque	0.6 in-oz max.								
Packaging	All parts furnished on 8mm tape and reel. 2,000 pcs. per reel.								

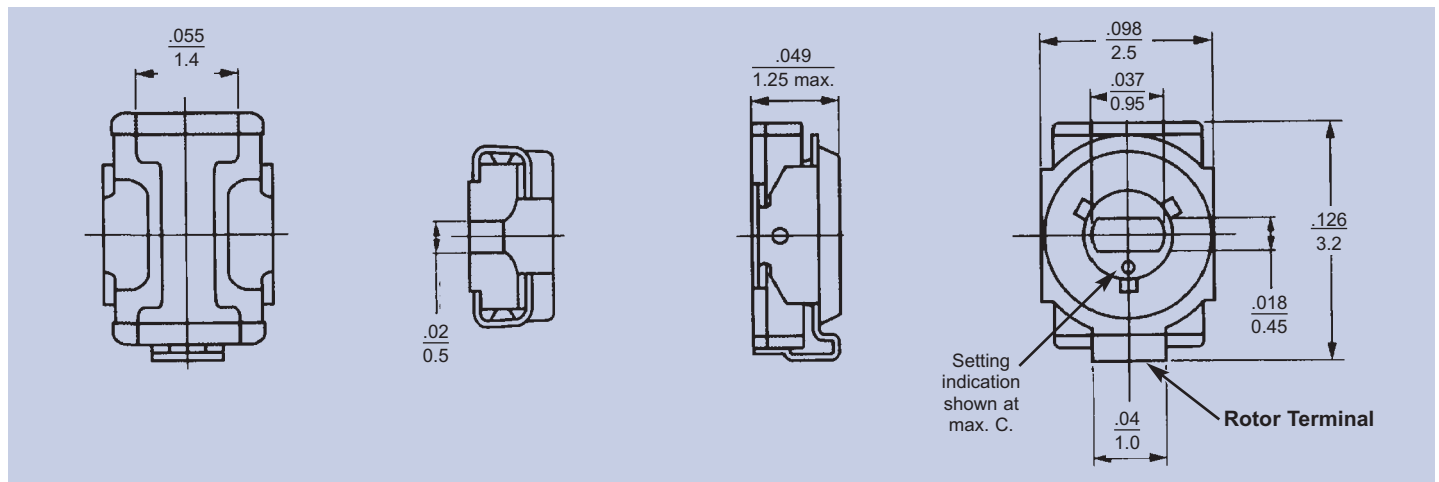

Drawing tolerances where not specified ± 0.020 in.
 ± 0.500 mm

SOLDER PAD LAYOUT

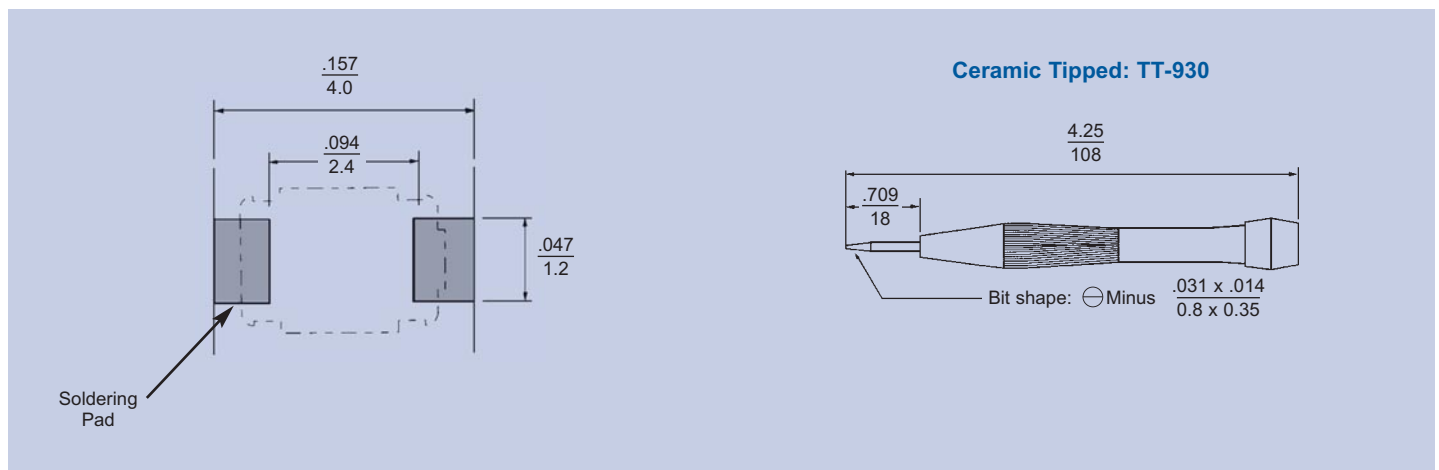

Recommended thickness of solder paste 0.15mm

JQ SERIES - Ceramic Chip Trimmer Capacitors

General Specifications

Part Number	JQ060	JQ100	JQ200
Capacitance (pF) Minimum	3.0	3.5	7.0
Capacitance (pF) Maximum	6.0 ^{+100%} _{-0%}	10.0 ^{+100%} _{-0%}	20.0 ^{+100%} _{-0%}
Marking Color	None	None	None
DC Working Voltage	25	25	25
DC Withstanding Voltage	55	55	55
Temperature Coefficient (ppm/°C)	0 ± 300	0 ± 300	-750 ± 500
Q (min.) at 1 MHz	500	500	500
Self Resonant Frequency at Maximum Rated Capacitance	1.6 GHz	1.2 GHz	0.9 GHz
Insulation Resistance	10 ⁴ megohms		
Operating Temperature	-25°C to +85°C		
Torque	.07 to 7.0 in-oz		
Packaging	All parts furnished on 8mm tape and reel. 3,000 pcs. per reel.		

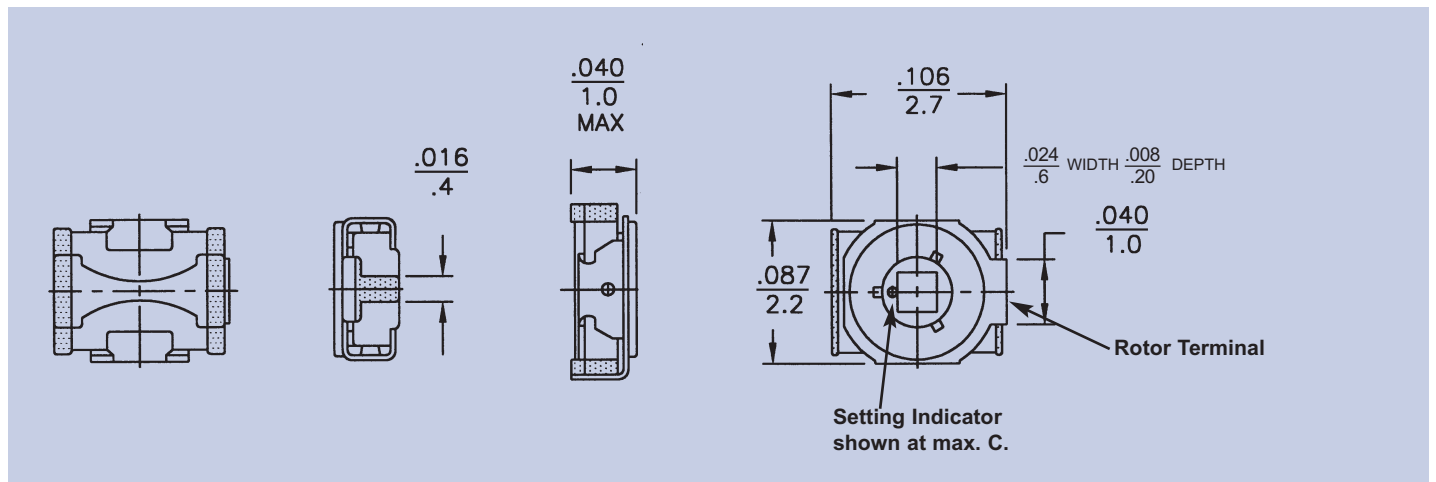

Drawing tolerances where not specified ± 0.020 in.
± 0.500 mm

SOLDER PAD LAYOUT

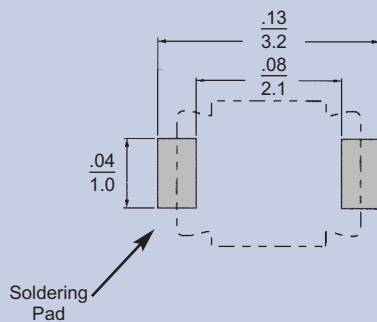

Recommended thickness of solder paste 0.15mm

RECOMMENDED TUNING TOOL FOR JQ SERIES

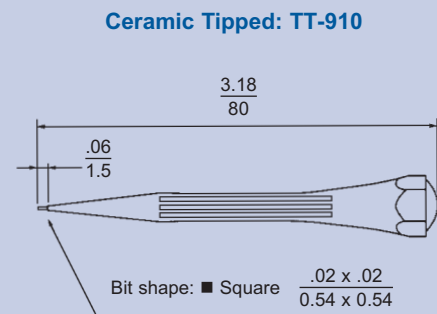

JN SERIES - Ceramic Chip Trimmer Capacitors

General Specifications

Part Number	JN010	JN015	JN040	JN080
Capacitance (pF)	0.55	0.7	1.5	3.0
Minimum				
Maximum	1.0 ^{+100%} _{-0%}	1.5 ^{+100%} _{-0%}	4.0 ^{+100%} _{-0%}	8.0 ^{+100%} _{-0%}
Marking Color	None	None	None	None
DC Working Voltage	25	25	25	25
DC Withstanding Voltage	55	55	55	55
Temperature Coefficient (ppm/°C)	0 ± 300	0 ± 300	0 ± 500	-750 ± 500
Q (min.) at 1 MHz	500	500	300	300
Self Resonant Frequency at Maximum Rated Capacitance	6.0 GHz	4.8 GHz	2.7 GHz	1.8 GHz
Insulation Resistance	10 ⁴ megohms			
Operating Temperature	-25°C to +85°C			
Torque	.014 to .14 in-oz			
Packaging	All parts furnished on 8mm tape and reel. 3,000 pcs. per reel.			

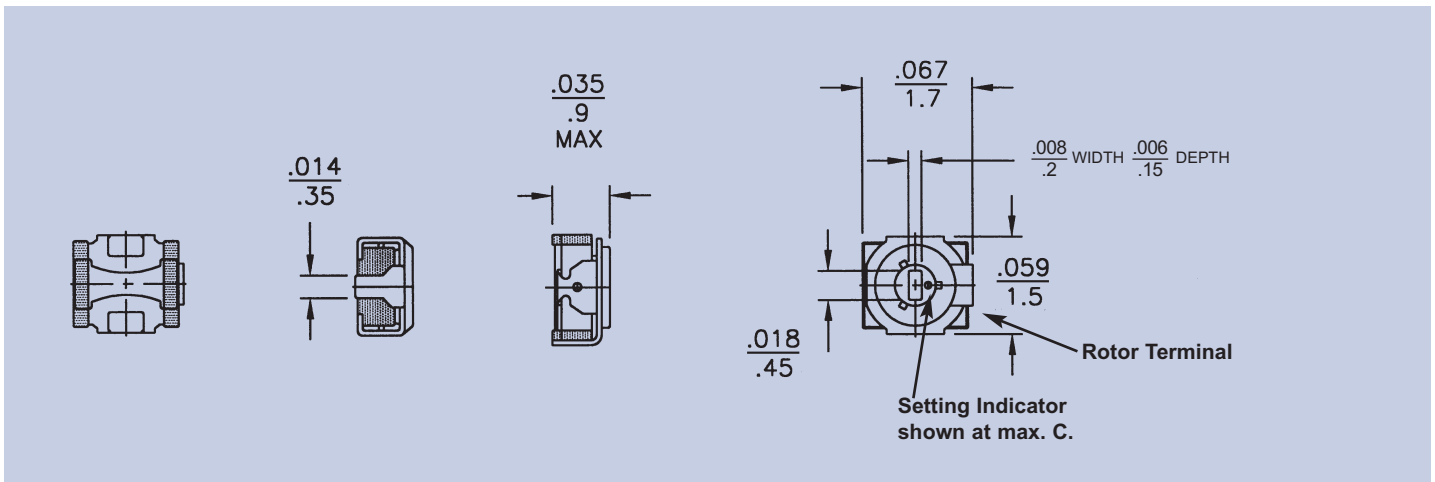

Drawing tolerances where not specified ± 0.020 in.
 ± 0.500 mm

SOLDER PAD LAYOUT

RECOMMENDED TUNING TOOL FOR JN SERIES

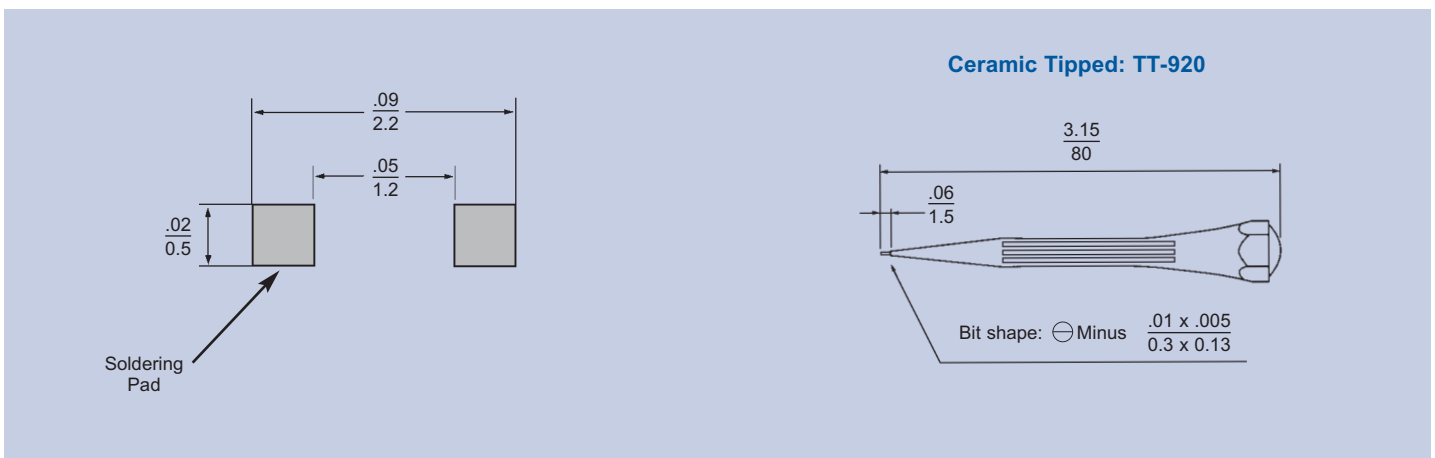

Recommended thickness of solder paste 0.15mm

Q DATA CHARTS & ENGINEERING KITS

**Quality Factor (Q)
of "JZ" Series Capacitors**

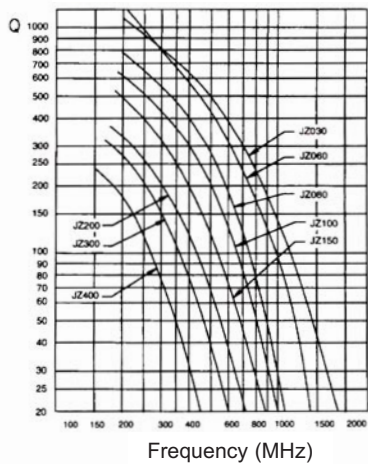

**Quality Factor (Q)
of "JR" Series Capacitors**

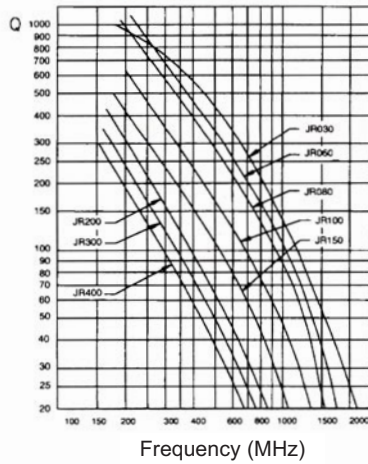

**Quality Factor (Q)
of "JV" Series Capacitors**

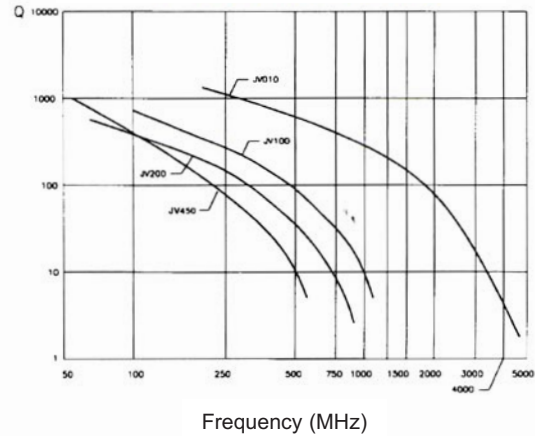

**Quality Factor (Q)
of "JQ" Series Capacitors**

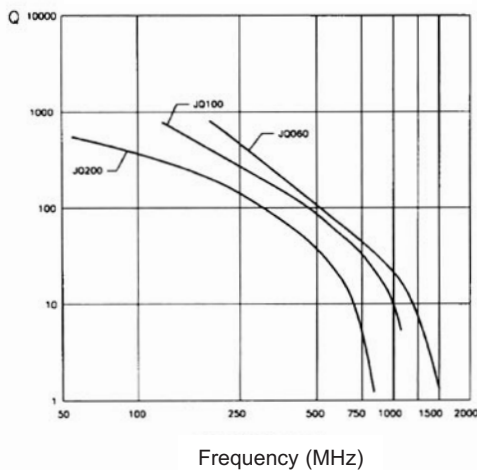

**Quality Factor (Q)
of "JN" Series Capacitors**

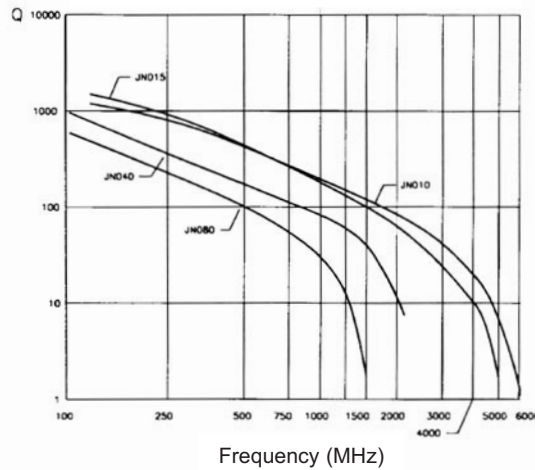

Engineering Kits

Kit #	Quantity	Description
JZ Kit*	4	Each Capacitance Range
JZ-HV Kit*		
JR Kit*	4	
JR-HV Kit*	4	
JV Kit**	5	
JQ Kit**	5	
JN Kit**	5	

J-Series engineering kits are a great way to become familiar with our products. Each kit contains 4 or 5 units of every value. Please be sure to inquire about tuning tools when ordering.
* Tuning tools are included with this kit.
** Tuning tools are not included with this kit. Please inquire about tuning tools when ordering.

Washing Instructions:

The J-Series trimmer capacitors can withstand cleaning cycles up to 10 PSI and have been used by customers for more than a decade in many diverse environmental conditions. Without knowing your particular washing or cleaning environment, we recommend these basic guidelines:

- 1) Water wash or isopropyl alcohol cleaning agents are acceptable providing that baths are clean and uncontaminated. For maximum effectiveness, the cleaning process should occur immediately after soldering.
- 2) Either brush or spray methods are acceptable.
- 3) *Drying out components with forced hot air is highly recommended.
- 4) Also, we do recommend turning the tuning screw 3 or 4 complete revolutions prior to arriving at the final "set."

* If a water wash process is used and water does get inside, we recommend that the parts be heated above 100C for a minimum of 15 minutes, so that the water evaporates. After this, the rotor should be turned 1-2 times to redistribute the internal grease.

BSC Filters Ltd,
Jorvik House, Outgang Lane, Osbaldwick, York YO19 5UP UK

Phone: +44 1904 438438
Fax: +44 1904 438123
Email: sales@bscfilters.com

Dielectric Laboratories, Inc
2777 Route 20 East, Cazenovia, NY 13035 USA

Phone: +1 315 655 8710
Fax: +1 315 655 0445
Email: sales@dilabs.com

Dow-Key Microwave
4822 McGrath Street, Ventura, CA 93003 USA

Phone: +1 805 650 0260
Fax: +1 805 650 1734
Email: askdk@dowkey.com

K&L Microwave
2250 Northwood Drive, Salisbury, MD 21801 USA

Phone: +1 410 749 2424
Fax: +1 443 260 2268
Email: sales@klmicrowave.com

Novacap
25111 Anza Drive, Valencia, CA 91355 USA

Phone: +1 661 295 5920
Fax: +1 661 295 5928
Email: info@novacap.com

Pole/Zero Corporation
5558 Union Centre Drive, West Chester, OH 45069 USA

Phone: +1 513 870 9060
Fax: +1 513 870 9064
Email: support@polezero.com

Syfer Technology Limited
Old Stoke Road, Arminghall, Norwich, NR14 8SQ UK

Phone: +44 1603 723300
Fax: +44 1603 723301
Email: sales@syfer.co.uk

Voltronics Corporation
2250 Northwood Drive, Salisbury, MD 21801

Phone : +1 410 749 2424
Fax: +1 443 260 2263
email: info@voltronicscorp.com



www.dovercmp.com

Ceramic & Microwave Products (CMP) designs, manufactures and sells special electronic components and systems, including high-performance filters, switches, capacitors and EMI and cosite signal interference solutions. Our products are used in military, space, telecom infrastructure, medical and industrial applications where function and reliability are crucial.

Mouser Electronics

Authorized Distributor

Click to View Pricing, Inventory, Delivery & Lifecycle Information:

[Voltronics:](#)

[JZ400HV](#) [JZ300HV](#)

Данный компонент на территории Российской Федерации

Вы можете приобрести в компании MosChip.

Для оперативного оформления запроса Вам необходимо перейти по данной ссылке:

<http://moschip.ru/get-element>

Вы можете разместить у нас заказ для любого Вашего проекта, будь то серийное производство или разработка единичного прибора.

В нашем ассортименте представлены ведущие мировые производители активных и пассивных электронных компонентов.

Нашей специализацией является поставка электронной компонентной базы двойного назначения, продукции таких производителей как XILINX, Intel (ex.ALTERA), Vicor, Microchip, Texas Instruments, Analog Devices, Mini-Circuits, Amphenol, Glenair.

Сотрудничество с глобальными дистрибьюторами электронных компонентов, предоставляет возможность заказывать и получать с международных складов практически любой перечень компонентов в оптимальные для Вас сроки.

На всех этапах разработки и производства наши партнеры могут получить квалифицированную поддержку опытных инженеров.

Система менеджмента качества компании отвечает требованиям в соответствии с ГОСТ Р ИСО 9001, ГОСТ РВ 0015-002 и ЭС РД 009

Офис по работе с юридическими лицами:

105318, г.Москва, ул.Щербаковская д.3, офис 1107, 1118, ДЦ «Щербаковский»

Телефон: +7 495 668-12-70 (многоканальный)

Факс: +7 495 668-12-70 (доб.304)

E-mail: info@moschip.ru

Skype отдела продаж:

moschip.ru

moschip.ru_4

moschip.ru_6

moschip.ru_9