

### INTRODUCTIONS

1. Designed to meet globally accepted IEC publication 320 Class 1, that allows users to comply with industry standard in power entry requirement.
2. Connector for cold condition, with pin temperature 70°C max.
3. Nickel-plated brass pins and soldering terminals.
4. Snap-in mount (panel thickness: 0.04 inch to 0.07 inch).
5. Power module in plastic or metal case that incorporates an IEC connector, IEC 5x20mm fuse holder, power switch and voltage selector switch, all-in-one easy-to-install unit.  
Part numbers 06A1, 06A2, 06A2D and 06A5 are power modules in plastic case; part numbers 06AN2, 06AN2D, 06AN3, 06AN3D and 06AN5 are power modules in metal case.
6. Fuse holder designed for one fuse. Safety interlock prevents fuse removal with line plug inserted.
7. Adapts to 110V or 220V input voltage with voltage selector switch.
8. Compact design and high volume production provide maximum flexibility and significant savings in space and cost over assembly of individual components.
9. All part numbers are UL recognized, CSA certified and SEMKO approved.

### SPECIFICATIONS

1. Rated voltage: 115VAC/250VAC
2. Maximum leakage current each line-to-ground  
2uA AT 115VAC/60Hz  
5uA AT 250VAC/50Hz
3. Dielectric strength (one minute)  
line-to-ground: 2250VDC  
line-to-line: 1450VDC
4. Flammability class: UL 94V-0

### ELECTRICAL SCHEMATIC



### TYPE & RATED CURRENT

DELTA PART NUMBER		06A1	06A2	06A2D	06A5	REMARKS: * 1. SINGLE-POLE POWER SWITCH UL/CSA APPROVED AT 6A, 125VAC/250VAC VDE APPROVED AT 6A/250VAC ELECTRICAL LIFETIME: 50,000 CYCLES MAXIMUM IN-RUSH CURRENT: 70A * 2. DOUBLE-POLE POWER SWITCH ELECTRICAL LIFETIME: 10,000 CYCLES MAXIMUM IN-RUSH CURRENT: 50A * 3. VOLTAGE SELECTOR SWITCH UL/CSA APPROVED AT 6A/125VAC & 250VAC VDE APPROVED AT 6A/250VAC
RATED CURRENT	UL/CSA (115VAC/250VAC)	6A	6A	4A	6A	
	SEMKO					
CONNECTOR TYPE	MALE	△	△	△	△	
	FEMALE					
FUSE HOLDER		S	S	S	S	
POWER SWITCH		-	SP *1	DP *2	-	
VOLTAGE SELECTOR		-	-	-	FRONT *3	
ELECTRICAL SCHEMATIC		FIG. A	FIG. C	FIG. D	FIG. B	

DELTA PART NUMBER		06AN2	06AN2D	06AN3	06AN3D	06AN5	REMARKS: * 1. SINGLE-POLE POWER SWITCH UL/CSA APPROVED AT 6A, 125VAC/250VAC VDE APPROVED AT 6A/250VAC ELECTRICAL LIFETIME: 50,000 CYCLES MAXIMUM IN-RUSH CURRENT: 70A * 2. DOUBLE-POLE POWER SWITCH ELECTRICAL LIFETIME: 10,000 CYCLES MAXIMUM IN-RUSH CURRENT: 50A * 3. VOLTAGE SELECTOR SWITCH (FRONT) UL/CSA APPROVED AT 6A, 125VAC/250VAC VDE APPROVED AT 6A/250VAC * 4. VOLTAGE SELECTOR SWITCH (REAR) UL/CSA/VDE APPROVED AT 10A/125VAC & 5A/250VAC
RATED CURRENT	UL/CSA (115VAC/250VAC)	6A	6A			6A	
	SEMKO		4A				
CONNECTOR TYPE	MALE	△	△	△	△	△	
	FEMALE						
FUSE HOLDER		S	S	S	S	S	
POWER SWITCH		SP*1	DP *2	SP *1	DP *2	-	
VOLTAGE SELECTOR		-	-	REAR*4	REAR*4	FRONT *3	
ELECTRICAL SCHEMATIC		FIG. C	FIG. D	FIG. C	FIG. D	FIG. B	

## MECHANICAL CONSTRUCTION



06A5  
06A1 (Without voltage selector switch)

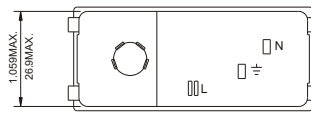
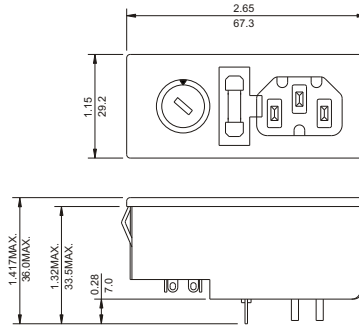

06A2

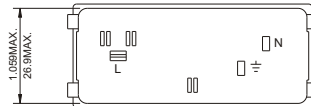
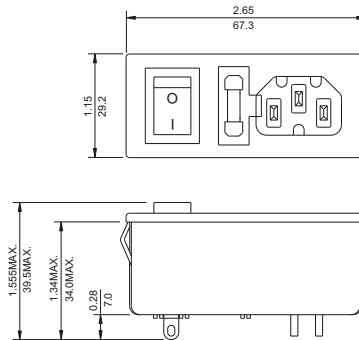

06A2D

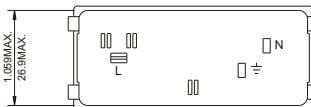
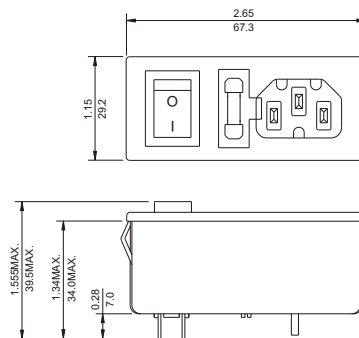

UNIT:  $\frac{\text{INCH}}{\text{mm}}$

# MECHANICAL CONSTRUCTION



06AN2  
06AN2D

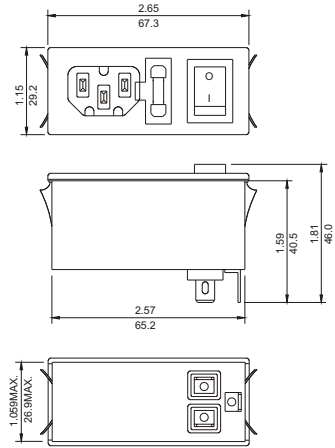

06AN3  
06AN3D

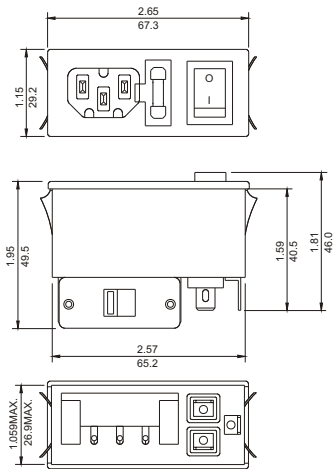

06AN5

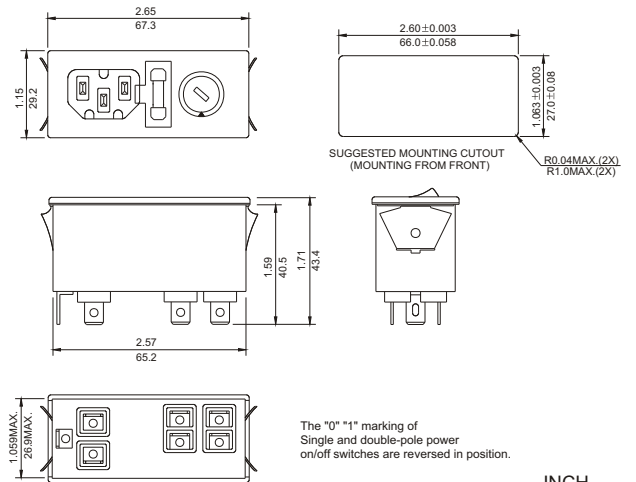

UNIT: INCH  
mm

POWER ENTRY MODULES

## Данный компонент на территории Российской Федерации

### Вы можете приобрести в компании MosChip.

Для оперативного оформления запроса Вам необходимо перейти по данной ссылке:

<http://moschip.ru/get-element>

Вы можете разместить у нас заказ для любого Вашего проекта, будь то серийное производство или разработка единичного прибора.

В нашем ассортименте представлены ведущие мировые производители активных и пассивных электронных компонентов.

Нашей специализацией является поставка электронной компонентной базы двойного назначения, продукции таких производителей как XILINX, Intel (ex.ALTERA), Vicor, Microchip, Texas Instruments, Analog Devices, Mini-Circuits, Amphenol, Glenair.

Сотрудничество с глобальными дистрибьюторами электронных компонентов, предоставляет возможность заказывать и получать с международных складов практически любой перечень компонентов в оптимальные для Вас сроки.

На всех этапах разработки и производства наши партнеры могут получить квалифицированную поддержку опытных инженеров.

Система менеджмента качества компании отвечает требованиям в соответствии с ГОСТ Р ИСО 9001, ГОСТ РВ 0015-002 и ЭС РД 009

### Офис по работе с юридическими лицами:

105318, г.Москва, ул.Щербаковская д.3, офис 1107, 1118, ДЦ «Щербаковский»

Телефон: +7 495 668-12-70 (многоканальный)

Факс: +7 495 668-12-70 (доб.304)

E-mail: [info@moschip.ru](mailto:info@moschip.ru)

Skype отдела продаж:

moschip.ru

moschip.ru\_4

moschip.ru\_6

moschip.ru\_9