

GT11 Series

— Connectors for coaxial cables —

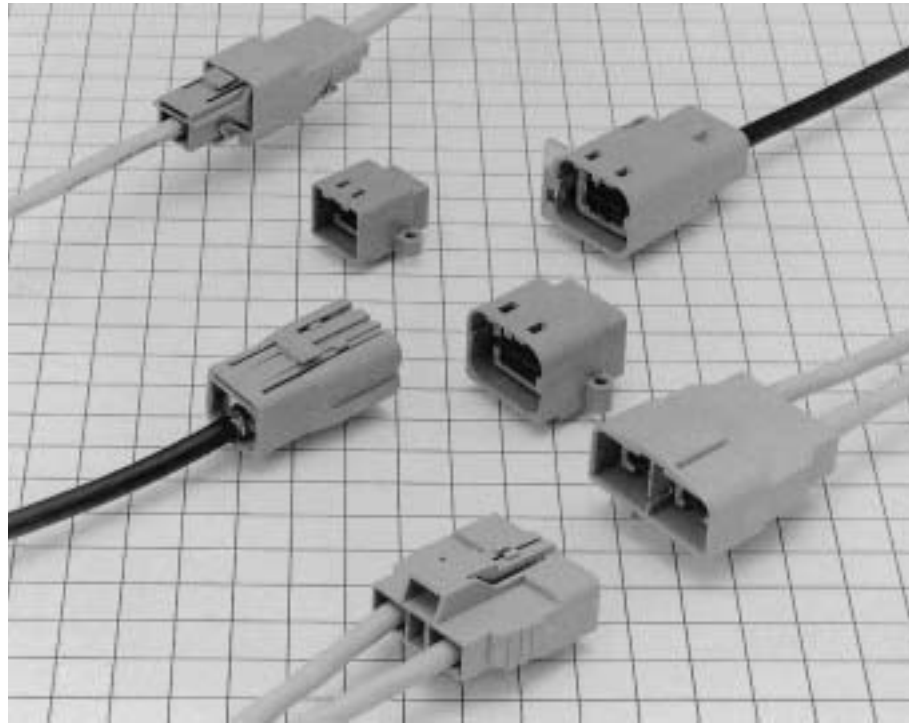

■ Features

- **Cost efficient termination**
Highly efficient and reliable single motion crimp termination allows high volume production with semi-automatic equipment.
- **Lock-release latching system**
- **Shock / vibration resistant electrical connections**
- **Verification of the full contact insertion**

For Double-Conductor coaxial shielded cable

F Connectors

● Outer terminals

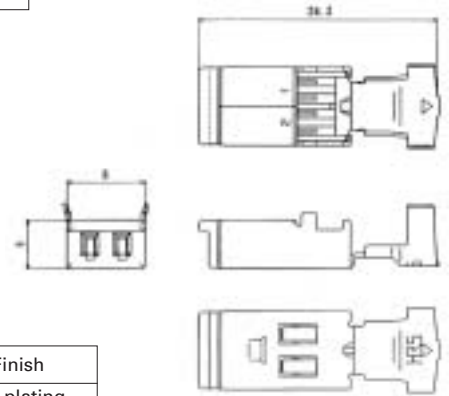

Part Number	CL No.	Applicable Cable
GT11-2S-5.2C	761-0002-3	4.5 to 5.2mm
GT11-2S-6.0C	761-0028-7	5.8 to 6.2mm

Item	Material	Finish
Outer terminal	Brass	Tin plating
Insulator	PT	Color: Dark gray

* The suitable terminals might differ depending on the internal structure of the cable.

● Inner Terminals

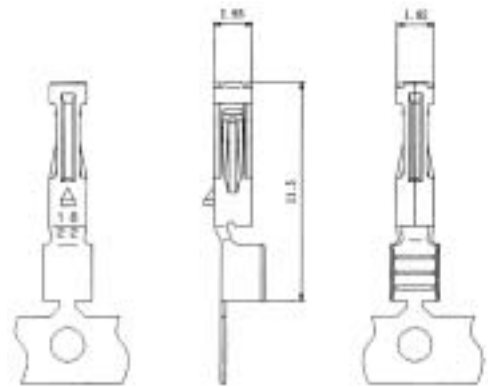

Part Number	CL No.	Conductor Size (AWG)	Material	Finish	Packaging
GT11-1822SCF	761-0004-9	#18 to 22	Brass	Tin plating	8,000 pcs. per reel
GT11-2428SCF	761-0020-5	#24 to 28			

M Connectors

● Outer terminals

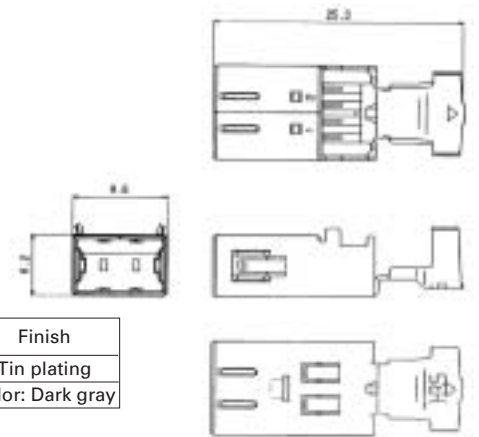

Part Number	CL No.	Applicable Cable
GT11-2P-5.2C	761-0001-0	4.5 to 5.2mm
GT11-2P-6.0C	761-0027-4	5.8 to 6.2mm

Item	Material	Finish
Outer terminal	Brass	Tin plating
Insulator	PT	Color: Dark gray

* The suitable terminals might differ depending on the internal structure of the cable.

● Inner Terminals

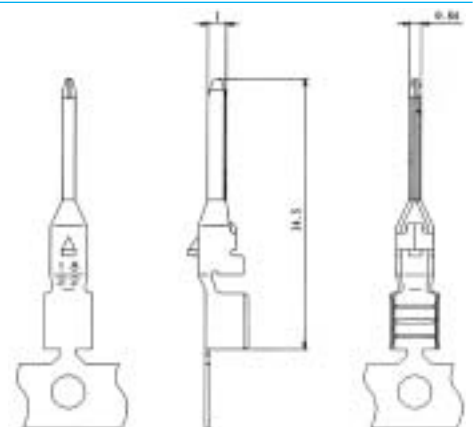

Part Number	CL No.	Conductor Size (AWG)	Material	Finish	Packaging
GT11-1822PCF	761-0003-6	#18 to 22	Brass	Tin plating	8,000 pcs. per reel
GT11-2428PCF	761-0019-6	#24 to 28			

For Double-Conductor coaxial cable

F Connectors

● Housing

◆ Shown with inserted retainer

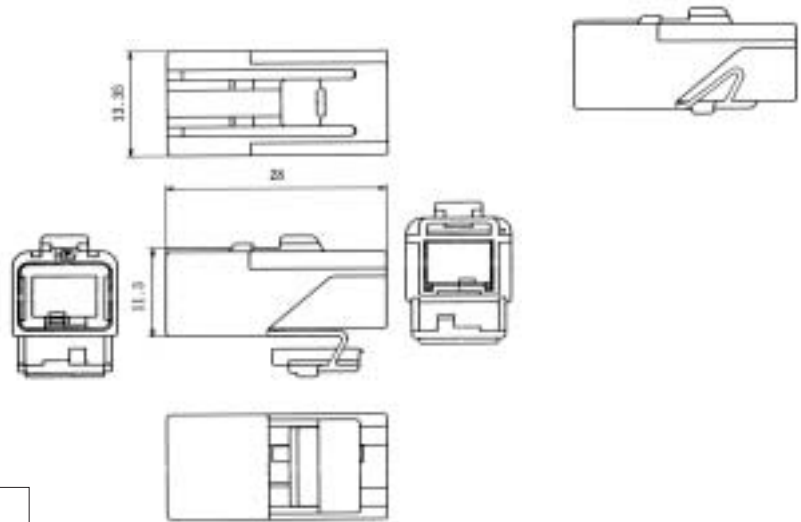

Part Number	CL No.	Material	Color
GT11-2S-HU	761-0005-1	PBT	Light gray

M Connectors

● Housing

◆ Shown with inserted retainer

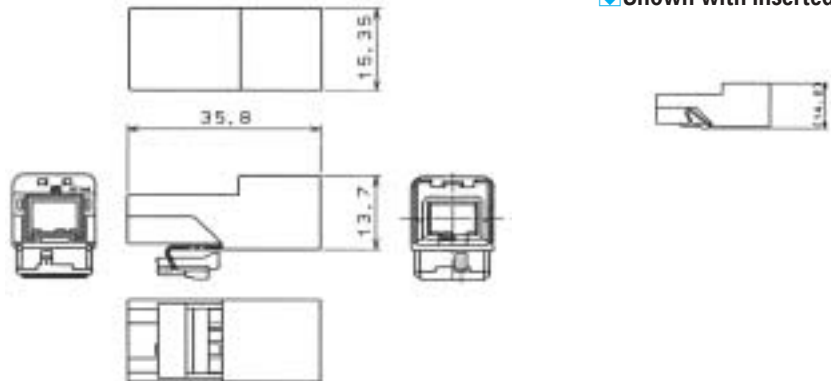

Part Number	CL No.	Material	Color
GT11-2P-HU	761-0006-4	PBT	Light gray



◆ Shown with inserted retainer

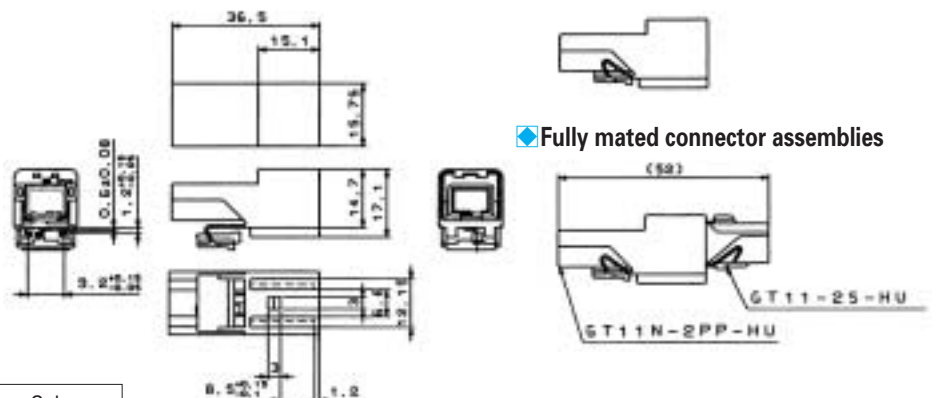

◆ Fully mated connector assemblies

Part Number	CL No.	Material	Color
GT11N-2PP-HU	761-0008-0	PBT	Light gray

M Connectors

● Housing

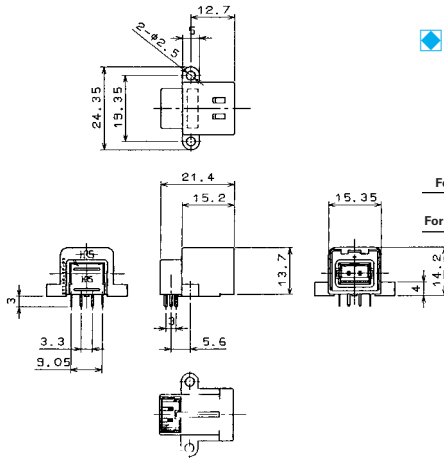

◆ Recommended Board Mounting Pattern

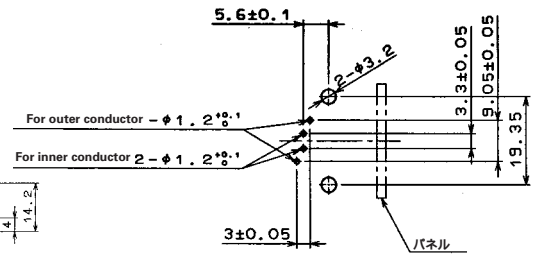

Part Number	CL No.	Material	Finish	Color
GT11-2S-HU	761-0005-1	PBT	—	Light gray
		Brass	Tin plating	—
		PBT	—	Dark gray
		Phosphor bronze	Tin plating	—

● Housing (2-position Type)

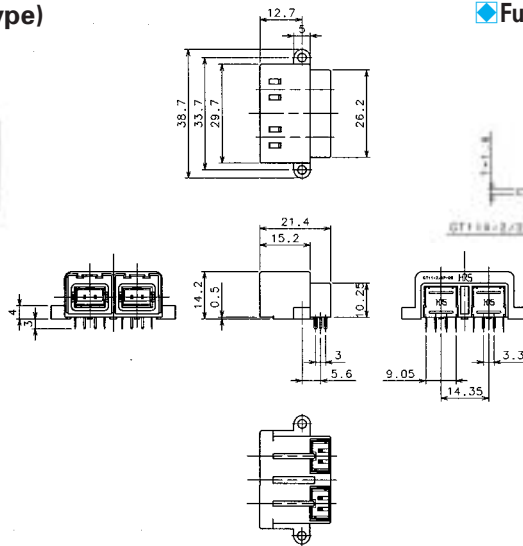

◆ Fully mated connector assemblies

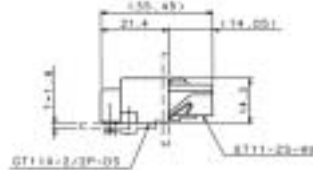

◆ Recommended Panel Cut-out



◆ Recommended Board Mounting Pattern

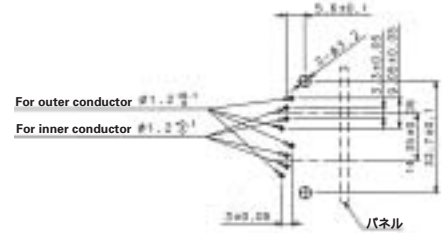

Part Number	CL No.	Material	Finish	Color
GT11X-2/2P-DS	761-0022-0	PBT	—	Light gray
		Brass	Tin plating	—
		PBT	—	Dark gray
		Phosphor bronze	Tin plating	—

● Housing (Straight Type)

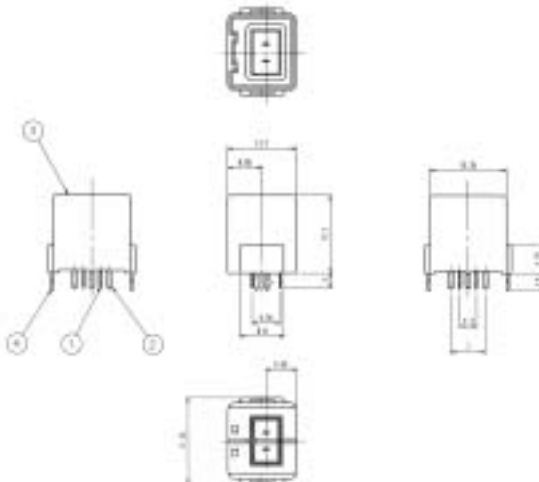

◆ Recommended Board Mounting Pattern

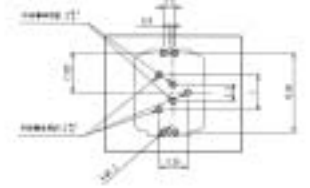

◆ Fully mated connector assemblies

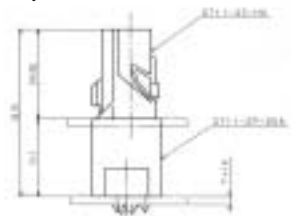

Part Number	CL No.
GT11-2P-DSA	761-0038-0

Waterproof type For Double-Conductor coaxial cable

F Connectors

● Housing

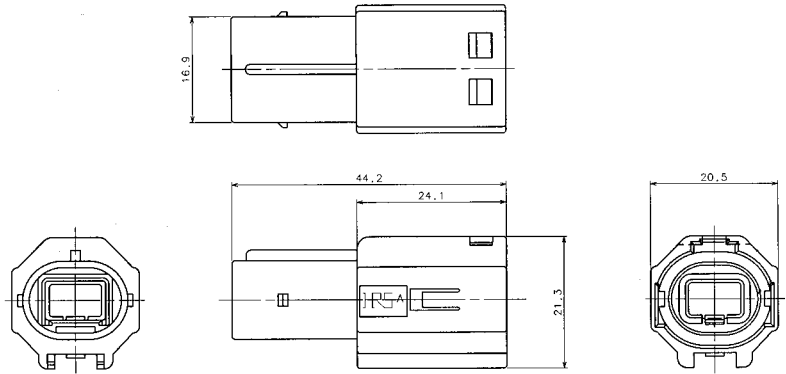

◆ Fully mated connector assemblies

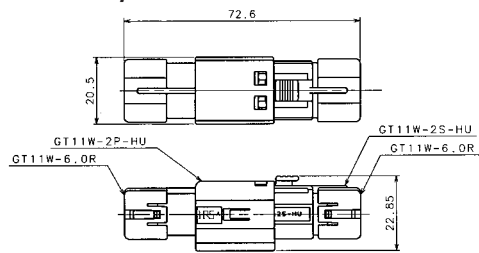

Part Number	CL No.	Material
GT11W-2P-HU	761-0023-3	PBT

M Connectors

● Housing

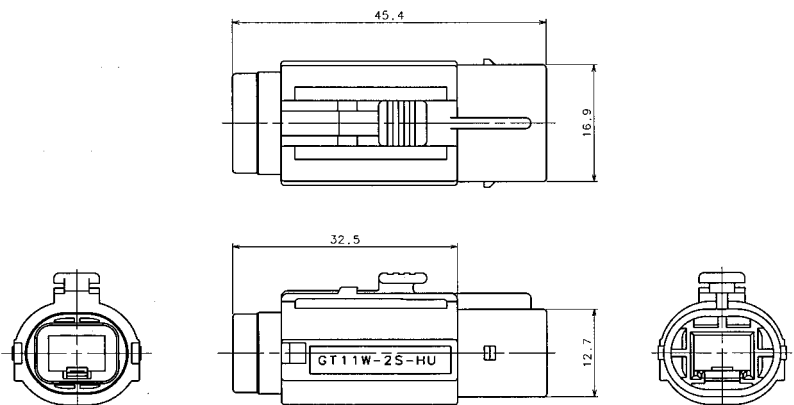

Part Number	CL No.	Material
GT11W-2S-HU	761-0024-6	PBT

● Retainer (used with GT11W-2S-HU and GT11W-2P-HU)

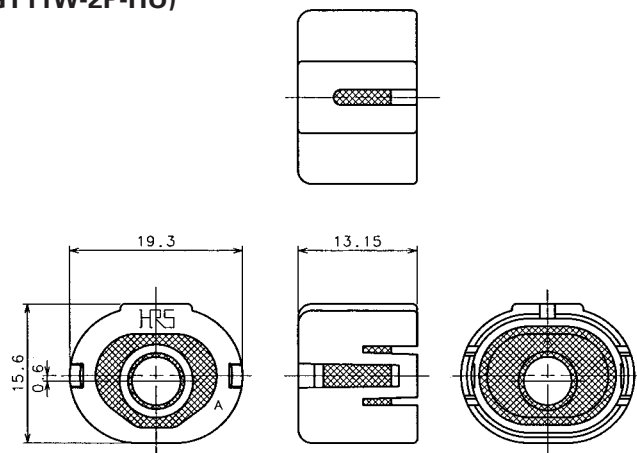

Part Number	CL No.	Applicable Cable
GT11W-6.0R	761-0025-9	PBT Silicon rubber compound

Waterproof type For Double-Conductor coaxial cable

F Connectors

● Housing

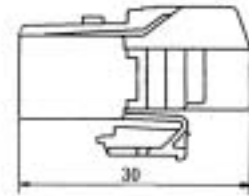
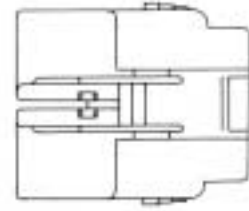
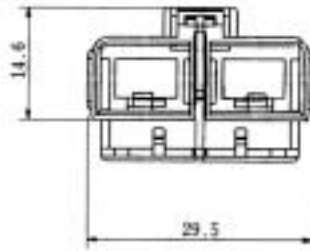

◆ Shown with inserted retainer

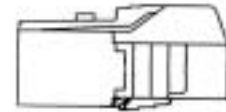

Part Number	CL No.	Material	Color
GT11K-2/2S-HU	761-0039-3	PBT	Light gray

* Mates only with GT11KN-2/2PP-HU.

M Connectors

● Housing

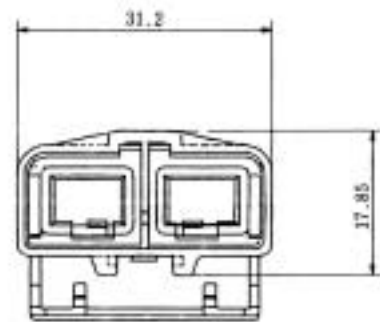
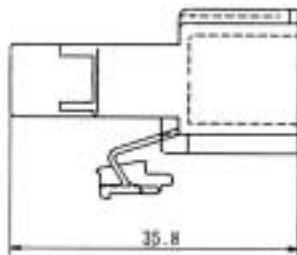
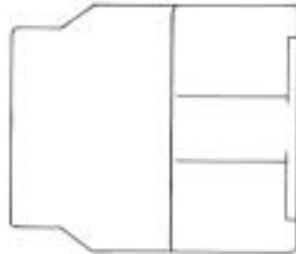

◆ Shown with inserted retainer

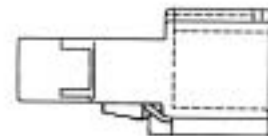

Part Number	CL No.	Material	Color
GT11KN-2/2PP-HU	761-0040-2	PBT	Light gray

◆ Termination sequence

① Strip the cable.

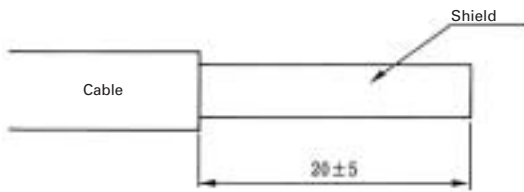

② Cut the shield and expose the wire.

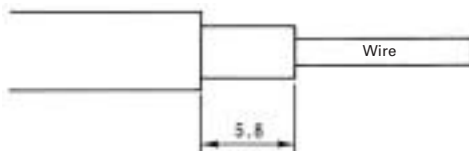

③ Cut back the shield above the sheath and wrap with conductive tape.

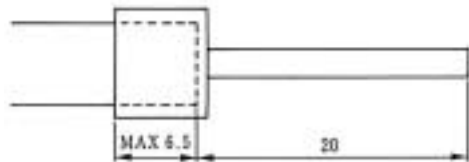

④ Strip the wire and form it.

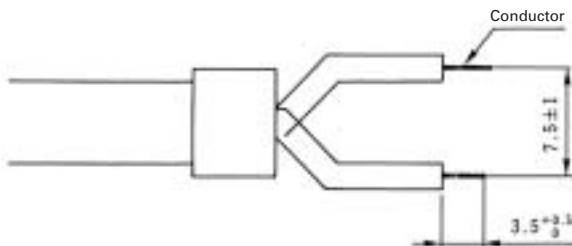

Jig used: Cable-forming strip jig
(Refer to Page 85 for detail.)

⑤ Crimp the wire to the internal terminal.

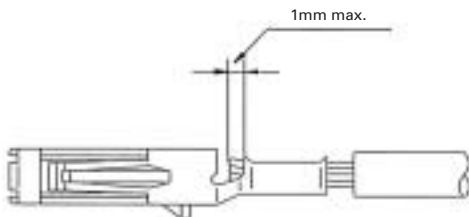

Jig used: Automatic crimping machine.
(Refer to Page 85 for detail.)

⑥ Insert the internal terminals into the Outer terminals.

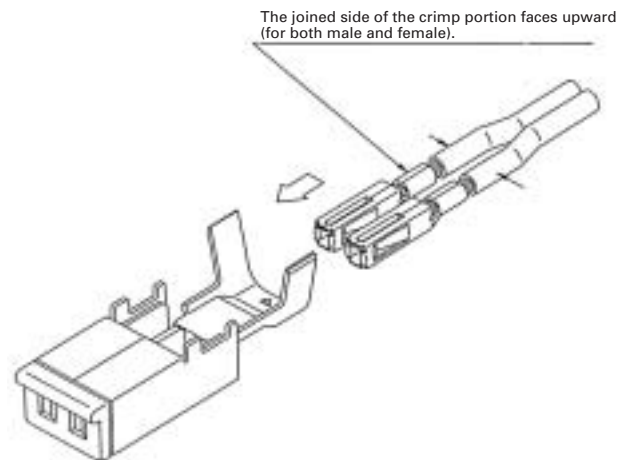

⑦ Crimp the Outer terminal.

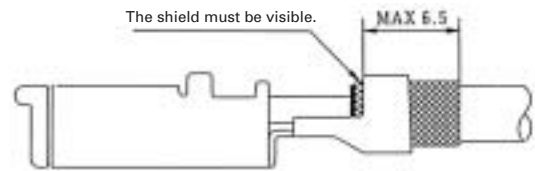

Jig used: Outside tube caulking jig.
(Refer to Page 91 for detail.)

⑧ Insert the terminal into the housing. (Please insert until the terminal is stopped by the lance.)

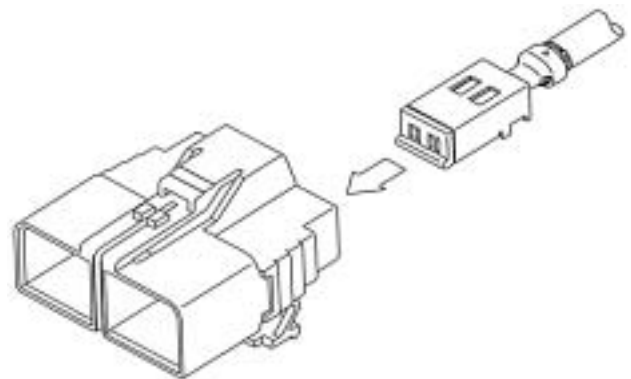

⑨ Mount the retainer to complete the task.

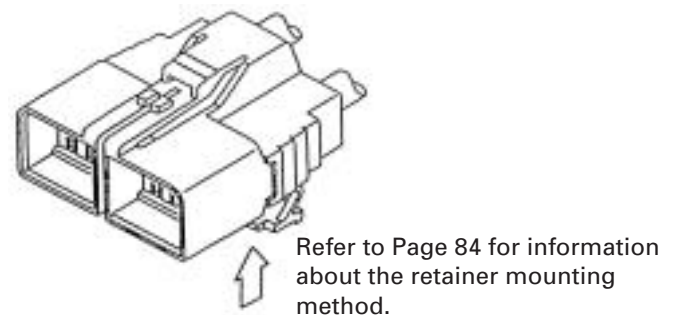

◆ Retainer Mounting Method

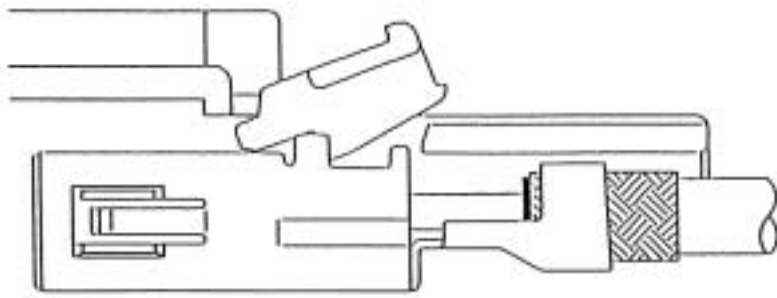
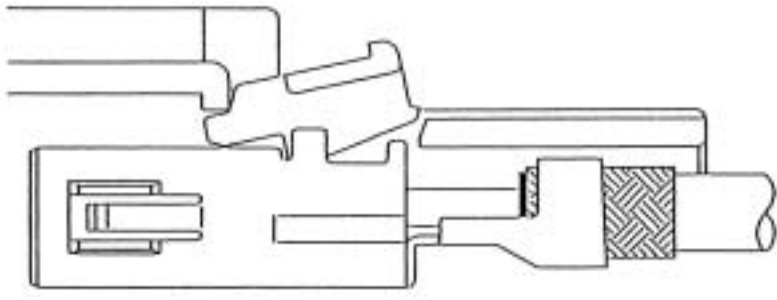
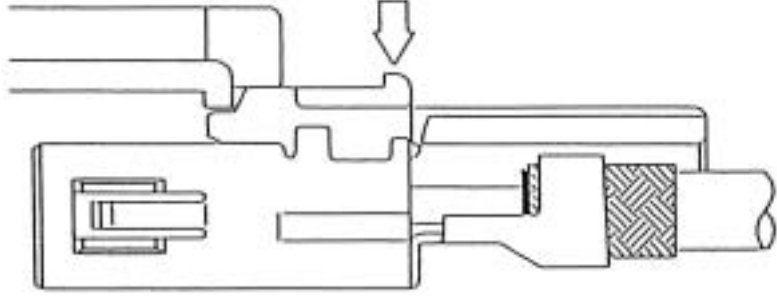
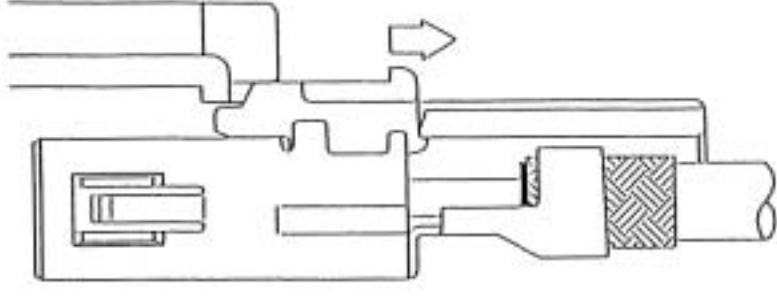
<p>a. Insert so that the terminal locking tab is inserted between the top surface of the terminal and the housing.</p>	 A cross-sectional diagram of a terminal assembly. A locking tab is being inserted from the top into a slot between the terminal and the housing. The terminal has a central pin and a side band. The housing has a corresponding slot and a locking mechanism.
<p>b. Push in while changing the angle of the retainer until the front surface comes to a stop.</p>	 A cross-sectional diagram similar to the first one, but the locking tab is now partially inserted and angled downwards. The front surface of the tab is in contact with the housing.
<p>c. Press the rear portion of the retainer and snap it into the locked position.</p>	 A cross-sectional diagram showing the locking tab fully inserted. A downward-pointing arrow indicates the rear portion of the tab is being pressed down into a locking groove.
<p>d. If locking is not complete, press the rear portion of the retainer again while pulling it backward.</p>	 A cross-sectional diagram showing the locking tab fully inserted. A downward-pointing arrow indicates the rear portion of the tab is being pressed down, and a rightward-pointing arrow indicates the tab is being pulled back.

* Check that all locations are locked.

* Check that the bands are housed in all of the receiving areas.

◆ Termination Tools

User's manuals are available. Please ask your Hirose Electric account representative.

● Cable-Forming Strip Jig (for 2-conductor cable)

Main Unit

Accessory (Electrical Box)



Part Number CT11-ST/AD

Specifications

	Capacity	Remarks
Mounting Dimensions	Approximately 400 W x 500 D x 300 H	Approximately 300 W x 250 D x 200 H
Weight	Approximately 40 kg	Approximately 5 kg
Power supply	AC100V (50/60Hz)	
Air pressure	5-6Kgf/cm	
Task time	Approximately 14 seconds	

● Automatic Crimping Machine (for 2-conductor and 8-conductor cable)



Part Number CM-105

Specifications

Item	Specification	Remarks
Capacity	1.5tons	
Stroke	30mm	
Number of strokes	200spm (50Hz)	200spm (60Hz)
Weight	75kg	
Motor	0.2kW	AC100V
Crimping speed	2000 to 4000 pcs. per day	

● Cable-Forming Strip Jig (for 2-conductor cable)

Main Unit

Accessory (Electrical Box)



Part Number CT11-CT/AD

Specifications

	Specification	Remarks
Mounting Dimensions	Approximately 300 W x 400 D x 300 H	Approximately 300 W x 250 D x 200 H
Weight	Approximately 25 kg	Approximately 5 kg
Power supply	AC100V (50/60Hz)	
Air pressure	5-6Kgf/cm	

* Crimp height setting tables are available for each cable type. Please contact your nearest Hirose Electric account representative.
Different cables will require different crimp height settings.

For 8-Conductor coaxial shielded cable

F Connectors

● Inner Terminal

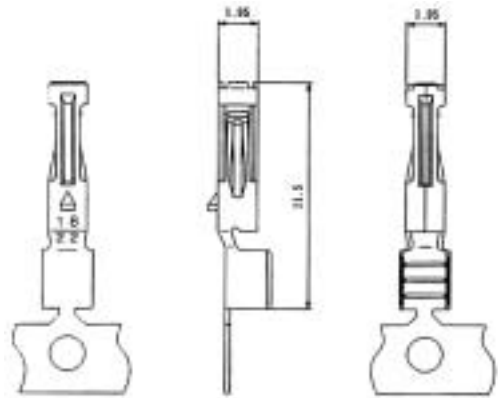

Part Number	CL No.	Conductor Size (AWG)	Material	Finish
GT11-1822SCF	761-0004-9	#24 to 28	Phosphor bronze	Tin plating
GT11-2428SCF	761-0020-5	#24 to 28	Phosphor bronze	Tin plating

● Insulator

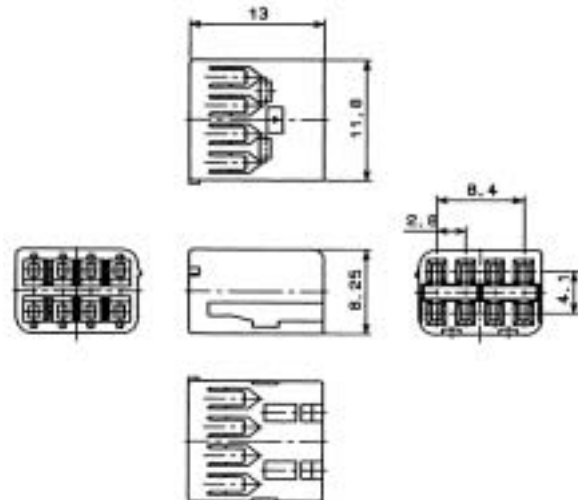

Part Number	CL No.	Material
GT11-8DS-2.8C	761-0014-2	PBT

● Outer terminals

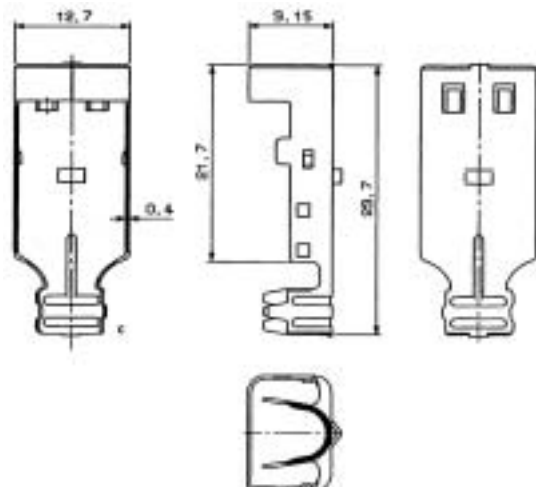

Part Number	CL No.	Material	Finish
GT11-8DS-5C	761-0015-5	Brass	Phosphor bronze

● Shield Plate

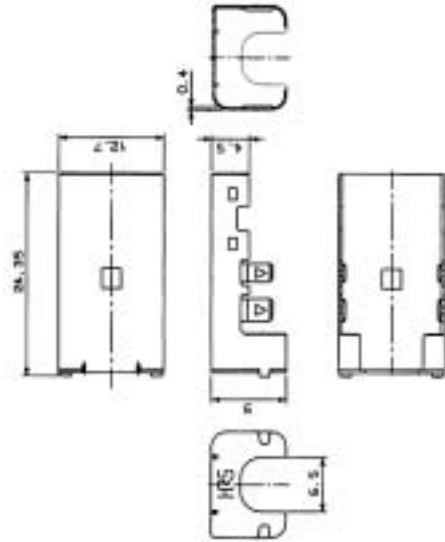

Part Number	CL No.	Material	Finish
GT11-8DS-SB	761-0016-8	Brass	Tin plating

● Housing

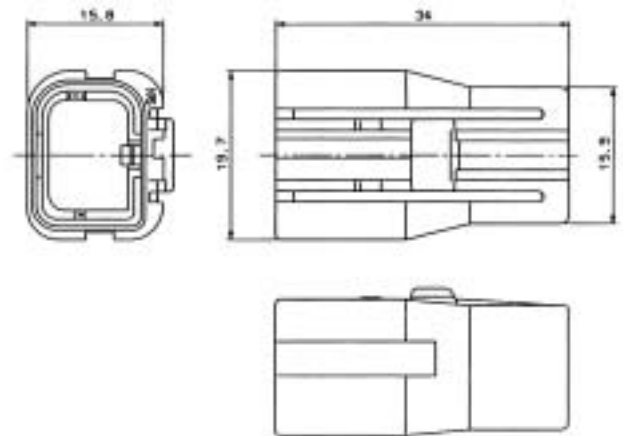

Part Number	CL No.	Material
GT11-8DS-HU	761-0017-0	PBT

● Retainer (used with GT11-8DS-HU)

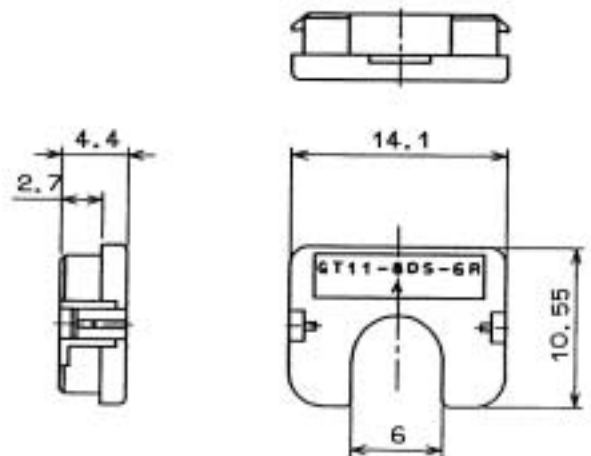

Part Number	CL No.	Material
GT11-8DS-6R	761-0018-3	PBT

M Connectors

● Inner Terminals

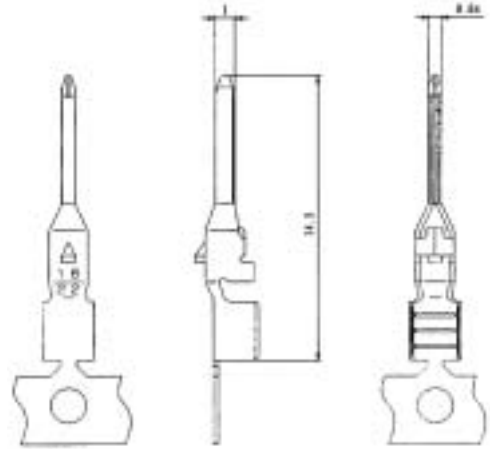

Part Number	CL No.	Conductor Size (AWG)	Material	Finish
GT11-1822PCF	761-0003-6	#18 to 22	Phosphor bronze	Tin plating
GT11-2428PCF	761-0019-6	#24 to 28	Phosphor bronze	Tin plating

● Insulator

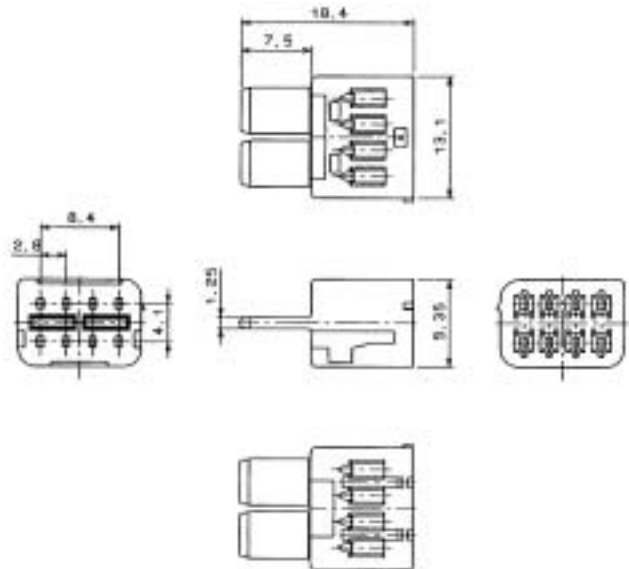

Part Number	CL No.	Material
GT11-8DP-2.8C	761-0009-2	PBT

● Outer terminals

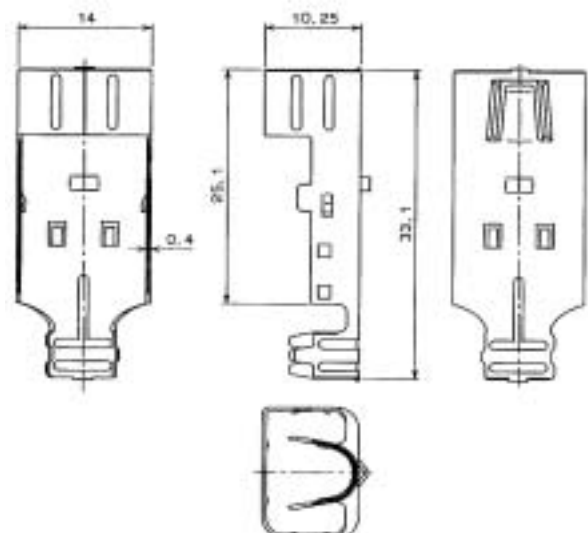

Part Number	CL No.	Material	Finish
GT11-8DP-5C	761-0010-1	Brass	Phosphor bronze

● Shield Plate

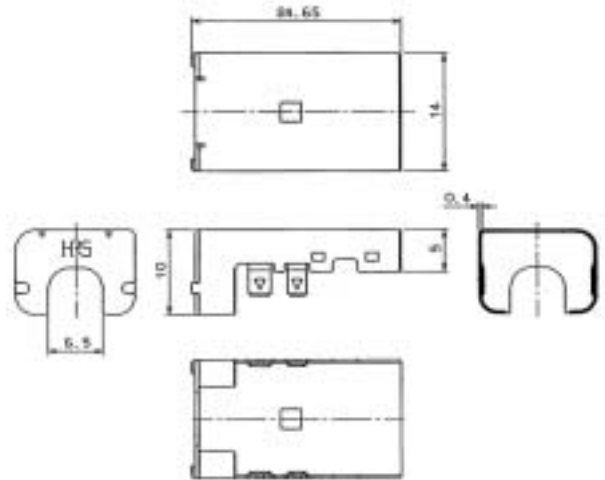

Part Number	CL No.	Material	Finish
GT11-8DP-SB	761-0011-4	Brass	Phosphor bronze

● Housing

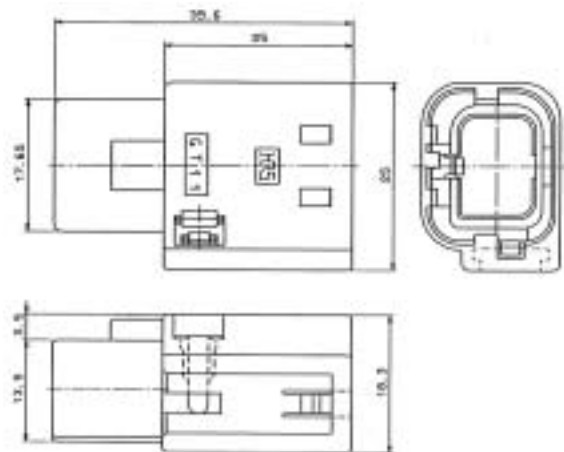

Part Number	CL No.	Material
GT11-8DP-HU	761-0012-7	PBT

● Retainer (Used with GT11-8DS-HU)

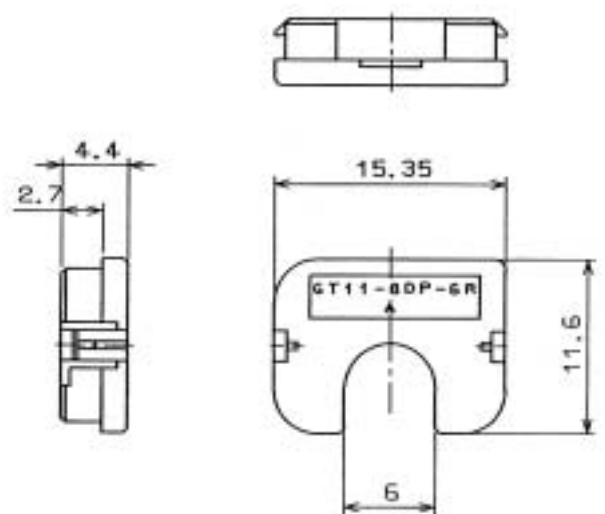

Part Number	CL No.	Material
GT11-8DP-6R	761-0013-0	PBT

* Reserved for product expansion

● Printed Circuit Board Type

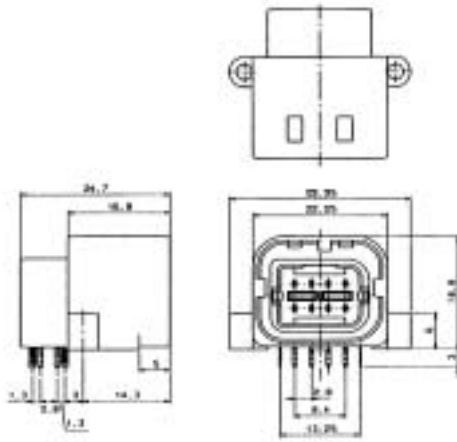

◆ Recommended Board Mounting Pattern

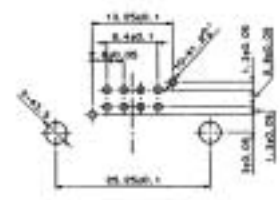

◆ Fully mated connector assemblies

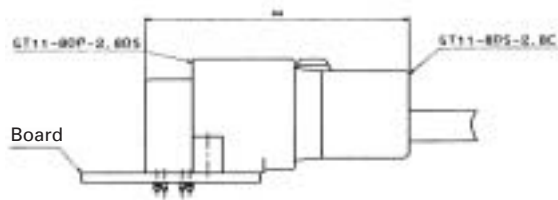

Part Number	CL No.	Item	Material	Finish
GT11-8DP-2.8DS	761-0021-8	Housing	PBT	
		Outer Terminal	Phosphor bronze	Tin plating
		Insulator	PBT	
		Terminal	Brass	Tin plating

◆ Termination sequence

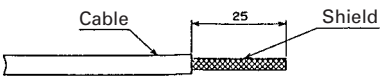
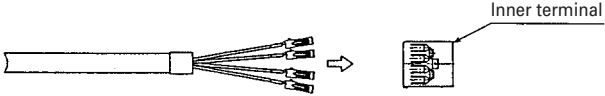
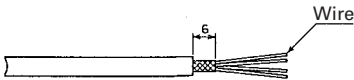
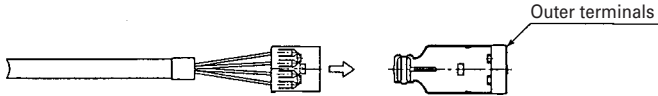
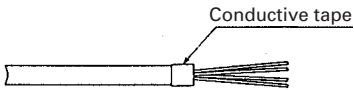
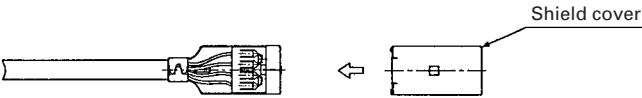
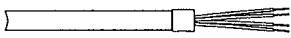
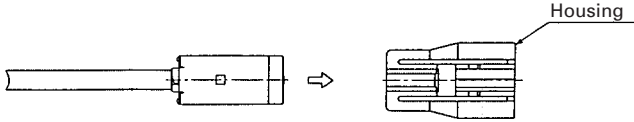
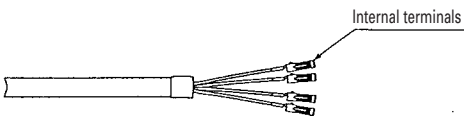
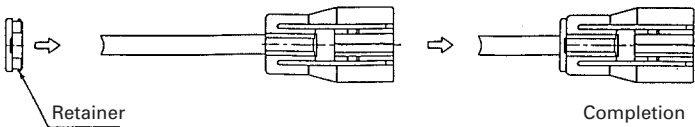
<p>① Strip the Cable.</p>  <p>The diagram shows a cross-section of a cable. A section of length 25 is marked, showing the outer jacket and the shield being stripped back. Labels include 'Cable', '25', and 'Shield'.</p>	<p>⑥ Insert the inner terminals into the insulated case.</p>  <p>The diagram shows a bundle of wires with terminals being inserted into a rectangular insulated case. Labels include 'Inner terminal'.</p>
<p>② Cut the shield and expose the wire.</p>  <p>The diagram shows the shield being cut back, exposing the individual wires. A length of 6 is marked for the exposed wires. Labels include 'Wire' and '6'.</p>	<p>⑦ Insert what was made in Step ⑥ into the Outer terminals.</p>  <p>The diagram shows the assembly from Step 6 being inserted into a component with 'Outer terminals'.</p>
<p>③ Cut back the shield above the sheath and wrap with conductive tape.</p>  <p>The diagram shows the shield being wrapped with 'Conductive tape'.</p>	<p>⑧ Insert the caulking shield cover onto the Outer terminals.</p>  <p>The diagram shows a 'Shield cover' being inserted onto the assembly.</p>
<p>④ Strip the wire.</p>  <p>The diagram shows the individual wires being stripped.</p>	<p>⑨ Insert what was made in Step ⑧ into the housing.</p>  <p>The diagram shows the assembly from Step 8 being inserted into a 'Housing'.</p>
<p>⑤ Crimp the internal terminals.</p>  <p>The diagram shows 'Internal terminals' being crimped onto the wires.</p>	<p>⑩ Insert the retainer.</p>  <p>The diagram shows a 'Retainer' being inserted into the assembly, leading to 'Completion'.</p>

◆ Termination Tools

User's manuals are available. Please ask your Hirose Electric account representative.

● Cable-Forming Strip Jig (for 2-conductor cable)

Main Unit Accessory (Electrical Box)



Part Number CT11-ST/AD

Specifications

	Capacity	Remarks
Mounting Dimensions	Approximately 400 W x 500 D x 300 H	Approximately 300 W x 250 D x 200 H
Weight	Approximately 40 kg	Approximately 5 kg
Power supply	AC100V (50/60Hz)	
Air pressure	5-6Kgf/cm	
Task time	Approximately 14 seconds	

● Automatic Crimping Machine (for 2-conductor and 8-conductor cable)



Part Number CM-105

Specifications

Item	Specification	Remarks
Capacity	1.5Ton	
Stroke	30mm	
Number of strokes	200spm (50Hz)	240spm (60Hz)
Weight	75kg	
Motor	0.2kW	AC100V
Crimping speed	2000 to 4000 pcs. per day	

● Cable-Forming Strip Jig (for 2-conductor cable)

Main Unit Accessory (Electrical Box) Specifications



Part Number CT11-CT/AD

	Specification	Remarks
Mounting Dimensions	Approximately 300 W x 400 D x 300 H	Approximately 300 W x 250 D x 200 H
Weight	Approximately 25 kg	Approximately 5 kg
Power supply	AC100V (50/60Hz)	
Air pressure	5-6Kgf/cm	

* Crimp height setting tables are available for each cable type. Please contact your nearest Hirose Electric account representative.
Different cables will require different crimp height settings.

● Outer terminal Caulking Jig (for 8-conductor cable)

Hand Press



Part Number GT11-8S/P-HP

Данный компонент на территории Российской Федерации

Вы можете приобрести в компании MosChip.

Для оперативного оформления запроса Вам необходимо перейти по данной ссылке:

<http://moschip.ru/get-element>

Вы можете разместить у нас заказ для любого Вашего проекта, будь то серийное производство или разработка единичного прибора.

В нашем ассортименте представлены ведущие мировые производители активных и пассивных электронных компонентов.

Нашей специализацией является поставка электронной компонентной базы двойного назначения, продукции таких производителей как XILINX, Intel (ex.ALTERA), Vicor, Microchip, Texas Instruments, Analog Devices, Mini-Circuits, Amphenol, Glenair.

Сотрудничество с глобальными дистрибьюторами электронных компонентов, предоставляет возможность заказывать и получать с международных складов практически любой перечень компонентов в оптимальные для Вас сроки.

На всех этапах разработки и производства наши партнеры могут получить квалифицированную поддержку опытных инженеров.

Система менеджмента качества компании отвечает требованиям в соответствии с ГОСТ Р ИСО 9001, ГОСТ РВ 0015-002 и ЭС РД 009

Офис по работе с юридическими лицами:

105318, г.Москва, ул.Щербаковская д.3, офис 1107, 1118, ДЦ «Щербаковский»

Телефон: +7 495 668-12-70 (многоканальный)

Факс: +7 495 668-12-70 (доб.304)

E-mail: info@moschip.ru

Skype отдела продаж:

moschip.ru

moschip.ru_4

moschip.ru_6

moschip.ru_9