

Copyright FCI.  
FCI

spec ref	-	dr	Liu Jenson	2013/09/17	projection	MM	size	A2	scale	3:1	
tolerance std	ASME Y14.5	eng	Liu Jenson	2014/04/22			ecn no	ELX-DG-17541-1			
TOLERANCES UNLESS OTHERWISE SPECIFIED		chr	Jon Qin	2014/04/25			rel level	Released			
surface	ASME Y14.5	appr	Collins Lu	2014/04/25			product family	HPCE			
linear	0.X ±0.3	FCI		title	R/A HEADER 16P (HP) ASM			dwg no	10127285		
	0.XX ±0.10	www.fci.com		HPCE CTB R/A-HEADER	Product - Customer Drw			rev	B		
angular	0° ±2°	cat. no.		-			sheet 1 of 3				

PDS: Rev :B

STATUS:Released

Printed: Apr 25, 2014

CONTACT TYPE	TOP LAYER DESCRIPTION	TABLE 1 (HPCE / SOLDER TAILS) PLATED THROUGH-HOLE REQUIREMENTS				
		DRILLED HOLE DIAMETER	COPPER THICKNESS	TIN-LEAD THICKNESS	TIN THICKNESS	FINISHED HOLE DIAMETER
POWER	TIN-LEAD	1.10-1.16 (1.15 DRILL)	0.025 - 0.050	0.005 - 0.015	--	0.94 - 1.10
	IMMERSION TIN	1.10-1.16 (1.15 DRILL)	0.025 - 0.050	--	0.9 - 1.5um	0.94 - 1.10
	COPPER (SEE NOTE 8)	1.10-1.16 (1.15 DRILL)	0.025 - 0.050	--	--	0.94 - 1.10

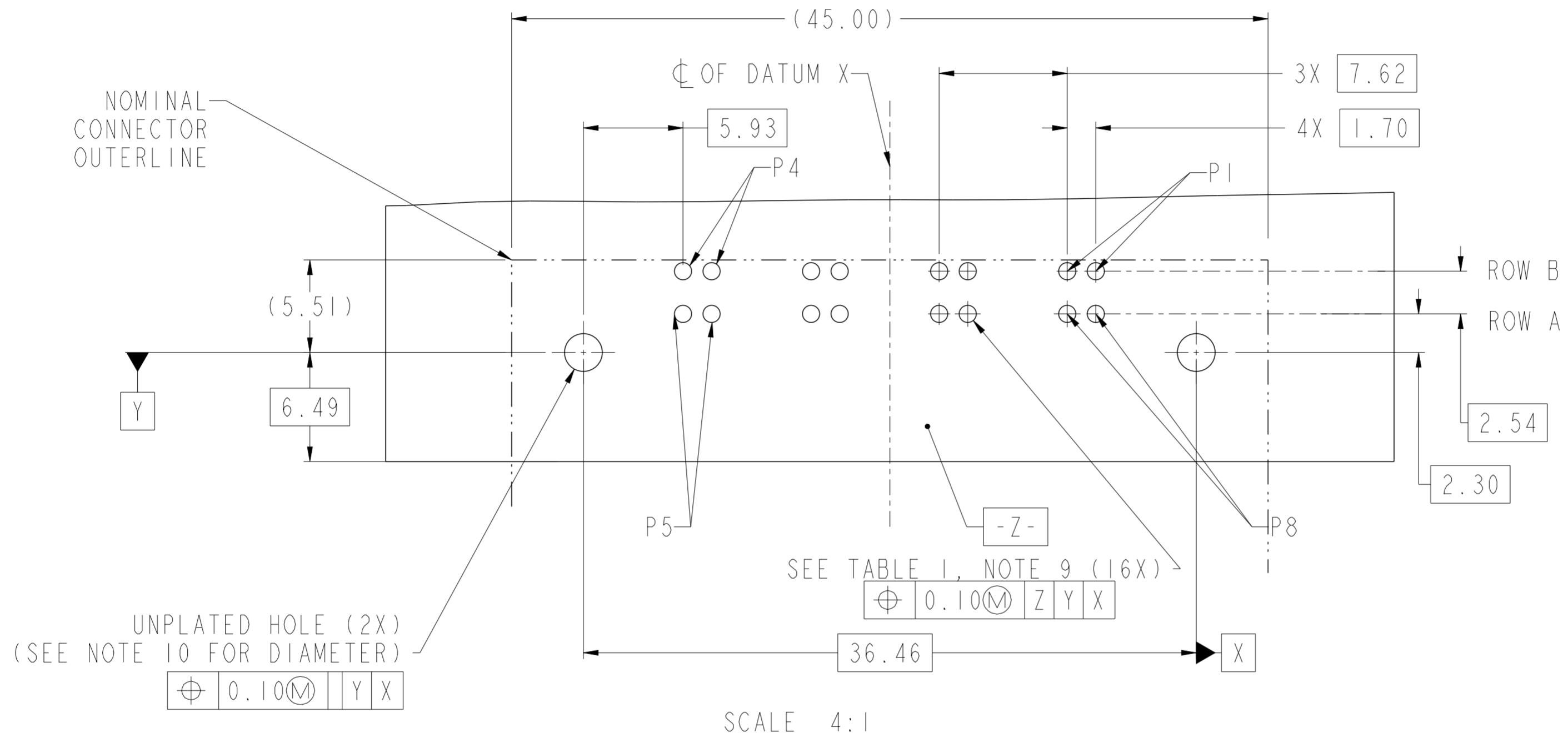

RECOMMENDED PCB LAYOUT  
VIEW FROM CONNECTOR SIDE

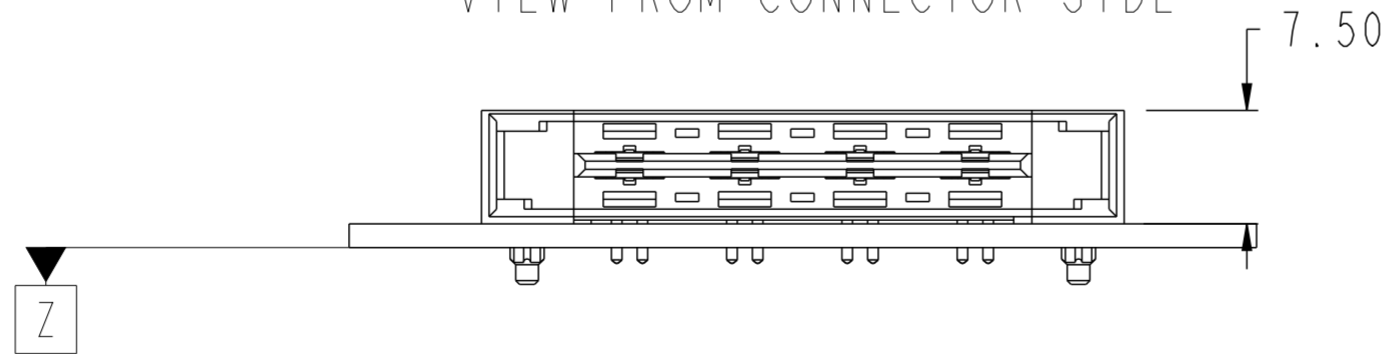

spec ref	-	dr	Liu Jenson	2013/09/17	projection	MM	size	A2	scale	3:1	
tolerance std	ASME Y14.5	eng	Liu Jenson	2014/04/22			ecn no	ELX-DG-17541-1	rel level	Released	
TOLERANCES UNLESS OTHERWISE SPECIFIED		chr	Jon Qin	2014/04/25							
		appr	Collins Lu	2014/04/25							
surface	ASME Y14.5	linear	0.X	±0.3	0.XX	±0.10	0.XXX	±0.050	angular	0°	±2°
					<b>FCI</b>		title R/A HEADER 16P (HP) ASM HPCE CTB R/A-HEADER		cat. no. -		
		www.fci.com			Product - Customer Drw		sheet 2 of 3		rev B		

PRODUCT PART NUMBER

10127285-□□□□□ LF

BASE PART NUMBER

CONTACT AREA PLATING  
 UNDERPLATED 50u"(1.27um) MIN. NICKEL  
 1: 100u"(2.5um) MIN. Ag  
 2: 30u"(0.760um) MIN. GXT

FIRST MATE LAST BREAK PIN POSITION  
 000: ALL PINS ARE LONG PINS SEE TABLE

DIM "A", TAIL LENGTH  
 1: 2.60±0.25mm (PCB THK 1.57±0.13mm)  
 2: 3.25±0.25mm (PCB THK 2.36±0.13mm)

NOTES:

1. CONNECTOR MATERIALS:  
 HOUSING:HIGH TEMPERATURE THERMAL PLASTIC, BLACK UL 94V-0 COMPLIANT  
 CONTACTS:HIGH PERFORMANCE COPPER ALLOY.

2. CONTACT FINISH REF. GS-12-1031 SECTION 5.2

3. PRODUCT SPECIFICATION: GS-12-1031

4. APPLICATION SPECIFICATION: GS-20-0369

5. PRODUCT MARKING (FCI PART NUMBER & DATE CODE) ON HOUSING IN AREA SHOWN.

6. PACKAGING MEETS FCI SPECIFICATION GS-14-2272 

7. HOUSING COMPONENT WILL WITHSTAND EXPOSURE TO 260°C PEAK TEMPERATURE FOR 60 SECONDS IN A CONVECTION, INFRA-RED, OR VAPOR PHASE REFLOW OVEN.

8. COPPER PLATING THICKNESS IN CENTER OF VIA-HOLE CAN BE NO MORE THAN 0.003 LESS THAN OTHER AREAS.



9. ALL HOLE SIZES ARE FINISHED HOLE SIZES.

10. MOUNTING HOLES ARE UNPLATED  
 Ø 2.25±0.05 FOR SOLDER TAILS

000	END MODULE	POWER CONTACT					END MODULE
		4	3	2	1	ROW A	
		P1	P1	P1	P1	ROW A	
		P3	P3	P3	P3	ROW B	

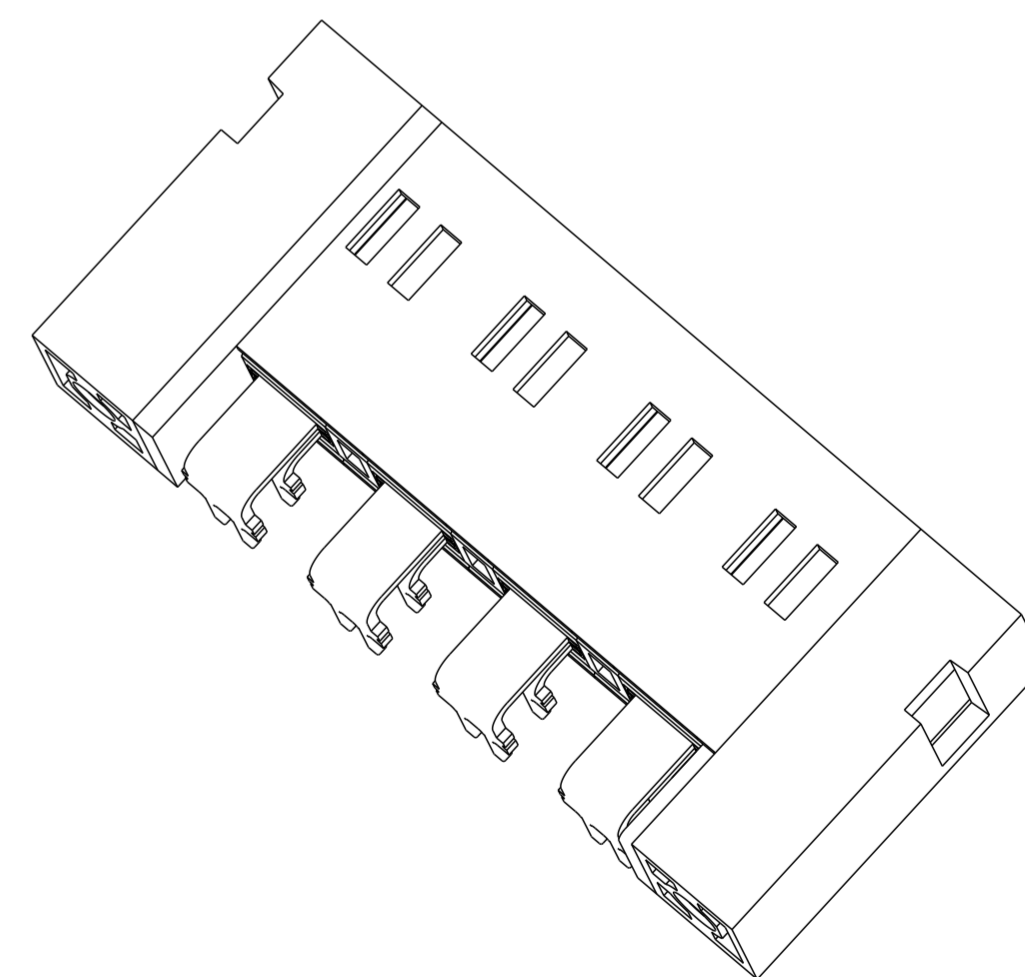
POWER CONTACT	ROW#	P#	DIM "C"±0.25	DIM "A"±0.25
ROW A		P1	8.86	2.60
		P2	7.59	2.60
		P5	8.86	3.25
		P6	7.59	3.25
ROW B		P3	8.86	2.60
		P4	7.59	2.60
		P7	8.86	3.25
		P8	7.59	3.25

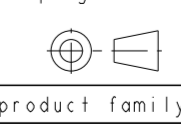

spec ref	-	dr	Liu Jenson	2013/09/17	projection	MM	size	A2	scale	3:1
tolerance std	ASME Y14.5	eng	Liu Jenson	2014/04/22		←	ecn no	ELX-DG-17541-1		
TOLERANCES UNLESS OTHERWISE SPECIFIED		chr	Jon Qin	2014/04/25			rel level	Released		
surface	✓	appr	Collins Lu	2014/04/25			product family	HPCE		
linear	0.X ±0.3 0.XX ±0.10 0.XXX ±0.050			title	R/A HEADER 16P (HP) ASM		dwg no	10127285		
angular	0° ±2°	www.fci.com		cat. no.	-		Product - Customer Drw	sheet 3 of 3		

## Данный компонент на территории Российской Федерации

### Вы можете приобрести в компании MosChip.

Для оперативного оформления запроса Вам необходимо перейти по данной ссылке:

<http://moschip.ru/get-element>

Вы можете разместить у нас заказ для любого Вашего проекта, будь то серийное производство или разработка единичного прибора.

В нашем ассортименте представлены ведущие мировые производители активных и пассивных электронных компонентов.

Нашей специализацией является поставка электронной компонентной базы двойного назначения, продукции таких производителей как XILINX, Intel (ex.ALTERA), Vicor, Microchip, Texas Instruments, Analog Devices, Mini-Circuits, Amphenol, Glenair.

Сотрудничество с глобальными дистрибьюторами электронных компонентов, предоставляет возможность заказывать и получать с международных складов практически любой перечень компонентов в оптимальные для Вас сроки.

На всех этапах разработки и производства наши партнеры могут получить квалифицированную поддержку опытных инженеров.

Система менеджмента качества компании отвечает требованиям в соответствии с ГОСТ Р ИСО 9001, ГОСТ РВ 0015-002 и ЭС РД 009

### Офис по работе с юридическими лицами:

105318, г.Москва, ул.Щербаковская д.3, офис 1107, 1118, ДЦ «Щербаковский»

Телефон: +7 495 668-12-70 (многоканальный)

Факс: +7 495 668-12-70 (доб.304)

E-mail: [info@moschip.ru](mailto:info@moschip.ru)

Skype отдела продаж:

moschip.ru

moschip.ru\_4

moschip.ru\_6

moschip.ru\_9