



Product Specification for Reference Only

Issued Date: 22 October, 2013 _____

Rev. : _____

Part Description: Fresnel Lens _____

MURATA Part No.: IML-0688 _____

The product specification in this sheet is for reference only.
The contents of this specification is subject to change.

You are requested to receive the latest specification and to return one copy of the specification to us with your receipt signature before going into mass production.

Product engineering section
Sensor module department
Circuit module products division
Murata MFG. Co.,Ltd.

MURATA MANUFACTURING CO.,LTD.

1. Scope

This product specification is applied to fresnel lens IML-0688 used for Pyroelectric infrared sensor IRA-S210ST01 to detect infrared ray. Please contact us when using this product for any other applications than described in the above.

2. Murata Part Number

IML-0688

3. Outline Drawing and Dimensions

See Figure 1

4. Material etc.

4-1 Material

High density polyethylene

4-2 Refractive Index

1.51

4-3 Transmittance

See Figure 4

4-4 Color

IML-0688 : Natural White

IML-0688G : Gray

IML-0688W : White

5. Lens

5-1 Field of View

See Figure 2 and Figure 3

6. Operating Temperature

-25 to 55°C

7. Storage Temperature

-30 to 80°C

8. Reliability

After each one of the test, No transformation, No crack.

8-1 High temperature

85°C for 500hours

8-2 Low temperature

-30°C for 500hours

8-3 Humidity

60°C, 95%RH for 500hours

8-4 Heat cycle

20 times of the following cycle

-25°C, 30min.⇒ Room temp. 30min.⇒ 55°C, 30min.⇒ Room temp.

9. ⚠ Caution

9-1 Limitation of Applications

Please contact us before using our for the applications listed below which require especially high reliability for the prevention of defects which might directly cause damage to the third party's life, body or property.

1. Aircraft equipment
2. Aerospace equipment
3. Undersea equipment
4. Power plant control equipment
5. Medical equipment
6. Transportation equipment (vehicles, trans, ships, etc.)
7. Traffic signal equipment
8. Disaster prevention / crime prevention equipment
9. Data-processing equipment
10. Application of similar complexity and/or reliability requirement to the applications listed in the above

9-2 Fail-safe

Be sure to provide an appropriate fail-safe function on your product to prevent a second damage that may be caused by the abnormal function or the failure of our product.

10. Caution in use

10-1 Notice in design

- 1) Please set the direction of the tab of fresnel lens to the tab of sensor.
- 2) To bring pyro-Element into the focus of fresnel lens, Please push the sensor until the step inside the fresnel lens.
- 3) Please add any mechanism for preventing dislocation or for preventing coming off from the sensor because of transition fit between sensor and fresnel lens
- 4) Please avoid using the fresnel lens in the following conditions because it may cause failure or malfunction ;
 - a) in such a fluid as water, alcohol etc. corrosive gas (SO₂, Cl₂, NO_x etc.) or sea breeze.
 - b) in high humidity.
 - c) in a place exposed directly to sun light or headlight of automobile.
 - d) in a place exposed directly to blow from air-conditioner or heater.
 - e) in such a place where infrared ray is shaded.
 - f) in any other place similar to the above (a) through (e).

10-2 Notice in handling and storage

- 1) Optical filter of sensor should not be scratched or soiled.
- 2) Strong shock should be avoided.
- 3) High temperature, high humidity, fluid as water or alcohol etc., corrosive gas (SO₂, Cl₂, NO_x etc.) and sea breeze should be avoided.
- 4) Use the products within 6 months after receiving.

11. Note

- 1) Please make sure that your product has been evaluated in view of your specifications with our product being mounted to your product.
- 2) You are requested not to use our product deviating from the agreed specifications.
- 3) We consider it not to appropriate to include any terms and conditions with regard to the business transaction in the product specifications, drawings or other technical documents. Therefore, if your technical documents as above include such terms and conditions such as warranty clause, product liability clause, or intellectual property infringement liability clause, they will be deemed to be invalid.

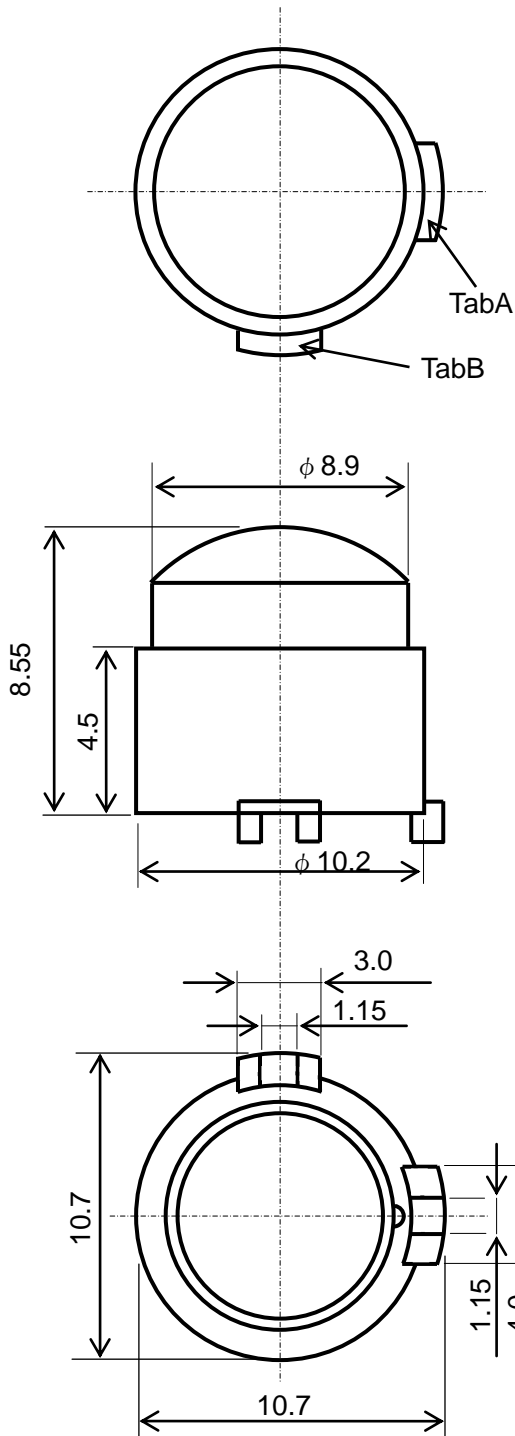

Unit : mm
 General tolerance : ± 0.2

- ※Please set the direction of the tab on the fresnel lens to the tab on the sensor.
- ※To bring pyro-Element into the focus of fresnel lens, Please push the sensor until the step inside the fresnel lens.
- ※Please design the housing that the sensor does not receive infrared ray through the area shown as diagram in Figure A.
- ※Please design housing and set of sensor and lens to prevent from dislocation and coming off .

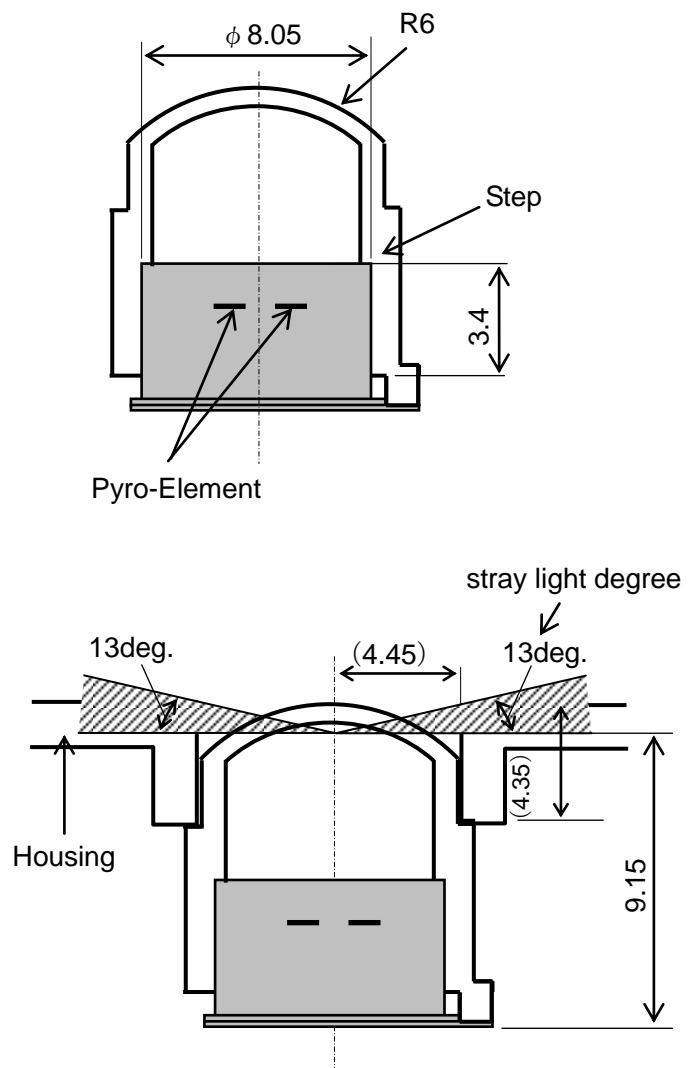
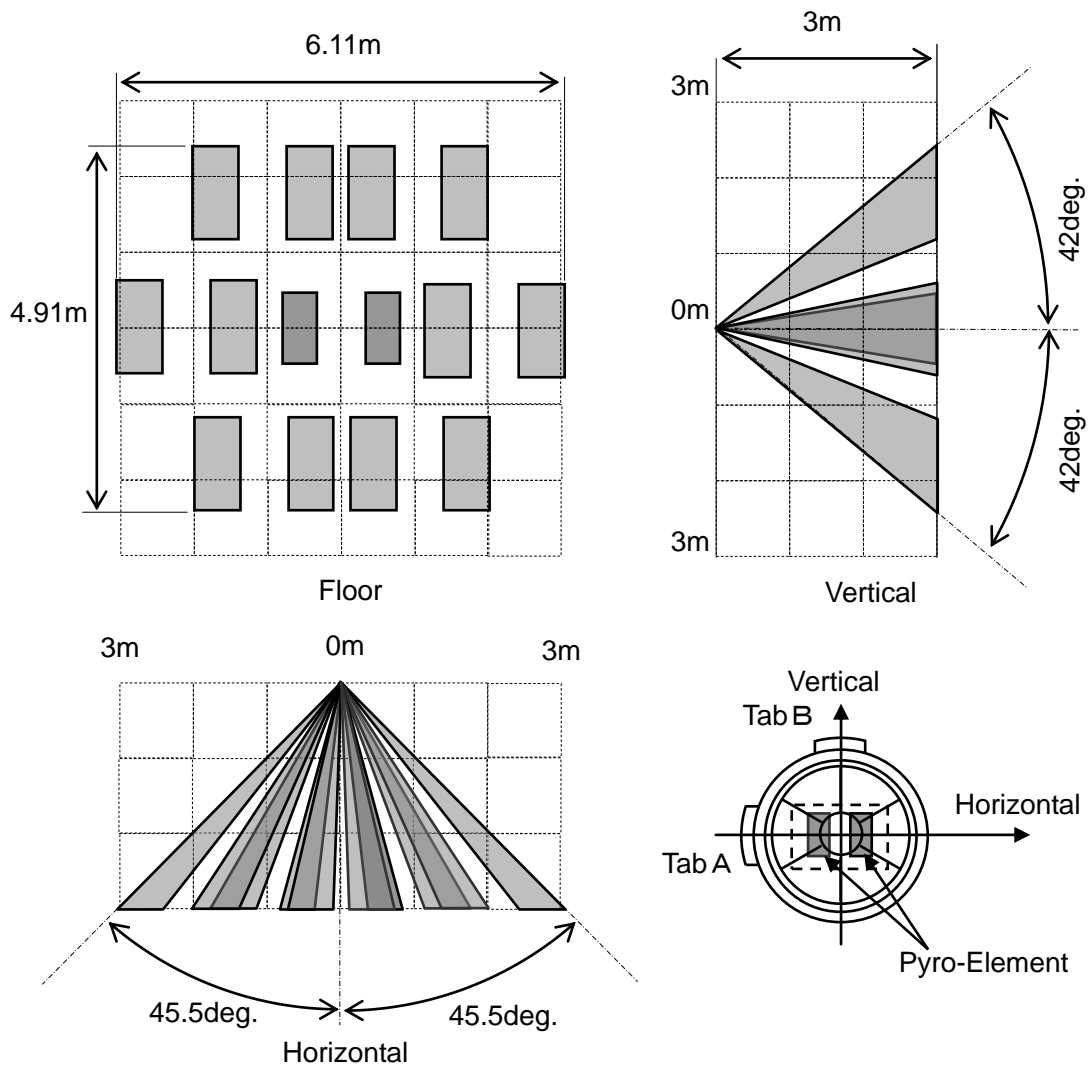

Figure A
 An example of a design of the housing

Figure 1



※Assembled with Murata sensor IRA-S210 series

Figure 2

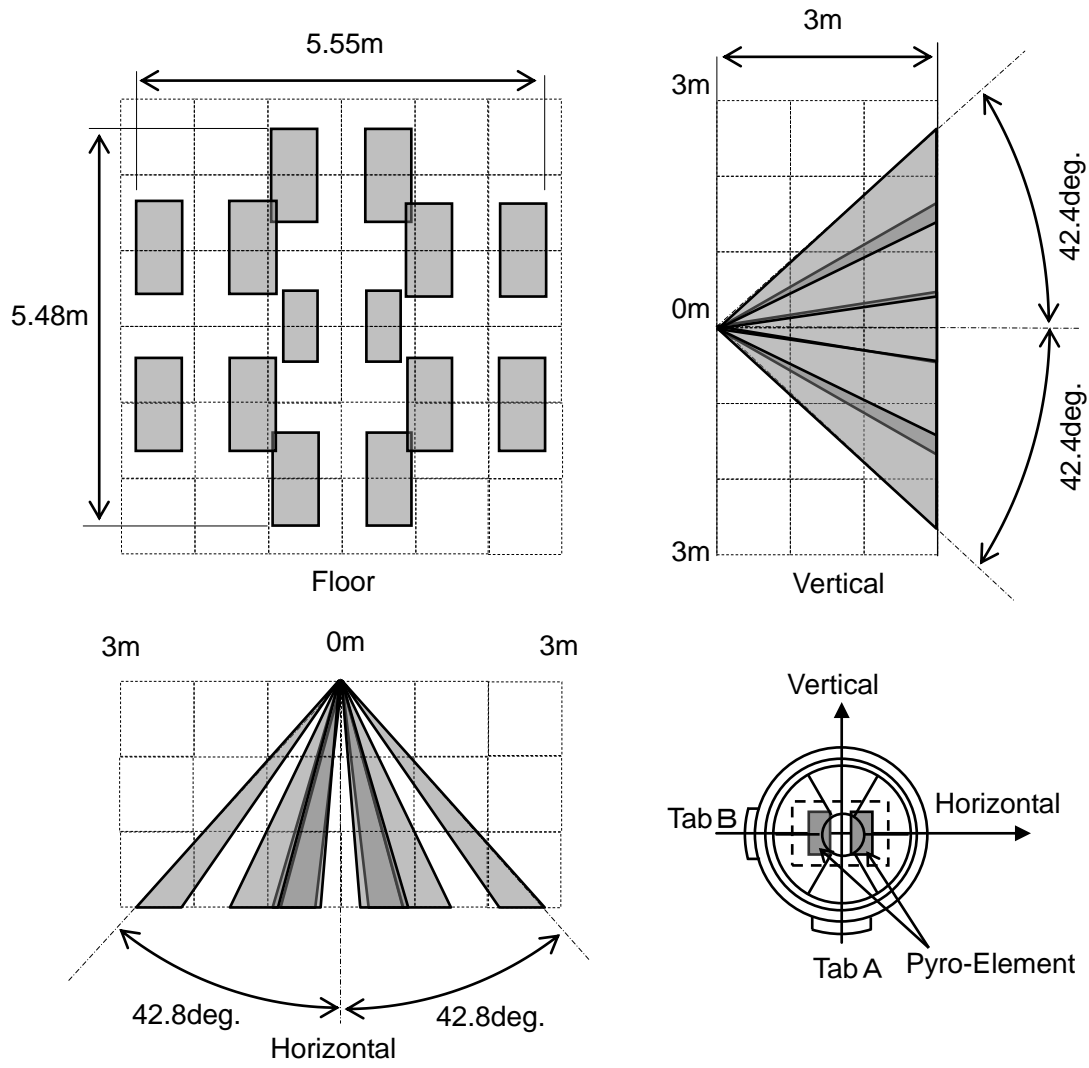

※Assembled with Murata sensor IRA-S210 series

Figure 3

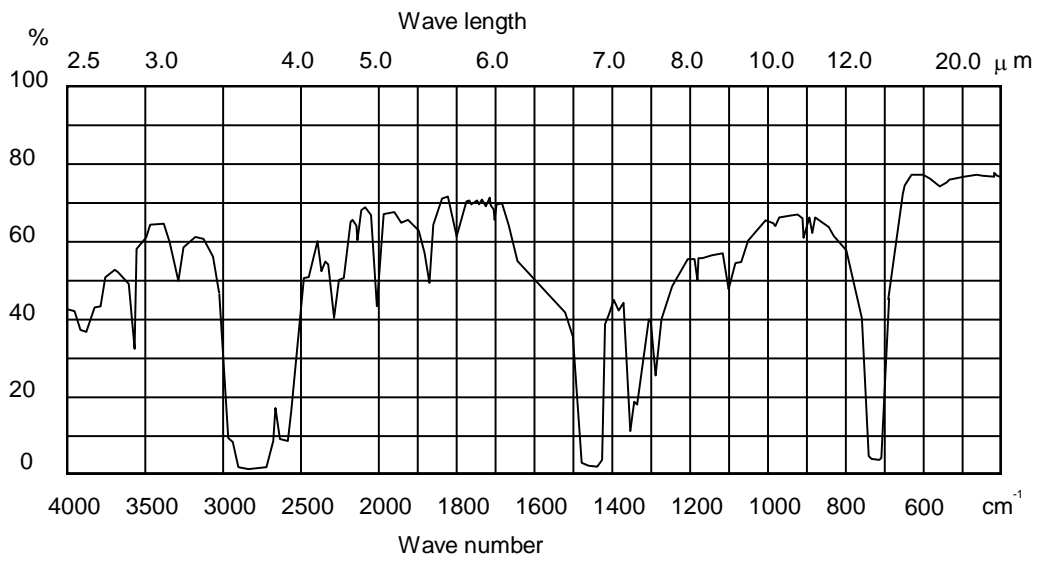

Figure 4. Transmittance

Данный компонент на территории Российской Федерации

Вы можете приобрести в компании MosChip.

Для оперативного оформления запроса Вам необходимо перейти по данной ссылке:

<http://moschip.ru/get-element>

Вы можете разместить у нас заказ для любого Вашего проекта, будь то серийное производство или разработка единичного прибора.

В нашем ассортименте представлены ведущие мировые производители активных и пассивных электронных компонентов.

Нашей специализацией является поставка электронной компонентной базы двойного назначения, продукции таких производителей как XILINX, Intel (ex.ALTERA), Vicor, Microchip, Texas Instruments, Analog Devices, Mini-Circuits, Amphenol, Glenair.

Сотрудничество с глобальными дистрибьюторами электронных компонентов, предоставляет возможность заказывать и получать с международных складов практически любой перечень компонентов в оптимальные для Вас сроки.

На всех этапах разработки и производства наши партнеры могут получить квалифицированную поддержку опытных инженеров.

Система менеджмента качества компании отвечает требованиям в соответствии с ГОСТ Р ИСО 9001, ГОСТ РВ 0015-002 и ЭС РД 009

Офис по работе с юридическими лицами:

105318, г.Москва, ул.Щербаковская д.3, офис 1107, 1118, ДЦ «Щербаковский»

Телефон: +7 495 668-12-70 (многоканальный)

Факс: +7 495 668-12-70 (доб.304)

E-mail: info@moschip.ru

Skype отдела продаж:

moschip.ru

moschip.ru_4

moschip.ru_6

moschip.ru_9