

HEDG-9000 Series

Codewheel for use with Avago Technologies
Ultra-precision 17-Bit Absolute Single Turn Encoder
Encoder Modules AEAT-9000 series



Data Sheet



Description

Avago Technologies offers a codewheel designed specifically for use with the AEAT-9000 series encoder modules. The HEDG-9000 Series codewheel is suitable for many environments, applications, and budgets. Made from glass the HEDG-9000 codewheel has a resolution of 2048 CPR and an optical radius of 17.5 mm.

Note: Avago Technologies encoders are not recommended for use in safety critical applications, e.g., ABS braking systems, power steering, life support systems and critical care medical equipment. Avago's products and software are not specifically designed, manufactured or authorized for sale as parts, components or assemblies for the planning, construction, maintenance or direct operation of a nuclear facility or for use in medical devices or applications. Customer is solely responsible, and waives all rights to make claims against Avago or its suppliers, for all loss, damage, expense or liability in connection with such use. Please contact sales representative if more clarification is needed.

Features

- Codewheel in Glass.
- Cost Effective
- Resolutions of 2048 CPR
- For Use with AEAT-9000 Series Encoders
- Lead Free

Applications

Typical applications include

- Rotary applications up to 17 bits/360° absolute position
- Integration into servo motors
- Industrial and maritime valve control
- High precision test and measurement machines
- Industrial and factory automation equipments
- Textile, woodworking & packaging machineries
- Nacelle & blades control in wind turbine

Absolute Maximum Ratings

Parameter	Symbol	Min.	Typical	Max.	Units
Storage Temperature	T _S	-40		115	°C
Operating Temperature	T _A	-40		115	°C
Velocity				15000	RPM
Shaft Axial Play		-0.05		0.05	mm
Shaft Eccentricity(inclusive module radial play)				0.05	mm TIR

Recommended Operating Conditions

Description	Min.	Typical	Max.	Units
Maximum Count Frequency			500	kHz
Shaft Axial Play	-0.05		0.05	mm
Shaft Eccentricity(inclusive module radial play)			0.05	mm TIR

Codewheel installation instructions

1. Place codewheel on shaft
2. Set codewheel height using Set Height Tool
 - a) Place the set height tool on the Module mounting surface, where the 2 guide pins being inserted into the 2 mounting holes;
 - b) Push the codewheel toward the set height tool until touching the tool. The codewheel is now at the proper height;
 - c) Tighten both codewheel set screws.
3. Remove the set height tool
4. Install encoder module.

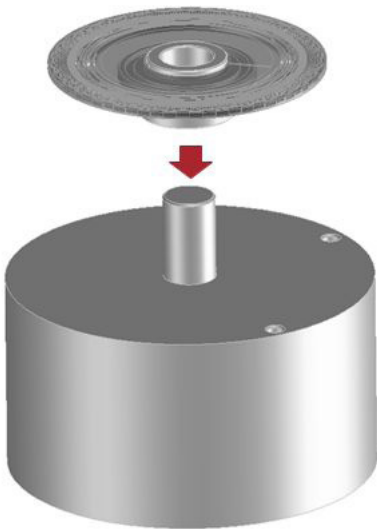

Figure 1a. Mount the CW with hub to shaft

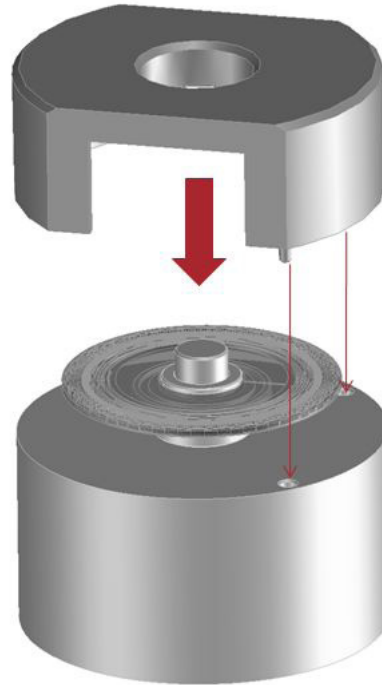

Figure 1b. Place the set height tool

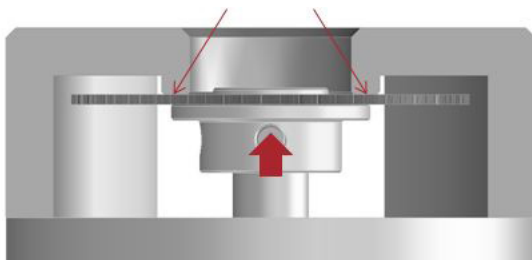

Figure 1c. Push the CW until touching the set height tool



Figure 1d. Tighten the set screws

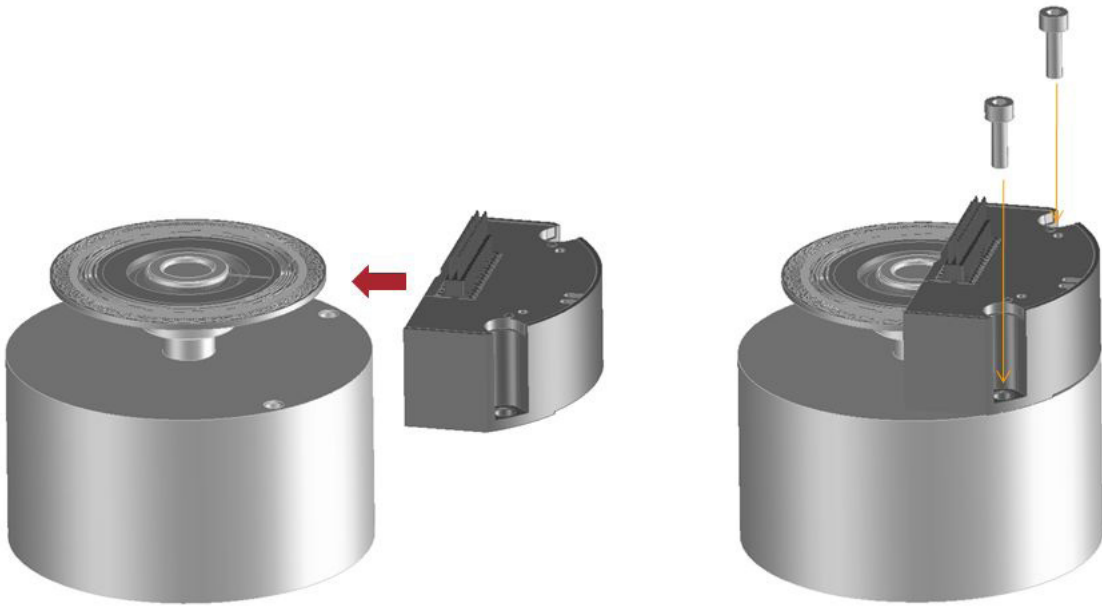
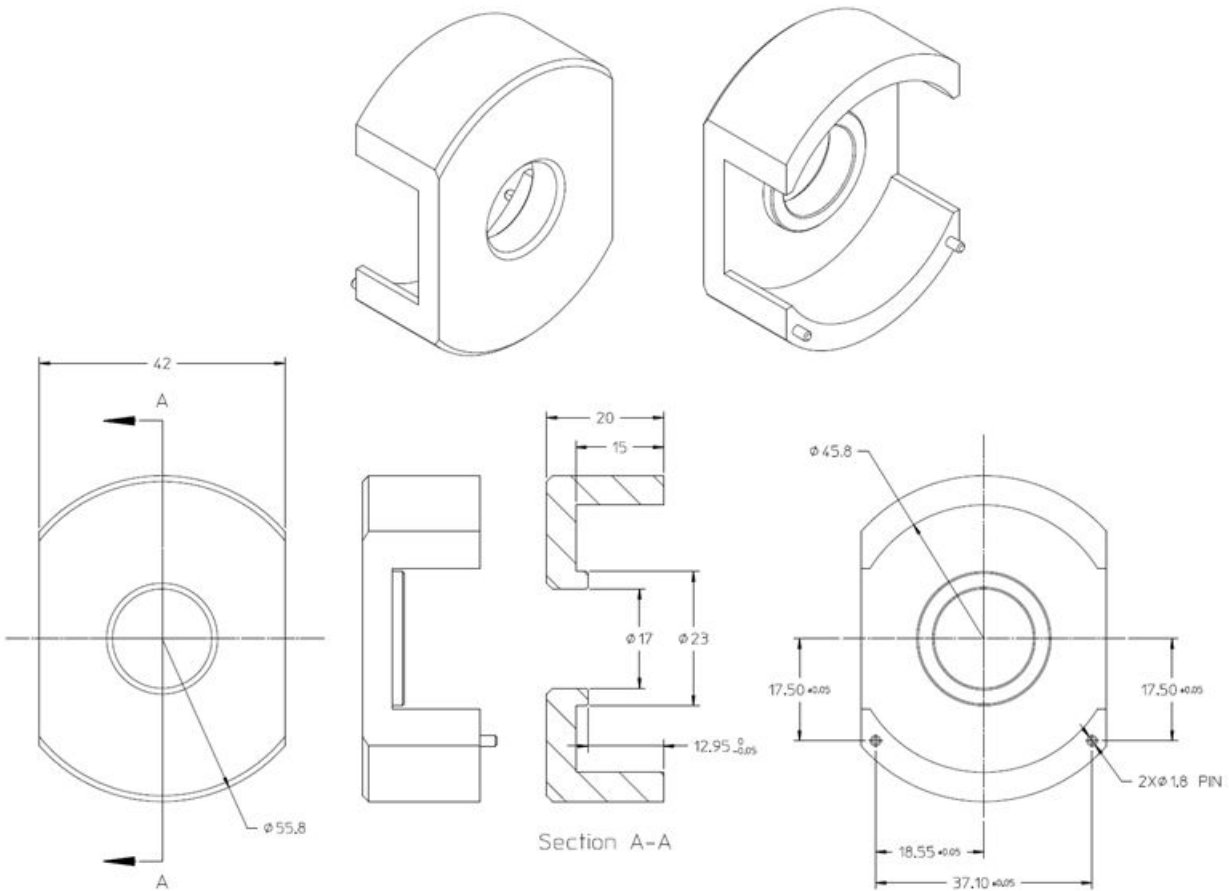

Figure 1e. Remove the set height tool and install encoder module

Recommended set height tool design



- Notes:
1. All dimensions are in millimeter.
 2. Tolerance: $X.X \pm 0.20$ mm.

Figure 2. Recommended Set Height Tool Design and Dimension

Codewheel Dimension

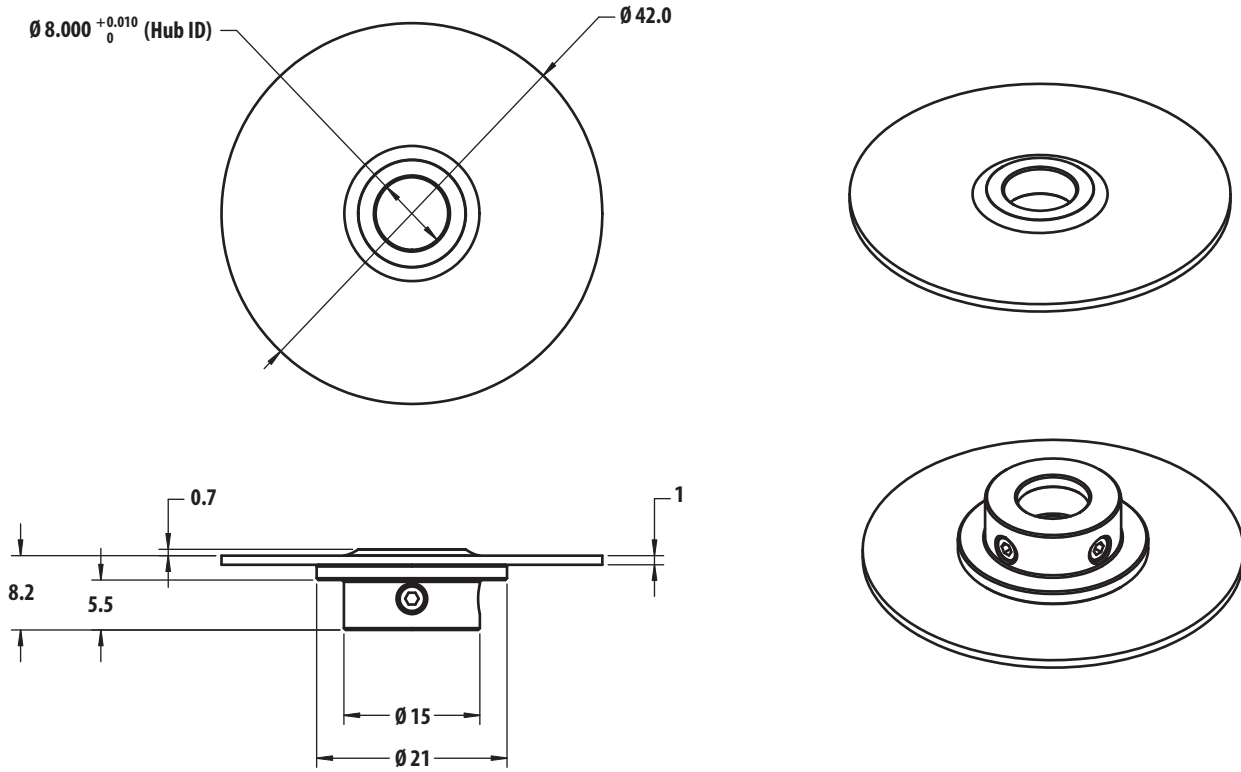

Notes:

1. All dimensions are in millimeter.
2. Tolerance: $X.X \pm 0.20$ mm.

Figure 3a. Dimension for codewheel with hub

HEDG-9000-H14

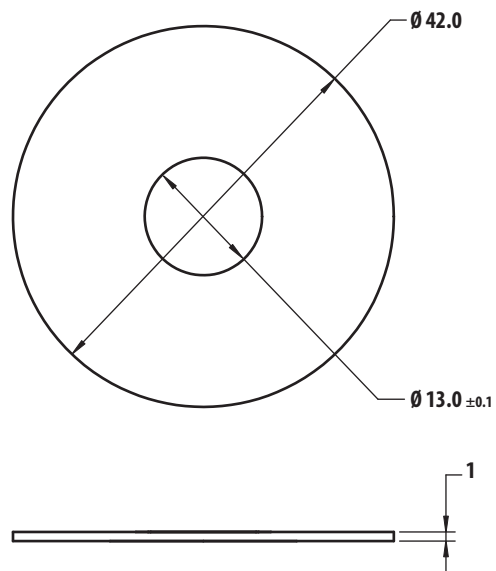

Notes:

1. All dimensions are in millimeter.
2. Tolerance: $X.X \pm 0.20$ mm.

Figure 3b. Bare Codewheel Dimension

Ordering Information

HEDG - 9000 - H 1

3 – Codewheel with hub
4 – Bare Codewheel

For product information and a complete list of distributors, please go to our web site: www.avagotech.com

Avago, Avago Technologies, and the A logo are trademarks of Avago Technologies in the United States and other countries.
Data subject to change. Copyright © 2005-2011 Avago Technologies. All rights reserved.
AV02-3147EN - August 25, 2011

AVAGO
TECHNOLOGIES

Данный компонент на территории Российской Федерации

Вы можете приобрести в компании MosChip.

Для оперативного оформления запроса Вам необходимо перейти по данной ссылке:

<http://moschip.ru/get-element>

Вы можете разместить у нас заказ для любого Вашего проекта, будь то серийное производство или разработка единичного прибора.

В нашем ассортименте представлены ведущие мировые производители активных и пассивных электронных компонентов.

Нашей специализацией является поставка электронной компонентной базы двойного назначения, продукции таких производителей как XILINX, Intel (ex.ALTERA), Vicor, Microchip, Texas Instruments, Analog Devices, Mini-Circuits, Amphenol, Glenair.

Сотрудничество с глобальными дистрибьюторами электронных компонентов, предоставляет возможность заказывать и получать с международных складов практически любой перечень компонентов в оптимальные для Вас сроки.

На всех этапах разработки и производства наши партнеры могут получить квалифицированную поддержку опытных инженеров.

Система менеджмента качества компании отвечает требованиям в соответствии с ГОСТ Р ИСО 9001, ГОСТ РВ 0015-002 и ЭС РД 009

Офис по работе с юридическими лицами:

105318, г.Москва, ул.Щербаковская д.3, офис 1107, 1118, ДЦ «Щербаковский»

Телефон: +7 495 668-12-70 (многоканальный)

Факс: +7 495 668-12-70 (доб.304)

E-mail: info@moschip.ru

Skype отдела продаж:

moschip.ru

moschip.ru_4

moschip.ru_6

moschip.ru_9