

# HCPL-1930, HCPL-1931, HCPL-193K, 5962-89572

Dual Channel Line Receiver Hermetically Sealed Optocoupler



## Data Sheet

### Description

The HCPL-193X devices are dual channel, hermetically sealed, high CMR, line receiver optocouplers. The products are capable of operation and storage over the full military temperature range and can be purchased as either a standard product or with full MIL-PRF-38534 Class Level H or K testing, or from the DLA Standard Microcircuit Drawing (SMD) 5962-89572. This sixteen pin DIP may be purchased with a variety of lead bend and plating options. See selection guide table for details. Standard Microcircuit Drawing (SMD) parts are available for each lead style.

### Functional Diagram

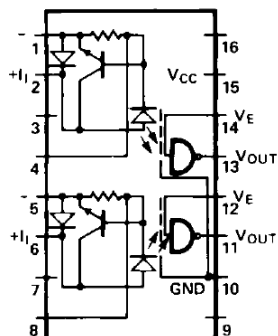

### Truth Table (Positive Logic)

INPUT	ENABLE	OUTPUT
ON	H	L
OFF	H	H
ON	L	H
OFF	L	H

### Features

- Dual marked with device part number and DLA standard microcircuit drawing
- Manufactured and tested on a MIL-PRF-38534 certified line
- QML-38534, Class H and Class K
- Hermetically sealed 16-pin dual in-line package
- Performance guaranteed over full military temperature range: -55° C to +125° C
- High speed – 10 Mb/s
- Accepts a broad range of drive conditions
- Adaptive line termination included
- Internal shield provides excellent common mode rejection
- External base lead allows “LED Peaking” and LED current adjustment
- 1500 Vdc withstand test voltage
- High radiation immunity
- HCPL-2602 function compatibility
- Reliability data available

### Applications

- Military and space
- High reliability systems
- Isolated line receiver
- Simplex/multiplex data transmission
- Computer-peripheral interface
- Microprocessor system interface
- Harsh environmental environments
- Digital isolation for A/D, D/A conversion
- Current sensing
- Instrument input/output isolation
- Ground loop elimination
- Pulse transformer replacement

Note: The connection of a 0.1  $\mu$ F bypass capacitor between pins 15 and 10 is recommended.

**CAUTION:** It is advised that normal static precautions be taken in handling and assembly of this component to prevent damage and/or degradation which may be induced by ESD.

All devices are manufactured and tested on a MIL-PRF-38534 certified line and are included in the DLA Qualified Manufacturers List QML-38534 for Hybrid Microcircuits.

Each unit contains two independent channels, consisting of a GaAsP light emitting diode, an input current regulator, and an integrated high gain photon detector. The input regulator serves as a line termination for line receiver applications. It clamps the line voltage and regulates the LED current so line reflections do not interfere with circuit performance. The regulator allows a typical LED current of 12.5 mA before it starts to shunt excess current. The output of the detector IC is an open collector Schottky clamped transistor. An enable input gates the detector. The internal detector shield provides a guaranteed common mode transient immunity specification of +1000V/ $\mu$ sec.

DC specifications are compatible with TTL logic and are guaranteed from -55° C to +125° C allowing trouble-free interfacing with digital logic circuits. An input current of 10 mA will sink a six gate fan-out (TTL) at the output with a typical propagation delay from input to output of only 45 nsec.

## Selection Guide—Lead Configuration Options

<b>Avago Part # and Options</b>	
Commercial	HCPL-1930
MIL-PRF-38534 Class H	HCPL-1931
MIL-PRF-38534 Class K	HCPL-193K
Standard Lead Finish	Gold
Solder Dipped*	Option #200
Butt Joint/Gold Plate	Option #100
Gull Wing/Soldered*	Option #300
Crew Cut/Gold Plate	Option #600
<b>Class H SMD Part #</b>	
<i>Prescript for all below</i>	5962-
Gold Plate	8957201EC
Solder Dipped*	8957201EA
Butt Joint/Gold Plate	8957201YC
Butt Joint/Soldered*	8957201YA
Gull Wing/Soldered*	8957201XA
Crew Cut/Gold Plate	Available
Crew Cut/Soldered*	Available
<b>Class K SMD Part #</b>	
<i>Prescript for all below</i>	5962-
Gold Plate	8957202KEC
Solder Dipped*	8957202KEA
Butt Joint/Gold Plate	8957202KYC
Butt Joint/Soldered*	8957202KYA
Gull Wing/Soldered*	8957202KXA

\*Solder contains lead.

## Outline Drawings

### 16 Pin DIP Through Hole, 2 Channels

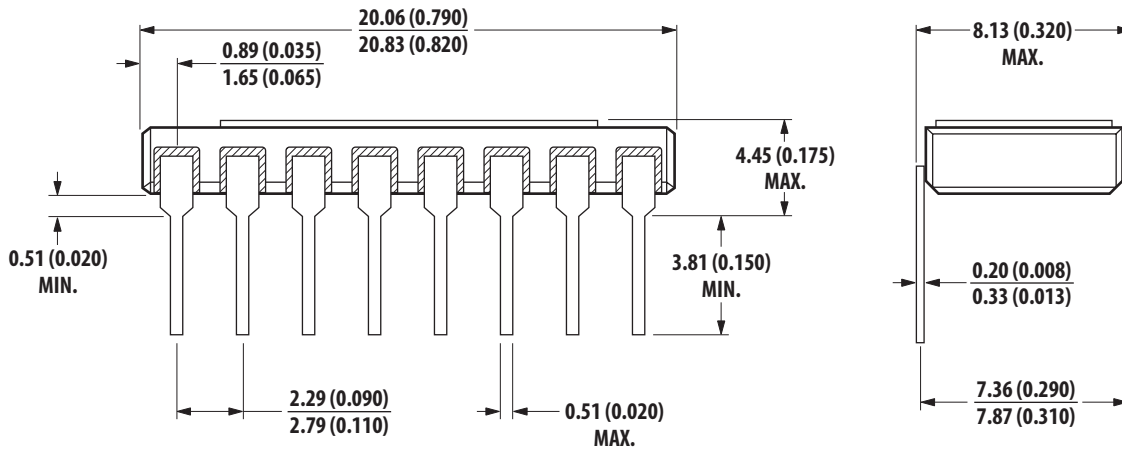

Note: Dimensions in millimeters (inches).

## Device Marking

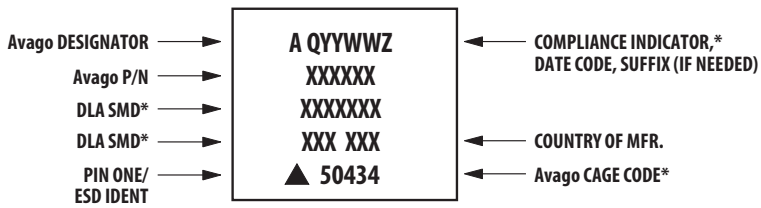

\* QUALIFIED PARTS ONLY

## Hermetic Optocoupler Options

Option	Description
100	Surface mountable hermetic optocoupler with leads trimmed for butt joint assembly. This option is available on commercial and hi-rel product.

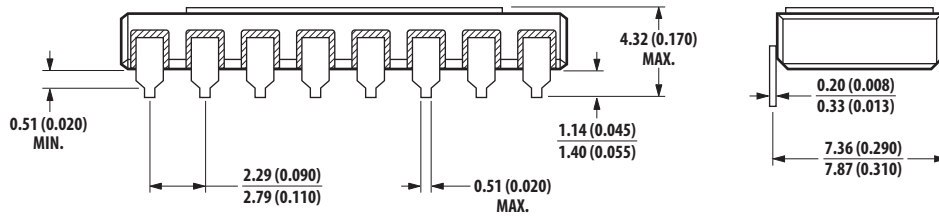

200	Lead finish is solder dipped rather than gold plated. This option is available on commercial and hi-rel product. DLA Drawing part numbers contain provisions for lead finish.
-----	---

300	Surface mountable hermetic optocoupler with leads cut and bent for gull wing assembly. This option is available on commercial and hi-rel product. This option has solder dipped leads.
-----	--

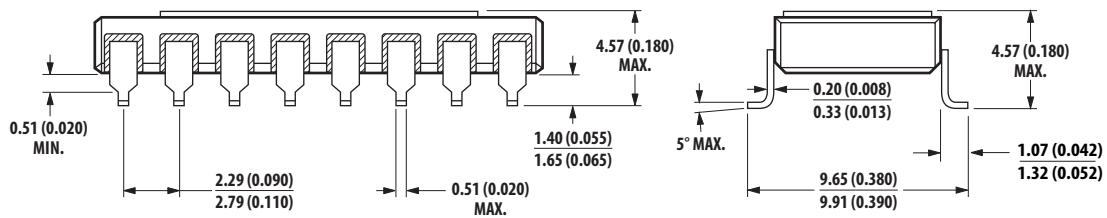

600	Surface mountable hermetic optocoupler with leads trimmed for butt joint assembly. This option is available on commercial and hi-rel product. Contact factory for the availability of this option on DLA part types.
-----	--

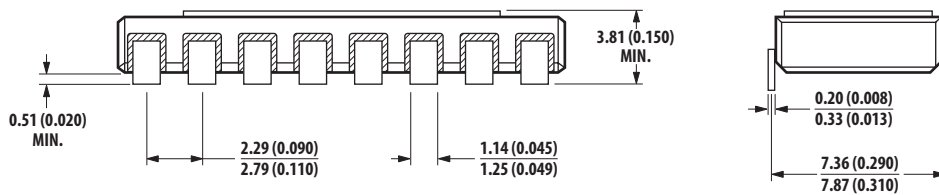

Notes: Dimensions in millimeters (inches).  
Solder contains lead.

## Absolute Maximum Ratings

Parameter	Symbol	Min.	Max.	Units	Note
Storage Temperature	$T_S$	-65	+150	°C	
Operating Temperature	$T_A$	-55	+125	°C	
Lead Solder Temperature			260 for 10 sec	°C	
Forward Input Current (each channel)	$I_I$		60	mA	2
Reverse Input Current	$I_R$		60	mA	
Supply Voltage (1 minute max)	$V_{CC}$		7.0	V	
Enable Input Voltage (each channel)	$V_E$		5.5*	V	
Output Collector Current (each channel)	$I_O$		25	mA	
Output Collector Power Dissipation (each channel)	$P_O$		40	mW	
Output Collector Voltage (each channel)	$V_O$		7	V	
Total Package Power Dissipation			564	mW	
Input Power Dissipation (each channel)			168	mW	

\* not to exceed  $V_{CC}$  by more than 500 mV

## Schematic

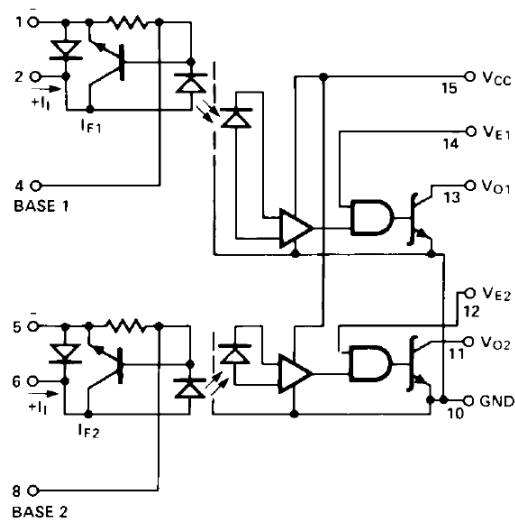

A 0.1  $\mu$ F bypass capacitor must be connected between pins 10 and 15 (see note 1).

## ESD Classification

(MIL-STD-883, Method 3015)

(▲), Class 1

## Recommended Operating Conditions

Parameter	Symbol	Min.	Max.	Units
Input Current, Low Level	$I_{IL}$	0	250	$\mu$ A
Input Current, High Level*	$I_{IH}$	12.5	60	mA
Supply Voltage, Output	$V_{CC}$	4.5	5.5	V
High Level Enable Voltage	$V_{EH}$	2.0	$V_{CC}$	V
Low Level Enable Voltage	$V_{EL}$	0	0.8	V
Fan Out (@ $R_L = 4 \text{ k}\Omega$ )	N		5	TTL Loads
Operating Temperature	$T_A$	-55	125	°C

\*12.5 mA condition permits at least 20% guardband for optical coupling variation. Initial switching threshold is 10 mA or less.

## Electrical Specifications

T<sub>A</sub> = -55° C to 125° C unless otherwise stated. See note 15.

Parameter	Symbol	Test Conditions	Group A Sub-groups	Limits			Units	Fig.	Note
				Min.	Typ.*	Max.			
High Level Output Current	I <sub>OH</sub>	V <sub>CC</sub> = 5.5 V, V <sub>O</sub> = 5.5 V I <sub>I</sub> = 250 μA, V <sub>E</sub> = 2.0 V	1, 2, 3		20	250	μA	3	3
Low Level Output Voltage	V <sub>OL</sub>	V <sub>CC</sub> = 5.5 V; I <sub>I</sub> = 10 mA V <sub>E</sub> = 2.0 V, I <sub>OL</sub> (Sinking) = 10 mA	1, 2, 3		0.3	0.6	V	1	3
Input Voltage	V <sub>I</sub>	I <sub>I</sub> = 10 mA	1, 2, 3		2.2	2.6	V	2	3
					2.35	2.75			
Input Reverse Voltage	V <sub>R</sub>	I <sub>R</sub> = 10 mA	1, 2, 3		0.8	1.10	V		3
Low Level Enable Current	I <sub>EL</sub>	V <sub>CC</sub> = 5.5 V, V <sub>E</sub> = 0.5 V	1, 2, 3		-1.45	-2.0	mA		3
High Level Enable Current	I <sub>EH</sub>	V <sub>CC</sub> = 5.5 V, V <sub>E</sub> = 1.7 V	1, 2, 3			-1.5	mA		3
High Level Enable Voltage	V <sub>EH</sub>		1, 2, 3	2.0			V		3, 12
Low Level Enable Voltage	V <sub>EL</sub>		1, 2, 3			0.8	V		3
High Level Supply Current	I <sub>CCH</sub>	V <sub>CC</sub> = 5.5 V; I <sub>I</sub> = 0, V <sub>E</sub> = 0.5 V both channels	1, 2, 3		21	28	mA		
Low Level Supply Current	I <sub>CCL</sub>	V <sub>CC</sub> = 5.5 V; I <sub>I</sub> = 60 mA, V <sub>E</sub> = 0.5 V both channels	1, 2, 3		27	36	mA		
Input-Output Insulation Leakage Current	I <sub>I-O</sub>	Relative Humidity ≤ 65% t = 5 s, V <sub>I-O</sub> = 1500 Vdc	1			1	μA		4
Propagation Delay Time to High Output Level	t <sub>PLH</sub>	R <sub>L</sub> = 510 Ω; C <sub>L</sub> = 50 pF, I <sub>I</sub> = 13 mA, V <sub>CC</sub> = 5.0 V	9		55	100	ns	4, 5	3, 5
			10, 11			140			
Propagation Delay Time to Low Output Level	t <sub>PHL</sub>	R <sub>L</sub> = 510 Ω; C <sub>L</sub> = 50 pF, I <sub>I</sub> = 13 mA, V <sub>CC</sub> = 5.0 V	9		60	100	ns	4, 5	3, 6
			10, 11			120			
Common Mode Transient Immunity at High Output Level	CM <sub>H</sub>	V <sub>CM</sub> = 50 V (peak), V <sub>O</sub> (min.) = 2 V, R <sub>L</sub> = 510 Ω; I <sub>I</sub> = 0 mA, V <sub>CC</sub> = 5.0 V	9, 10, 11	1000	10,000		V/μs	8, 9	3, 9, 14
Common Mode Transient Immunity at Low Output Level	CM <sub>L</sub>	V <sub>CM</sub> = 50 V (peak), V <sub>O</sub> (max.) = 0.8 V, R <sub>L</sub> = 510 Ω; I <sub>I</sub> = 10 mA, V <sub>CC</sub> = 5.0 V	9, 10, 11	1000	10,000		V/μs	8, 9	3, 10, 14

\*All typical values are at V<sub>CC</sub> = 5 V, T<sub>A</sub> = 25° C.

## Typical Specifications

$T_A = 25^\circ\text{C}$ ,  $V_{CC} = 5\text{V}$

Parameter	Symbol	Typ.	Units	Test Conditions	Fig.	Note
Resistance (Input-Output)	$R_{I-O}$	$10^{12}$	$\Omega$	$V_{I-O} = 500\text{V dc}$		3, 13
Capacitance (Input-Output)	$C_{I-O}$	1.7	pF	$f = 1\text{ MHz}$		3, 13
Input-Input Insulation Leakage Current	$I_{I-I}$	0.5	nA	$\leq 65\%$ Relative Humidity, $V_{I-I} = 500\text{Vdc}$ , $t = 5\text{ s}$		11
Resistance (Input-Input)	$R_{I-I}$	1012	$\Omega$	$V_{I-I} = 500\text{Vdc}$		11
Capacitance (Input-Input)	$C_{I-I}$	0.55	pF	$f = 1\text{ MHz}$		11
Propagation Delay Time of Enable from $V_{EH}$ to $V_{EL}$	$t_{ELH}$	35	ns	$R_L = 510\ \Omega$ , $C_L = 15\text{ pF}$ , $I_I = 13\text{ mA}$ , $V_{EH} = 3\text{ V}$ , $V_{EL} = 0\text{ V}$	6, 7	3, 7
Propagation Delay Time of Enable from $V_{EL}$ to $V_{EH}$	$t_{EHL}$	35	ns		6, 7	3, 8
Output Rise Time (10-90%)	$t_r$	30	ns	$R_L = 510\ \Omega$ , $C_L = 15\text{ pF}$ , $I_I = 13\text{ mA}$		3
Output Fall Time (90-10%)	$t_f$	24	ns			3
Input Capacitance	$C_I$	60	pF	$f = 1\text{ MHz}$ , $V_I = 0$ , PINS 1 to 2 or 5 to 6		3

### Notes:

- Bypassing of the power supply line is required, with a 0.1  $\mu\text{F}$  ceramic disc capacitor adjacent to each isolator. The power supply bus for the isolators should be separate from the bus for any active loads, otherwise additional bypass capacitance may be needed to suppress regenerative feedback via the power supply.
- Derate linearly at 1.2 mA/ $^\circ\text{C}$  above  $T_A = 100^\circ\text{C}$ .
- Each channel.
- Device considered a two terminal device: pins 1 through 8 are shorted together, and pins 9 through 16 are shorted together.
- The  $t_{PLH}$  propagation delay is measured from the 6.5 mA point on the trailing edge of the input pulse to the 1.5 V point on the trailing edge of the output pulse.
- The  $t_{PHL}$  propagation delay is measured from the 6.5 mA point on the leading edge of the input pulse to the 1.5 V point on the leading edge of the output pulse.
- The  $t_{ELH}$  enable propagation delay is measured from the 1.5 V point on the trailing edge of the enable input pulse to the 1.5 V point on the trailing edge of the output pulse.
- The  $t_{EHL}$  enable propagation delay is measured from the 1.5 V point on the leading edge of the enable input pulse to the 1.5 V point on the leading edge of the output pulse.
- $CM_H$  is the maximum tolerable rate of rise of the common mode voltage to assure that the output will remain in a high logic state, i.e.  $V_{OUT} > 2.0\text{V}$ .
- $CM_L$  is the maximum tolerable rate of fall of the common mode voltage to assure that the output will remain in a low logic state, i.e.  $V_{OUT} < 0.8\text{V}$ .
- Measured between adjacent input leads shorted together, i.e. between 1, 2 and 4 shorted together and pins 5, 6 and 8 shorted together.
- No external pull up is required for a high logic state on the enable input.
- Measured between pins 1 and 2 or 5 and 6 shorted together, and pins 10 through 15 shorted together.
- Parameters shall be tested as part of device initial characterization and after process changes. Parameters shall be guaranteed to the limits specified for all lots not specifically tested.
- Standard parts receive 100% testing at  $25^\circ\text{C}$  (Subgroups 1 and 9). Hi-Rel and SMD parts receive 100% testing at 25, 125, and  $-55^\circ\text{C}$  (Subgroups 1 and 9, 2 and 10, 3 and 11, respectively).

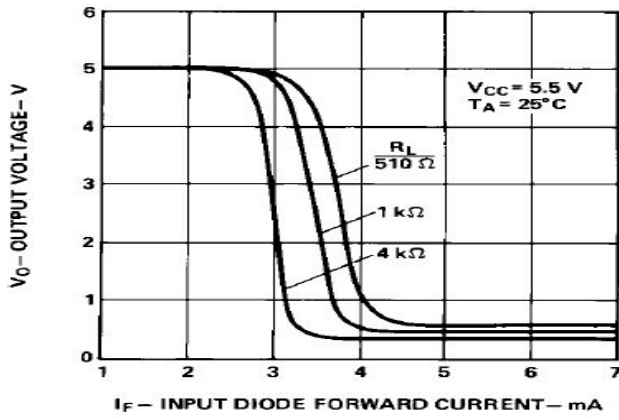

Figure 1. Input-Output Characteristics.

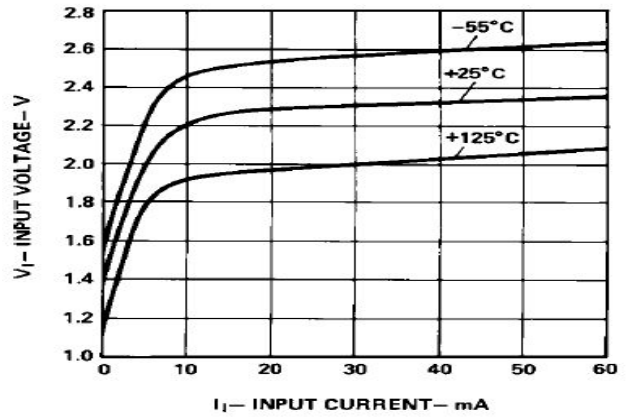

Figure 2. Input Characteristics.

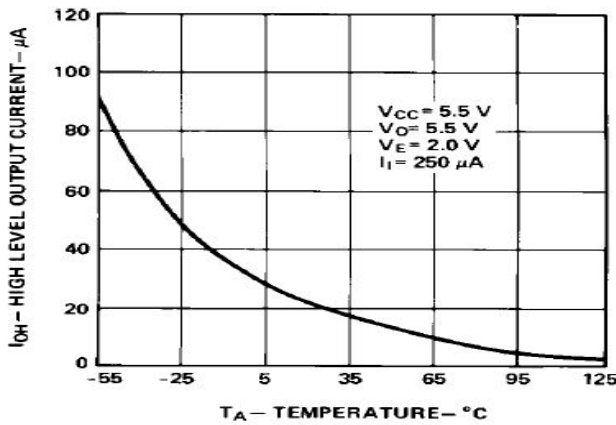

Figure 3. High Level Output Current vs. Temperature.

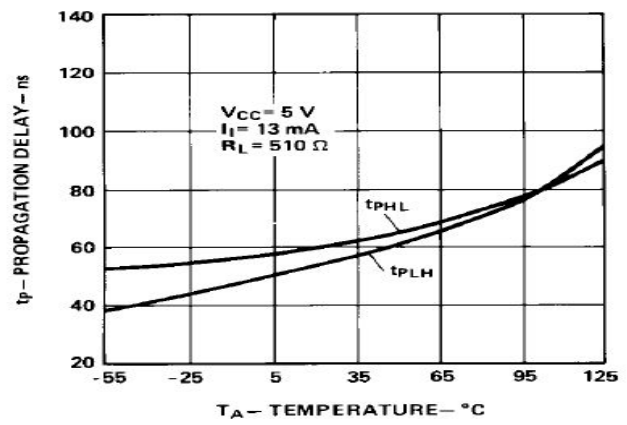

Figure 4. Propagation Delay vs. Temperature.

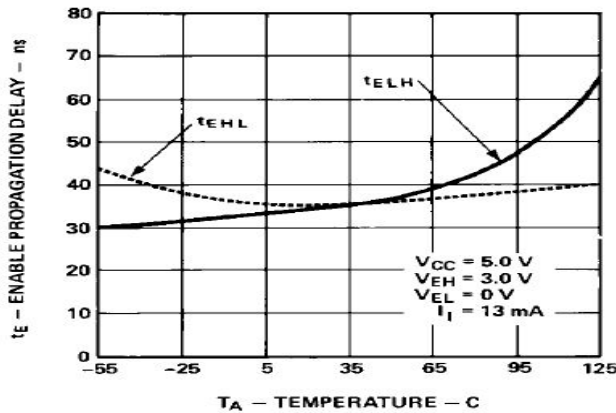
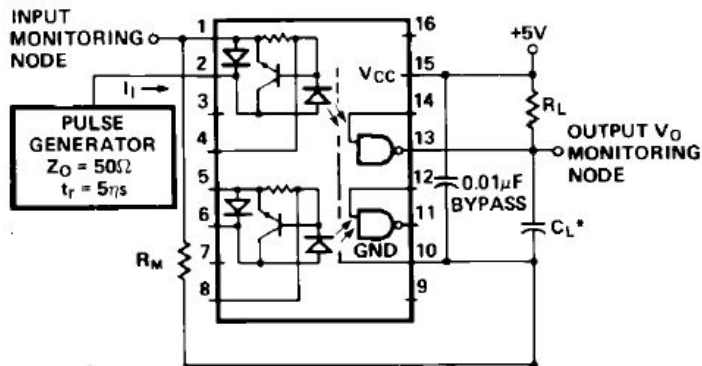

Figure 5. Enable Propagation Delay vs. Temperature.





\* $C_L$  INCLUDES PROBE AND STRAY WIRING CAPACITANCE

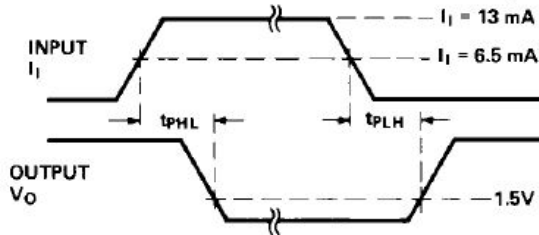
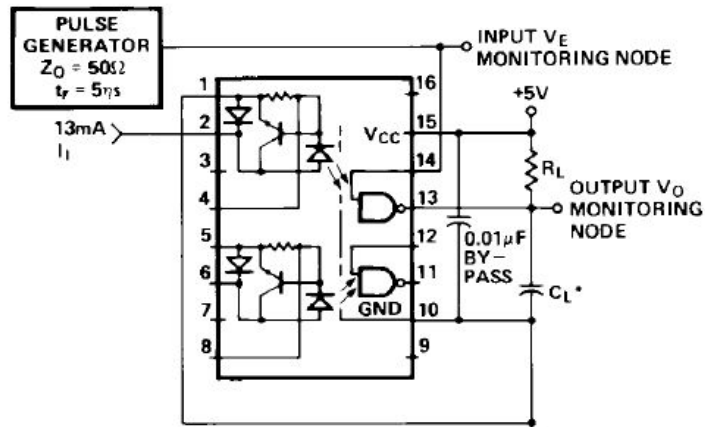

Figure 6. Test Circuit for  $t_{PHL}$  and  $t_{PLH}$ .



\* $C_L$  INCLUDES PROBE AND STRAY WIRING CAPACITANCE

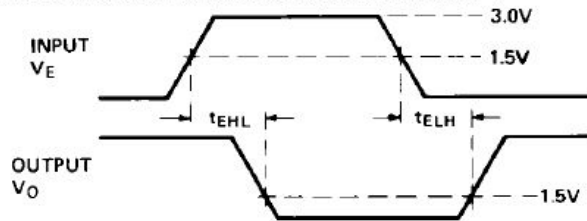

Figure 7. Test Circuit for  $t_{EHL}$  and  $t_{ELH}$ .

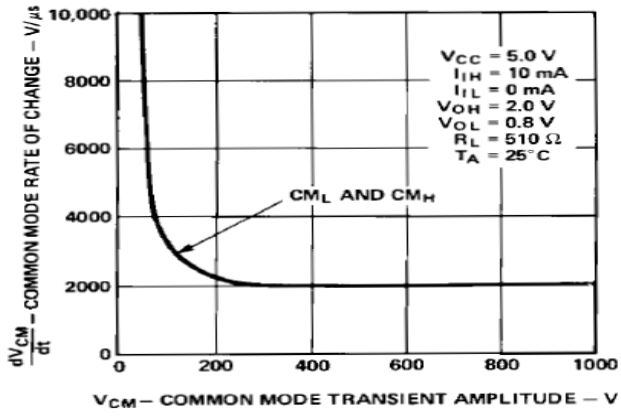

Figure 8. Typical Common Mode Transient Immunity.

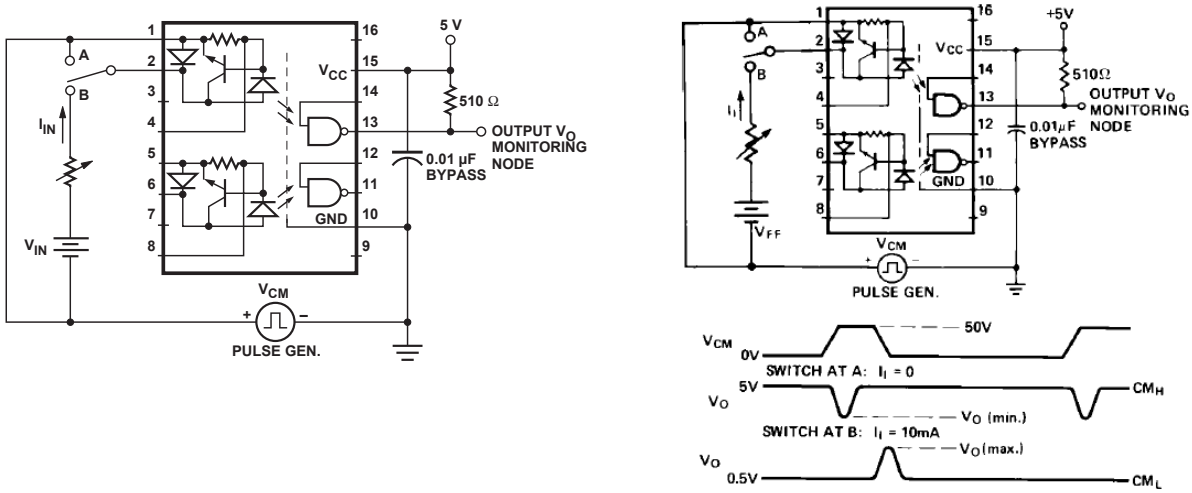

Figure 9. Test Circuit for Common Mode Transient Immunity and Typical Waveforms.

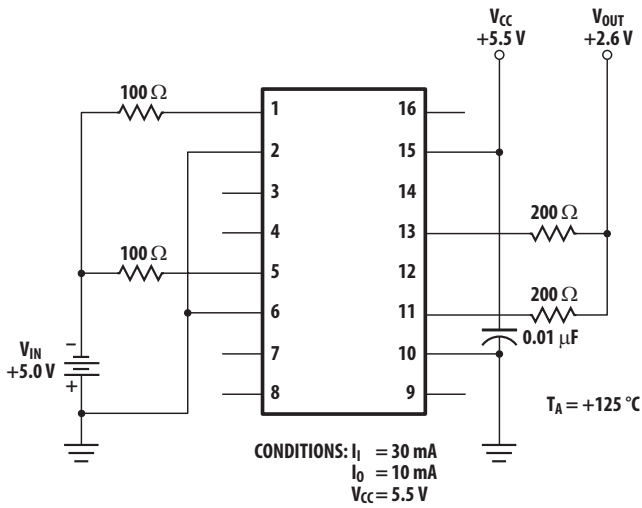

Figure 10. Burn In Circuit.

## Application Circuits\*

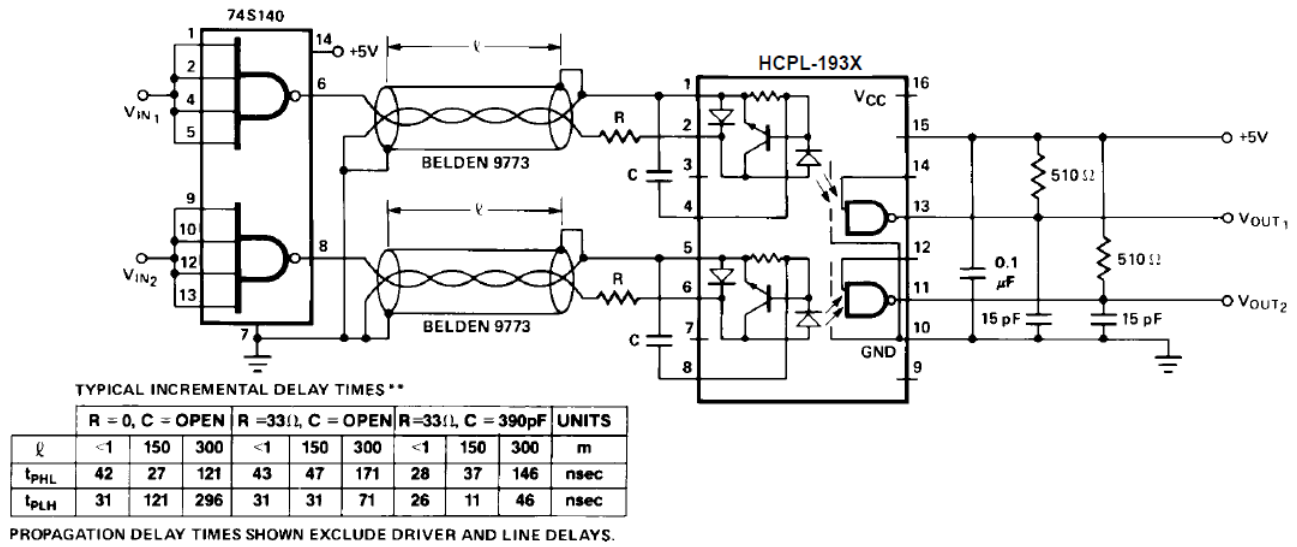

Figure A1. Polarity Non-Reversing.

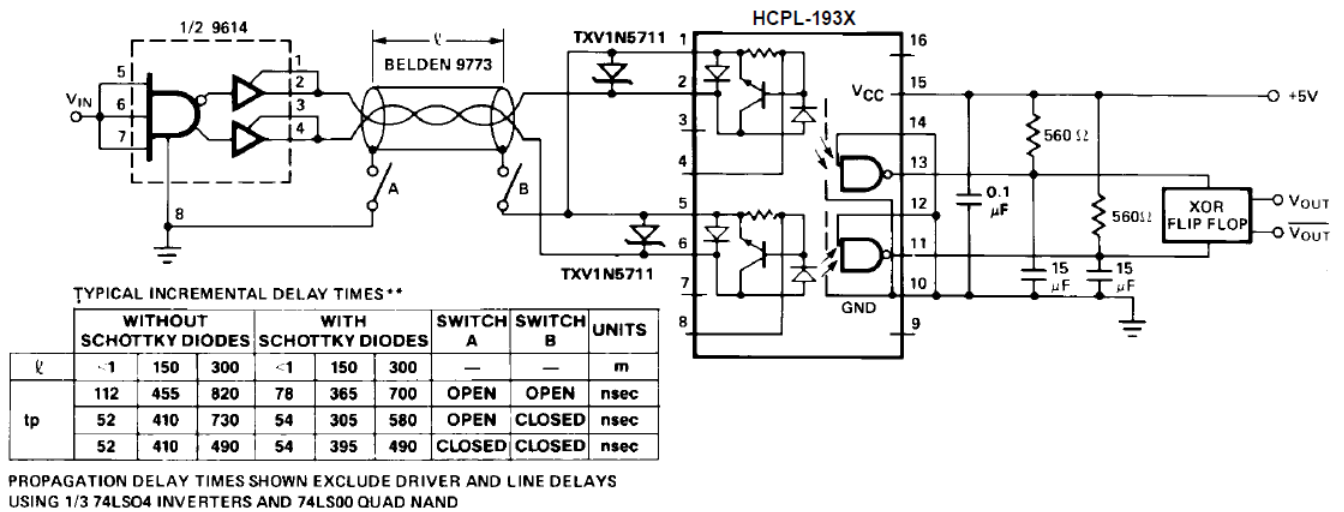
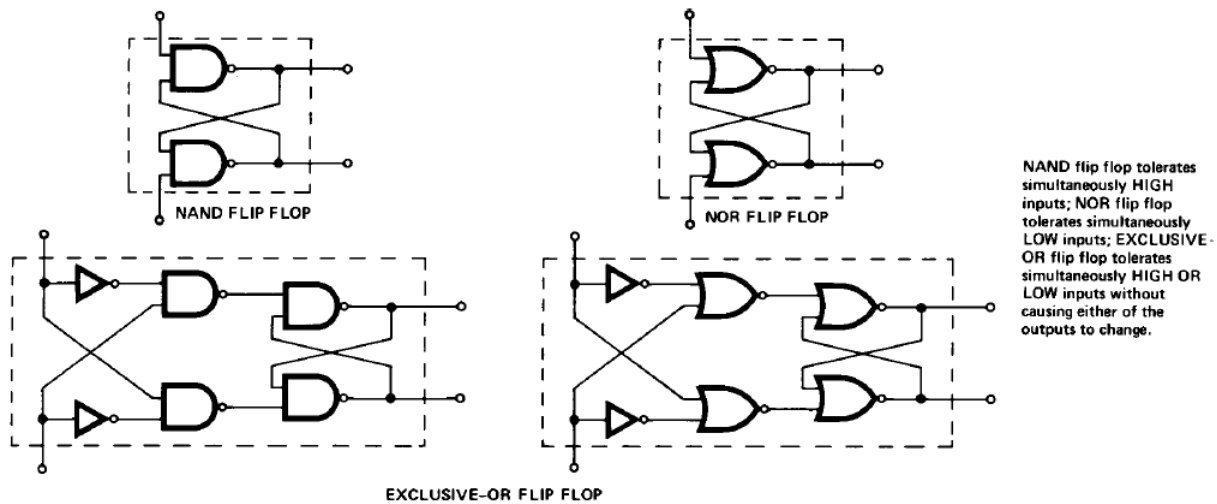

Figure A2. Polarity Reversing, Split Phase.



\*FOR A DESCRIPTION OF THESE CIRCUITS SEE HCPL-2602 DATA SHEET.

Figure A3. Flop-Flop Configurations.

### MIL-PRF-38534 Class H, Class K, and DLA SMD Test Program

Avago Technologies' Hi-Rel Optocouplers are in compliance with MIL-PRF-38534 Class H and K. Class H and Class K devices are also in compliance with DLA drawing 5962-89572.

Testing consists of 100% screening and quality conformance inspection to MIL-PRF-38534.

For product information and a complete list of distributors, please go to our web site: [www.avagotech.com](http://www.avagotech.com)

Avago, Avago Technologies, and the A logo are trademarks of Avago Technologies in the United States and other countries. Data subject to change. Copyright © 2005-2012 Avago Technologies. All rights reserved. Obsoletes 5968-9401E AV02-3843EN - October 17, 2012

**AVAGO**  
TECHNOLOGIES

## Данный компонент на территории Российской Федерации

### Вы можете приобрести в компании MosChip.

Для оперативного оформления запроса Вам необходимо перейти по данной ссылке:

<http://moschip.ru/get-element>

Вы можете разместить у нас заказ для любого Вашего проекта, будь то серийное производство или разработка единичного прибора.

В нашем ассортименте представлены ведущие мировые производители активных и пассивных электронных компонентов.

Нашей специализацией является поставка электронной компонентной базы двойного назначения, продукции таких производителей как XILINX, Intel (ex.ALTERA), Vicor, Microchip, Texas Instruments, Analog Devices, Mini-Circuits, Amphenol, Glenair.

Сотрудничество с глобальными дистрибьюторами электронных компонентов, предоставляет возможность заказывать и получать с международных складов практически любой перечень компонентов в оптимальные для Вас сроки.

На всех этапах разработки и производства наши партнеры могут получить квалифицированную поддержку опытных инженеров.

Система менеджмента качества компании отвечает требованиям в соответствии с ГОСТ Р ИСО 9001, ГОСТ РВ 0015-002 и ЭС РД 009

### Офис по работе с юридическими лицами:

105318, г.Москва, ул.Щербаковская д.3, офис 1107, 1118, ДЦ «Щербаковский»

Телефон: +7 495 668-12-70 (многоканальный)

Факс: +7 495 668-12-70 (доб.304)

E-mail: [info@moschip.ru](mailto:info@moschip.ru)

Skype отдела продаж:

moschip.ru

moschip.ru\_4

moschip.ru\_6

moschip.ru\_9