Interface circuit (relay and lamp driver)

Features

- High output current
- Adjustable short-circuit protection to ground
- Internal thermal protection with hysteresis to avoid the intermediate output levels
- Large supply voltage range: 8 to 30V
- Short-circuit protection to V_{CC}
- Open ground protection

Description

The TDE3247 is a monolithic amplifier designed for high current and high voltage applications, specifically to drive lamps, relays and stepping motors.

The Device is essentially blow-out proof. Current limiting is available to limit the peak output current to a safe value, the adjustment only required an external resistor.

In addition, thermal shut-down is provided to keep the IC from overheating.

If external dissipation becomes too high, the driver will shut-down to prevent excessive heating.

The output is also protected against short-circuit with the positive power supply.

The device operates over a wide range of supply voltage from standard $\pm 15V$ operational amplifier supplies down to the single 12V or 24V used for industrial electronic systems.

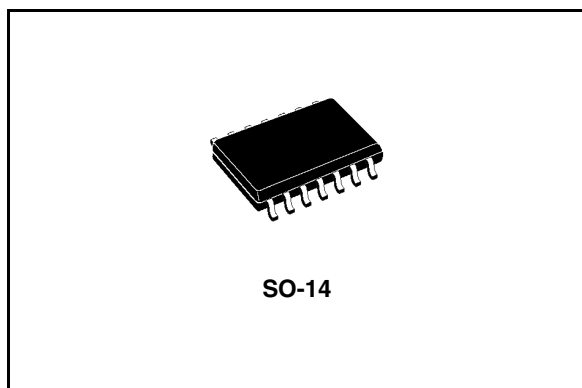
**Order codes**

Part number	Package	Packaging
TDE3247FP	SO-14	Tube
TDE3247FPT	SO-14	Tape & Reel

Contents

1	Schematic diagram and pin connections	3
2	Electrical ratings	4
3	Electrical characteristics	5
3.1	Electrical characteristics (curves)	6
4	Application circuit	8
5	Package mechanical data	9
6	Revision history	14

1 Schematic diagram and pin connections

Figure 1. Schematic diagram

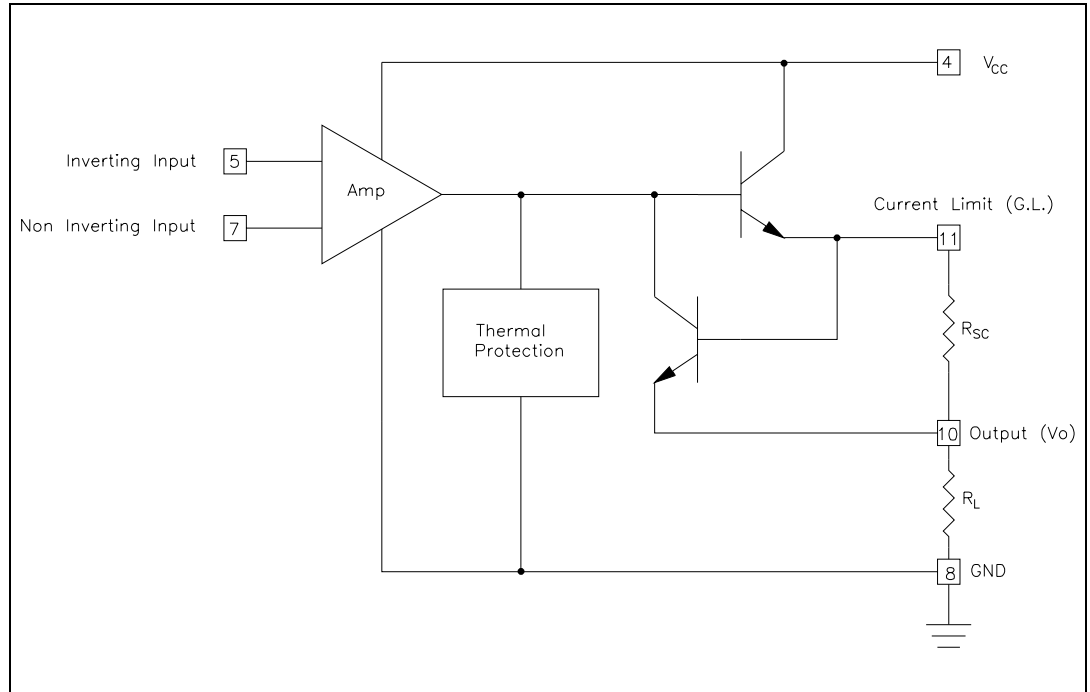
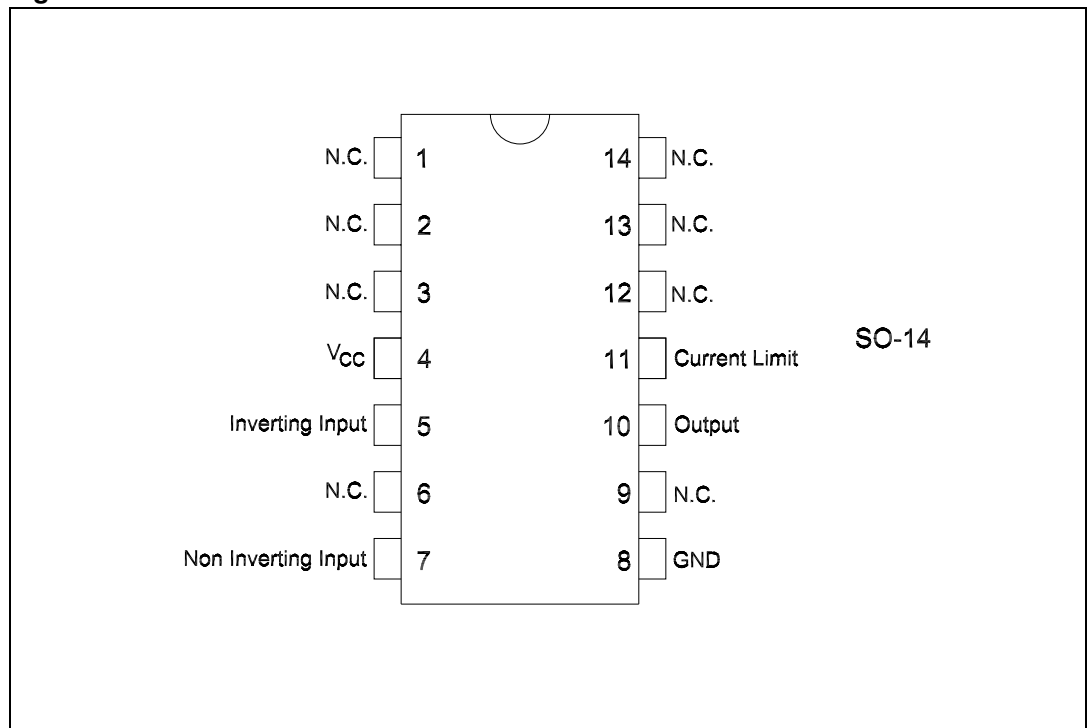

Figure 2. Pin connections



2 Electrical ratings

Table 1. Absolute maximum ratings

Symbol	Parameter	Value	Unit
V_{CC}	Supply Voltage	36	V
V_O	Differential Input Voltage	36	V
V_I	Input Voltage	36	V
I_O	Output Current	300	mA
P_{TOT}	Power Dissipation	Internally limited	W
T_{oper}	Ambient Temperature Range	-25 to 85	°C
T_{STG}	Storage Temperature Range	-65 to +150	°C

Table 2. Thermal data

R_{th}	Junction-ceramic Substrate (case glued to substrate) For SO-14	90	°C/W
R_{th}	Junction-ceramic Substrate (case glued to substrate, substrate temperature maintained constant) For SO-14	65	°C/W

3 Electrical characteristics

($-25^{\circ}\text{C} \leq T_A \leq 85^{\circ}\text{C}$, $8\text{V} \leq V_{CC} \leq 30\text{V}$, $I_O \leq 150\text{mA}$, $T_J \leq 150^{\circ}\text{C}$, unless otherwise specified) *Note: 1*

Table 3. Electrical characteristics

Symbol	Parameter	Test Conditions	Min.	Typ.	Max.	Unit
V_{IO}	Input Offset Voltage	<i>Note 2</i>		2	50	mV
I_{IB}	Input Bias Current			0.1	1.5	μA
I_{CC}	Supply Current	$V_{CC} = 24\text{V}$, $I_O = 0\text{A}$, $T_{\text{amb}} = 25^{\circ}\text{C}$				
		High Level		4	10	mA
		Low Level		2		mA
V_{CM}	Common Mode Input Voltage Range		2		$V_{CC}-2$	V
I_{SC}	Short-circuit Current	$V_{CC} = 24\text{V}$, $T_{\text{amb}} = 25^{\circ}\text{C}$ $R_{SC} = 3.3\Omega$		250		mA
$V_{CC} - V_O$	Output Saturation Voltage (Output High)	$(V_{I^+} - V_{I^-}) \leq 50\text{mV}$ $I_O = 150\text{mA}$, $R_{SC} = 0$ $T_J = 25^{\circ}\text{C}$		1.2	1.8	V
I_{OL}	Output Leakage Current (Output Low)	$V_O = 0\text{V}$, $V_{CC} = 24\text{V}$				
		$T_J = 25^{\circ}\text{C}$		1	100	μA
		$T_J = 85^{\circ}\text{C}$			500	μA
I_{OS}	Minimum Short-current Output Current	$T_{\text{amb}} = 25^{\circ}\text{C}$, $V_{CC} = 24\text{V}$ $R_{SC} = \infty$		50		mA

- Note:*
- 1 For operating at high temperatures, the device must be derated based on a 150°C maximum junction and a junction to ambient thermal resistance of $110^{\circ}\text{C}/\text{W}$
 - 2 The offset voltage given in the maximum value of input voltage required to drive the output voltage within 2V of the ground or the supply voltage.

3.1 Electrical characteristics (curves)

Figure 3. Available output current vs. limiting resistor

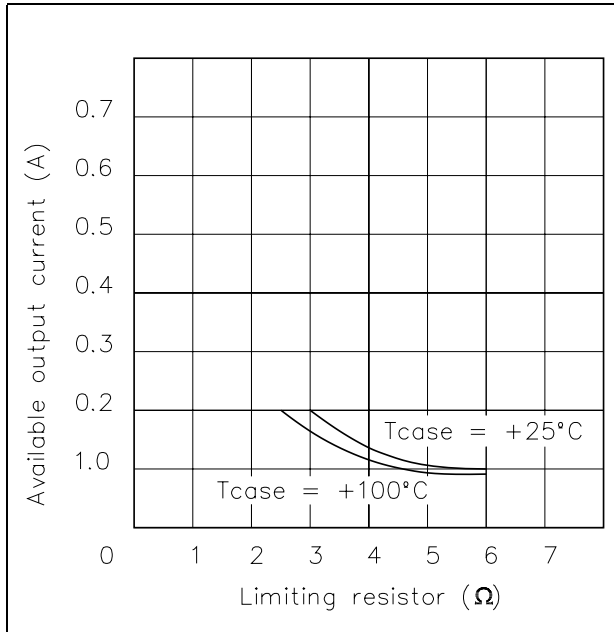

Figure 4. Supply current vs. junction temperature

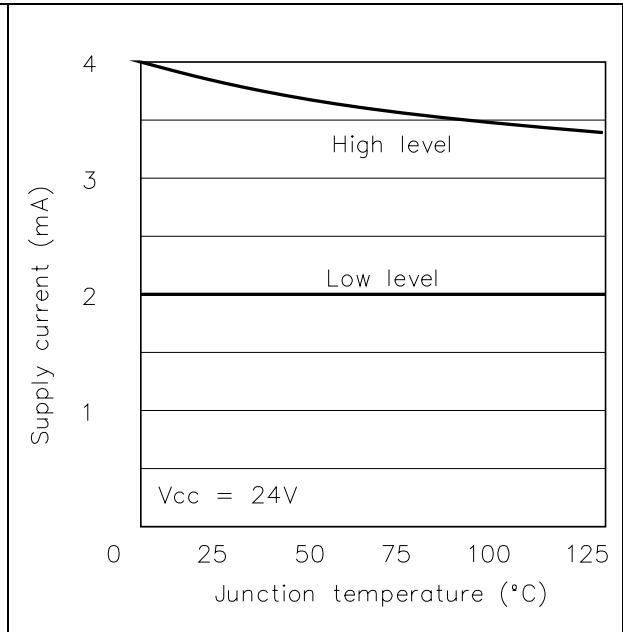

Figure 5. Saturation output voltage vs. case temperature and available output current

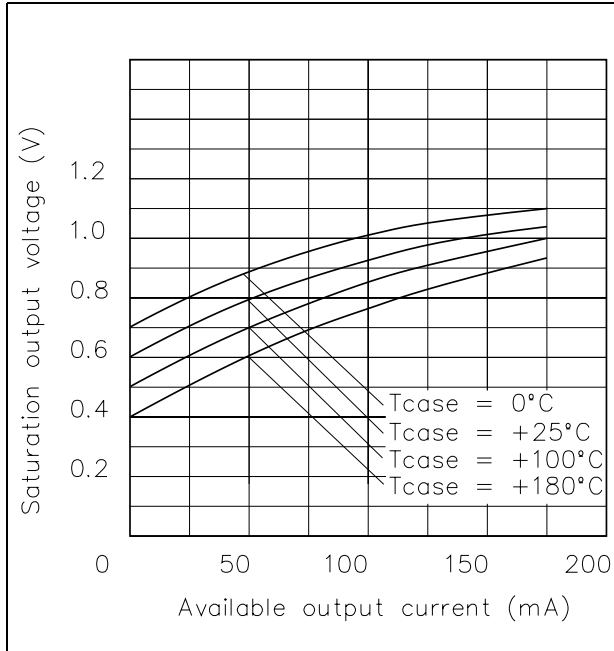

Figure 6. Supply current vs. supply voltage

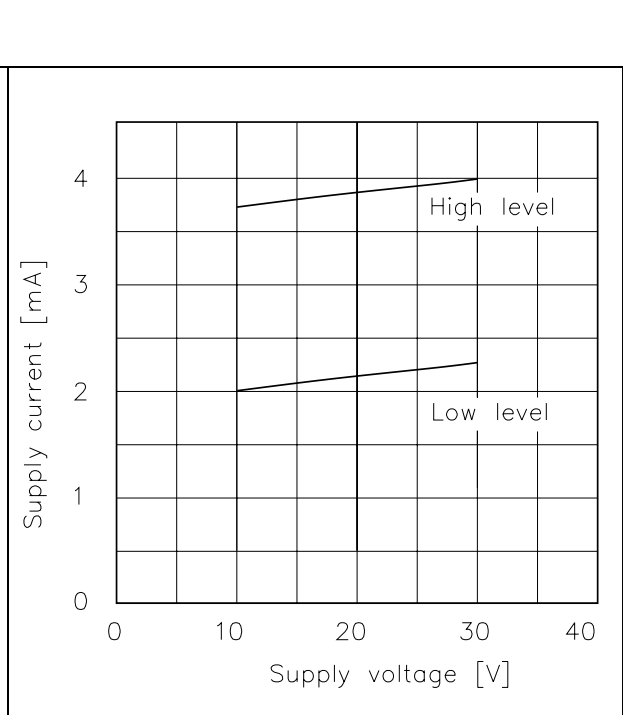

Figure 7. Supply voltage vs. minimum limiting resistor value **Figure 8. Response time**

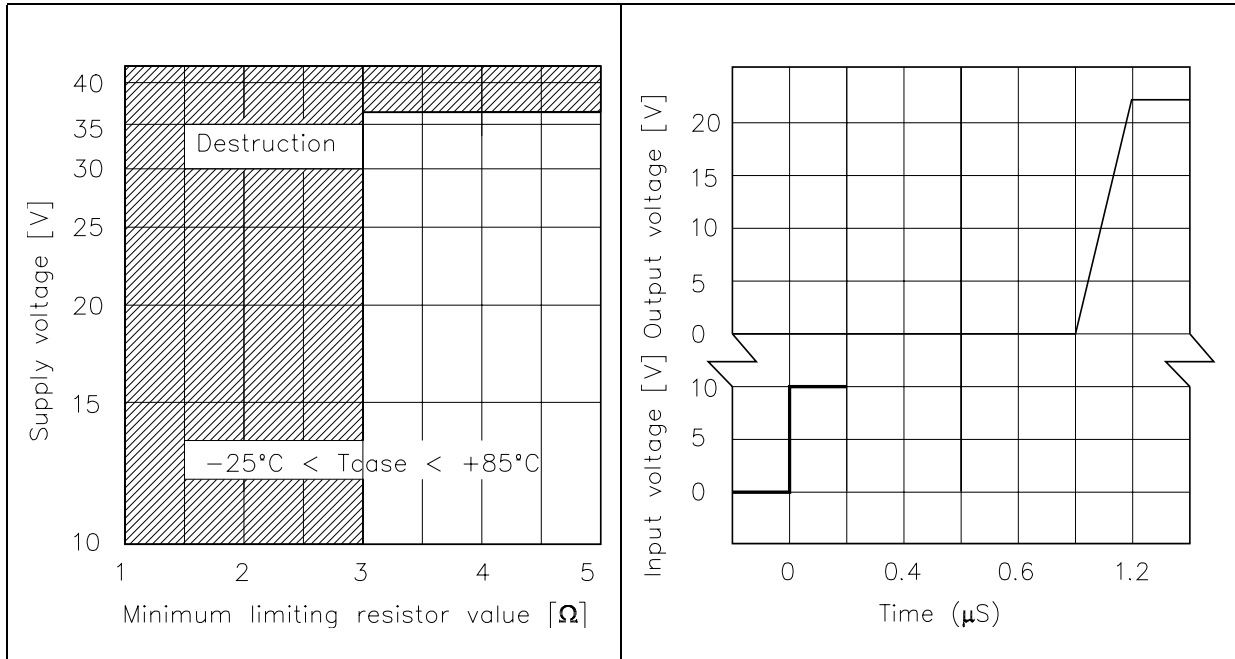
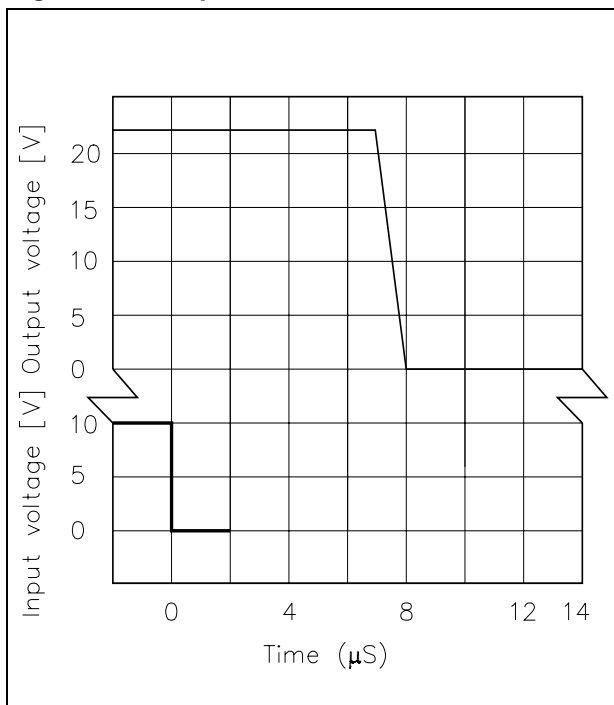

Figure 9. Response time



4 Application circuit

Figure 10. Basic application circuit

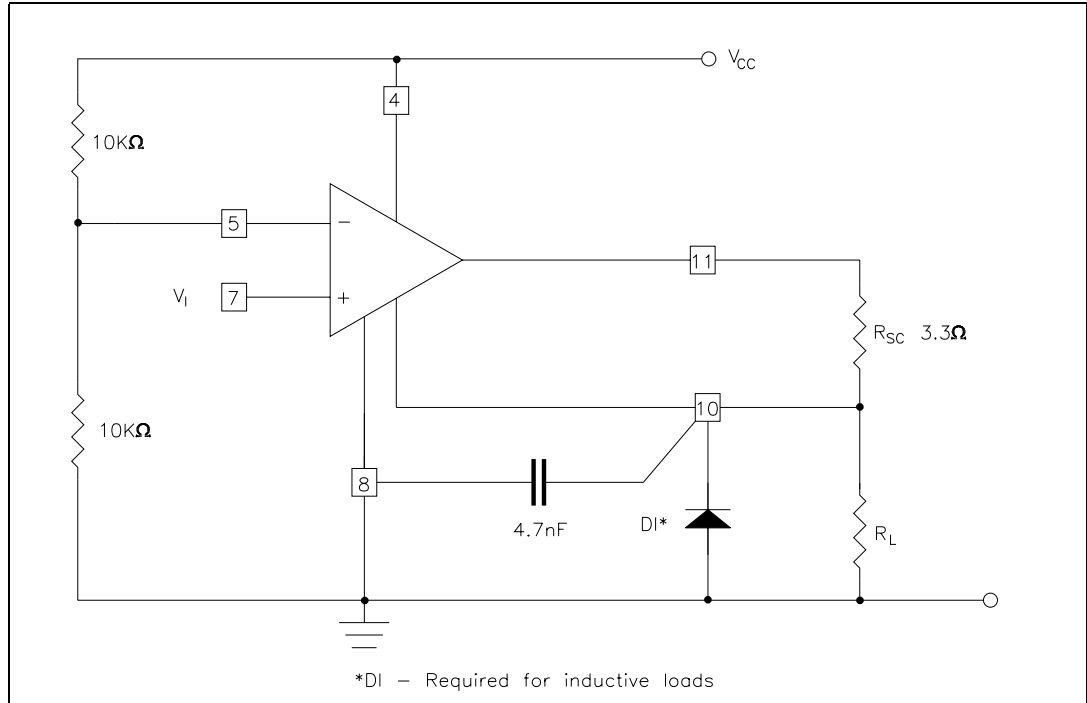
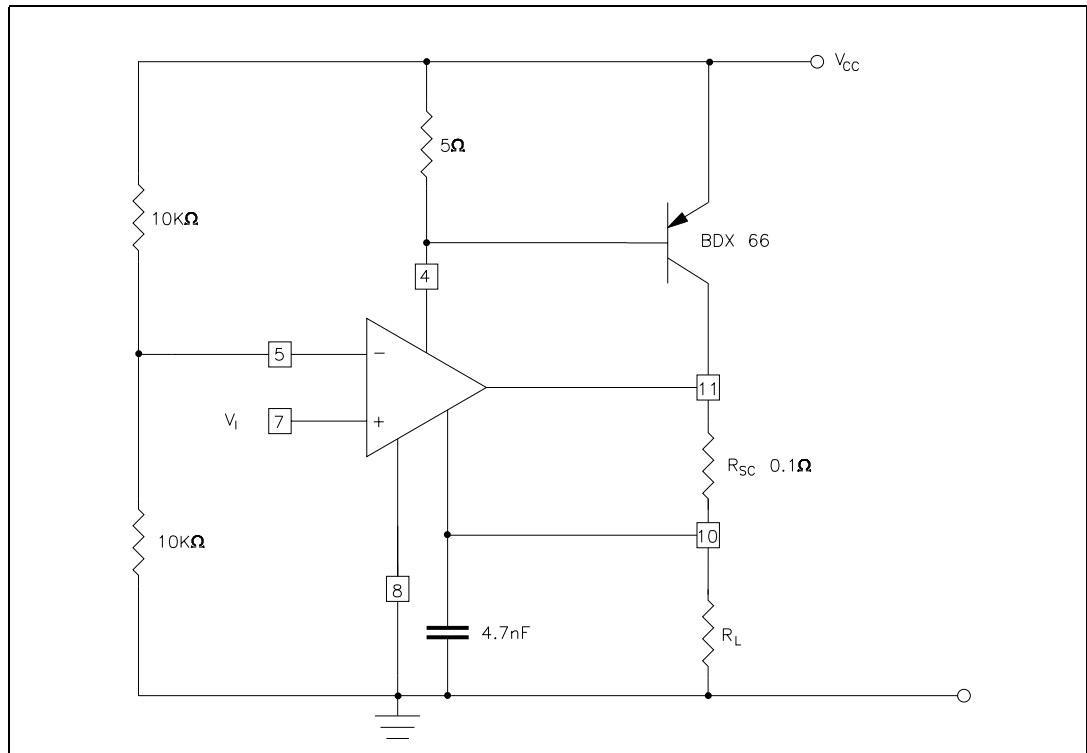

Figure 11. Output current boosting (5A)



5 Package mechanical data

In order to meet environmental requirements, ST offers these devices in ECOPACK® packages. These packages have a Lead-free second level interconnect. The category of second level interconnect is marked on the package and on the inner box label, in compliance with JEDEC Standard JESD97. The maximum ratings related to soldering conditions are also marked on the inner box label. ECOPACK is an ST trademark. ECOPACK specifications are available at: www.st.com

Table 4. SO-14 Mechanical data

Dim.	mm.			inch		
	Min.	Typ	Max.	Min.	Typ.	Max.
A			1.75			0.068
a1	0.1		0.2	0.003		0.007
a2			1.65			0.064
b	0.35		0.46	0.013		0.018
b1	0.19		0.25	0.007		0.010
C		0.5			0.019	
c1	45° (typ.)					
D	8.55		8.75	0.336		0.344
E	5.8		6.2	0.228		0.244
e		1.27			0.050	
e3		7.62			0.300	
F	3.8		4.0	0.149		0.157
G	4.6		5.3	0.181		0.208
L	0.5		1.27	0.019		0.050
M			0.68			0.026
S	8° (max.)					

Figure 12. Package dimensions

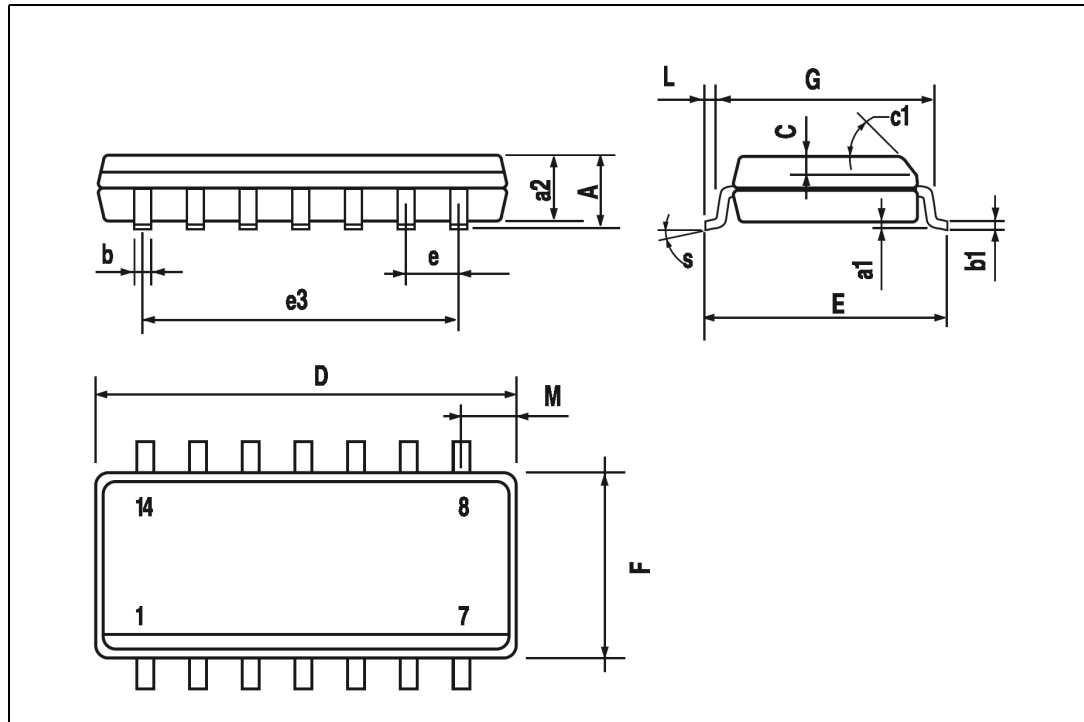

Table 5. Tube shipment information

Tube mechanical data		
	mm.	inch.
A	6.60 ±0.10	0.260 ±0.004
B	1.90 ±0.10	0.075 ±0.004
C	0.60 ±0.10	0.024 ±0.004
D	7.80 ±0.10	0.307 ±0.004
E	4.30 ±0.10	0.169 ±0.004
BASE QUANTITY	100 pcs.	
BULK QUANTITY	2000 pcs.	

Figure 13. Tube dimension

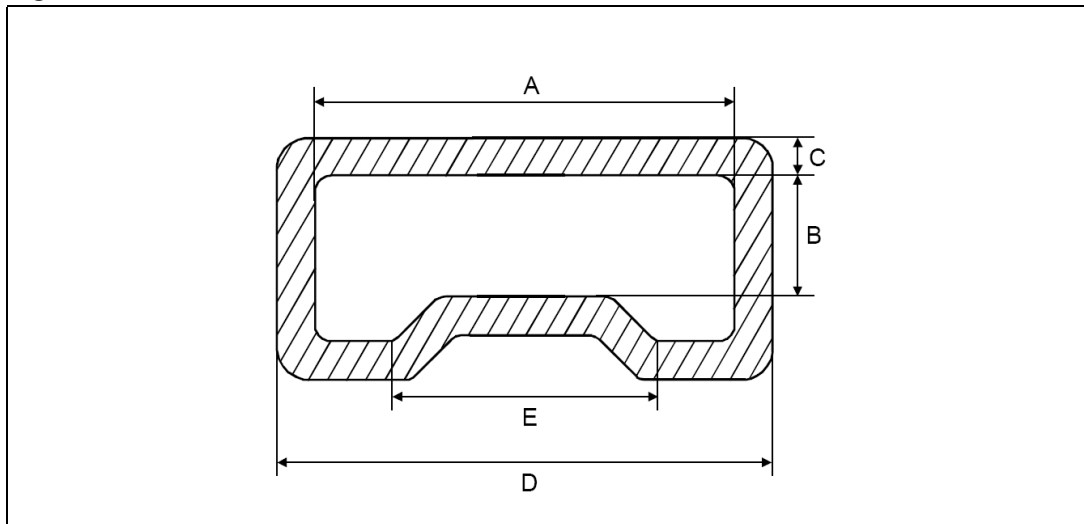

Table 6. Tape & reel shipment information

Tape mechanical data		
	mm.	inch
D	1.50 +0.1/0	0.059 +0.004/0
E	1.75 ±0.1	0.069 ±0.004
Po	4.00 ±0.1	0.157 ±0.004
T max.	0.40	0.016
D1 min.	1.50	0.059
F	7.5 ±0.05	0.295 ±0.002
K max.	6.50	0.256
P2	2.00 ±0.05	0.079 ±0.002
R	40	1.575
W	16.00 ±0.30	0.630 ±0.012
P1	12.00	0.472
Ao, Bo, Ko	0.05 min to 0.90 max.	0.002 min to 0.035 max.

Figure 14. Tape specification

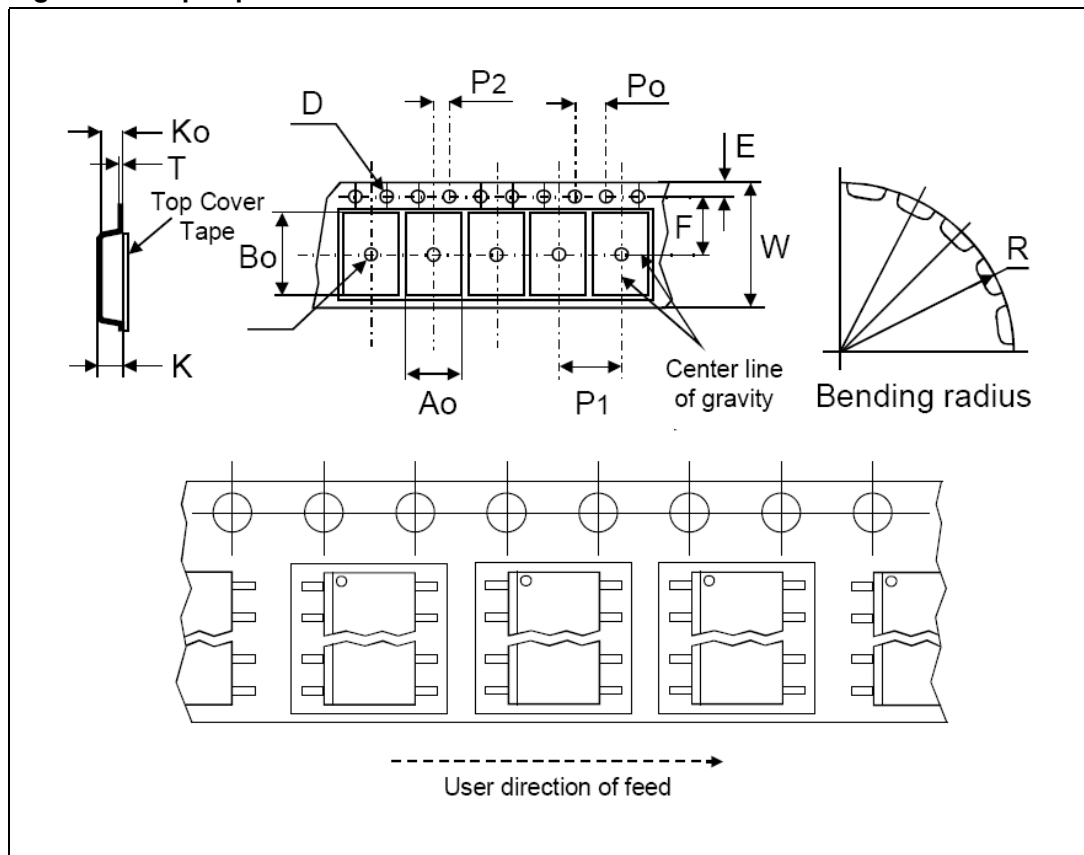
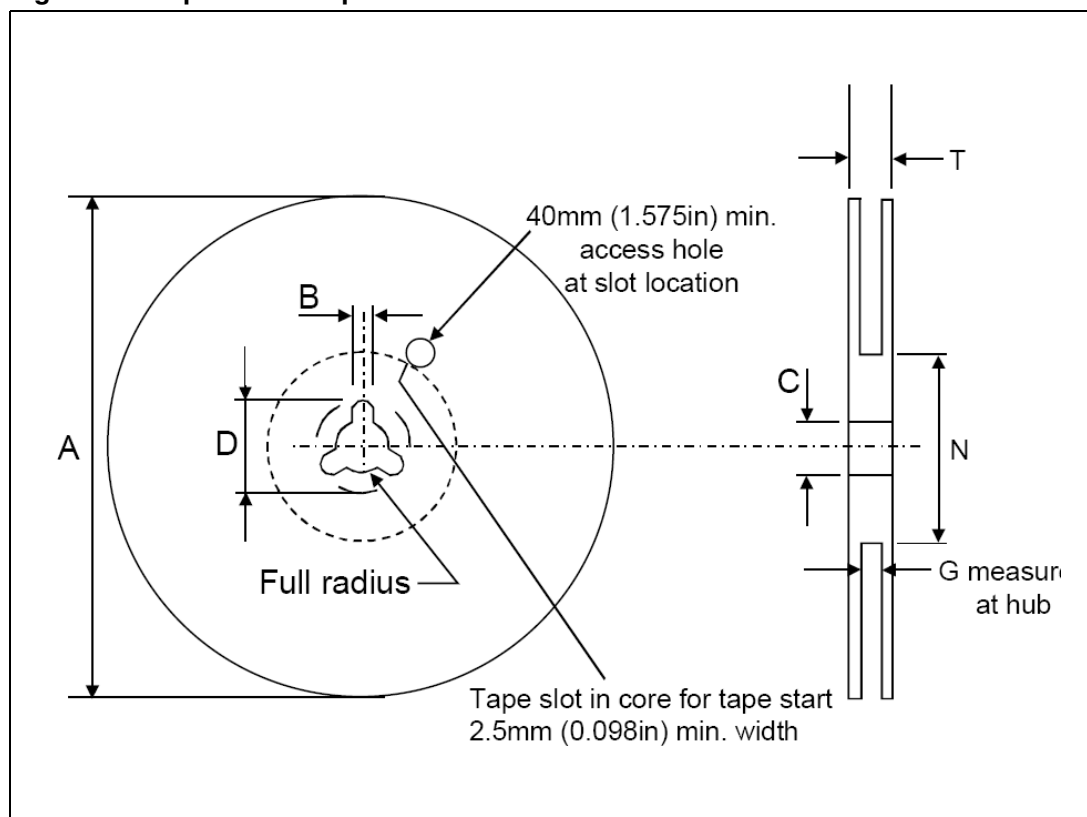

Table 7. Reel mechanical data

	mm.	inch
Tape size	16.0 ±0.30	0.630 ±0.012
A max.	330.0	12.992
B min.	1.5	0.059
C	13.0 ±0.20	0.512 ±0.008
D min.	20.2	0.795
N min.	60	2.362
G	16.4 +2/-0	0.646 +0.079/-0
T max.	22.4	0.882

Figure 15. Tape & reel shipment information



6 Revision history

Table 8. Revision history

Date	Revision	Changes
20-Apr-2006	1	First release
27-Jun-2006	2	Typo in cover page

Please Read Carefully:

Information in this document is provided solely in connection with ST products. STMicroelectronics NV and its subsidiaries ("ST") reserve the right to make changes, corrections, modifications or improvements, to this document, and the products and services described herein at any time, without notice.

All ST products are sold pursuant to ST's terms and conditions of sale.

Purchasers are solely responsible for the choice, selection and use of the ST products and services described herein, and ST assumes no liability whatsoever relating to the choice, selection or use of the ST products and services described herein.

No license, express or implied, by estoppel or otherwise, to any intellectual property rights is granted under this document. If any part of this document refers to any third party products or services it shall not be deemed a license grant by ST for the use of such third party products or services, or any intellectual property contained therein or considered as a warranty covering the use in any manner whatsoever of such third party products or services or any intellectual property contained therein.

UNLESS OTHERWISE SET FORTH IN ST'S TERMS AND CONDITIONS OF SALE ST DISCLAIMS ANY EXPRESS OR IMPLIED WARRANTY WITH RESPECT TO THE USE AND/OR SALE OF ST PRODUCTS INCLUDING WITHOUT LIMITATION IMPLIED WARRANTIES OF MERCHANTABILITY, FITNESS FOR A PARTICULAR PURPOSE (AND THEIR EQUIVALENTS UNDER THE LAWS OF ANY JURISDICTION), OR INFRINGEMENT OF ANY PATENT, COPYRIGHT OR OTHER INTELLECTUAL PROPERTY RIGHT.

UNLESS EXPRESSLY APPROVED IN WRITING BY AN AUTHORIZED REPRESENTATIVE OF ST, ST PRODUCTS ARE NOT DESIGNED, AUTHORIZED OR WARRANTED FOR USE IN MILITARY, AIR CRAFT, SPACE, LIFE SAVING, OR LIFE SUSTAINING APPLICATIONS, NOR IN PRODUCTS OR SYSTEMS, WHERE FAILURE OR MALFUNCTION MAY RESULT IN PERSONAL INJURY, DEATH, OR SEVERE PROPERTY OR ENVIRONMENTAL DAMAGE.

Resale of ST products with provisions different from the statements and/or technical features set forth in this document shall immediately void any warranty granted by ST for the ST product or service described herein and shall not create or extend in any manner whatsoever, any liability of ST.

ST and the ST logo are trademarks or registered trademarks of ST in various countries.

Information in this document supersedes and replaces all information previously supplied.

The ST logo is a registered trademark of STMicroelectronics. All other names are the property of their respective owners.

© 2006 STMicroelectronics - All rights reserved

STMicroelectronics group of companies

Australia - Belgium - Brazil - Canada - China - Czech Republic - Finland - France - Germany - Hong Kong - India - Israel - Italy - Japan - Malaysia - Malta - Morocco - Singapore - Spain - Sweden - Switzerland - United Kingdom - United States of America

www.st.com

Данный компонент на территории Российской Федерации

Вы можете приобрести в компании MosChip.

Для оперативного оформления запроса Вам необходимо перейти по данной ссылке:

<http://moschip.ru/get-element>

Вы можете разместить у нас заказ для любого Вашего проекта, будь то серийное производство или разработка единичного прибора.

В нашем ассортименте представлены ведущие мировые производители активных и пассивных электронных компонентов.

Нашей специализацией является поставка электронной компонентной базы двойного назначения, продукции таких производителей как XILINX, Intel (ex.ALTERA), Vicor, Microchip, Texas Instruments, Analog Devices, Mini-Circuits, Amphenol, Glenair.

Сотрудничество с глобальными дистрибьюторами электронных компонентов, предоставляет возможность заказывать и получать с международных складов практически любой перечень компонентов в оптимальные для Вас сроки.

На всех этапах разработки и производства наши партнеры могут получить квалифицированную поддержку опытных инженеров.

Система менеджмента качества компании отвечает требованиям в соответствии с ГОСТ Р ИСО 9001, ГОСТ РВ 0015-002 и ЭС РД 009

Офис по работе с юридическими лицами:

105318, г.Москва, ул.Щербаковская д.3, офис 1107, 1118, ДЦ «Щербаковский»

Телефон: +7 495 668-12-70 (многоканальный)

Факс: +7 495 668-12-70 (доб.304)

E-mail: info@moschip.ru

Skype отдела продаж:

moschip.ru

moschip.ru_4

moschip.ru_6

moschip.ru_9