

Product Specification

SFP+ Bail and Latch Assembly

PRODUCT FEATURES

- US patent # 7,351,090
- Bail and latch for SFP+ applications
- Various Bail Color options:
 - Black
 - Blue
 - White
 - Orange
 - Beige
 - Red
 - Brown
 - Green
 - Grey

These parts are designed to provide the latching and release mechanism for pluggable SFP+ modules.

Advanced Optical Components, a division of Finisar Corp., offers the bail and the latch as piece parts for external sale to module manufacturers for use within their particular modules. The bail is available in various colors.

This datasheet provides the mechanical dimensions of the bail and the latch, the material information for the bail and the latch as well as interface directions.

PRODUCT SELECTION

Part Number	Description
FTA-BL-SFP+/BLK	BAIL, LF, SFP+, SHEET METAL BASED, BLACK
FTA-BL-SFP+/BLU	BAIL, LF, SFP+, SHEET METAL BASED, BLUE
FTA-BL-SFP+/BGE	BAIL, LF, SFP+, SHEET METAL BASED, BEIGE
FTA-BL-SFP+/ORG	BAIL, LF, SFP+, SHEET METAL BASED, ORANGE
FTA-BL-SFP+/WHT	BAIL, LF, SFP+, SHEET METAL BASED, WHITE
FTA-BL-SFP+/RED	BAIL, LF, SFP+, SHEET METAL BASED, RED
FTA-BL-SFP+/BRW	BAIL, LF, SFP+, SHEET METAL BASED, BROWN
FTA-BL-SFP+/GRN	BAIL, LF, SFP+, SHEET METAL BASED, GREEN
FTA-BL-SFP+/GRY	BAIL, LF, SFP+, SHEET METAL BASED, GREY
FTA-BL-SFP+/YLO	BAIL, LF, SFP+, SHEET METAL BASED, YELLOW
FTA-LT-SFP+	LATCH, SFP+

SFP+ Bail Assembly



SFP+ Latch Assembly



- NOTE: UNLESS OTHERWISE SPECIFIED
 1. MATERIAL: ZINC ALLOY NO.3 PER ASTM B86-88.
 2. FINISH:
 2.1 N PLATE
 2.2 CU UNDERPLATE REQUIRED OVER BASE MATERIAL.
 2.3 ALL DIMENSIONS APPLY AFTER PLATING. PLATING THICKNESS INSPECTION POINTS ARE IDENTIFIED WITH A TRIANGLE.
 3. ALL INTERNAL RADI R0.13mm MAX. CORNER RADI SHALL BE 0.13mm MAX.
 4. MAX DRAFT SHALL BE 1°. ALL DRAFT SHALL BE APPLIED SUCH THAT THE LIMITS OF SIZE NOTED ARE HELD AT THE SURFACES INDICATED.
 5. GATES AND EJECTORS:
 6.1 EJECTOR MARKS SHALL NOT CAUSE ANY FEATURE TO BE OUT OF ITS SPECIFIED LIMITS OF SIZE OR LOCATION.
 6.2 STA INTERSECTING LINE FLASH AND GATE VESTAGE TO BE 0.05mm HIGH MAX.
 7. CRITICAL SURFACE DIMENSIONS OR PARAMETERS.
 8.1 CRITICAL TO FUNCTION DIMENSIONS ARE IDENTIFIED WITH AN INSPECTION BUBBLE.

UNLESS OTHERWISE SPECIFIED:
 DIMENSIONS ARE IN MILLIMETERS
 TOLERANCES ARE:
 .XX ± .2
 .XXX ± .10
 .XXXX ± .050
 .XXXXX ± .0250
 ANGLES ± 1 DEG.

SFP+ Shell Geometr

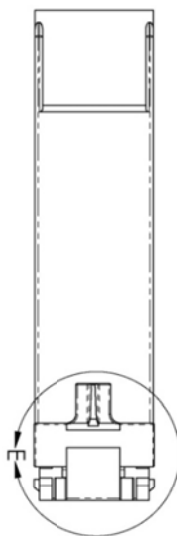
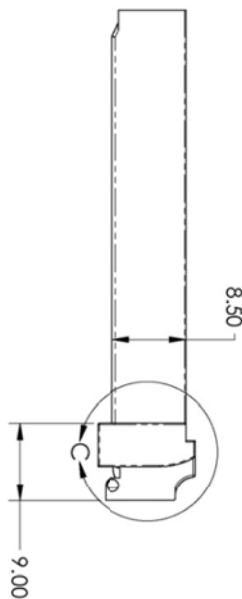
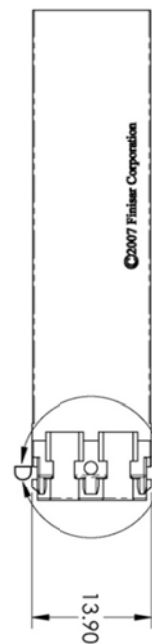
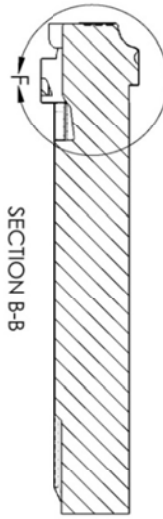

- NOTE: UNLESS OTHERWISE SPECIFIED
 1. MATERIAL: ZINC ALLOY (NO.3 PER ASTM B86-88).
 2. FINISH:
 2.1. Ni PLATE
 2.2. CU UNDERPLATE REQUIRED OVER BASE MATERIAL.
 2.3. ALL DIMENSIONS APPLY AFTER PLATING. PLATING THICKNESS INSPECTION POINTS ARE IDENTIFIED WITH A TRIANGLE.
 3. ALL INTERNAL RADII SHALL BE 0.13mm MAX. CORNER RADII SHALL BE 0.13mm MAX.
 4. MAX DRAFT SHALL BE 1°. ALL DRAFT SHALL BE APPLIED SUCH THAT THE LIMITS OF SIZE NOTED ARE HELD AT THE SURFACES INDICATED.
 6. GATES AND EJECTORS:
 6.1 EJECTOR MARKS SHALL NOT CAUSE ANY FEATURE TO BE OUT OF ITS SPECIFIED LIMITS OF SIZE OR LOCATION.
 6.2 STANDING PARTING LINE FLASH AND GATE VESTAGE TO BE 0.05mm HIGH MAX.
 7. CRITICAL INTERFACE DIMENSIONS OR PARAMETERS.
 8.1 CRITICAL TO FUNCTION DIMENSIONS ARE IDENTIFIED WITH AN INSPECTION BUBBLE.

SFP+ Bail Shell Geometry

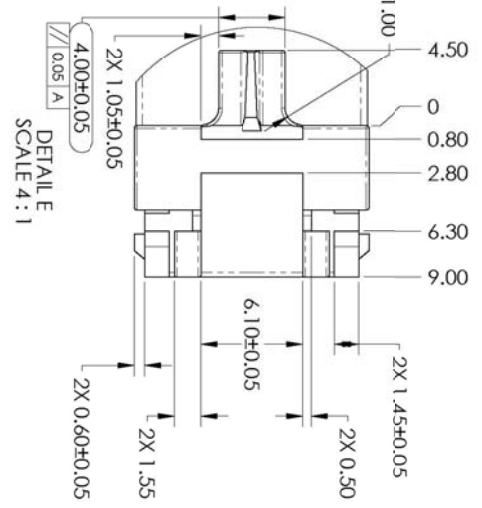
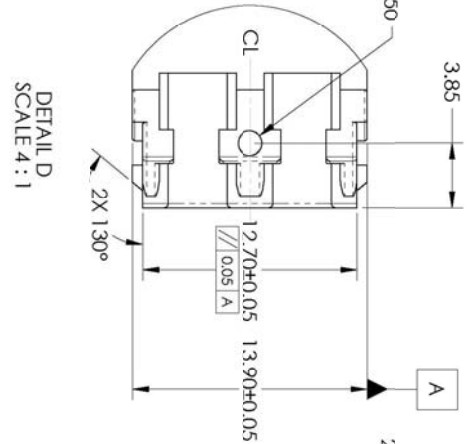
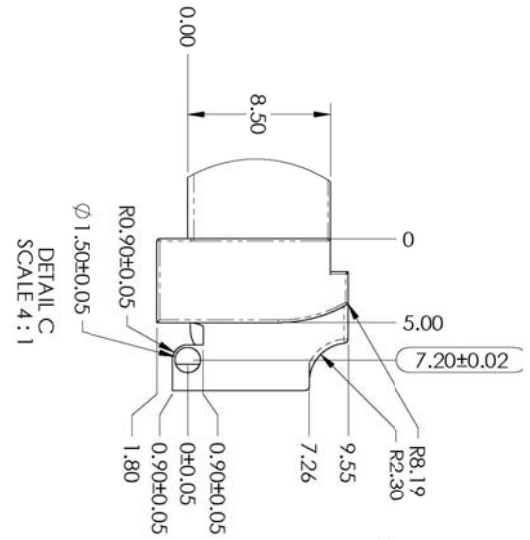
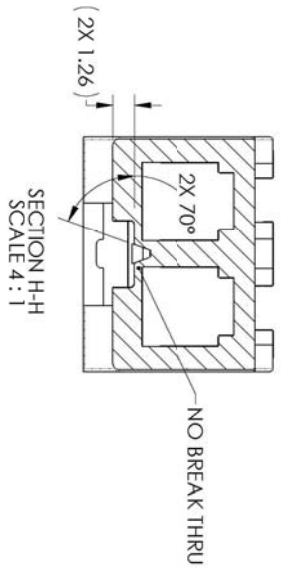
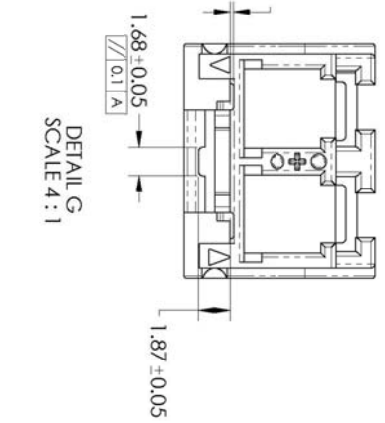

SFP+ BAIL – SHEET METAL



SFP+ BAIL – PAINT TRANSFER DECAL

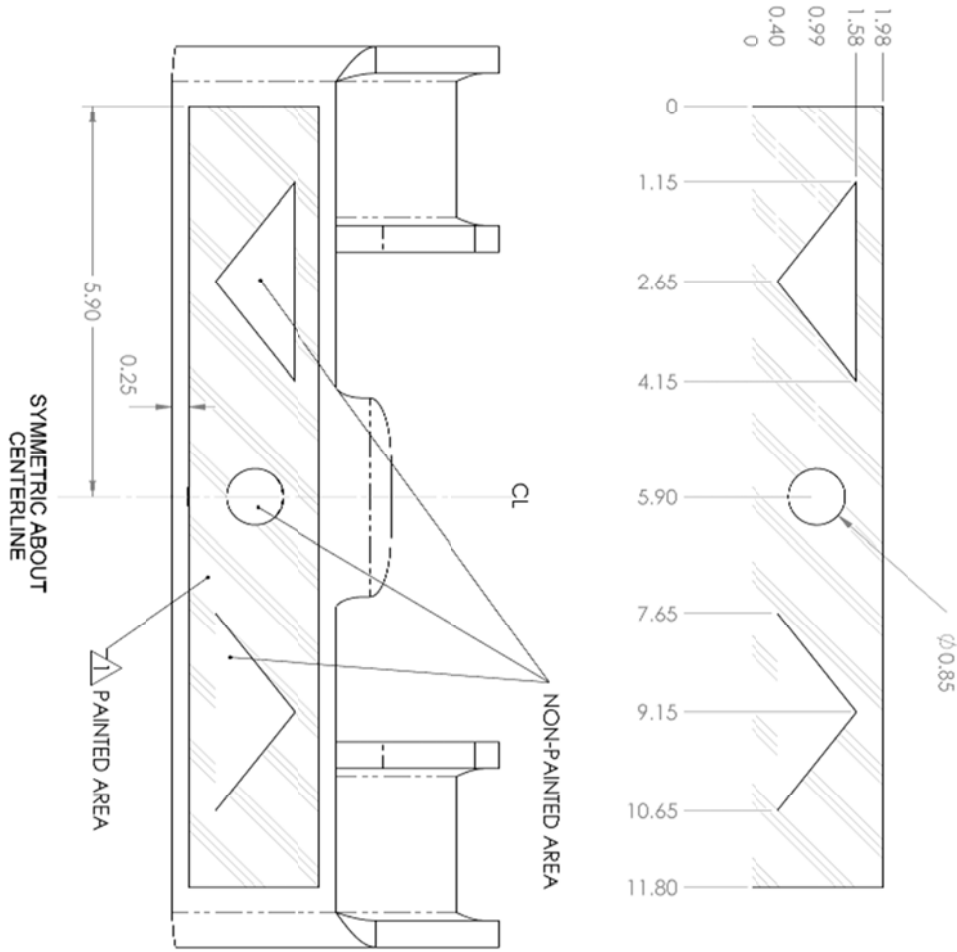

NOTES:
 /A SURFACE MUST BE FREE FROM SCRATCHES, DERRIS, AND OTHER CONTAMINANTS.

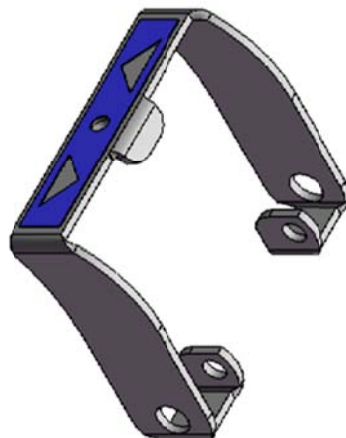

Assembly Instructions



Revision History

Revision	Date	Description
N	4/13/2013	• Finisar Datasheet format

XII. For More Information

Finisar Corporation
1389 Moffett Park Drive
Sunnyvale, CA 94089-1133
Tel. 1-408-548-1000
Fax 1-408-541-6138
sales@finisar.com
www.finisar.com

Данный компонент на территории Российской Федерации

Вы можете приобрести в компании MosChip.

Для оперативного оформления запроса Вам необходимо перейти по данной ссылке:

<http://moschip.ru/get-element>

Вы можете разместить у нас заказ для любого Вашего проекта, будь то серийное производство или разработка единичного прибора.

В нашем ассортименте представлены ведущие мировые производители активных и пассивных электронных компонентов.

Нашей специализацией является поставка электронной компонентной базы двойного назначения, продукции таких производителей как XILINX, Intel (ex.ALTERA), Vicor, Microchip, Texas Instruments, Analog Devices, Mini-Circuits, Amphenol, Glenair.

Сотрудничество с глобальными дистрибьюторами электронных компонентов, предоставляет возможность заказывать и получать с международных складов практически любой перечень компонентов в оптимальные для Вас сроки.

На всех этапах разработки и производства наши партнеры могут получить квалифицированную поддержку опытных инженеров.

Система менеджмента качества компании отвечает требованиям в соответствии с ГОСТ Р ИСО 9001, ГОСТ РВ 0015-002 и ЭС РД 009

Офис по работе с юридическими лицами:

105318, г.Москва, ул.Щербаковская д.3, офис 1107, 1118, ДЦ «Щербаковский»

Телефон: +7 495 668-12-70 (многоканальный)

Факс: +7 495 668-12-70 (доб.304)

E-mail: info@moschip.ru

Skype отдела продаж:

moschip.ru

moschip.ru_4

moschip.ru_6

moschip.ru_9