

MPB125 Single-Output AC-DC Series



The MPB125 Series incorporates patented high efficiency circuitry, high power density and active Power Factor Correction (PFC) to meet the requirements of networking and data communications systems, as well as commercial and industrial configurations.

MPB125 single-output models deliver a fully-regulated output. The MPB125 is rated for convection as well as forced air cooling. Full output power is available with as few as 5 Cubic Feet per Minute (CFM) forced-air cooling.

The MPB125 product line is approved to the latest international regulatory standards and displays the CE Mark.

Key Features & Benefits

- RoHS Compliant
- High Power Density
- Industry-Standard 3" x 5" Footprint
- Power Factor Correction (PFC) meets EN61000-3-2
- CE Marked to Low Voltage Directive (Pending)
- Input Transient & ESD Compliance to EN61000-4-2/-3/-4/-5
- MTBF In Excess of 1 Million Hours
- Output Adjustment Potentiometer

North America

+1-866.513.2839

Asia-Pacific

+86.755.29885888

Europe, Middle East

+353 61 225 977

tech.support@psbel.com
belpowersolutions.com

MPB125 Single-Output AC-DC Series

Single Output Model Selection

MODEL	OUTPUT VOLTAGE [V]	MAXIMUM OUTPUT CURRENT (AMPS), 130 LFM	TOTAL REGULATION [%]	RIPPLE & NOISE ¹ % pk-pk	ADJUSTMENT RANGE
MPB125-1012G ^{2,3}	12V	10.5A	±1%	1%	11.76 to 12.24V

NOTES:

- ¹ Maximum peak-to-peak noise expressed as a percentage of output voltage, 20 MHz bandwidth.
- ² Maximum forced-air output power is 125 watts with 5 CFM airflow.
- ³ Maximum convection output power is 70 watts.

Input Specifications

PARAMETER	CONDITIONS/DESCRIPTION	MIN	NOM	MAX	UNITS
Input Voltage- AC	Continuous input range	90		264	VAC
Input Frequency	AC Input	47		63	Hz
Brownout Protection	Lowest AC input voltage that regulation is maintained with full rated loads	90			VAC
Hold-up Time	Over full AC input voltage range at full rated load	17			ms
Input Current	90 VAC at full rated load			1.8	A _{RMS}
Input Protection	Non-user serviceable internally located AC input line fuse, 3.15A				
Inrush Surge Current	Internally limited by thermistor, one cycle, 25°C			110VAC: 220VAC:	23 46 A _{PK}
Power Factor Circuitry	Active PFC meets requirements of EN61000-3-2				
Operating Frequency	Switching frequency of main transformer		45		kHz

Output Specifications

PARAMETER	CONDITIONS/DESCRIPTION	MIN	NOM	MAX	UNITS
Efficiency	Full Load, 230VAC		80		%
Minimum Loads	No Minimum Load is Required				Amps
Ripple and Noise	Full load, 20 MHz bandwidth		See Model Selection Chart		
Output Power (Note 1)	At 5 CFM forced-air cooling. See Application Note #M3 for details Convection:			125 70	Watts
Overshoot /Undershoot	Output voltage overshoot/undershoot at turn-on.			10	%
Regulation	Varies by output. Total regulation includes: line changes from 85-132 VAC or 170-264 VAC, changes in load starting at 20% load and changing to 100% load		See Model Selection Chart		
Transient Response	Maximum deviation due to a 25% load change with unit at 75% load		3		%
Turn-on Delay	Time required for initial output voltage stabilization	0.2		1.5	Sec
Turn-on Rise Time	Time required for output voltage to rise from 10% to 90%	0.2		20	ms

MPB125 Single-Output AC-DC Series

Interface Signals and Internal Protection

PARAMETER	CONDITIONS/DESCRIPTION	MIN	NOM	MAX	UNITS
Overvoltage Protection	MPB125-1012G	13.5		16.5	VDC
Overload Protection	Fully protected against output short circuit or overload Automatic recovery upon removal of overload condition				
Thermal Shutdown	Protected against overtemperature conditions Unit recovers when overtemperature condition is removed				

Safety, Regulatory, and EMI Specifications

PARAMETER	CONDITIONS/DESCRIPTION	MIN	NOM	MAX	UNITS
Agency Approvals	Approved to latest edition of the following standards: UL/CSA60950-1, IEC60950-1 and EN60950-1.				
Dielectric Withstand Voltage	Input to Chassis	2121			VDC
	Input to Output (Tested by manufacturer only)	4242			VDC
Electromagnetic Interference	EN55022 Conducted	B			Class
ESD Susceptibility	Per EN61000-4-2, Level 4	8			kV
Flicker	Per EN61000-3-3				
Radiated Susceptibility	Per EN61000-4-3		3		V/m
EFT/Burst	Per EN61000-4-4	1			kV
Input Transient Protection	Per EN61000-4-5, Level 3, 2 kV (Line-to-Ground) minimum, 1 kV (Line-to-Line) minimum.				
RF Immunity	Per EN61000-4-6. 0.15 to 80 MHz (1 kHz sine wave)		3		V/m
Magnetic Fields	Per EN61000-4-8		1		A/m
Voltage Dips	Per EN61000-4-11				
Insulation Resistance	Input to output		10		MΩ
Leakage Current	Per EN60950 (264 VAC)			1.0	mA

Environmental Specifications

PARAMETER	CONDITIONS/DESCRIPTION	MIN	NOM	MAX	UNITS
Altitude	Operating			10K	ASL Feet
	Non-Operating			50K	
Operating Temperature	Derate linearly from 50 to 70°C to 50% power at 70°C At 100% I	0		50	°C
Storage Temperature		-40		85	°C
Forced-Air Cooling	Forced-air cooling of 5 CFM is required for full output power. Air velocity is measured with power supply mounted on 0.375" (9.5mm) standoffs. Airflow direction is from the input section to the output section. See Application Note for details.				
Temperature Coefficient	Included in total regulation of outputs				
Relative Humidity	Non-Condensing	5		95	%RH
Shock	Operating: 11 ±3ms, 3 axes, Half Sine			15	Gpk
	Non-operating: 11 ±3ms, 3 axes, Half Sine			40	
Vibration	Operating: Random vibration, 5-500 Hz, 10 minutes each axis			2.4	G _{RMS}
	Non-Operating: Random vibration, 5-500 Hz, 10 minutes each axis			6.0	

MPB125 Single-Output AC-DC Series

Figure 1 - Mechanical Drawing (MPB125-1012G Model)

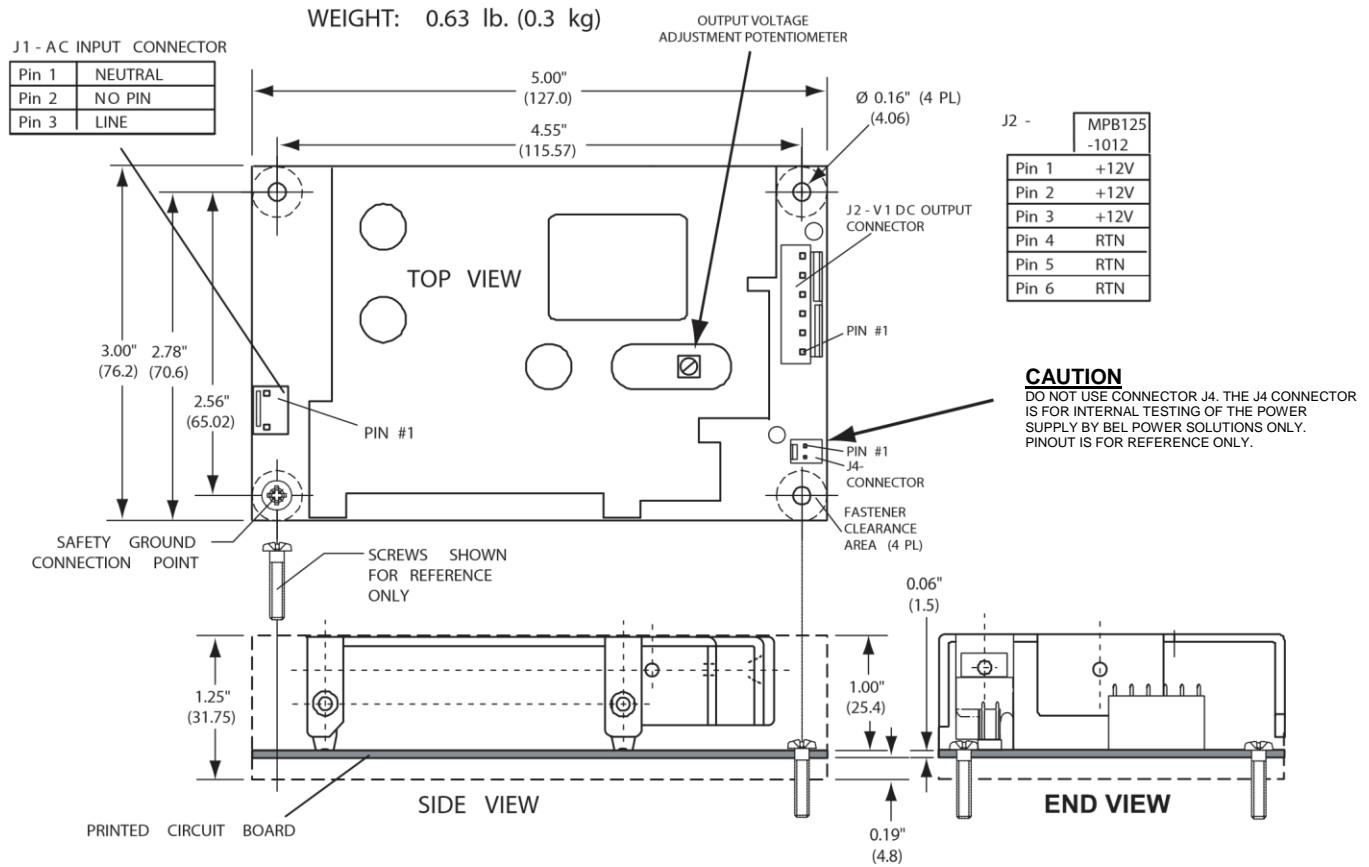

Mating Connectors

MPB125-1012G		
J1	Housing	09-50-8033
	Pins	08-52-0113
J1	Housing	09-50-8063
	Pins	08-52-0113

NOTE: Part numbers are MOLEX; equivalents are acceptable.

For more information on these products consult: tech.support@psbel.com

NUCLEAR AND MEDICAL APPLICATIONS - Products are not designed or intended for use as critical components in life support systems, equipment used in hazardous environments, or nuclear control systems.

TECHNICAL REVISIONS - The appearance of products, including safety agency certifications pictured on labels, may change depending on the date manufactured. Specifications are subject to change without notice.

Данный компонент на территории Российской Федерации

Вы можете приобрести в компании MosChip.

Для оперативного оформления запроса Вам необходимо перейти по данной ссылке:

<http://moschip.ru/get-element>

Вы можете разместить у нас заказ для любого Вашего проекта, будь то серийное производство или разработка единичного прибора.

В нашем ассортименте представлены ведущие мировые производители активных и пассивных электронных компонентов.

Нашей специализацией является поставка электронной компонентной базы двойного назначения, продукции таких производителей как XILINX, Intel (ex.ALTERA), Vicor, Microchip, Texas Instruments, Analog Devices, Mini-Circuits, Amphenol, Glenair.

Сотрудничество с глобальными дистрибьюторами электронных компонентов, предоставляет возможность заказывать и получать с международных складов практически любой перечень компонентов в оптимальные для Вас сроки.

На всех этапах разработки и производства наши партнеры могут получить квалифицированную поддержку опытных инженеров.

Система менеджмента качества компании отвечает требованиям в соответствии с ГОСТ Р ИСО 9001, ГОСТ РВ 0015-002 и ЭС РД 009

Офис по работе с юридическими лицами:

105318, г.Москва, ул.Щербаковская д.3, офис 1107, 1118, ДЦ «Щербаковский»

Телефон: +7 495 668-12-70 (многоканальный)

Факс: +7 495 668-12-70 (доб.304)

E-mail: info@moschip.ru

Skype отдела продаж:

moschip.ru

moschip.ru_4

moschip.ru_6

moschip.ru_9