

THIS DRAWING IS UNPUBLISHED. RELEASED FOR PUBLICATION 20
 © COPYRIGHT 20 BY - ALL RIGHTS RESERVED.

LOC		DIST		REVISIONS			
P	LTR	DESCRIPTION		DATE	DWN	APVD	
	A4	REVISED PER ECR-13-007047		16MAY2013	RS	DD	
	A5	REVISED PER ECR-15-003564		13MAR2015	RS	DD	
	B	REVISED PER ECR-15-004054		28JUL2015	RS	DD	
	C	REVISED PER ECR-15-017995		18DEC2015	RS	DD	

1 MATERIALS AND FINISH:
 - HOUSING: LCP, COLOR: NATURAL
 - CONTACTS: COPPER ALLOY, FINISH: Sn OVER Ni

2. COMPLY WITH DIRECTIVE 2002/95/EC (ROHS).

3. 18-24AWG SOLID OR STRANDED WIRE.
 PLEASE REFER TO APPLICATION SPEC 114-13266
 FOR RECOMMENDED STRAND COUNT.
 18AWG MAX INSULATION OD: 2.20
 20AWG MAX INSULATION OD: 1.90
 22AWG MAX INSULATION OD: 1.70
 24AWG MAX INSULATION OD: 1.45

4. PACKAGE IN TAPE AND REEL. PER EIA-481 SPECIFICATION;
 (EXCEPT 1 POSITION CONNECTOR).

5 WIRE SIZE MARKING IN APPROXIMATE LOCATION SHOWN.

6 DATUMS AND BASIC DIMENSIONS ESTABLISHED BY CUSTOMER.

7 COLOR CODE MARKING, STRAIGHT LINE.

8 1 POSITION ASSEMBLY DOES NOT COMPLY WITH EIA 481 SPECIFICATION.

COLOR CODE	DIM D	WIRE SIZE	POSN	COLOR	PART NUMBER
RED	17.70	24 AWG	4	BLACK	7-2106003-4
	13.70	24 AWG	3	BLACK	7-2106003-3
	9.70	24 AWG	2	BLACK	7-2106003-2
	5.70	24 AWG	1	BLACK	7-2106003-1
GREEN	17.70	22 AWG	4	BLACK	6-2106003-4
	13.70	22 AWG	3	BLACK	6-2106003-3
	9.70	22 AWG	2	BLACK	6-2106003-2
	5.70	22 AWG	1	BLACK	6-2106003-1
BLUE	17.70	20 AWG	4	BLACK	5-2106003-4
	13.70	20 AWG	3	BLACK	5-2106003-3
	9.70	20 AWG	2	BLACK	5-2106003-2
	5.70	20 AWG	1	BLACK	5-2106003-1
YELLOW	17.70	18 AWG	4	BLACK	4-2106003-4
	13.70	18 AWG	3	BLACK	4-2106003-3
	9.70	18 AWG	2	BLACK	4-2106003-2
	5.70	18 AWG	1	BLACK	4-2106003-1
RED	17.70	24 AWG	4	NATURAL	3-2106003-4
	13.70	24 AWG	3	NATURAL	3-2106003-3
	9.70	24 AWG	2	NATURAL	3-2106003-2
	5.70	24 AWG	1	NATURAL	3-2106003-1
GREEN	17.70	22 AWG	4	NATURAL	2-2106003-4
	13.70	22 AWG	3	NATURAL	2-2106003-3
	9.70	22 AWG	2	NATURAL	2-2106003-2
	5.70	22 AWG	1	NATURAL	2-2106003-1
BLUE	17.70	20 AWG	4	NATURAL	1-2106003-4
	13.70	20 AWG	3	NATURAL	1-2106003-3
	9.70	20 AWG	2	NATURAL	1-2106003-2
	5.70	20 AWG	1	NATURAL	1-2106003-1
YELLOW	17.70	18 AWG	4	NATURAL	2106003-4
	13.70	18 AWG	3	NATURAL	2106003-3
	9.70	18 AWG	2	NATURAL	2106003-2
	5.70	18 AWG	1	NATURAL	2106003-1

THIS DRAWING IS A CONTROLLED DOCUMENT.		DWN C DAILY 09DEC2008	TE Connectivity	
		CHK J DYER 09DEC2008		
DIMENSIONS: mm	TOLERANCES UNLESS OTHERWISE SPECIFIED:	APVD -	NAME ASSEMBLY, IDC SSL CONNECTOR, SMT, CLOSED END	
	0 PLC ± 1 PLC ±0.5 2 PLC ±0.13 3 PLC ± 4 PLC ±	PRODUCT SPEC 108-2404	SIZE A2	
MATERIAL	ANGLES ± FINISH	APPLICATION SPEC 114-13266	CAGE CODE 00779	DRAWING NO C-2106003
		WEIGHT -	RESTRICTED TO -	SCALE 2:1
Customer Drawing			SHEET 1 OF 4	REV C

THIS DRAWING IS UNPUBLISHED. RELEASED FOR PUBLICATION 20
 © COPYRIGHT 20 BY - ALL RIGHTS RESERVED.

LOC		DIST		REVISIONS				
P	LTR	DESCRIPTION			DATE	DWN	APVD	
-	-	SEE SHEET 1			-	-	-	

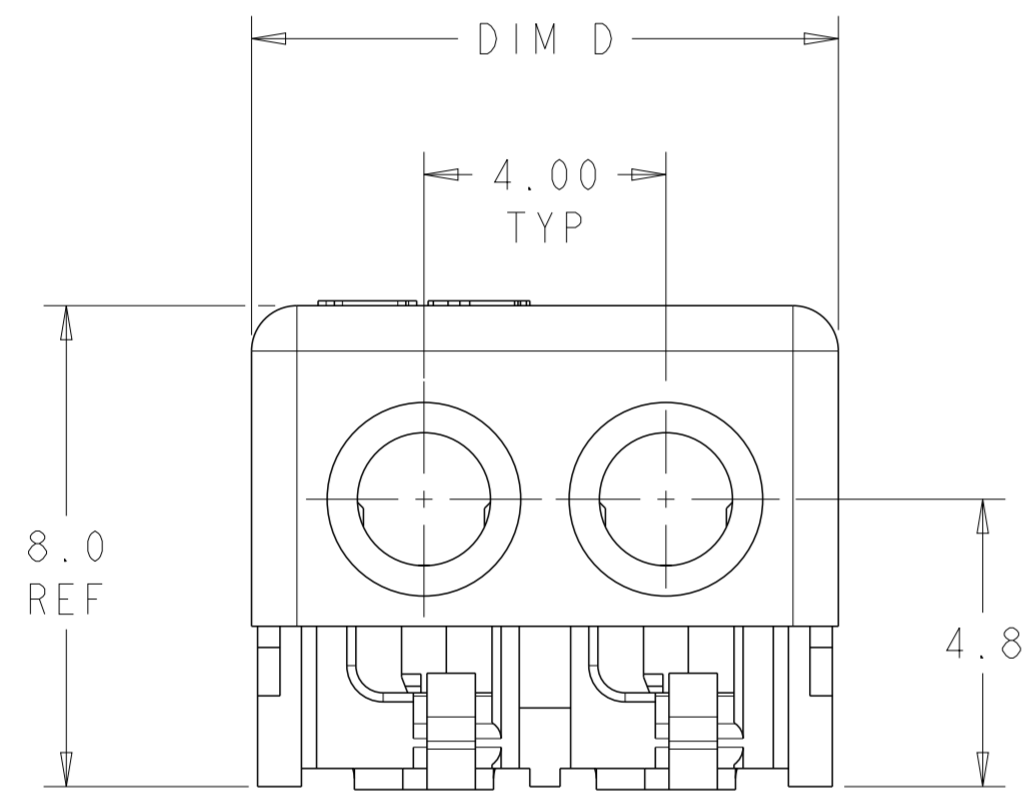
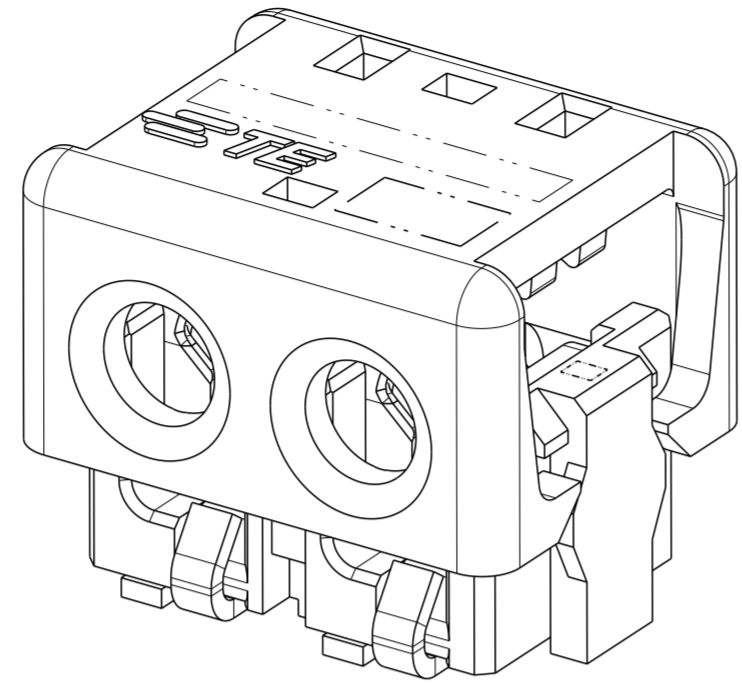
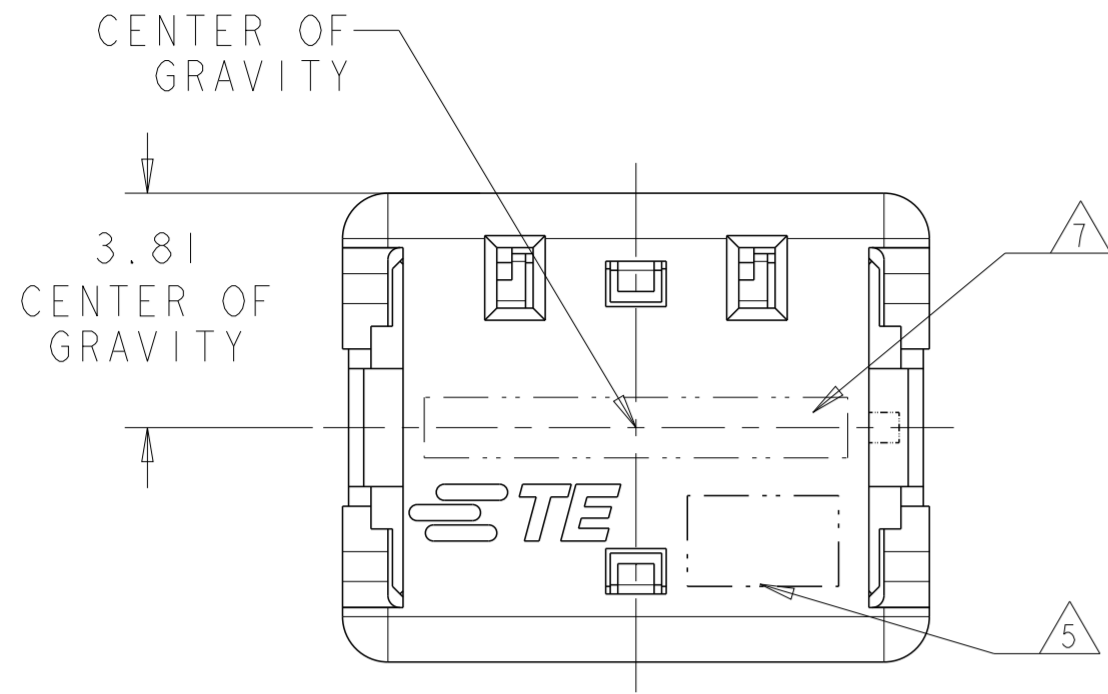

2 POSITION
SHOWN AS SHIPPED

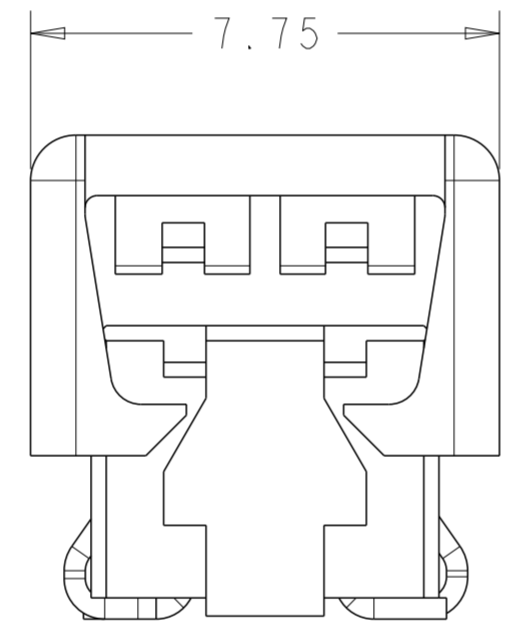

FOR 1 POSITION ONLY

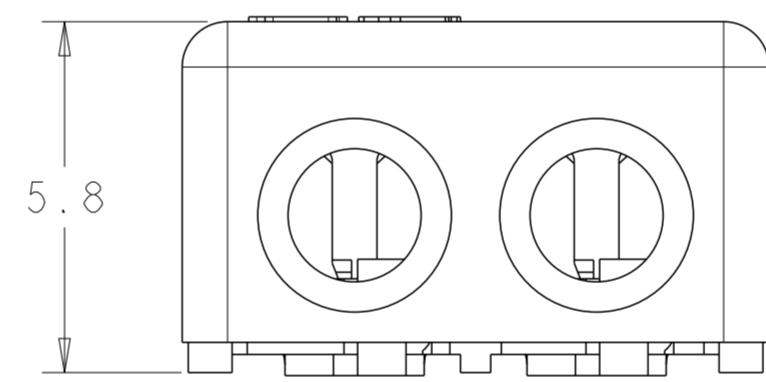

2 POSITION
SHOWN CLOSED
SCALE 8:1

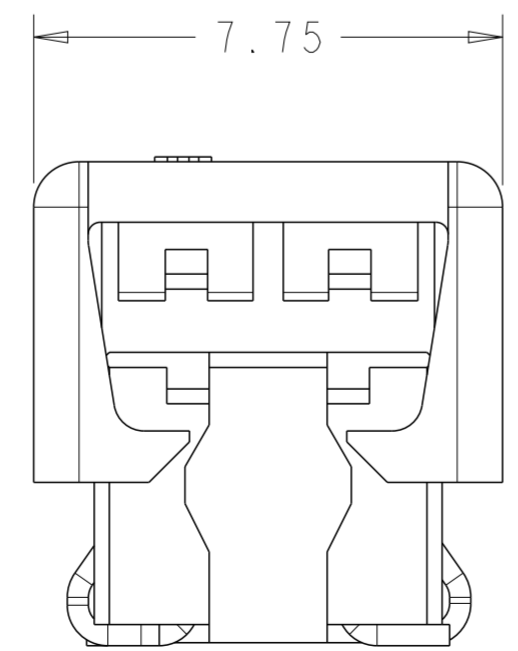

FOR 2, 3 AND 4 POSITIONS

THIS DRAWING IS A CONTROLLED DOCUMENT.		DWN C DAILY 09DEC2008	STE TE Connectivity	
		CHK J DYER 09DEC2008		
DIMENSIONS:		APVD -	NAME ASSEMBLY, IDC SSL CONNECTOR, SMT, CLOSED END	
mm	TOLERANCES UNLESS OTHERWISE SPECIFIED:	PRODUCT SPEC 108-2404	SIZE A2	CAGE CODE 00779
	0 PLC ±	APPLICATION SPEC 114-13266	DRAWING NO C-2106003	RESTRICTED TO -
	1 PLC ±0.5	WEIGHT -	SCALE 2:1	SHEET 1
	2 PLC ±0.13		OF 4	REV C
	3 PLC ±			
	4 PLC ±			
	ANGLES ±			
MATERIAL	FINISH	Customer Drawing		
material_2	finish_spec_2			

THIS DRAWING IS UNPUBLISHED. RELEASED FOR PUBLICATION 20
 © COPYRIGHT 20 BY - ALL RIGHTS RESERVED.

LOC		DIST		REVISIONS				
P	LTR	DESCRIPTION			DATE	DWN	APVD	
-	-	SEE SHEET 1			-	-	-	

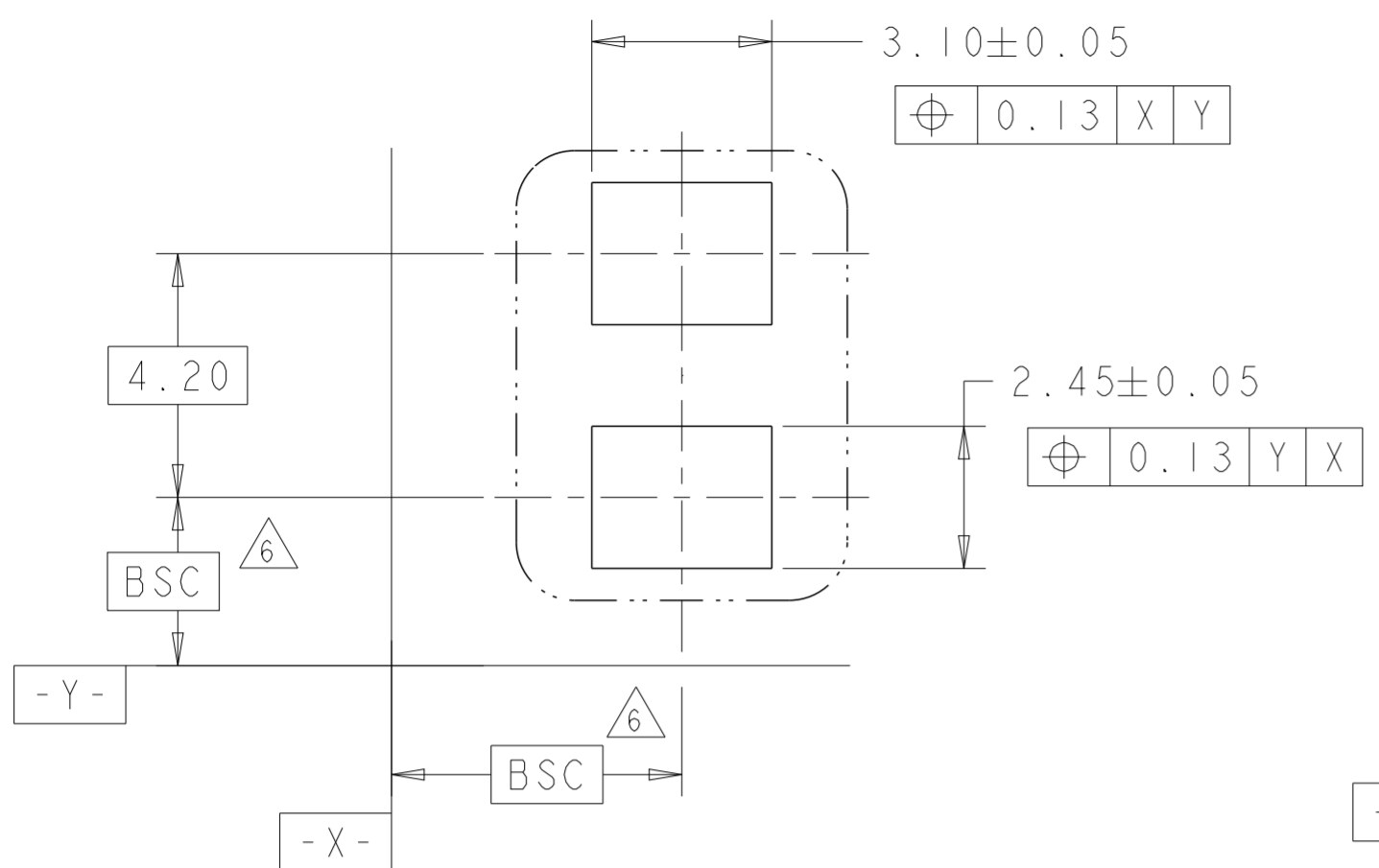

1 POSITION
RECOMMENDED PAD LAYOUT
SCALE 8:1

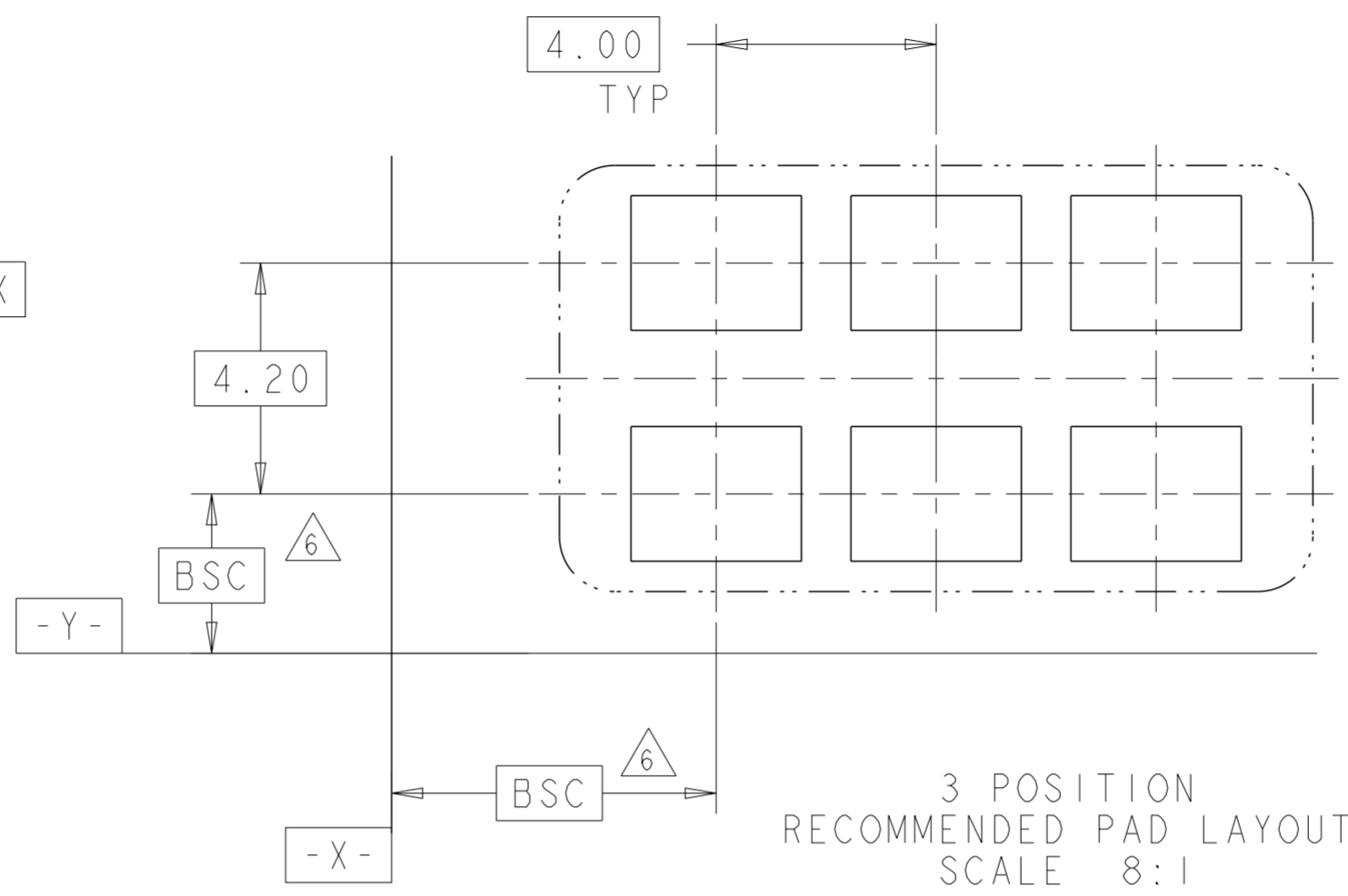

3 POSITION
RECOMMENDED PAD LAYOUT
SCALE 8:1

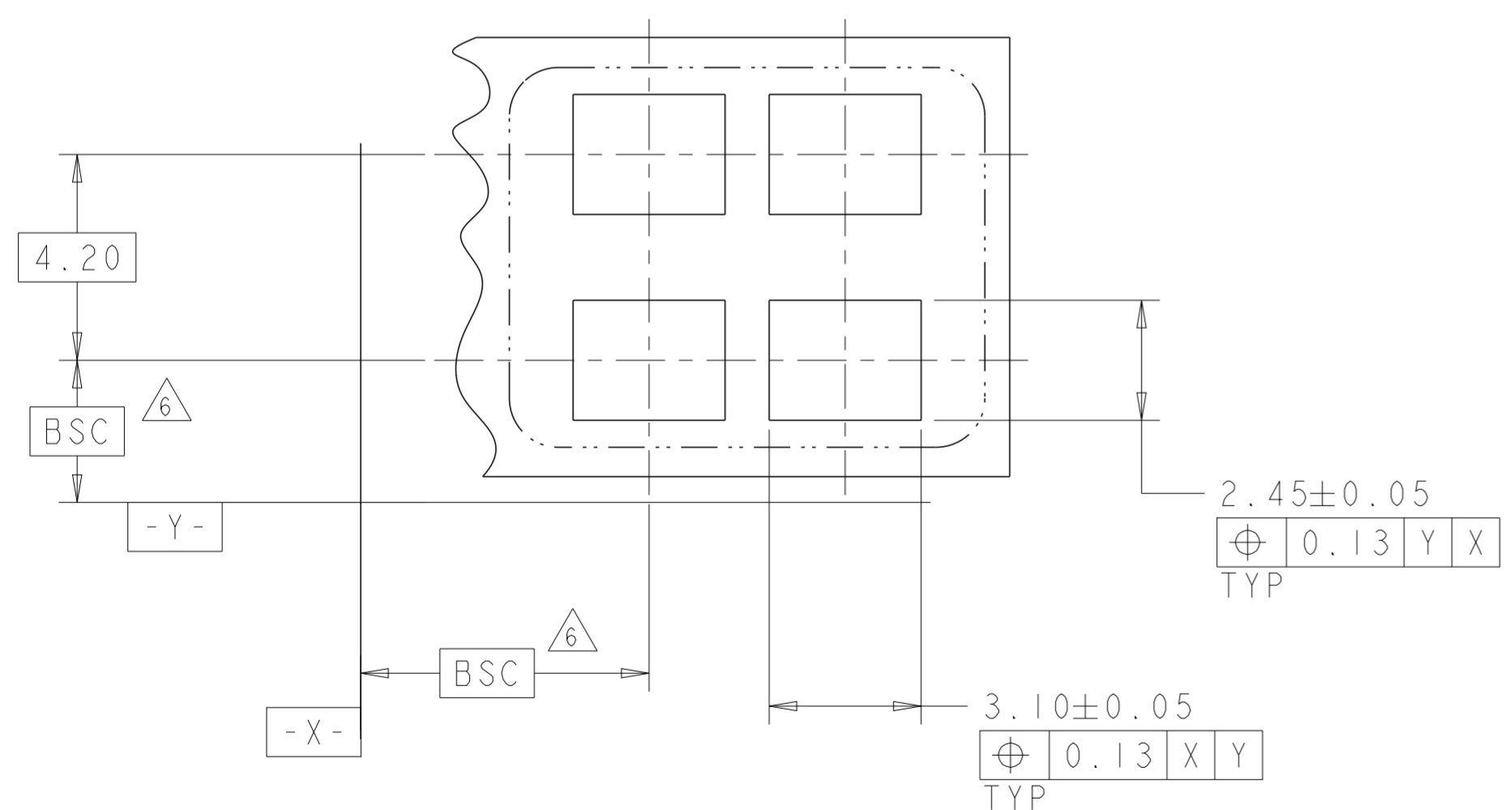

2 POSITION
RECOMMENDED PAD LAYOUT
SCALE 8:1

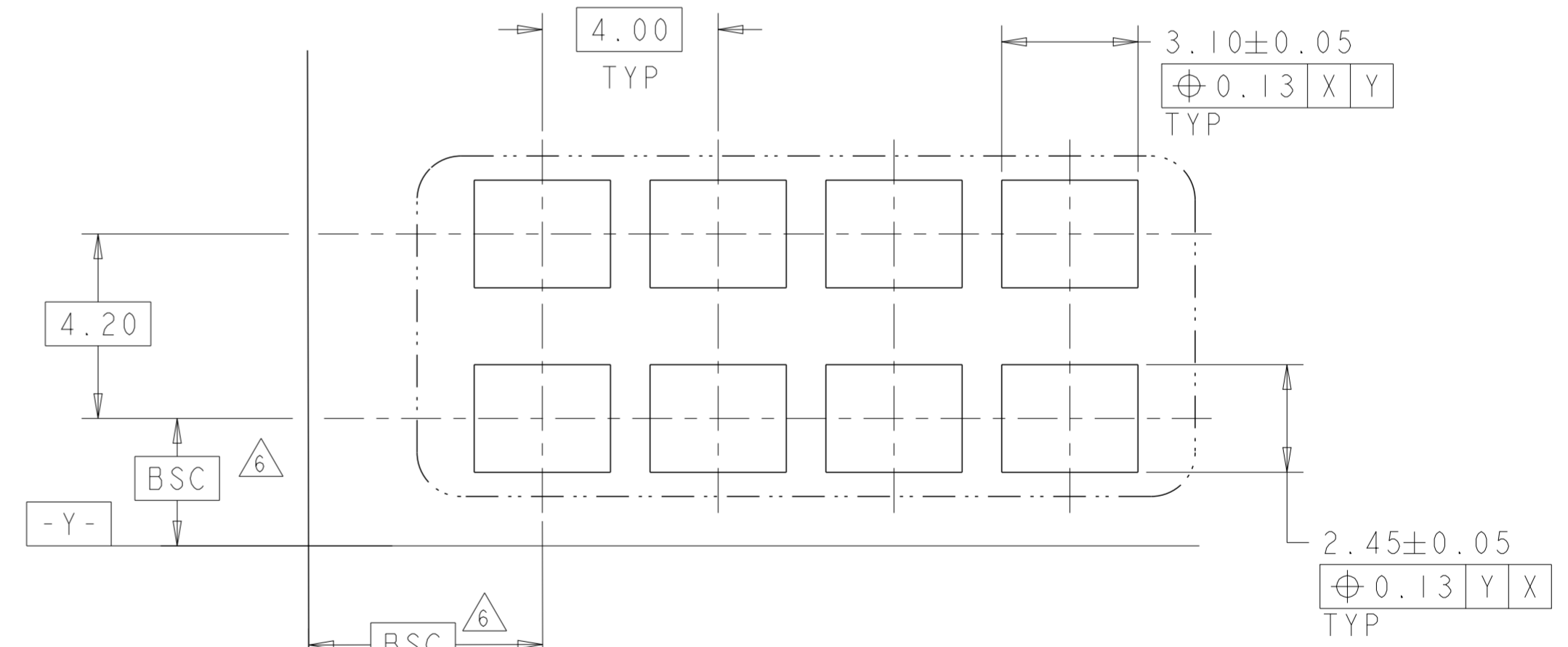

4 POSITION
RECOMMENDED PAD LAYOUT
SCALE 8:1

THIS DRAWING IS A CONTROLLED DOCUMENT.		DWN C DAILY 09DEC2008	STE TE Connectivity		
		CHK J DYER 09DEC2008			
DIMENSIONS:	TOLERANCES UNLESS OTHERWISE SPECIFIED:	APVD	NAME		
mm	0 PLC ±	-	ASSEMBLY,		
	1 PLC ±0.5	PRODUCT SPEC	IDC SSL CONNECTOR,		
	2 PLC ±0.13	108-2404	SMT, CLOSED END		
	3 PLC ±	APPLICATION SPEC	SIZE	CAGE CODE	
	4 PLC ±	114-13266	A2	00779	
MATERIAL	FINISH	WEIGHT	DRAWING NO		
material_2	finish_spec_2	-	C-2106003		
Customer Drawing		SCALE	SHEET	OF	REV
		2:1	1	4	C

THIS DRAWING IS UNPUBLISHED. RELEASED FOR PUBLICATION 20
 © COPYRIGHT 20 BY - ALL RIGHTS RESERVED.

LOC		DIST		REVISIONS				
P	LTR	DESCRIPTION			DATE	DWN	APVD	
-	-	SEE SHEET 1			-	-	-	

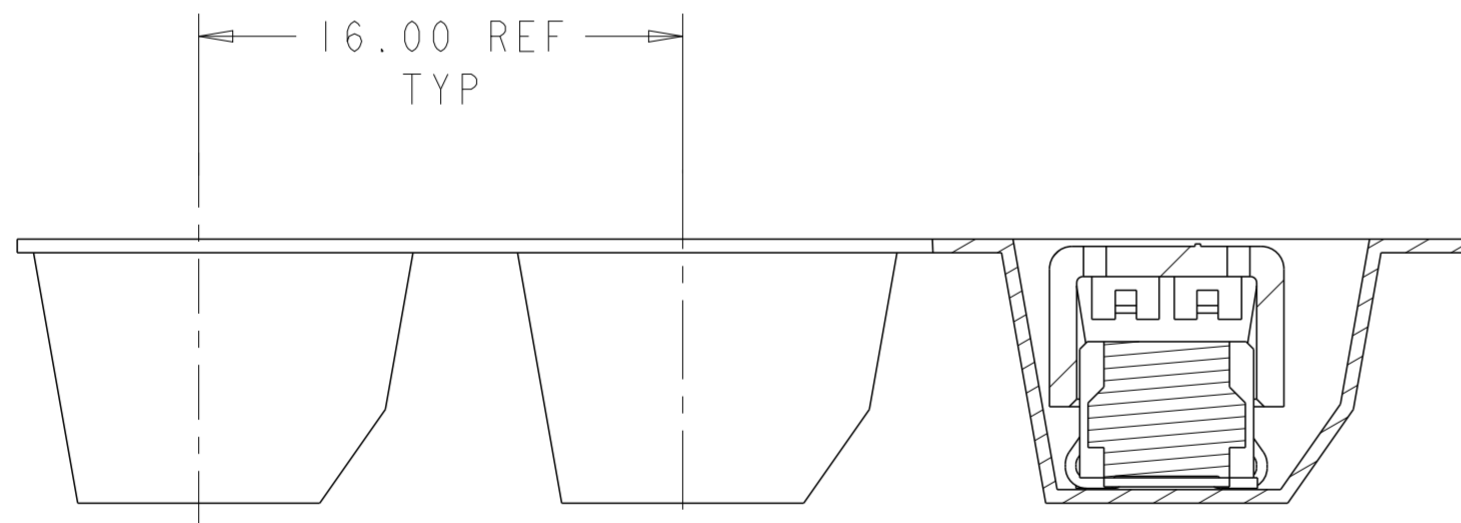
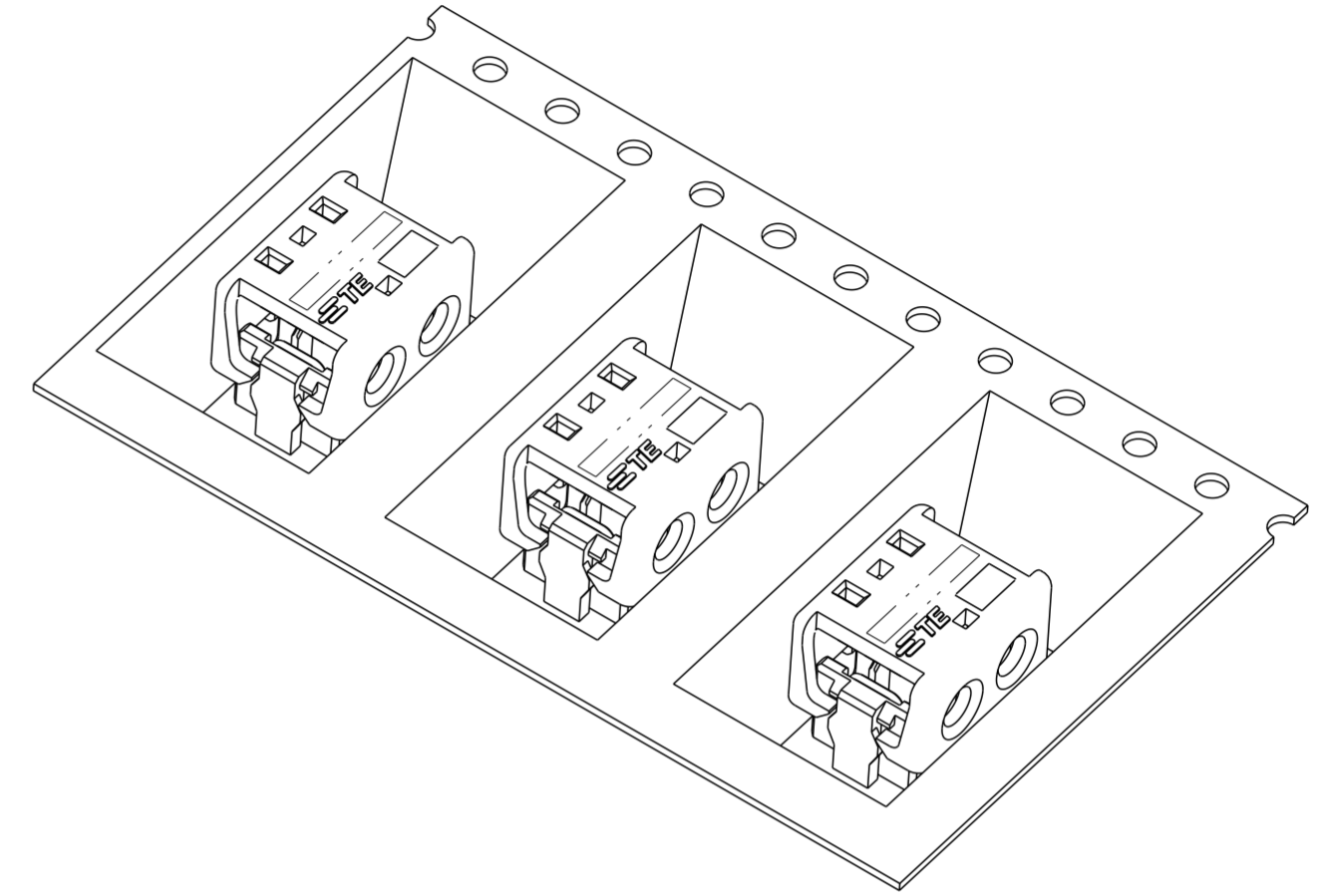
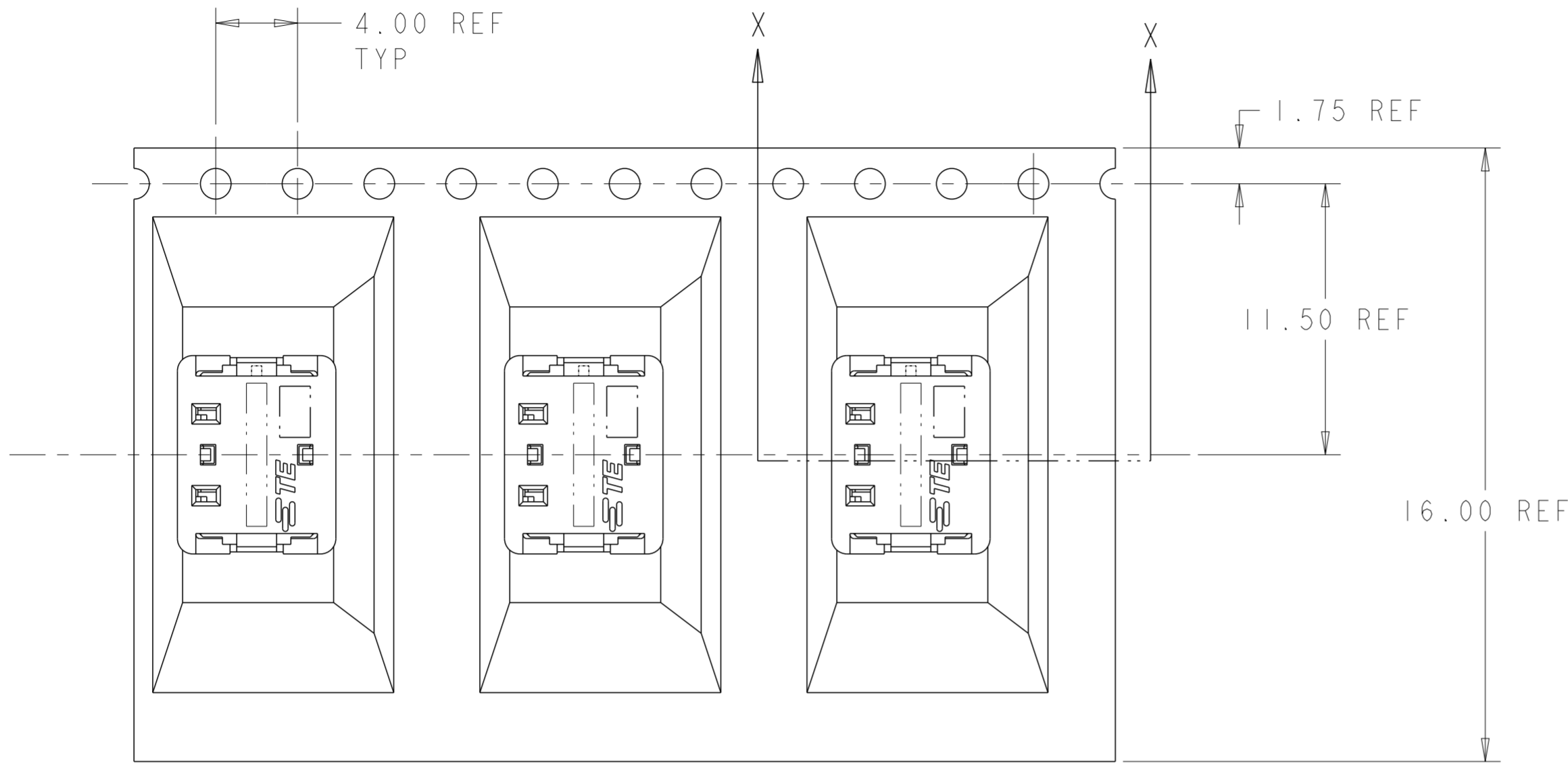

SECTION X-X

2106003-2 SHOWN IN POCKET TAPE

THIS DRAWING IS A CONTROLLED DOCUMENT.		DWN C DAILY 09DEC2008	 TE Connectivity	
		CHK J DYER 09DEC2008		
DIMENSIONS:	TOLERANCES UNLESS OTHERWISE SPECIFIED:	APVD -	NAME ASSEMBLY, IDC SSL CONNECTOR, SMT, CLOSED END	
mm	0 PLC ± 1 PLC ±0.5 2 PLC ±0.13 3 PLC ± 4 PLC ± ANGLES ±	PRODUCT SPEC 108-2404	SIZE 114-13266	RESTRICTED TO -
MATERIAL	FINISH	APPLICATION SPEC 114-13266	WEIGHT -	SCALE 2:1
material_2	finish_spec_2	Customer Drawing	Customer Drawing	SHEET 1 OF 4
		DRAWING NO A200779C-2106003		REV C

Данный компонент на территории Российской Федерации

Вы можете приобрести в компании MosChip.

Для оперативного оформления запроса Вам необходимо перейти по данной ссылке:

<http://moschip.ru/get-element>

Вы можете разместить у нас заказ для любого Вашего проекта, будь то серийное производство или разработка единичного прибора.

В нашем ассортименте представлены ведущие мировые производители активных и пассивных электронных компонентов.

Нашей специализацией является поставка электронной компонентной базы двойного назначения, продукции таких производителей как XILINX, Intel (ex.ALTERA), Vicor, Microchip, Texas Instruments, Analog Devices, Mini-Circuits, Amphenol, Glenair.

Сотрудничество с глобальными дистрибьюторами электронных компонентов, предоставляет возможность заказывать и получать с международных складов практически любой перечень компонентов в оптимальные для Вас сроки.

На всех этапах разработки и производства наши партнеры могут получить квалифицированную поддержку опытных инженеров.

Система менеджмента качества компании отвечает требованиям в соответствии с ГОСТ Р ИСО 9001, ГОСТ РВ 0015-002 и ЭС РД 009

Офис по работе с юридическими лицами:

105318, г.Москва, ул.Щербаковская д.3, офис 1107, 1118, ДЦ «Щербаковский»

Телефон: +7 495 668-12-70 (многоканальный)

Факс: +7 495 668-12-70 (доб.304)

E-mail: info@moschip.ru

Skype отдела продаж:

moschip.ru

moschip.ru_4

moschip.ru_6

moschip.ru_9