



## Main

Range of product	OsiSense XU
Series name	Application packaging
Electronic sensor type	Photo-electric sensor
Product specific application	Colour
Sensor name	XUK
Sensor design	Compact 50 x 50
Detection system	Diffuse
Emission	White LED
[Sn] nominal sensing distance	0.79 in (20 mm) spot Ø 4 mm
Material	Plastic
Supply circuit type	DC
Type of output signal	Discrete
Wiring technique	3-wire
Discrete output type	NPN
Discrete output function	1 NO
Electrical connection	1 male connector M12 adjustable through 90°, 8 pins

## Complementary

Enclosure material	ABS
Lens material	Glass
Type of colour processing	RGB
Output type	Solid state
Output function governance	Light on
Add on input	Synchro + locking
Signalling function	4-digit display
Status LED	1 LED (yellow) output state OUT 3 LEDs (green) output active
[Us] rated supply voltage	12...24 V DC
Supply voltage limits	10...30 V DC
Switching capacity in mA	<= 100 mA (reverse polarity, overload and short-circuit protection)
Switching frequency	<= 1500 Hz
Voltage drop	<= 2 V (closed state)
Current consumption	<= 60 mA (no-load)
Time delay range	10 ms 20 ms 30 ms 40 ms 5 ms
Delay response	0.335 ms
Delay recovery	0.335 ms
Setting-up	Operating mode Sensitivity adjustment with teach mode Tolerance level
Depth	1.97 in (50 mm)
Height	1.97 in (50 mm)
Width	0.98 in (25 mm)
Product weight	0.19 lb(US) (0.085 kg)

## Environment

The information provided in this documentation contains general descriptions and/or technical characteristics of the products contained herein. This documentation is not intended as a substitute for and is not to be used for determining suitability or reliability of these products for specific user applications. It is the duty of any such user or integrator to perform the appropriate and complete risk analysis, evaluation and testing of the products with respect to the relevant specific application or use thereof. Neither Schneider Electric Industries SAS nor any of its affiliates or subsidiaries shall be responsible or liable for misuse of the information contained herein.

product certifications	CE CULus
ambient air temperature for operation	14...131 °F (-10...55 °C)
ambient air temperature for storage	-4...158 °F (-20...70 °C)
vibration resistance	7 gn, amplitude = +/- 0.5 mm (f = 10...55 Hz) on the 3 axes conforming to IEC 60068-2-6
shock resistance	30 gn (duration = 11 ms) (6 shocks on each axis) conforming to IEC 60068-2-27
IP degree of protection	IP65 conforming to IEC 60529

## Offer Sustainability

Not Green Premium product	Not Green Premium product
Compliant - since 0623 - Schneider Electric declaration of conformity	Compliant - since 0623 - Schneider Electric declaration of conformity
Reference not containing SVHC above the threshold	Reference not containing SVHC above the threshold
WARNING: This product can expose you to chemicals including:	WARNING: This product can expose you to chemicals including:
Diisononyl phthalate (DINP), which is known to the State of California to cause cancer, and	Diisononyl phthalate (DINP), which is known to the State of California to cause cancer, and
Di-isodecyl phthalate (DIDP), which is known to the State of California to cause birth defects or other reproductive harm.	Di-isodecyl phthalate (DIDP), which is known to the State of California to cause birth defects or other reproductive harm.
For more information go to <a href="http://www.p65warnings.ca.gov">www.p65warnings.ca.gov</a>	For more information go to <a href="http://www.p65warnings.ca.gov">www.p65warnings.ca.gov</a>

## Contractual warranty

Warranty period	18 months
-----------------	-----------

## Dimensions

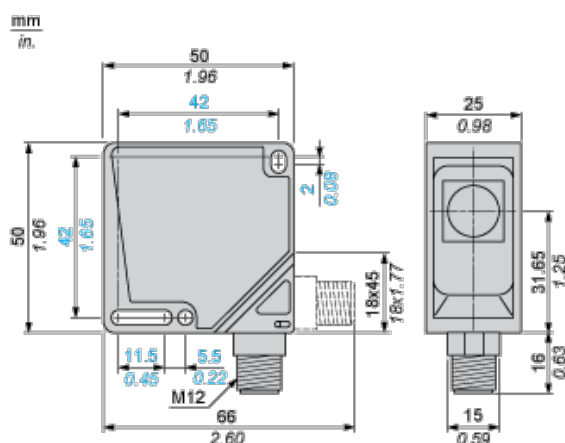

## Wiring Schemes

### Sensor Connector Pin View

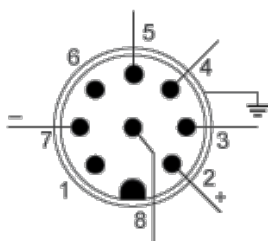

Pin N°	Type	Colour (2)
1	-	WH (white)
2	10...30 VDC	BN (brown)
3	Output 1	TAN (tan)

4	Output 2	YE (yellow)
5	Output 3	GY (grey)
6	-	PK (pink)
7	0 V	VT (violet)
8	Synchro	RD (red)
-	Screening	TR (transparent)

### NPN Output + Synchro Input

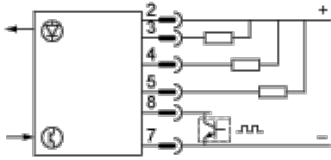

## Curves

### Detection Curve

Detection distance related to object's degree of reflection

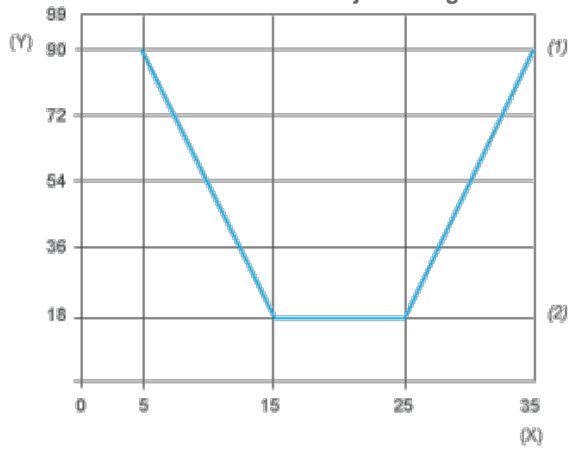

- (y) Object reflection
- (x) Detection distance (mm)
- (1) White Yellow light
- (2) Dark blue Black

### Detection Zone and Spot Size

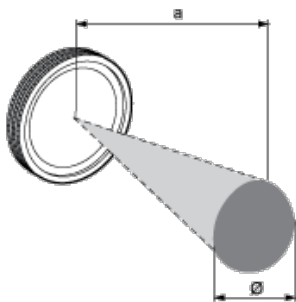

a (mm)	Ø (mm)
20	4

## Данный компонент на территории Российской Федерации

### Вы можете приобрести в компании MosChip.

Для оперативного оформления запроса Вам необходимо перейти по данной ссылке:

<http://moschip.ru/get-element>

Вы можете разместить у нас заказ для любого Вашего проекта, будь то серийное производство или разработка единичного прибора.

В нашем ассортименте представлены ведущие мировые производители активных и пассивных электронных компонентов.

Нашей специализацией является поставка электронной компонентной базы двойного назначения, продукции таких производителей как XILINX, Intel (ex.ALTERA), Vicor, Microchip, Texas Instruments, Analog Devices, Mini-Circuits, Amphenol, Glenair.

Сотрудничество с глобальными дистрибьюторами электронных компонентов, предоставляет возможность заказывать и получать с международных складов практически любой перечень компонентов в оптимальные для Вас сроки.

На всех этапах разработки и производства наши партнеры могут получить квалифицированную поддержку опытных инженеров.

Система менеджмента качества компании отвечает требованиям в соответствии с ГОСТ Р ИСО 9001, ГОСТ РВ 0015-002 и ЭС РД 009

### Офис по работе с юридическими лицами:

105318, г.Москва, ул.Щербаковская д.3, офис 1107, 1118, ДЦ «Щербаковский»

Телефон: +7 495 668-12-70 (многоканальный)

Факс: +7 495 668-12-70 (доб.304)

E-mail: [info@moschip.ru](mailto:info@moschip.ru)

Skype отдела продаж:

moschip.ru

moschip.ru\_4

moschip.ru\_6

moschip.ru\_9