

FP-BGA  
Commercial Temp  
Industrial Temp

**128K x 8**  
**1Mb Asynchronous SRAM**

7, 8, 10, 12 ns  
3.3 V  $V_{DD}$   
Center  $V_{DD}$  and  $V_{SS}$

**Features**

- Fast access time: 7, 8, 10, 12 ns
- CMOS low power operation: 140/120/95/80 mA at minimum cycle time
- Single 3.3 V power supply
- All inputs and outputs are TTL-compatible
- Fully static operation
- Industrial Temperature Option:  $-40^{\circ}$  to  $85^{\circ}\text{C}$
- Package line up
  - U: 6 mm x 8 mm Fine Pitch Ball Grid Array package
  - GU: RoHS-compliant 6 mm x 8 mm Fine Pitch Ball Grid Array package

**Description**

The GS71108A is a high speed CMOS Static RAM organized as 131,072 words by 8 bits. Static design eliminates the need for external clocks or timing strobes. The GS 71108 operates on a single 3.3 V power supply and all inputs and outputs are TTL-compatible. The GS71108A is available in the 6 mm x 8 mm Fine Pitch BGA package.

**Fine Pitch BGA 128K x 8-Bump Configuration**

	1	2	3	4	5	6
A	NC	$\overline{\text{OE}}$	A2	A6	A7	NC
B	DQ1	NC	A1	A5	$\overline{\text{CE}}$	DQ8
C	DQ2	NC	A0	A4	NC	DQ7
D	$V_{SS}$	NC	NC	A3	NC	$V_{DD}$
E	$V_{DD}$	NC	NC	NC	NC	$V_{SS}$
F	DQ3	NC	A14	A11	DQ5	DQ6
G	DQ4	NC	A15	A12	$\overline{\text{WE}}$	A8
H	NC	A10	A16	A13	A9	NC

Package U  
6 mm x 8 mm, 0.75 mm Bump Pitch  
Top View

**Pin Descriptions**

Symbol	Description
A <sub>0</sub> –A <sub>16</sub>	Address input
DQ <sub>1</sub> –DQ <sub>8</sub>	Data input/output
$\overline{\text{CE}}$	Chip enable input
$\overline{\text{WE}}$	Write enable input
$\overline{\text{OE}}$	Output enable input
$V_{DD}$	+3.3 V power supply
$V_{SS}$	Ground
NC	No connect

Block Diagram

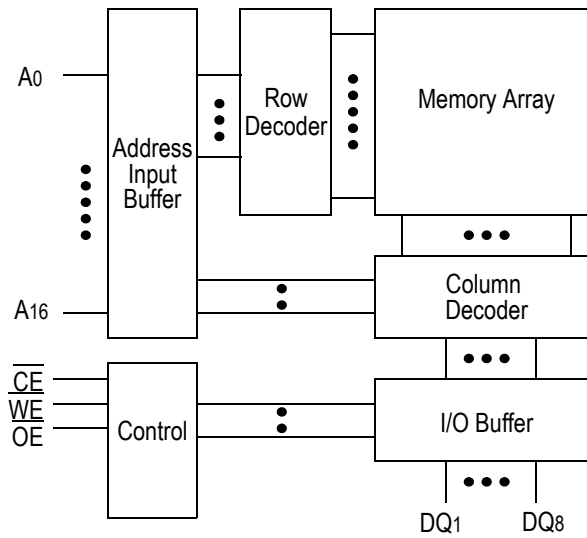

Truth Table

$\overline{CE}$	$\overline{OE}$	$\overline{WE}$	DQ1 to DQ8	$V_{DD}$ Current
H	X	X	Not Selected	ISB1, ISB2
L	L	H	Read	IDD
L	X	L	Write	
L	H	H	High Z	

**Note:**  
X: "H" or "L"

**Absolute Maximum Ratings**

Parameter	Symbol	Rating	Unit
Supply Voltage	V <sub>DD</sub>	-0.5 to +4.6	V
Input Voltage	V <sub>IN</sub>	-0.5 to V <sub>DD</sub> +0.5 (≤ 4.6 V max.)	V
Output Voltage	V <sub>OUT</sub>	-0.5 to V <sub>DD</sub> +0.5 (≤ 4.6 V max.)	V
Allowable power dissipation	PD	0.7	W
Storage temperature	T <sub>STG</sub>	-55 to 150	°C

**Note:**

Permanent device damage may occur if Absolute Maximum Ratings are exceeded. Functional operation shall be restricted to Recommended Operating Conditions. Exposure to higher than recommended voltages for extended periods of time could affect device reliability.

**Recommended Operating Conditions**

Parameter	Symbol	Min	Typ	Max	Unit
Supply Voltage for -7/-8/-10/-12	V <sub>DD</sub>	3.0	3.3	3.6	V
Input High Voltage	V <sub>IH</sub>	2.0	—	V <sub>DD</sub> +0.3	V
Input Low Voltage	V <sub>IL</sub>	-0.3	—	0.8	V
Ambient Temperature, Commercial Range	T <sub>Ac</sub>	0	—	70	°C
Ambient Temperature, Industrial Range	T <sub>AI</sub>	-40	—	85	°C

**Notes:**

1. Input overshoot voltage should be less than V<sub>DD</sub> +2 V and not exceed 20 ns.
2. Input undershoot voltage should be greater than -2 V and not exceed 20 ns.

**Capacitance**

Parameter	Symbol	Test Condition	Max	Unit
Input Capacitance	C <sub>IN</sub>	V <sub>IN</sub> = 0 V	5	pF
Output Capacitance	C <sub>OUT</sub>	V <sub>OUT</sub> = 0 V	7	pF

**Notes:**

1. Tested at T<sub>A</sub> = 25°C, f = 1 MHz
2. These parameters are sampled and are not 100% tested.

**DC I/O Pin Characteristics**

Parameter	Symbol	Test Conditions	Min	Max
Input Leakage Current	I <sub>IL</sub>	V <sub>IN</sub> = 0 to V <sub>DD</sub>	-1 uA	1 uA
Output Leakage Current	I <sub>LO</sub>	Output High Z V <sub>OUT</sub> = 0 to V <sub>DD</sub>	-1 uA	1 uA
Output High Voltage	V <sub>OH</sub>	I <sub>OH</sub> = -4 mA	2.4	—
Output Low Voltage	V <sub>OL</sub>	I <sub>LO</sub> = +4 mA	—	0.4 V

**Power Supply Currents**

Parameter	Symbol	Test Conditions	0 to 70°C				-40 to 85°C			
			7 ns	8 ns	10 ns	12 ns	7 ns	8 ns	10 ns	12 ns
Operating Supply Current	I <sub>DD</sub>	$\overline{CE} \leq V_{IL}$ All other inputs $\geq V_{IH}$ or $\leq V_{IL}$ Min. cycle time I <sub>OUT</sub> = 0 mA	140 mA	120 mA	95 mA	80 mA	145 mA	125 mA	100 mA	85 mA
Standby Current	I <sub>SB1</sub>	$\overline{CE} \geq V_{IH}$ All other inputs $\geq V_{IH}$ or $\leq V_{IL}$ Min. cycle time	25 mA	20 mA	20 mA	15 mA	30 mA	25 mA	25 mA	20 mA
Standby Current	I <sub>SB2</sub>	$\overline{CE} \geq V_{DD} - 0.2 V$ All other inputs $\geq V_{DD} - 0.2 V$ or $\leq 0.2 V$	2 mA				5 mA			

## AC Test Conditions

Parameter	Conditions
Input high level	$V_{IH} = 2.4\text{ V}$
Input low level	$V_{IL} = 0.4\text{ V}$
Input rise time	$t_r = 1\text{ V/ns}$
Input fall time	$t_f = 1\text{ V/ns}$
Input reference level	1.4 V
Output reference level	1.4 V
Output load	<b>Fig. 1 &amp; 2</b>

### Notes:

1. Include scope and jig capacitance.
2. Test conditions as specified with output loading as shown in **Fig. 1** unless otherwise noted.
3. Output load 2 for  $t_{LZ}$ ,  $t_{HZ}$ ,  $t_{OLZ}$  and  $t_{OHZ}$

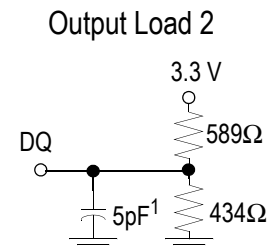
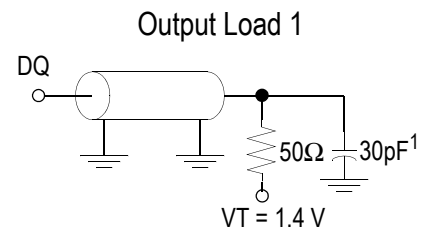

## AC Characteristics

### Read Cycle

Parameter	Symbol	-7		-8		-10		-12		Unit
		Min	Max	Min	Max	Min	Max	Min	Max	
Read cycle time	$t_{RC}$	7	—	8	—	10	—	12	—	ns
Address access time	$t_{AA}$	—	7	—	8	—	10	—	12	ns
Chip enable access time ( $\overline{CE}$ )	$t_{AC}$	—	7	—	8	—	10	—	12	ns
Output enable to output valid ( $\overline{OE}$ )	$t_{OE}$	—	3	—	3.5	—	4	—	5	ns
Output hold from address change	$t_{OH}$	3	—	3	—	3	—	3	—	ns
Chip enable to output in low Z ( $\overline{CE}$ )	$t_{LZ}^*$	3	—	3	—	3	—	3	—	ns
Output enable to output in low Z ( $\overline{OE}$ )	$t_{OLZ}^*$	0	—	0	—	0	—	0	—	ns
Chip disable to output in High Z ( $\overline{CE}$ )	$t_{HZ}^*$	—	3.5	—	4	—	5	—	6	ns
Output disable to output in High Z ( $\overline{OE}$ )	$t_{OHZ}^*$	—	3	—	3.5	—	4	—	5	ns

\* These parameters are sampled and are not 100% tested

Read Cycle 1:  $\overline{CE} = \overline{OE} = V_{IL}, \overline{WE} = V_{IH}$

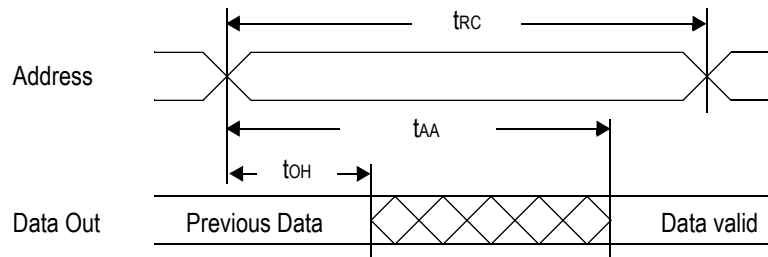

Read Cycle 2:  $\overline{WE} = V_{IH}$

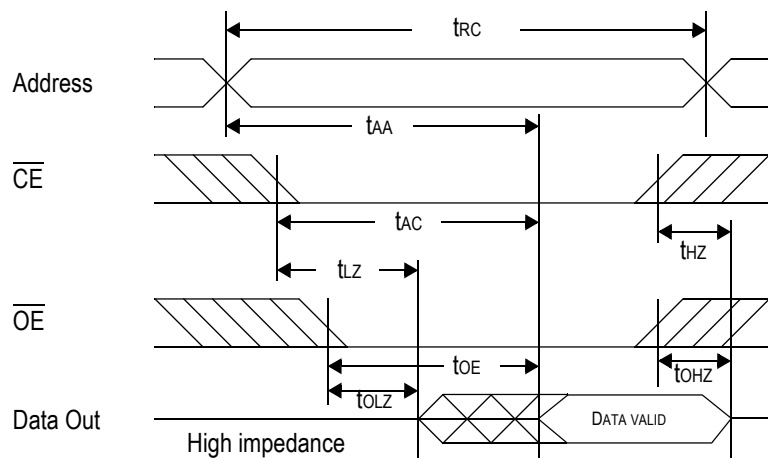

**Write Cycle**

Parameter	Symbol	-7		-8		-10		-12		Unit
		Min	Max	Min	Max	Min	Max	Min	Max	
Write cycle time	tWC	7	—	8	—	10	—	12	—	ns
Address valid to end of write	tAW	5	—	5.5	—	7	—	8	—	ns
Chip enable to end of write	tCW	5	—	5.5	—	7	—	8	—	ns
Data set up time	tDW	3	—	4	—	5	—	6	—	ns
Data hold time	tDH	0	—	0	—	0	—	0	—	ns
Write pulse width	tWP	5	—	5.5	—	7	—	8	—	ns
Address set up time	tAS	0	—	0	—	0	—	0	—	ns
Write recovery time ( $\overline{WE}$ )	tWR	0	—	0	—	0	—	0	—	ns
Write recovery time ( $\overline{CE}$ )	tWR1	0	—	0	—	0	—	0	—	ns
Output Low Z from end of write	tWLZ*	3	—	3	—	3	—	3	—	ns
Write to output in High Z	tWHZ*	—	3	—	3.5	—	4	—	5	ns

\* These parameters are sampled and are not 100% tested

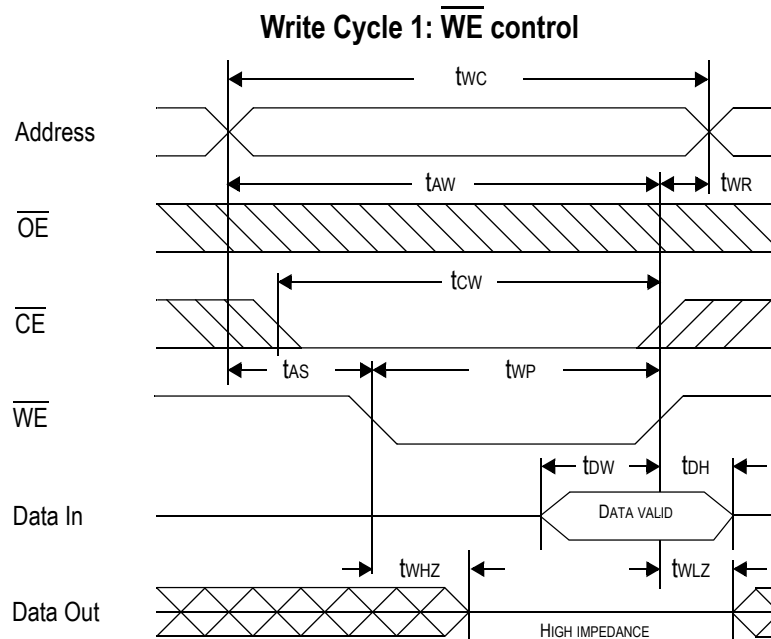

Write Cycle 2:  $\overline{CE}$  control

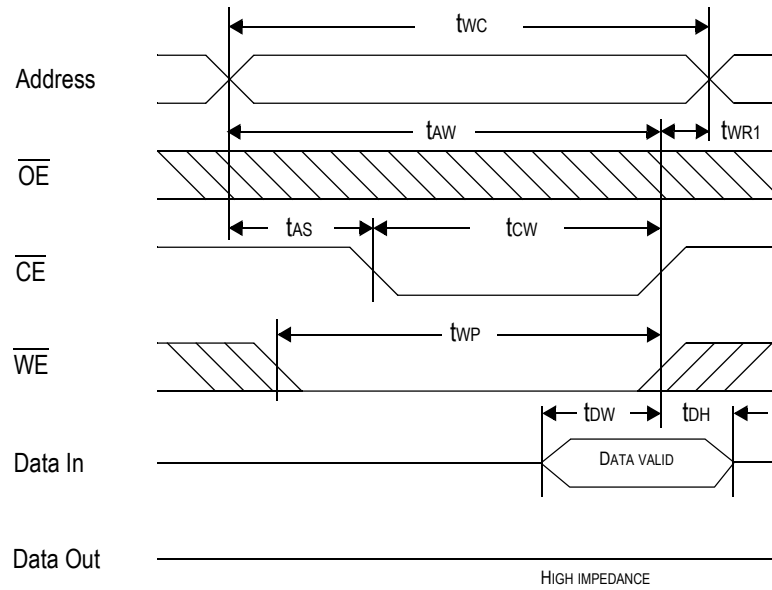



6 mm x 8 mm Fine Pitch BGA

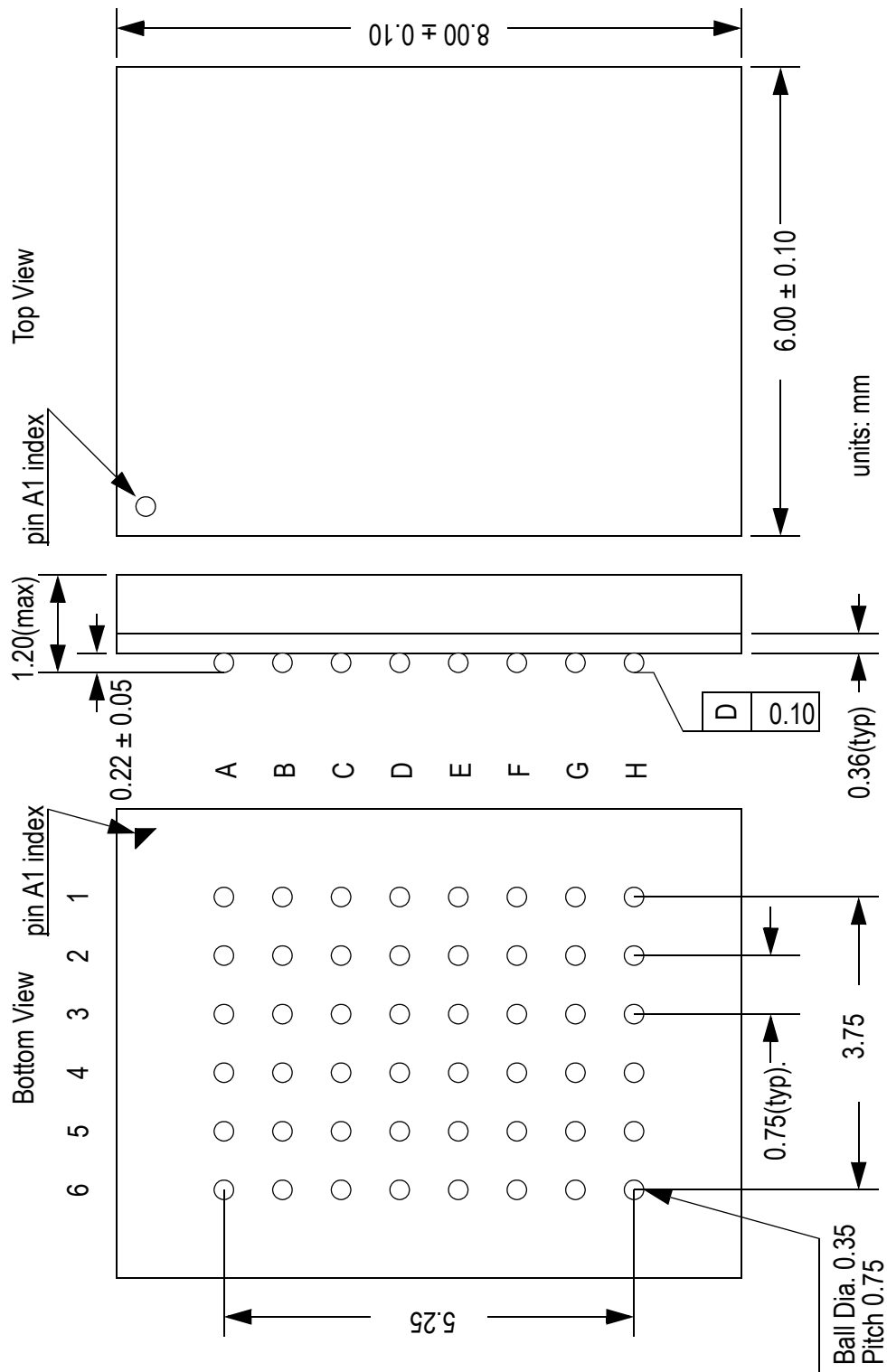

**Ordering Information**

Part Number*	Package	Access Time	Temp. Range
GS71108AU-7	6 mm x 8 mm Fine Pitch BGA	7 ns	Commercial
GS71108AU-8	6 mm x 8 mm Fine Pitch BGA	8 ns	Commercial
GS71108AU-10	6 mm x 8 mm Fine Pitch BGA	10 ns	Commercial
GS71108AU-12	6 mm x 8 mm Fine Pitch BGA	12 ns	Commercial
GS71108AU-7I	6 mm x 8 mm Fine Pitch BGA	7 ns	Industrial
GS71108AU-8I	6 mm x 8 mm Fine Pitch BGA	8 ns	Industrial
GS71108AU-10I	6 mm x 8 mm Fine Pitch BGA	10 ns	Industrial
GS71108AU-12I	6 mm x 8 mm Fine Pitch BGA	12 ns	Industrial
GS71108AGU-7	RoHS-compliant 6 mm x 8 mm Fine Pitch BGA	7 ns	Commercial
GS71108AGU-8	RoHS-compliant 6 mm x 8 mm Fine Pitch BGA	8 ns	Commercial
GS71108AGU-10	RoHS-compliant 6 mm x 8 mm Fine Pitch BGA	10 ns	Commercial
GS71108AGU-12	RoHS-compliant 6 mm x 8 mm Fine Pitch BGA	12 ns	Commercial
GS71108AGU-7I	RoHS-compliant 6 mm x 8 mm Fine Pitch BGA	7 ns	Industrial
GS71108AGU-8I	RoHS-compliant 6 mm x 8 mm Fine Pitch BGA	8 ns	Industrial
GS71108AGU-10I	RoHS-compliant 6 mm x 8 mm Fine Pitch BGA	10 ns	Industrial
GS71108AGU-12I	RoHS-compliant 6 mm x 8 mm Fine Pitch BGA	12 ns	Industrial

**Note:**

Customers requiring delivery in Tape and Reel should add the character "T" to the end of the part number. For example: GS71108AU-8T.

**1Mb Asynchronous Datasheet Revision History**

<b>Rev. Code: Old; New</b>	<b>Types of Changes Format or Content</b>	<b>Page #/Revisions/Reason</b>
71108A_r1		• Creation of new datasheet
71108A_r1; 71108A_r1_01	Content	• Added 6 ns speed bin to entire document
71108A_r1_01; 71108A_r1_02	Content	• Updated all power numbers • Changed 6 mm x 10 mm package designator from U to X
71108A_r1_02; 71108A_r1_03	Content	• Updated Recommended Operating Conditions table on page 3 • Updated Power Supply Currents table • Changed FPBGA package from 6 x 10 to 6 x 8 (package U)
71108A_r1_03; 71108A_r1_04	Content	• Removed 6 ns speed bin from entire document • Added 7 ns speed bin to entire document
71108A_r1_04; 71108A_r1_05	Content	• Added missing 300 mil SOJ mechanical drawing
71108A_r1_05; 71108A_r1_06	Content	• Updated format • Added RoHS-compliant information for TSOP-II package
71108A_r1_06; 71108A_r1_07	Content	• Added RoHS-compliant information for FP-BGA package
71108A_r1_07; 71108A_r1_08	Content	• Added RoHS-compliant 400 mil, 32-pin SOJ
71108A_r1_08; 71108A_r1_09	Content	• Updated to MP in ordering information table
71108A_r1_09; 71108A_r1_10	Content	• Removed Status column from Ordering Information Table • Removed SOJ package reference from entire document • (Rev1.10a: Removed TSOP-II references due to EOL (EOL_091016111-CY)

## Данный компонент на территории Российской Федерации

### Вы можете приобрести в компании MosChip.

Для оперативного оформления запроса Вам необходимо перейти по данной ссылке:

<http://moschip.ru/get-element>

Вы можете разместить у нас заказ для любого Вашего проекта, будь то серийное производство или разработка единичного прибора.

В нашем ассортименте представлены ведущие мировые производители активных и пассивных электронных компонентов.

Нашей специализацией является поставка электронной компонентной базы двойного назначения, продукции таких производителей как XILINX, Intel (ex.ALTERA), Vicor, Microchip, Texas Instruments, Analog Devices, Mini-Circuits, Amphenol, Glenair.

Сотрудничество с глобальными дистрибьюторами электронных компонентов, предоставляет возможность заказывать и получать с международных складов практически любой перечень компонентов в оптимальные для Вас сроки.

На всех этапах разработки и производства наши партнеры могут получить квалифицированную поддержку опытных инженеров.

Система менеджмента качества компании отвечает требованиям в соответствии с ГОСТ Р ИСО 9001, ГОСТ РВ 0015-002 и ЭС РД 009

### Офис по работе с юридическими лицами:

105318, г.Москва, ул.Щербаковская д.3, офис 1107, 1118, ДЦ «Щербаковский»

Телефон: +7 495 668-12-70 (многоканальный)

Факс: +7 495 668-12-70 (доб.304)

E-mail: [info@moschip.ru](mailto:info@moschip.ru)

Skype отдела продаж:

moschip.ru

moschip.ru\_4

moschip.ru\_6

moschip.ru\_9