

HMIC™ Silicon SP6T PIN Diode Switch with Integrated Bias Network

Rev. V3

Features

- Broad Bandwidth Specified up to 18 GHz
- Integrated Bias Network
- Low Insertion Loss / High Isolation
- Rugged, Glass Encapsulated Construction
- Fully Monolithic
- RoHS* Compliant

Description

The MASW-006102-13610 device is a SP6T broadband switch with integrated bias network utilizing MACOM's HMIC™ (Heterolithic Microwave Integrated Circuit) process, US Patent 5,268,310. This process allows the incorporation of silicon pedestals that form series and shunt diodes or vias by imbedding them in low loss, low dispersion glass. By using small spacing between elements, this combination of silicon and glass gives HMIC devices low loss and high isolation performance with exceptional repeatability through low millimeter frequencies. Large bond pads facilitate the use of low inductance ribbon bonds, while gold backside metallization allows for manual or automatic chip bonding via 80/20 - Au/Sn, 62/36/2 - Sn/Pb/Ag solders or electrically conductive silver epoxy.

These high performance switches are suitable for use in multi-band ECM, Radar, and instrumentation control circuits where high isolation to insertion loss ratios are required. With a standard +5 V / -5 V, TTL controlled PIN diode driver, 80 ns switching speeds can be achieved.

Ordering Information

Part Number	Package
MASW-006102-13610	Waffle Pack

Functional Diagrams

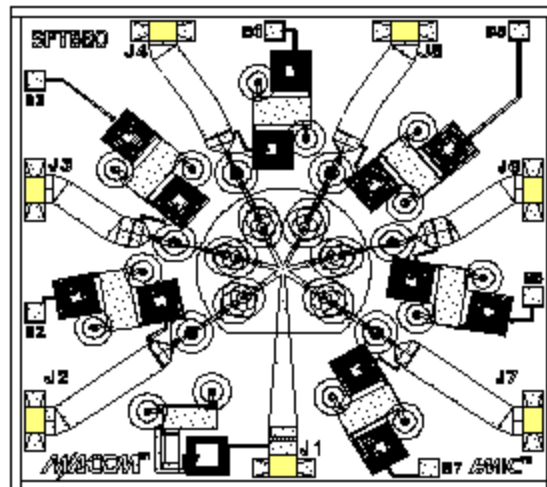

Yellow areas denote wire bond pads

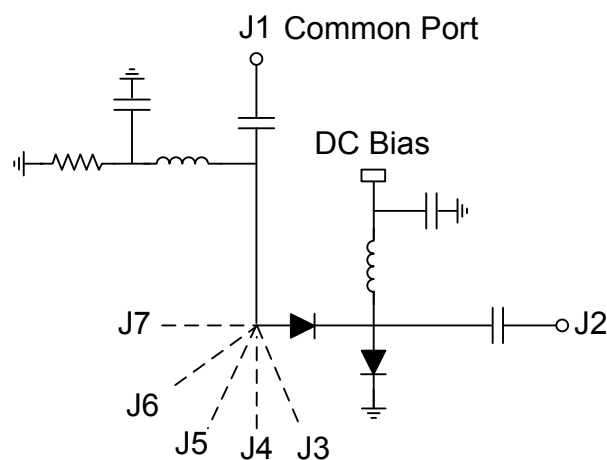

*Restrictions on Hazardous Substances, European Union Directive 2011/65/EU.

Electrical Specifications: $T_A = +25^\circ\text{C}$, 10 mA (On-Wafer Measurements)

Parameter	Test Conditions	Units	Min.	Typ.	Max.
Insertion Loss	6 GHz	dB	—	1.0	1.4
	12 GHz			1.3	2.0
	18 GHz			1.9	2.9
Isolation	6 GHz	dB	43	49	—
	12 GHz		35	43	
	18 GHz		30	39	
Input Return Loss	6 GHz	dB	—	18	—
	12 GHz			20	
	18 GHz			16	
Isolation	6 GHz	dB	—	19	—
	12 GHz			22	
	18 GHz			20	
Switching Speed ¹	10 GHz	ns	—	80	—

1. Typical switching speed is measured from (10% to 90% and 90% to 10% of detected RF voltage), driven by TTL compatible drivers. In the modulating state, (the switching port is modulating, all other ports are in steady state isolation.) The switching speed is measured using an RC network using the following values: $R = 50 - 200 \Omega$, $C = 390 - 1000 \text{ pF}$. Driver spike current, $I_C = C \text{ dv/dt}$, ratio of spike current to steady state current, is typically 10:1.

Absolute Maximum Ratings^{2,3,4}

Parameter	Absolute Maximum
RF CW Incident Power	+33 dBm
Reverse Voltage	-50 V
Bias Current per Port	±50 mA @ +25°C
Junction Temperature	+175°C
Operating Temperature	-65°C to +125°C
Storage Temperature	-65°C to +150°C

- Exceeding any one or combination of these limits may cause permanent damage to this device.
- MACOM does not recommend sustained operation near these survivability limits.
- Maximum operating conditions for a combination of RF power, DC bias and temperature: +33 dBm CW @ 15 mA (per diode) @ +85°C.

Handling Procedures

Please observe the following precautions to avoid damage:

Static Sensitivity

These electronic devices are sensitive to electrostatic discharge (ESD) and can be damaged by static electricity. Proper ESD control techniques should be used when handling these Class 0 (HBM) and Class C1 (CDM) devices.

Typical Performance Curves:

Insertion Loss vs. Frequency

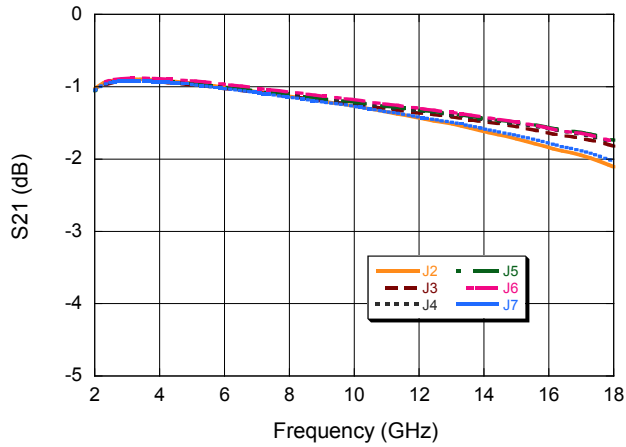

Isolation vs. Frequency

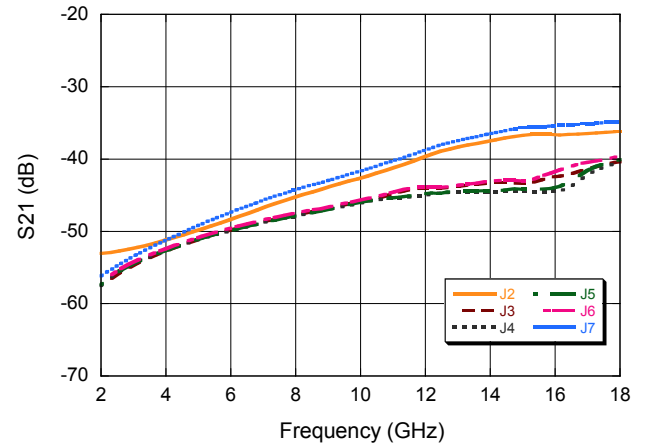

Input Return Loss vs. Frequency (Transmission)

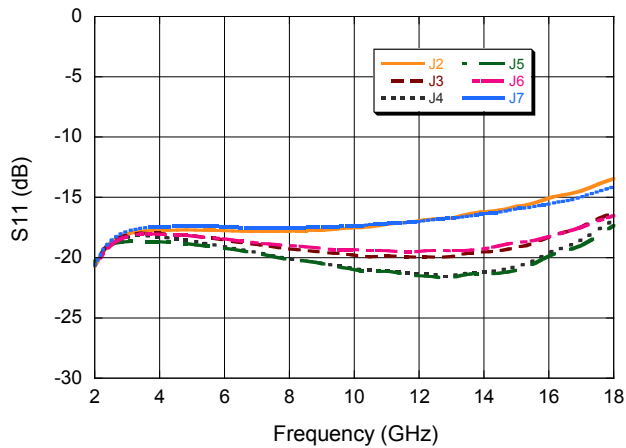

Output Return Loss vs. Frequency (Termination)

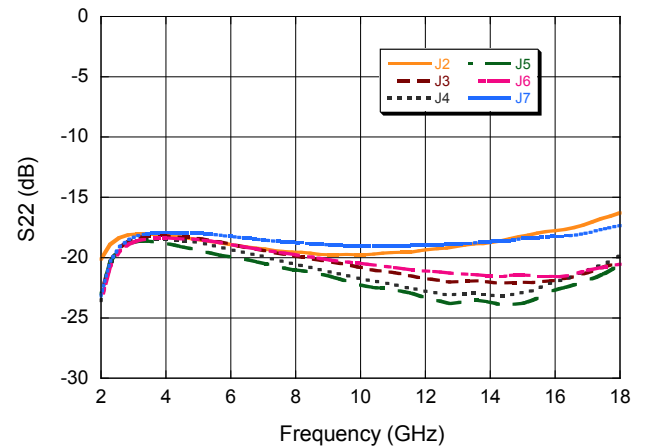

Operation of the MASW-006102-13610 PIN Switch

The simultaneous application of negative DC current to the low loss port and positive DC current to the remaining isolated ports as shown in the schematic provides successful RF operation of the MA4SW Series of PIN Diode Switches. The backside area of the die is the RF and DC return ground plane. The DC bias return is located on common port J1. Constant current sources should supply the DC control currents.

In the low loss state, the series diode must be forward biased and the shunt diode reverse biased. For all isolated ports, the shunt diode is forward biased while the series diode is reverse biased.

This design improves insertion loss, P1dB, IP3, and switching speed by incorporating a voltage pull-up resistor (~100 Ω) in the DC return path (J1) under insertion loss bias. A typical value of |-3 V| is achieved at the insertion loss bias node using ±20 mA, with a Standard, ±5 V TTL controlled PIN diode driver.

Typical Bias Network

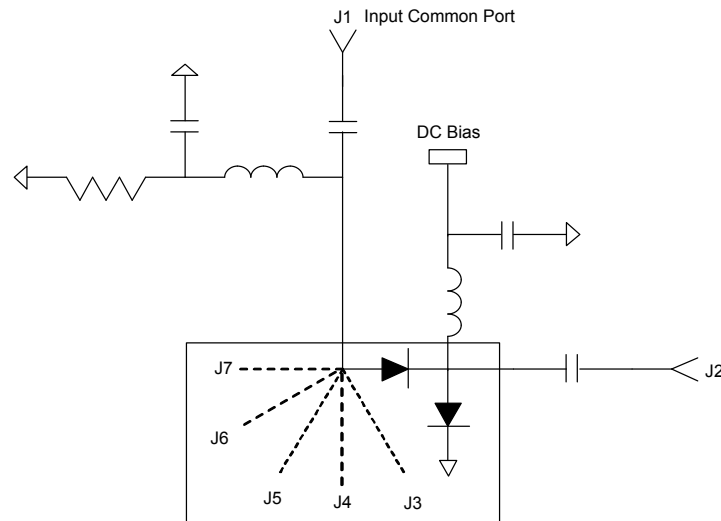

Typical Driver Connections

DC Control Current (mA)						RF Output States					
B2	B3	B4	B5	B6	B7	J1-J2	J1-J3	J1-J4	J1-J5	J1-J6	J1-J7
-10	+10	+10	+10	+10	+10	low loss	Isolation	Isolation	Isolation	Isolation	Isolation
+10	-10	+10	+10	+10	+10	Isolation	low loss	Isolation	Isolation	Isolation	Isolation
+10	+10	-10	+10	+10	+10	Isolation	Isolation	low loss	Isolation	Isolation	Isolation
+10	+10	+10	-10	+10	+10	Isolation	Isolation	Isolation	low loss	Isolation	Isolation
+10	+10	+10	+10	-10	+10	Isolation	Isolation	Isolation	Isolation	low loss	Isolation
+10	+10	+10	+10	+10	-10	Isolation	Isolation	Isolation	Isolation	Isolation	low loss

Chip Dimensions^{5,6}

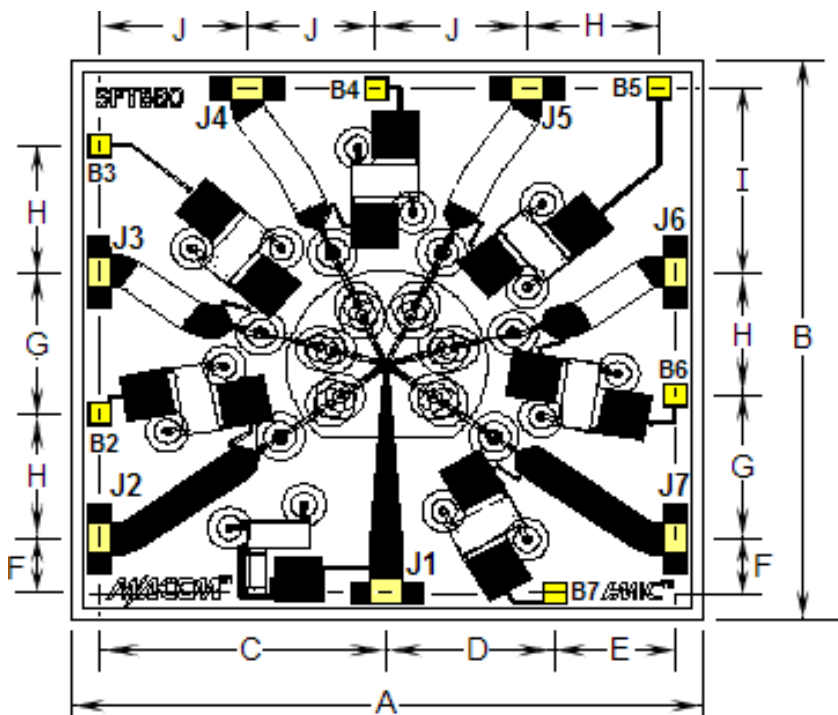

5. Topside and backside metallization is gold, 2.5 μm thick typical.

6. Yellow areas indicate wire bonding pads.

DIM	INCHES		MILLIMETERS	
	MIN	MAX	MIN	MAX
A	0.1325	0.1335	3.3655	3.3909
B	0.1225	0.1235	3.1115	3.1369
C	0.0595	0.0605	1.5113	1.5367
D	0.0345	0.0355	0.8763	0.9017
E	0.0245	0.0255	0.6223	0.6477
F	0.0115	0.0125	0.2921	0.3175
G	0.0305	0.0315	0.7747	0.8001
H	0.0275	0.0285	0.6985	0.7239
I	0.0395	0.0405	1.0033	1.0287
J	0.0295	0.0305	0.7493	0.7747
RF Bond Pads (J1-J7)	0.016 X 0.005 REF.		0.4064 X 0.127 REF.	
DC Bond Pads (B2-B5)	0.005 X 0.005 REF.		0.127 X 0.127 REF.	
Thickness	0.005 REF.		0.127 REF.	

Cleanliness

The chips should be handled in a clean environment free of dust and organic contamination.

Wire / Ribbon Bonding

Thermo compression wedge bonding using 0.003" x 0.00025" ribbon or 0.001" diameter gold wire is recommended. A work stage temperature of 150°C - 200°C, tool tip temperature of 120°C - 150° and a downward force of 18 to 22 grams should be used. If ultrasonic energy is necessary, it should be adjusted to the minimum level required to achieve a good bond. Excessive power or force will fracture the silicon beneath the bond pad causing it to lift. RF bond wires and ribbons should be kept as short as possible for optimum RF performance.

Chip Mounting

HMIC switches have Ti-Pt-Au backside metallization and can be mounted using a gold-tin eutectic solder or conductive epoxy. Mounting surface must be free of contamination and flat.

Eutectic Die Attachment

An 80/20, gold-tin, eutectic solder is recommended. Adjust the work surface temperature to 255°C and the tool tip temperature to 265°C. After placing the chip onto the circuit board re-flow the solder by applying hot forming gas (95/5 Ni/H) to the top surface of the chip. Temperature should be approximately 290°C and not exceed 320°C for more than 20 seconds. Typically no more than three seconds is necessary for attachment. Solders rich in tin should be avoided

Epoxy Die Attachment

A minimum amount of epoxy, 1 - 2 mils thick, should be used to attach chip. A thin epoxy fillet should be visible around the outer perimeter of the chip after placement. Epoxy cure time is typically 1 hour at 150°C.

Данный компонент на территории Российской Федерации

Вы можете приобрести в компании MosChip.

Для оперативного оформления запроса Вам необходимо перейти по данной ссылке:

<http://moschip.ru/get-element>

Вы можете разместить у нас заказ для любого Вашего проекта, будь то серийное производство или разработка единичного прибора.

В нашем ассортименте представлены ведущие мировые производители активных и пассивных электронных компонентов.

Нашей специализацией является поставка электронной компонентной базы двойного назначения, продукции таких производителей как XILINX, Intel (ex.ALTERA), Vicor, Microchip, Texas Instruments, Analog Devices, Mini-Circuits, Amphenol, Glenair.

Сотрудничество с глобальными дистрибьюторами электронных компонентов, предоставляет возможность заказывать и получать с международных складов практически любой перечень компонентов в оптимальные для Вас сроки.

На всех этапах разработки и производства наши партнеры могут получить квалифицированную поддержку опытных инженеров.

Система менеджмента качества компании отвечает требованиям в соответствии с ГОСТ Р ИСО 9001, ГОСТ РВ 0015-002 и ЭС РД 009

Офис по работе с юридическими лицами:

105318, г.Москва, ул.Щербаковская д.3, офис 1107, 1118, ДЦ «Щербаковский»

Телефон: +7 495 668-12-70 (многоканальный)

Факс: +7 495 668-12-70 (доб.304)

E-mail: info@moschip.ru

Skype отдела продаж:

moschip.ru

moschip.ru_4

moschip.ru_6

moschip.ru_9