

# EAC series

EAC -10 -472 -□

① ② ③ ④

- ① Model Name
- ② Rated Current
- ③ Line to ground capacitor code: See table 1.1.

table 1.1 Line to ground capacitor code

Code	Leakage Current (Input 125/250V 60Hz)	Line to ground capacitor (nominal value)
681	75.5 $\mu$ A/150 $\mu$ A max	680pF
102	0.13mA/0.25mA max	1000pF
222	0.25mA/0.5 mA max	2200pF
332	0.38mA/0.75mA max	3300pF
472	0.5 mA/1.0 mA max	4700pF

\* When the line to ground capacitor code is different, the attenuation characteristic is different.

④ Options  
D: DIN rail installation type

\* The dimensions change when the option is set. Refer to External view.



The terminal cover is retracted inside the unit

DIN rail installation type is option

## Features of EAC series

### Small, common mode EMI/EMC Filters in 150kHz to 1MHz(1-Stage filter)

- Single Phase 250 VAC
  - Small-size
  - Quick and easy push-down terminal
- Just connect the wires, push-down and tighten the screws with a screwdriver**

### Specifications

No.	Items	EAC-03-472	EAC-06-472	EAC-10-472	EAC-16-472	EAC-20-472	EAC-30-472
1	Rated Voltage[V]	AC 1 $\phi$ 250 / DC250					
2	Rated Current[A]	3	6	10	16	20	30
3	Test Voltage (Terminal-Mounting Plate)	2,500 VAC (Cutoff Current = 20mA), 1minute at room temperature and humidity					
4	Isolation Resistance (Terminal-Mounting Plate)	500 VDC 500M $\Omega$ min at room temperature and humidity					
5	Leakage current 125/250V 60Hz	0.5mA/1.0mA max					
6	DC resistance	180m $\Omega$ max	110m $\Omega$ max	40m $\Omega$ max	20m $\Omega$ max	10m $\Omega$ max	6m $\Omega$ max
7	Safety agency approval temperatures	-25 to +85 $^{\circ}$ C (Refer to Derating Curve)					
8	Operating temperature	-40 to +85 $^{\circ}$ C (Refer to Derating Curve)					
9	Operating humidity	20 to 95%RH (Non condensing)					
10	Storage temperature/humidity	-40 to +85 $^{\circ}$ C/20 to 95%RH (Non condensing)					
11	Vibration	10 to 55Hz, 19.6m/s $^2$ (2G), 3min. Period, 1hour each X, Y and Z axis					
12	Impact	196.1m/s $^2$ (20G), 11ms Once each X, Y and Z axis					
13	Safety agency approvals	UL1283, CSA C22.2 No.8 (C-UL), DIN EN60939 VDE0565 Teil3-1, ENEC (At only AC input)					
14	Case size (without projection) /Weight	39X30X85 mm [1.54X1.18X3.35 inches] (W X H X D) /170g max (Option : -D refer to external view)					

### Circuit Diagram

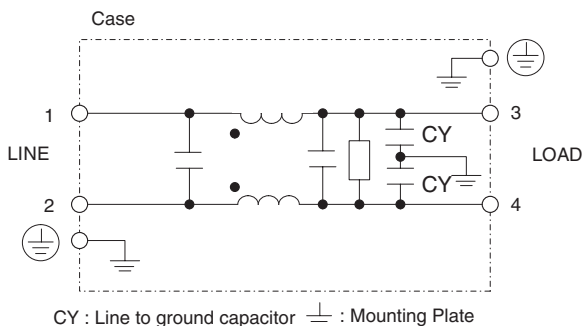

### Derating Curve

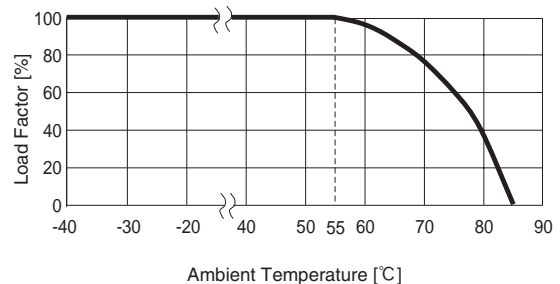

## External view

This product is shipped in the following condition, because it is equipped with push-down terminals.

- ① The terminal cover is retracted inside the unit.
- ② The screws for connecting the terminals are held in the up right position.

### Standard Type



### DIN rail installation Type



### ■Note when installing the EMI/EMC Filter on a DIN rail.

When the EMI/EMC Filter is grounded through the DIN rail, the proper noise attenuation may not be achieved.

Be sure to connect the protection earth (PE) of the EMI/EMC Filter body to the earth.

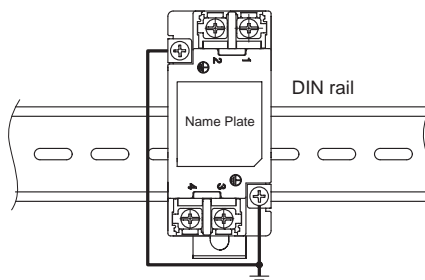

# Mouser Electronics

Authorized Distributor

Click to View Pricing, Inventory, Delivery & Lifecycle Information:

## Cosel:

[EAC-30-332-D](#) [EAC-30-472](#) [EAC-30-472-D](#) [EAC-30-681](#) [EAC-30-681-D](#) [EAC-20-681-D](#) [EAC-30-102](#) [EAC-30-102-D](#)  
[EAC-30-222](#) [EAC-30-222-D](#) [EAC-30-332](#) [EAC-20-222-D](#) [EAC-20-332](#) [EAC-20-332-D](#) [EAC-20-472](#) [EAC-20-472-D](#)  
[EAC-20-681](#) [EAC-16-472-D](#) [EAC-16-681](#) [EAC-16-681-D](#) [EAC-20-102](#) [EAC-20-102-D](#) [EAC-20-222](#) [EAC-16-102-D](#)  
[EAC-16-222](#) [EAC-16-222-D](#) [EAC-16-332](#) [EAC-16-332-D](#) [EAC-16-472](#) [EAC-10-332-D](#) [EAC-10-472](#) [EAC-10-472-D](#)  
[EAC-10-681](#) [EAC-10-681-D](#) [EAC-16-102](#) [EAC-06-681-D](#) [EAC-10-102](#) [EAC-10-102-D](#) [EAC-10-222](#) [EAC-10-222-D](#)  
[EAC-10-332](#) [EAC-06-222-D](#) [EAC-06-332](#) [EAC-06-332-D](#) [EAC-06-472](#) [EAC-06-472-D](#) [EAC-06-681](#) [EAC-03-472-D](#)  
[EAC-03-681](#) [EAC-03-681-D](#) [EAC-06-102](#) [EAC-06-102-D](#) [EAC-06-222](#) [EAC-03-102-D](#) [EAC-03-222](#) [EAC-03-222-D](#)  
[EAC-03-332](#) [EAC-03-332-D](#) [EAC-03-472](#) [EAC-03-102](#)

## Данный компонент на территории Российской Федерации

### Вы можете приобрести в компании MosChip.

Для оперативного оформления запроса Вам необходимо перейти по данной ссылке:

<http://moschip.ru/get-element>

Вы можете разместить у нас заказ для любого Вашего проекта, будь то серийное производство или разработка единичного прибора.

В нашем ассортименте представлены ведущие мировые производители активных и пассивных электронных компонентов.

Нашей специализацией является поставка электронной компонентной базы двойного назначения, продукции таких производителей как XILINX, Intel (ex.ALTERA), Vicor, Microchip, Texas Instruments, Analog Devices, Mini-Circuits, Amphenol, Glenair.

Сотрудничество с глобальными дистрибьюторами электронных компонентов, предоставляет возможность заказывать и получать с международных складов практически любой перечень компонентов в оптимальные для Вас сроки.

На всех этапах разработки и производства наши партнеры могут получить квалифицированную поддержку опытных инженеров.

Система менеджмента качества компании отвечает требованиям в соответствии с ГОСТ Р ИСО 9001, ГОСТ РВ 0015-002 и ЭС РД 009

### Офис по работе с юридическими лицами:

105318, г.Москва, ул.Щербаковская д.3, офис 1107, 1118, ДЦ «Щербаковский»

Телефон: +7 495 668-12-70 (многоканальный)

Факс: +7 495 668-12-70 (доб.304)

E-mail: [info@moschip.ru](mailto:info@moschip.ru)

Skype отдела продаж:

moschip.ru

moschip.ru\_4

moschip.ru\_6

moschip.ru\_9