

NCP331

Soft-Start Controlled Load Switch with Auto Discharge

The NCP331 is a low $R_{DS(on)}$ N-channel MOSFET controlled by a soft-start sequence of 2 ms for mobile applications. The very low $R_{DS(on)}$ allows system supplying or battery charging up to DC 2A. The device is enable due to external, active high, enable pin.

Due to a current consumption optimization, leakage current is drastically decreased from the battery connected to the device, allowing long battery life.

Features

- 1.8 V – 5.5 V Operating Range
- 33 mΩ N MOSFET
- DC Current Up to 2 A
- Peak Current Up to 5 A
- Built-in Soft-Start 2 ms
- Reverse Voltage Protection
- Output Discharge
- EN Logic Pin: Active High
- ESD Ratings:
Machine Model = B
Human Body Model = 2
- TSOP23–6 package
- This is a Pb–Free Device

Typical Applications

- Mobile Phones
- Tablets
- Digital Cameras
- GPS
- Computers



ON Semiconductor®

<http://onsemi.com>



**TSOP-6
SN SUFFIX
CASE 318G**

MARKING DIAGRAM

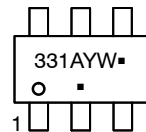

331 = Specific Device Code
A = Assembly Location
Y = Year
W = Work Week
▪ = Pb-Free Package

(Note: Microdot may be in either location)

PINOUT DIAGRAM

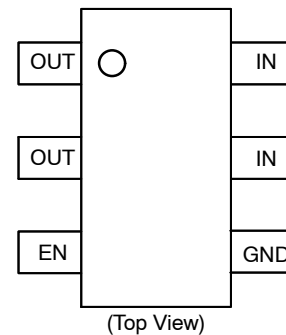

ORDERING INFORMATION

See detailed ordering and shipping information on page 7 of this data sheet.

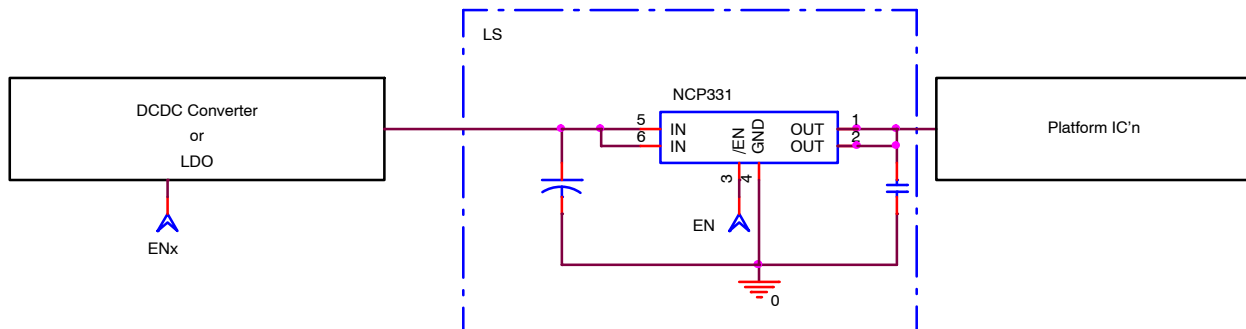

Figure 1. Typical Application Circuit

NCP331

PIN FUNCTION DESCRIPTION

Pin Name	Pin Number	Type	Description
IN	5,6	POWER	Power-switch input voltage; connect a 0.1 μF or greater ceramic capacitor from IN to GND as close as possible to the IC.
GND	4	POWER	Ground connection.
EN	3	INPUT	Enable input, logic high turns on power switch.
OUT	1,2	OUTPUT	Power-switch output; connect a 0.1 μF ceramic capacitor from OUT to GND as close as possible to the IC is recommended.

BLOCK DIAGRAM

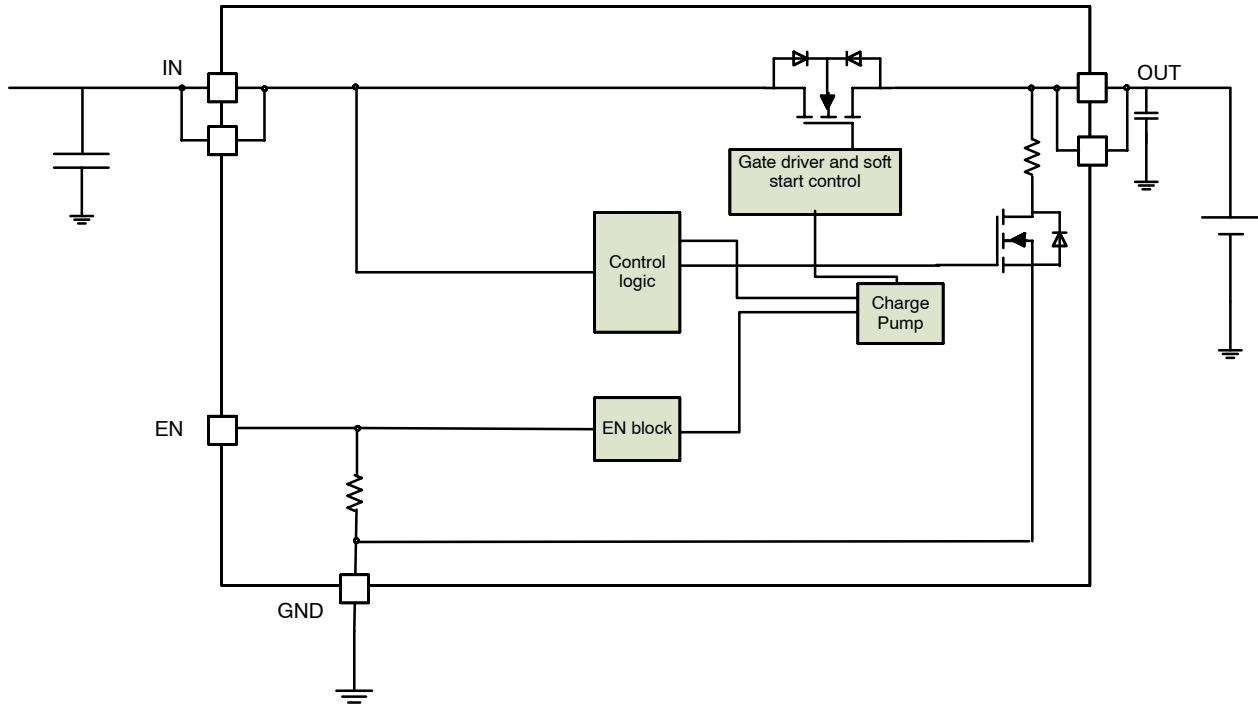

Figure 2. Block Diagram

NCP331

MAXIMUM RATINGS

Rating	Symbol	Value	Unit
IN, OUT, EN, Pins:	V_{EN}, V_{IN}, V_{OUT}	-0.3 to +7.0	V
From IN to OUT Pins: Input/Output	V_{IN}, V_{OUT}	-7.0 to +7.0	V
Maximum Junction Temperature Range	T_J	-40 to +125	°C
Storage Temperature Range	T_{STG}	-40 to +150	°C
ESD Withstand Voltage Human Body model (HBM), model = 2, Machine Model (MM) model = B, (Note 1)	V_{esd}	2500 200	V
Moisture Sensitivity (Note 2)	MSL	Level 1	

Stresses exceeding those listed in the Maximum Ratings table may damage the device. If any of these limits are exceeded, device functionality should not be assumed, damage may occur and reliability may be affected.

1. According to JEDEC standard JESD22-A108.
2. Moisture Sensitivity Level (MSL): 1 per IPC/JEDEC standard: J-STD-020.

OPERATING CONDITIONS

Symbol	Parameter	Conditions	Min	Typ	Max	Unit
V_{IN}	Operational Power Supply		1.8		5.5	V
V_{EN}	Enable Voltage		0		5.5	
T_A	Ambient Temperature Range		-40	25	+ 85	°C
T_J	Junction Temperature Range		-40	25	+ 125	°C
C_{IN}	Decoupling Input Capacitor		0.1			μF
C_{OUT}	Decoupling Output Capacitor		0.1			μF
$R_{\theta JA}$	Thermal Resistance – Junction-to-Air	(Notes 3 and 4)		305		°C/W
I_{OUT}	Maximum DC Current				2	A
P_D	Power Dissipation Rating (Note 7)	$T_A \leq 25^\circ\text{C}$		0.37		W
		$T_A = 85^\circ\text{C}$		0.13		W

Functional operation above the stresses listed in the Recommended Operating Ranges is not implied. Extended exposure to stresses beyond the Recommended Operating Ranges limits may affect device reliability.

3. The $R_{\theta JA}$ is dependent of the PCB heat dissipation.
4. The maximum power dissipation (P_D) is given by the following formula:

NCP331

ELECTRICAL CHARACTERISTICS Min & Max Limits apply for T_A between -40°C to $+85^{\circ}\text{C}$ and T_J up to $+125^{\circ}\text{C}$ for V_{IN} between 1.8 V to 5.5 V (Unless otherwise noted). Typical values are referenced to $T_A = +25^{\circ}\text{C}$ and $V_{IN} = 5\text{ V}$.

Symbol	Parameter	Conditions	Min	Typ	Max	Unit
--------	-----------	------------	-----	-----	-----	------

POWER SWITCH

$R_{DS(on)}$	Static drain-source on-state resistance	$V_{IN} = 3\text{ V}, V_{IN} = 5\text{ V},$ TSOP package	$T_J = 25^{\circ}\text{C}$		33		m Ω
			$-40^{\circ}\text{C} < T_J < 125^{\circ}\text{C}$			60	
T_{EN}	Gate turn on	$V_{IN} = 3.3\text{ V}$	From EN V_{ih} to V_{OUT} rising. (Note 5), $C_{LOAD} = 0.1\ \mu\text{F}, R_{LOAD} = 10\ \Omega$		60	200	μs
		$V_{IN} = 3.0\text{ V}$	From EN V_{ih} to 10% V_{OUT} rising. $C_{LOAD} = 1\ \mu\text{F}, R_{LOAD} = 25\ \Omega$		278	500	μs
T_R	Output rise time	$V_{IN} = 3.3\text{ V}$	$C_{LOAD} = 0.1\ \mu\text{F}, R_{LOAD} = 10\ \Omega$ (Note 5), from En to 95% V_{OUT}	1.2	2.05	3	ms
		$V_{IN} = 3.0\text{ V}$	$C_{LOAD} = 1\ \mu\text{F}, R_{LOAD} = 25\ \Omega$ (Note 6), from 10% to 90% V_{OUT}	1.00	1.65	2.36	
T_{dis}	Disable time	$V_{IN} = 3.0\text{ V}$	From EN high to low to V_{OUT} falling		0.3		
T_F	Output fall time	$V_{IN} = 3\text{ V}$	$C_{LOAD} = 1\ \mu\text{F}, R_{LOAD} = 25\ \Omega$ (Note 6)	0.1	0.18	0.5	
T_{OFF}	Output off time	$V_{IN} = 3\text{ V}$	$C_{LOAD} = 1\ \mu\text{F}, R_{LOAD} = 25\ \Omega$ (Notes 6 & 7), from EN to 10% V_{OUT}	0.3	0.5	0.8	

ENABLE INPUT EN

V_{IH}	High-level input voltage		1.15			V
V_{IL}	Low-level input voltage				0.85	V
R_{pd}	En pull-down resistor		1.1	1.5	1.8	M Ω
R_{dis}	Output discharge resistor		200	400	600	Ω

REVERSE-LEAKAGE PROTECTION

I_{REV}	Reverse-current protection	$V_{IN} = 0\text{ V}, V_{OUT} = 4.2\text{ V}$ (part disable), $T_A = 25^{\circ}\text{C}$		0.3	1.2	μA
-----------	----------------------------	--	--	-----	-----	---------------

QUIESCENT CURRENT

I_{stb}	Standby current	En low, $V_{in} = 3\text{ V}$		1.3	3	μA
I_q	Current consumption	No load, En high, $V_{in} = 3\text{ V}$		11	15	μA

Product parametric performance is indicated in the Electrical Characteristics for the listed test conditions, unless otherwise noted. Product performance may not be indicated by the Electrical Characteristics if operated under different conditions.

5. Guaranteed by correlation with 3.0 V production test.

6. Parameters are guaranteed for C_{LOAD} and R_{LOAD} connected to the OUT pin with respect to the ground.

7. Guaranteed by T_{fall} and $R_{discharge}$ tests.

NCP331

TIMINGS

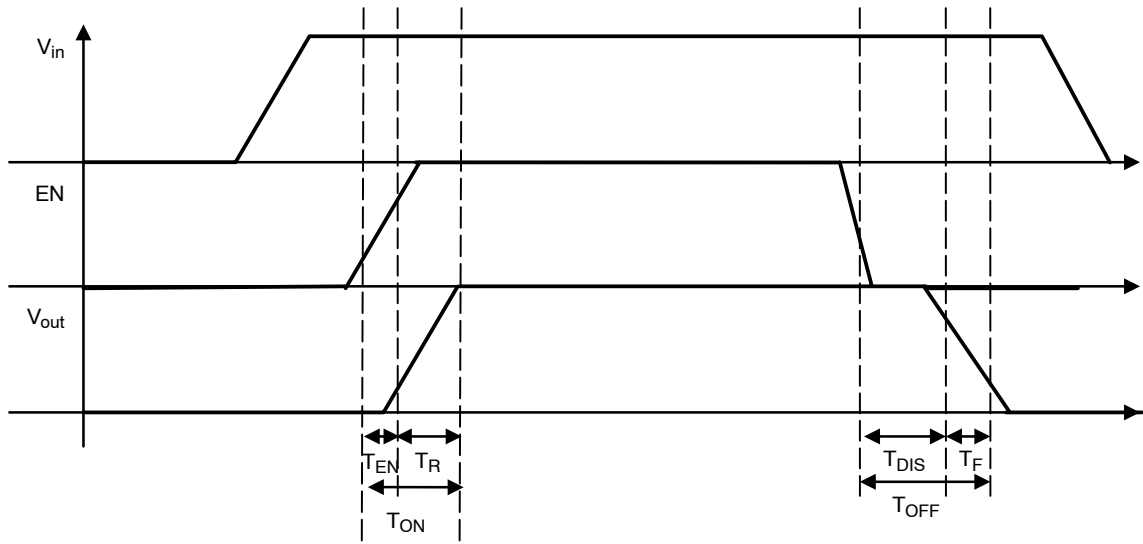

Figure 3. Timings

NCP331

TYPICAL CHARACTERISTICS

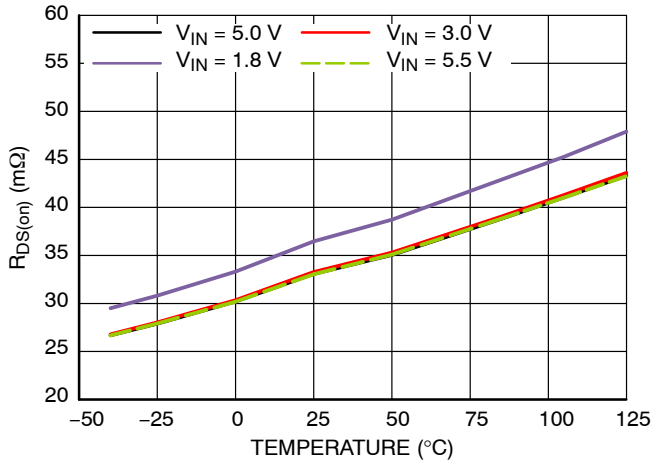

Figure 4. $R_{DS(on)}$ versus Temperature

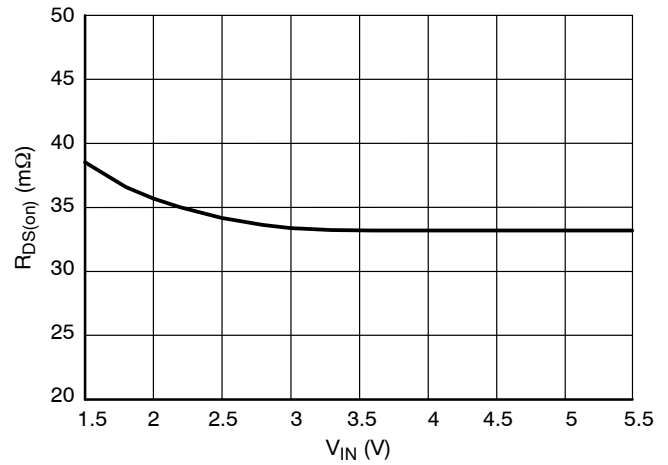

Figure 5. $R_{DS(on)}$ versus Input Voltage, Ambient Temperature

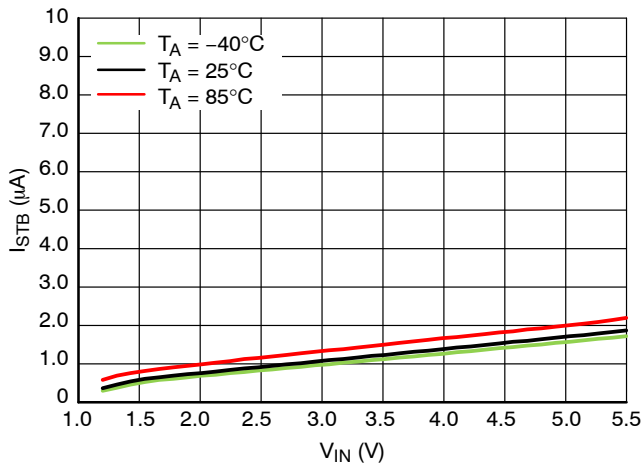

Figure 6. Standby Current versus Input Voltage

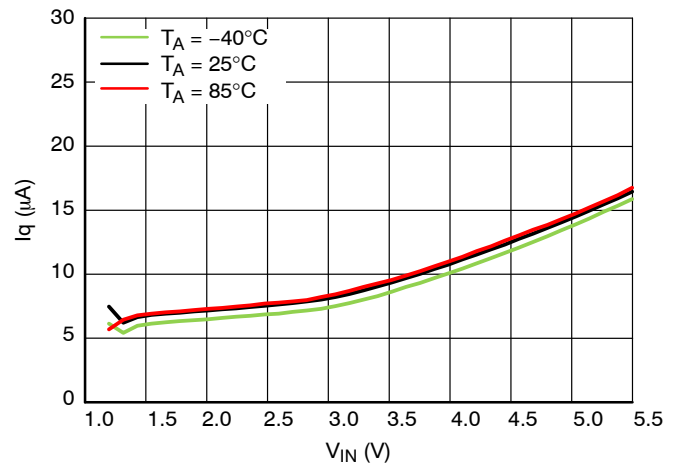

Figure 7. Quiescent Current versus Input Voltage

NCP331

FUNCTIONAL DESCRIPTION

Overview

The NCP331 is a high side N channel MOSFET power distribution switch designed to connect external voltage directly to the system.

Enable Input

Enable pin is an active high.

The part is in disable mode when EN is tied to low. Power MOSFET is opened. Pull down resistor is placed to maintained the part off if En pin is not externally driven.

The parts becomes in enable mode if EN is tied high and Power MOSFET is turned of after ten and t_{rise} times.

Auto Discharge

NMOS FET is placed between the output pin and GND, in order to discharge the application capacitor connected on OUT pin.

The auto-discharge is activated when EN pin is set to low level (disable state).

The discharge path (Pull down NMOS) stays activated as long as EN pin is set at low level.

Blocking Control

The blocking control circuitry switches the bulk of the power NMOS. When the part is off (No V_{in} or EN tied to GND externally), the body diode limits the leakage current I_{REV} from OUT to IN. In this mode, anode of the body diode is connected to IN pin and cathode is connected to OUT pin. In operating condition, anode of the body diode is connected to OUT pin and cathode is connected to IN pin preventing the discharge of the power supply.

APPLICATION INFORMATION

Power Dissipation

The device's junction temperature depends on different contributor factor such as board layout, ambient temperature, device environment, etc... Yet, the main contributor in term of junction temperature is the power dissipation of the power MOSFET. Assuming this, the power dissipation and the junction temperature in normal mode can be calculated with the following equations:

$$P_D = R_{DS(on)} \times (I_{OUT})^2$$

P_D = Power dissipation (W)
 $R_{DS(on)}$ = Power MOSFET on resistance (Ω)
 I_{OUT} = Output current (A)

$$T_J = P_D \times R_{\theta JA} + T_A$$

T_J = Junction temperature ($^{\circ}C$)
 $R_{\theta JA}$ = Package thermal resistance ($^{\circ}C/W$)
 T_A = Ambient temperature ($^{\circ}C$)

PCB Recommendations

The NCP331 integrates an up to 2A rated NMOS FET, and the PCB design rules must be respected to properly evacuate the heat out of the silicon. By increasing PCB area, the $R_{\theta JA}$ of the package can be decreased, allowing higher power dissipation.

ORDERING INFORMATION

Device	Marking	Package	Shipping [†]
NCP331SNT1G	331	TSOP-6 (Pb-Free)	3000 / Tape & Reel

[†]For information on tape and reel specifications, including part orientation and tape sizes, please refer to our Tape and Reel Packaging Specifications Brochure, BRD8011/D.

NCP331

PACKAGE DIMENSIONS

TSOP-6 CASE 318G-02 ISSUE V

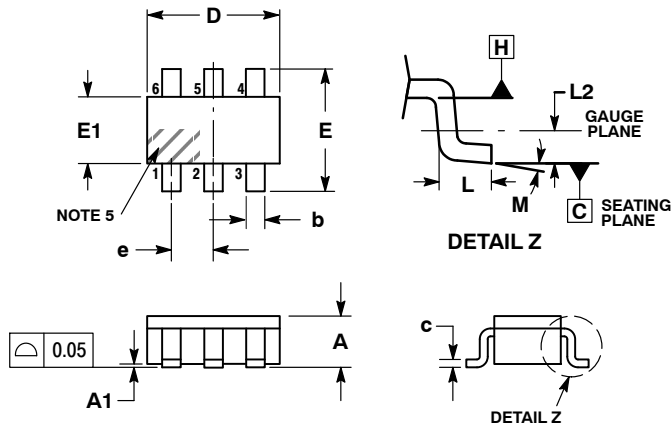

NOTES:

1. DIMENSIONING AND TOLERANCING PER ASME Y14.5M, 1994.
2. CONTROLLING DIMENSION: MILLIMETERS.
3. MAXIMUM LEAD THICKNESS INCLUDES LEAD FINISH. MINIMUM LEAD THICKNESS IS THE MINIMUM THICKNESS OF BASE MATERIAL.
4. DIMENSIONS D AND E1 DO NOT INCLUDE MOLD FLASH, PROTRUSIONS, OR GATE BURRS. MOLD FLASH, PROTRUSIONS, OR GATE BURRS SHALL NOT EXCEED 0.15 PER SIDE. DIMENSIONS D AND E1 ARE DETERMINED AT DATUM H.
5. PIN ONE INDICATOR MUST BE LOCATED IN THE INDICATED ZONE.

DIM	MILLIMETERS		
	MIN	NOM	MAX
A	0.90	1.00	1.10
A1	0.01	0.06	0.10
b	0.25	0.38	0.50
c	0.10	0.18	0.26
D	2.90	3.00	3.10
E	2.50	2.75	3.00
E1	1.30	1.50	1.70
e	0.85	0.95	1.05
L	0.20	0.40	0.60
L2	0.25 BSC		
M	0°	-	10°

RECOMMENDED SOLDERING FOOTPRINT*

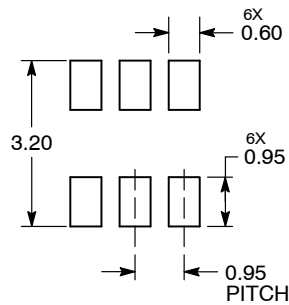

DIMENSIONS: MILLIMETERS

*For additional information on our Pb-Free strategy and soldering details, please download the ON Semiconductor Soldering and Mounting Techniques Reference Manual, SOLDERRM/D.

ON Semiconductor and  are registered trademarks of Semiconductor Components Industries, LLC (SCILLC). SCILLC owns the rights to a number of patents, trademarks, copyrights, trade secrets, and other intellectual property. A listing of SCILLC's product/patent coverage may be accessed at www.onsemi.com/site/pdf/Patent-Marketing.pdf. SCILLC reserves the right to make changes without further notice to any products herein. SCILLC makes no warranty, representation or guarantee regarding the suitability of its products for any particular purpose, nor does SCILLC assume any liability arising out of the application or use of any product or circuit, and specifically disclaims any and all liability, including without limitation special, consequential or incidental damages. "Typical" parameters which may be provided in SCILLC data sheets and/or specifications can and do vary in different applications and actual performance may vary over time. All operating parameters, including "Typicals" must be validated for each customer application by customer's technical experts. SCILLC does not convey any license under its patent rights nor the rights of others. SCILLC products are not designed, intended, or authorized for use as components in systems intended for surgical implant into the body, or other applications intended to support or sustain life, or for any other application in which the failure of the SCILLC product could create a situation where personal injury or death may occur. Should Buyer purchase or use SCILLC products for any such unintended or unauthorized application, Buyer shall indemnify and hold SCILLC and its officers, employees, subsidiaries, affiliates, and distributors harmless against all claims, costs, damages, and expenses, and reasonable attorney fees arising out of, directly or indirectly, any claim of personal injury or death associated with such unintended or unauthorized use, even if such claim alleges that SCILLC was negligent regarding the design or manufacture of the part. SCILLC is an Equal Opportunity/Affirmative Action Employer. This literature is subject to all applicable copyright laws and is not for resale in any manner.

PUBLICATION ORDERING INFORMATION

LITERATURE FULFILLMENT:

Literature Distribution Center for ON Semiconductor
P.O. Box 5163, Denver, Colorado 80217 USA
Phone: 303-675-2175 or 800-344-3860 Toll Free USA/Canada
Fax: 303-675-2176 or 800-344-3867 Toll Free USA/Canada
Email: orderlit@onsemi.com

N. American Technical Support: 800-282-9855 Toll Free
USA/Canada
Europe, Middle East and Africa Technical Support:
Phone: 421 33 790 2910
Japan Customer Focus Center
Phone: 81-3-5817-1050

ON Semiconductor Website: www.onsemi.com

Order Literature: <http://www.onsemi.com/orderlit>

For additional information, please contact your local Sales Representative

Данный компонент на территории Российской Федерации

Вы можете приобрести в компании MosChip.

Для оперативного оформления запроса Вам необходимо перейти по данной ссылке:

<http://moschip.ru/get-element>

Вы можете разместить у нас заказ для любого Вашего проекта, будь то серийное производство или разработка единичного прибора.

В нашем ассортименте представлены ведущие мировые производители активных и пассивных электронных компонентов.

Нашей специализацией является поставка электронной компонентной базы двойного назначения, продукции таких производителей как XILINX, Intel (ex.ALTERA), Vicor, Microchip, Texas Instruments, Analog Devices, Mini-Circuits, Amphenol, Glenair.

Сотрудничество с глобальными дистрибьюторами электронных компонентов, предоставляет возможность заказывать и получать с международных складов практически любой перечень компонентов в оптимальные для Вас сроки.

На всех этапах разработки и производства наши партнеры могут получить квалифицированную поддержку опытных инженеров.

Система менеджмента качества компании отвечает требованиям в соответствии с ГОСТ Р ИСО 9001, ГОСТ РВ 0015-002 и ЭС РД 009

Офис по работе с юридическими лицами:

105318, г.Москва, ул.Щербаковская д.3, офис 1107, 1118, ДЦ «Щербаковский»

Телефон: +7 495 668-12-70 (многоканальный)

Факс: +7 495 668-12-70 (доб.304)

E-mail: info@moschip.ru

Skype отдела продаж:

moschip.ru

moschip.ru_4

moschip.ru_6

moschip.ru_9