

FEATURES

- 100% Tested Settling Time to 1mV at Sum Node, 10V Step Tested with Fixed Feedback Capacitor

340ns Typ
540ns Max
- Slew Rate

60V/μs Min

- Gain-Bandwidth Product

14MHz

- Power Bandwidth (20V_{P-P})

1.2 MHz

- Unity-Gain Stable; Phase Margin

60°

- Input Offset Voltage

600μV Max

- Input Bias Current

25°C 75pA Max
70°C 600pA Max
- Input Offset Current

25°C 40pA Max
70°C 150pA Max
- Low Distortion

APPLICATIONS

- Fast 12-Bit D/A Output Amplifiers
- High Speed Buffers
- Fast Sample-and-Hold Amplifiers
- High Speed Integrators
- Voltage to Frequency Converters
- Active Filters
- Log Amplifiers
- Peak Detectors

DESCRIPTION

The **LT[®]1122** JFET input operational amplifier combines high speed and precision performance.

A unique poly-gate JFET process minimizes gate series resistance and gate-to-drain capacitance, facilitating wide bandwidth performance, without degrading JFET transistor matching.

It slews at 80V/μs and settles in 340ns. The LT1122 is internally compensated to be unity-gain stable, yet it has a bandwidth of 14MHz at a supply current of only 7mA. Its speed makes the LT1122 an ideal choice for fast settling 12-bit data conversion and acquisition systems.

The LT1122 offset voltage of 120μV, and voltage gain of 500,000 also support the 12-bit accurate applications.

The input bias current of 10pA and offset current of 4pA combined with its speed allow the LT1122 to be used in such applications as high speed sample and hold amplifiers, peak detectors, and integrators.

LT, LT, LTC, LTM, Linear Technology and the Linear logo are registered trademarks and C-Load is a trademark of Linear Technology Corporation. All other trademarks are the property of their respective owners.

TYPICAL APPLICATION

12-Bit Voltage Output D/A Converter

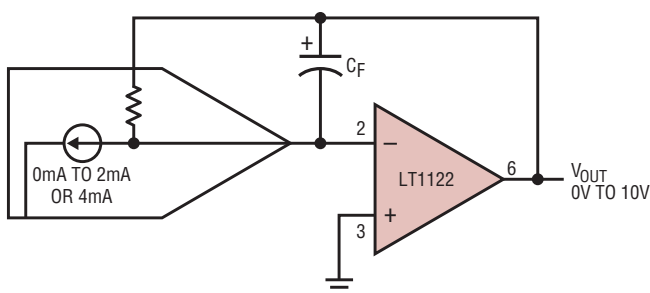

12-BIT CURRENT OUTPUT D/A CONVERTER
 $C_F = 5\text{pF TO } 17\text{pF}$
 (DEPENDENT ON D/A CONVERTER USED)

LT1122-TA01

Large-Scale Response

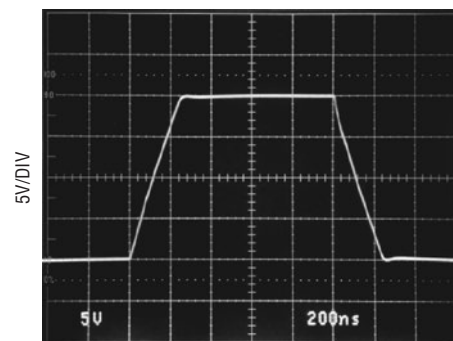

200ns/DIV
 $A_V = -1$

1122 TA07

LT1122

ABSOLUTE MAXIMUM RATINGS (Note 1)

Supply Voltage	±20V	Operating Temperature Range	
Differential Input Voltage	±40V	LT1122AM/BM/CM/DM (OBSOLETE)..	-55°C to 125°C
Input Voltage.....	±20V	LT1122AC/BC/CC/DC/CS/DS	-40°C to 85°C
Output Short Circuit Duration	Indefinite	Storage Temperature Range	
Lead Temperature (Soldering, 10 sec.).....	300°C	All Devices	-65°C to 150°C

PIN CONFIGURATION

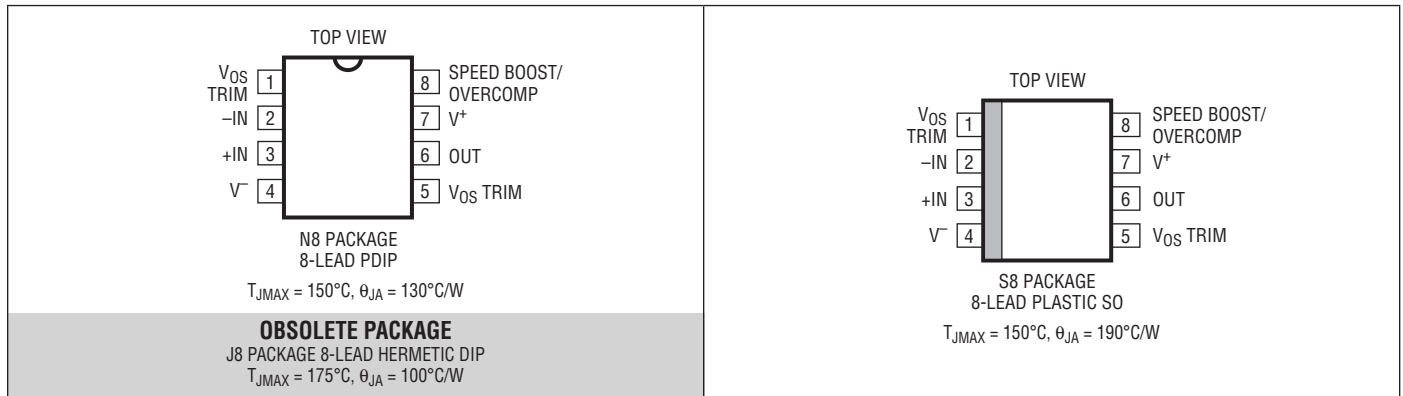

ORDER INFORMATION

LEAD FREE FINISH	TAPE AND REEL	PART MARKING	PACKAGE DESCRIPTION	TEMPERATURE RANGE
LT1122ACN8#PBF	LT1122ACN8#TRPBF	LT1122ACN8	8-Lead Plastic DIP	-40°C to 85°C
LT1122BCN8#PBF	LT1122BCN8#TRPBF	LT1122BCN8	8-Lead Plastic DIP	-40°C to 85°C
LT1122CCN8#PBF	LT1122CCN8#TRPBF	LT1122CCN8	8-Lead Plastic DIP	-40°C to 85°C
LT1122DCN8#PBF	LT1122DCN8#TRPBF	LT1122DCN8	8-Lead Plastic DIP	-40°C to 85°C
LT1122CS8#PBF	LT1122CS8#TRPBF	1122C	8-Lead Plastic SO	-40°C to 85°C
LT1122DS8#PBF	LT1122DS8#TRPBF	1122D	8-Lead Plastic SO	-40°C to 85°C
OBSOLETE PACKAGE				
LT1122AMJ8#PBF	LT1122AMJ8#TRPBF	LT1122AMJ8	8-Lead Hermetic DIP	-55°C to 125°C
LT1122BMJ8#PBF	LT1122BMJ8#TRPBF	LT1122BMJ8	8-Lead Hermetic DIP	-55°C to 125°C
LT1122CMJ8#PBF	LT1122CMJ8#TRPBF	LT1122CMJ8	8-Lead Hermetic DIP	-55°C to 125°C
LT1122DMJ8#PBF	LT1122DMJ8#TRPBF	LT1122DMJ8	8-Lead Hermetic DIP	-55°C to 125°C
LT1122ACJ8#PBF	LT1122ACJ8#TRPBF	LT1122ACJ8	8-Lead Hermetic DIP	-40°C to 85°C
LT1122BCJ8#PBF	LT1122BCJ8#TRPBF	LT1122BCJ8	8-Lead Hermetic DIP	-40°C to 85°C
LT1122CCJ8#PBF	LT1122CCJ8#TRPBF	LT1122CCJ8	8-Lead Hermetic DIP	-40°C to 85°C
LT1122DCJ8#PBF	LT1122DCJ8#TRPBF	LT1122DCJ8	8-Lead Hermetic DIP	-40°C to 85°C

Consult LTC Marketing for parts specified with wider operating temperature ranges.
 Consult LTC Marketing for information on nonstandard lead based finish parts.

For more information on lead free part markings, go to: <http://www.linear.com/leadfree/>
 For more information on tape and reel specifications, go to: <http://www.linear.com/tapeandreeel/>

ELECTRICAL CHARACTERISTICS The ● denotes the specifications which apply over the full operating temperature range, otherwise specifications are at $T_A = 25^\circ\text{C}$. $V_S = \pm 15\text{V}$, $V_{CM} = 0\text{V}$ unless otherwise noted. (Note 2)

SYMBOL	PARAMETER	CONDITIONS	LT1122AM/BM LT1122AC/BC			LT1122CM/DM LT1122CC/DC LT1122CS/DS			UNITS	
			MIN	TYP	MAX	MIN	TYP	MAX		
V_{OS}	Input Offset Voltage		120	600		130	900		μV	
I_{OS}	Input Offset Current		4	40		5	50		pA	
I_B	Input Bias Current		10	75		12	100		pA	
	Input Resistance Differential		10^{12}			10^{12}				Ω
	Common Mode	$V_{CM} = -10\text{V to } 8\text{V}$	10^{12}			10^{12}				Ω
		$V_{CM} = 8\text{V to } 11\text{V}$	10^{11}			10^{11}				Ω
	Input Capacitance		4			4				pF
SR	Slew Rate	$A_V = -1$	60	80		50	75		$\text{V}/\mu\text{s}$	
	Settling Time (Note 2)	10V to 0V, -10V to 0V 100% Tested: A- and C-Grades to 1mV at Sum Node B- and D-Grades to 1mV at Sum Node All Grades to 0.5mV at Sum Node		340	540		350	590		ns
				350			360			ns
				450			470			ns
GBW	Gain-Bandwidth Product Power Bandwidth	$V_{OUT} = 20V_{P-P}$	14			13				MHz
			1.2			1.1				MHz
A_{VOL}	Large-Signal Voltage Gain	$V_{OUT} = \pm 10\text{V}$, $R_L = 2\text{k}\Omega$ $V_{OUT} = \pm 10\text{V}$, $R_L = 600\Omega$	180	500		150	450		V/mV	
			130	250		110	220		V/mV	
CMRR	Common-Mode Rejection Ratio	$V_{CM} = \pm 10\text{V}$	83	99		80	98		dB	
	Input Voltage Range	(Note 4)	± 10.5	± 11		± 10.5	± 11		V	
PSRR	Power Supply Rejection Ratio	$V_S = \pm 10\text{V to } \pm 18\text{V}$	86	103		82	101		dB	
	Input Noise Voltage	0.1Hz to 10Hz	3.0			3.3				μV_{P-P}
	Input Noise Voltage Density	$f_0 = 100\text{Hz}$ $f_0 = 10\text{kHz}$	25			27				$\text{nV}/\sqrt{\text{Hz}}$
			14			15				$\text{nV}/\sqrt{\text{Hz}}$
	Input Noise Current Density	$f_0 = 100\text{Hz}$, $f_0 = 10\text{kHz}$	2			2				$\text{fA}/\sqrt{\text{Hz}}$
V_{OUT}	Output Voltage Swing	$R_L = 2\text{k}\Omega$ $R_L = 600\Omega$	± 12	± 12.5		± 12	± 12.5		V	
			± 11.5	± 12		± 11.5	± 12		V	
I_S	Supply Current		7.5	10		7.8	11		mA	
	Minimum Supply Voltage	(Note 5)	± 5			± 5				V
	Offset Adjustment Range	$R_{POT} \geq 10\text{k}$, Wiper to V^+	± 4	± 10		± 4	± 10		mV	

ELECTRICAL CHARACTERISTICS

The ● denotes the specifications which apply over the full operating temperature range, otherwise specifications are at $0^{\circ}\text{C} \leq T_A \leq 70^{\circ}\text{C}$. $V_S = \pm 15\text{V}$, $V_{CM} = 0\text{V}$. (Note 2)

SYMBOL	PARAMETER	CONDITIONS	LT1122AC/BC			LT1122CC/DC LT1122CS/DS			UNITS
			MIN	TYP	MAX	MIN	TYP	MAX	
V_{OS}	Input Offset Voltage		●	350	1400		400	2000	μV
	Average Temperature Coefficient of Input Offset Voltage		●	5	18		6	25	$\mu\text{V}/^{\circ}\text{C}$
I_{OS}	Input Offset Current		●	12	150		15	200	pA
I_B	Input Bias Current		●	80	600		90	800	pA
A_{VOL}	Large-Signal Voltage Gain	$V_{OUT} = \pm 10\text{V}$, $R_L \geq 2\text{k}\Omega$	●	120	380		100	340	V/mV
CMRR	Common-Mode Rejection Ratio	$V_{CM} = \pm 10\text{V}$	●	82	98		78	96	dB
PSRR	Power Supply Rejection Ratio	$V_S = \pm 10\text{V}$ to $\pm 17\text{V}$	●	84	101		80	99	dB
	Input Voltage Range		●	± 10	± 10.8		± 10	± 10.8	V
V_{OUT}	Output Voltage Swing	$R_L = 2\text{k}\Omega$	●	± 11.5	± 12.4		± 11.5	± 12.4	V
SR	Slew Rate	$A_V = -1$	●	50	70		40	65	$\text{V}/\mu\text{s}$

The ● denotes the specifications which apply over the full operating temperature range, otherwise specifications are at $-55^{\circ}\text{C} \leq T_A \leq 125^{\circ}\text{C}$. $V_S = \pm 15\text{V}$, $V_{CM} = 0\text{V}$. (Note 2)

SYMBOL	PARAMETER	CONDITIONS	LT1122AM/BM			LT1122CS/DS			UNITS
			MIN	TYP	MAX	MIN	TYP	MAX	
V_{OS}	Input Offset Voltage		●	650	2400		800	3400	μV
	Average Temperature Coefficient of Input Offset Voltage		●	6	18		7	25	$\mu\text{V}/^{\circ}\text{C}$
I_{OS}	Input Offset Current		●	0.5	6		0.6	9	nA
I_B	Input Bias Current		●	6	25		7	35	nA
A_{VOL}	Large-Signal Voltage Gain	$V_{OUT} = \pm 10\text{V}$, $R_L \geq 2\text{k}\Omega$	●	70	230		60	200	V/mV
CMRR	Common-Mode Rejection Ratio	$V_{CM} = \pm 10\text{V}$	●	80	97		76	94	dB
PSRR	Power Supply Rejection Ratio	$V_S = \pm 10\text{V}$ to $\pm 17\text{V}$	●	83	100		78	98	dB
	Input Voltage Range		●	± 10	± 10.5		± 10	± 10.5	V
V_{OUT}	Output Voltage Swing	$R_L = 2\text{k}\Omega$	●	± 11.3	± 12.1		± 11.3	± 12.1	V
SR	Slew Rate	$A_V = -1$	●	45	60		35	55	$\text{V}/\mu\text{s}$

The ● denotes the specifications which apply over the full operating temperature range, otherwise specifications are at $-40^{\circ}\text{C} \leq T_A \leq 85^{\circ}\text{C}$. $V_S = \pm 15\text{V}$, $V_{CM} = 0\text{V}$. (Note 6)

SYMBOL	PARAMETER	CONDITIONS	LT1122AM/BM			LT1122CS/DS			UNITS
			MIN	TYP	MAX	MIN	TYP	MAX	
V_{OS}	Input Offset Voltage		●	450	1900		500	2700	μV
	Average Temperature Coefficient of Input Offset Voltage		●	6	20		7	28	$\mu\text{V}/^{\circ}\text{C}$
I_{OS}	Input Offset Current		●	30	600		40	900	pA
I_B	Input Bias Current		●	230	2000		260	2700	pA
A_{VOL}	Large-Signal Voltage Gain	$V_{OUT} = \pm 10\text{V}$, $R_L \geq 2\text{k}\Omega$	●	95	340		80	300	V/mV
CMRR	Common-Mode Rejection Ratio	$V_{CM} = \pm 10\text{V}$	●	80	98		76	96	dB
PSRR	Power Supply Rejection Ratio	$V_S = \pm 10\text{V}$ to $\pm 17\text{V}$	●	83	100		78	98	dB
	Input Voltage Range		●	± 10	± 10.6		± 10	± 10.6	V
V_{OUT}	Output Voltage Swing	$R_L = 2\text{k}\Omega$	●	± 11.3	± 12.2		± 11.3	± 12.2	V
SR	Slew Rate	$A_V = -1$	●	45	60		35	60	$\text{V}/\mu\text{s}$

ELECTRICAL CHARACTERISTICS

Note 1: Stresses beyond those listed under Absolute Maximum Ratings may cause permanent damage to the device. Exposure to any Absolute Maximum Rating condition for extended periods may affect device reliability and lifetime.

Note 2: The LT1122 is measured in an automated tester in less than one second after application of power. Depending on the package used, power dissipation, heat sinking, and air flow conditions, the fully warmed up chip temperature can be 10°C to 50°C higher than the ambient temperature.

Note 3: Settling time is 100% tested for A- and C-grades using the settling time test circuit shown. This test is not included in quality assurance sample testing.

Note 4: Input voltage range functionality is assured by testing offset voltage at the input voltage range limits to a maximum of 4mV (A, B grades), to 5.7mV (C, D grades).

Note 5: Minimum supply voltage is tested by measuring offset voltage to 7mV maximum at ±5V supplies.

Note 6: The LT1122 is not tested and not quality-assurance-sampled at -40°C and at 85°C. These specifications are guaranteed by design, correlation and/or inference from -55°C, 0°C, 25°C, 70°C and/or 125°C tests.

Settling Time Test Fixture

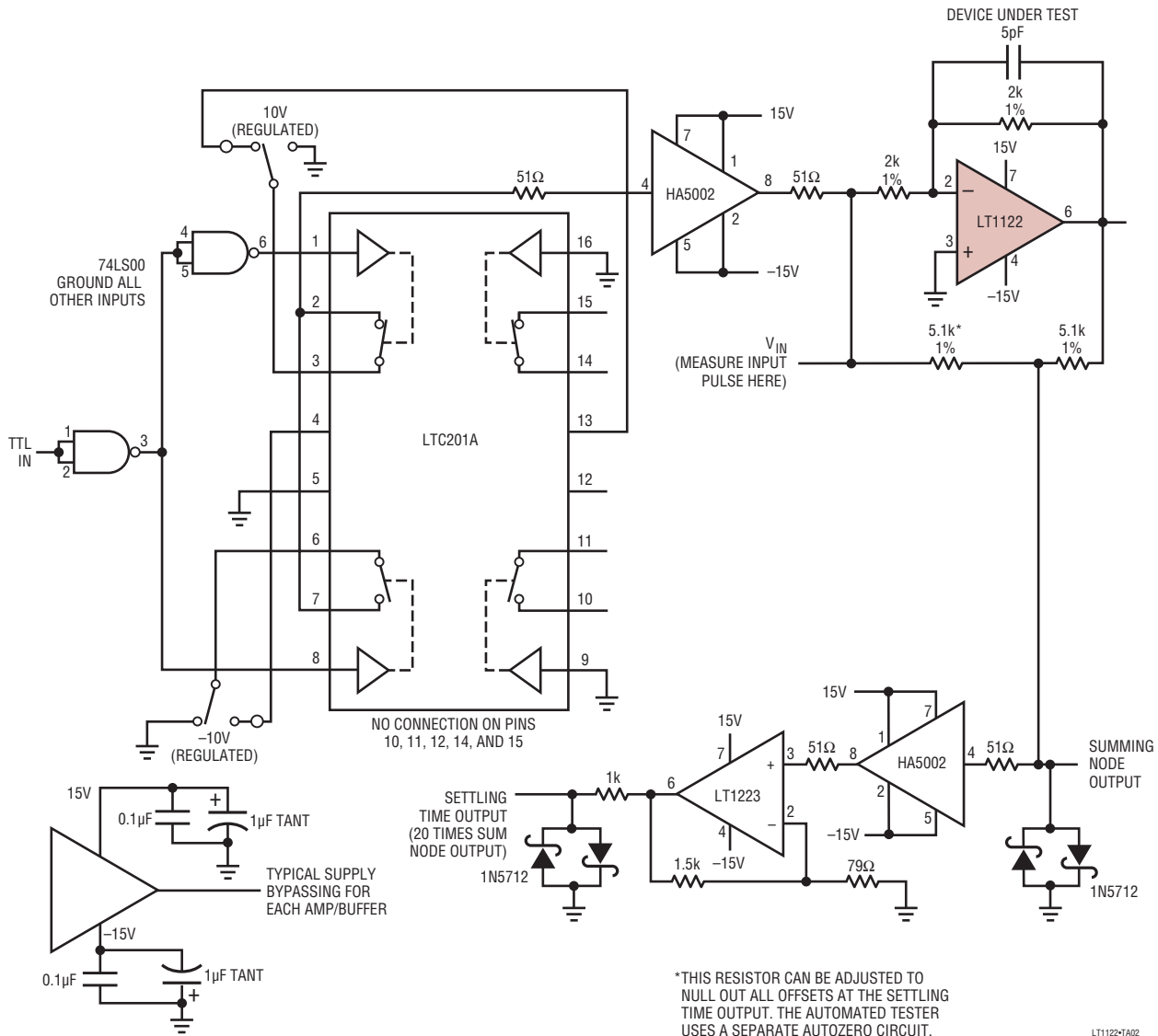

TYPICAL PERFORMANCE CHARACTERISTICS

Settling Time
(Input from -10V to 0V)

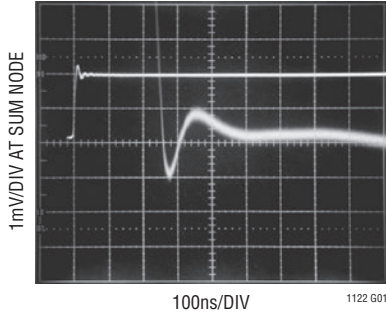

Settling Time
(Input from 10V to 0V)

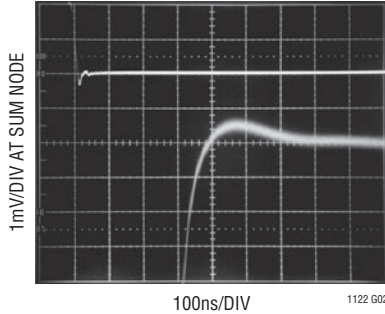

Settling Time
(Input from 0V to 10V)

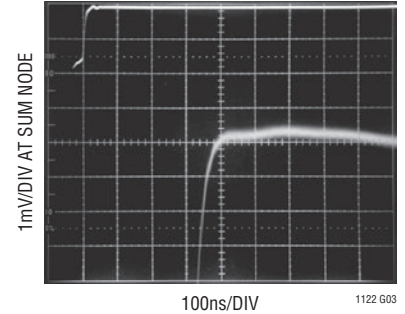

Settling Time
(Input from 0V to -10V)

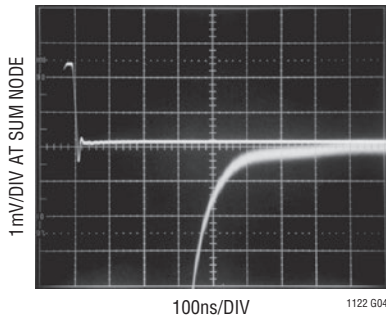

Large-Signal Response

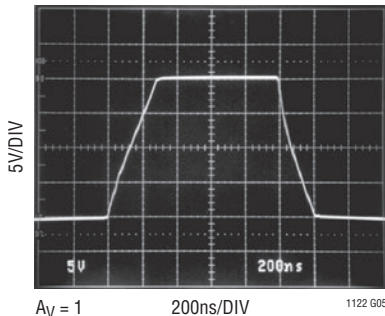

Undistorted Output Swing vs Frequency

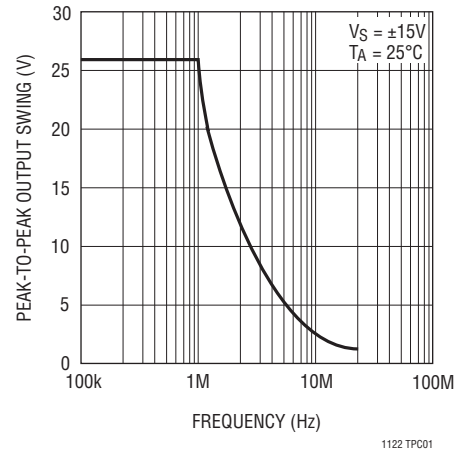

Voltage Gain vs Frequency

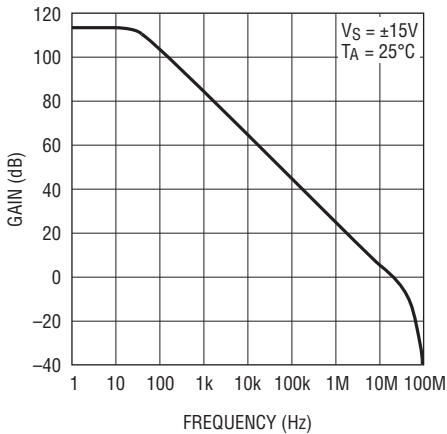

Gain, Phase vs Frequency

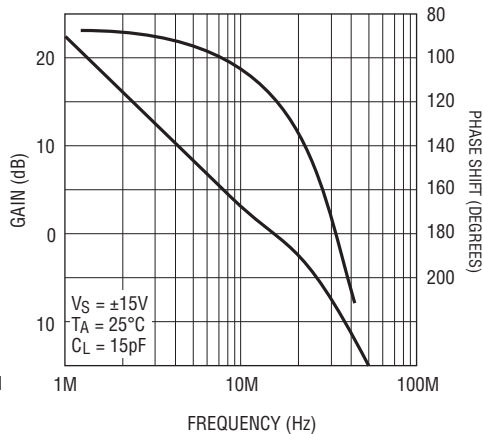

Common-Mode Rejection vs Frequency

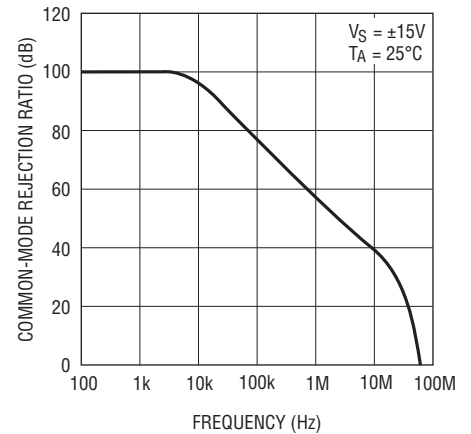

TYPICAL PERFORMANCE CHARACTERISTICS

Distribution of Input Offset Voltage

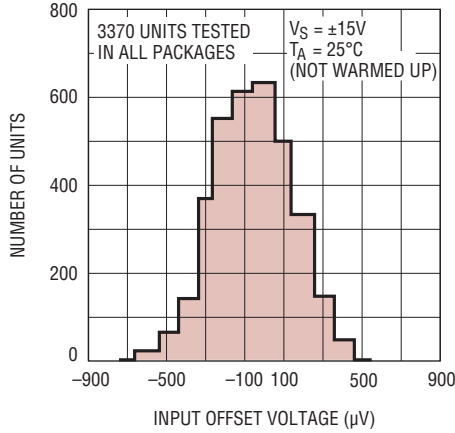

1122 TPC05

Input Bias and Offset Currents Over Temperature

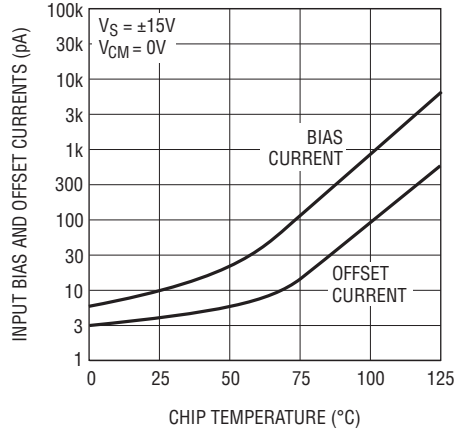

1122 TPC06

Bias and Offset Currents Over the Common-Mode Range

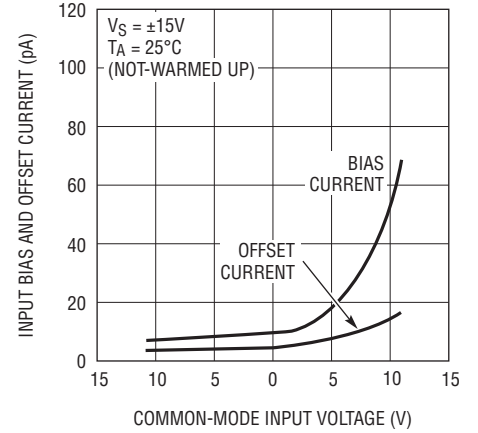

1122 TPC07

Warm-Up Drift

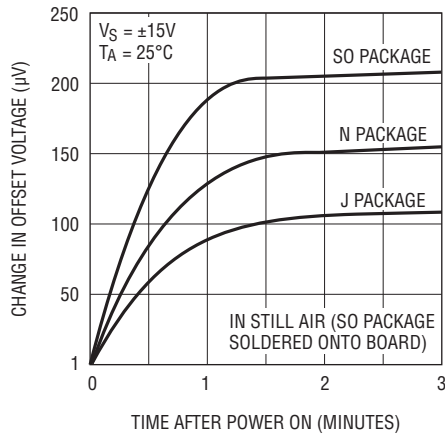

1122 TPC08

Noise Spectrum

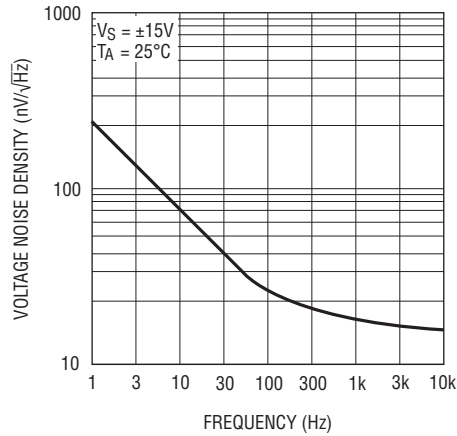

1122 TPC09

0.1Hz to 10Hz Noise

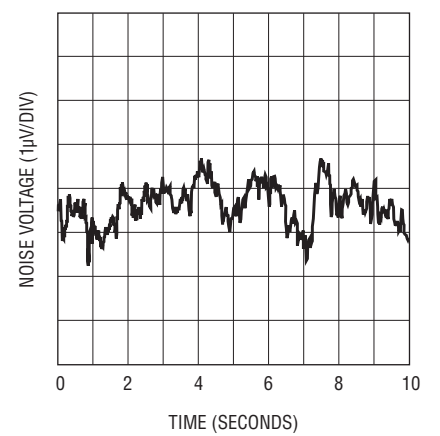

1122 TPC10

Total Harmonic Distortion + Noise vs Frequency Inverting Gain

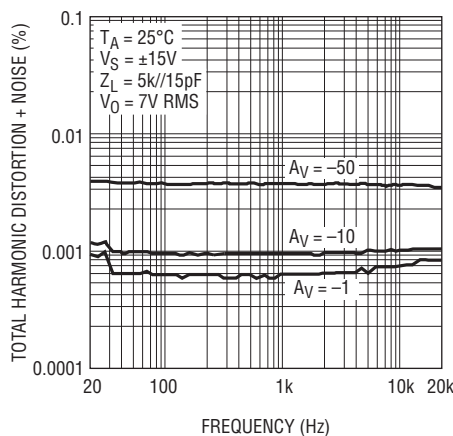

1122 TPC11

Total Harmonic Distortion + Noise vs Frequency Noninverting Gain

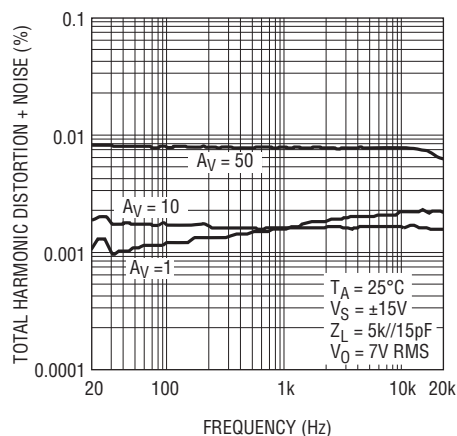

1122 TPC12

Intermodulation Distortion (CCIF Method) vs Frequency LT1122 and LF156*

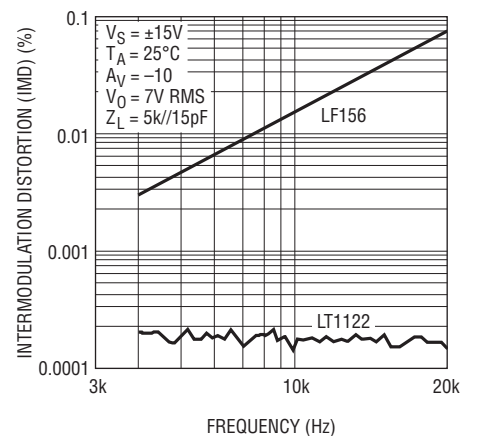

*SEE LT1115 DATA SHEET FOR DEFINITION OF CCIF TESTING

1122 TPC13
1122fb

APPLICATIONS INFORMATION

Settling Time Measurements

Settling time test circuits shown on some competitive devices' data sheets require:

1. A "flat top" pulse generator. Unfortunately, flat top pulse generators are not commercially available.
2. A variable feedback capacitor around the device under test. This capacitor varies over a four-to-one range. Presumably, as each op amp is measured for settling time, the capacitor is fine tuned to optimize settling time for that particular device.
3. A small inductor load to optimize settling.

The LT1122's settling time is 100% tested in the test circuit shown. No "flat top" pulse generator is required. The test circuit can be readily constructed, using commercially available ICs. Of course, standard high frequency board construction techniques should be followed. All LT1122s are measured with a constant feedback capacitor. No fine tuning is required.

Speed Boost/Overcompensation Terminal

Pin 8 of the LT1122 can be used to change the input stage operating current of the device. Shorting Pin 8 to the positive supply (Pin 7) increases slew rate and bandwidth by about 25%, but at the expense of a reduction in phase margin by approximately 18 degrees. Unity-gain capacitive load handling decreases from typically 500pF to 100pF.

Conversely, connecting a 15k resistor from Pin 8 to ground pulls 1mA out of Pin 8 (with $V^+ = 15V$). This reduces slew rate and bandwidth by 25%. Phase margin and capacitive load handling improve; the latter typically increasing to 800pF.

High Speed Operation

As with most high speed amplifiers, care should be taken with supply decoupling, lead dress and component placement.

The power supply connections to the LT1122 must maintain a low impedance to ground over a bandwidth of 20MHz. This is especially important when driving a significant resistive or capacitive load, since all current delivered to the load comes from the power supplies. Multiple high quality bypass capacitors are recommended for each power supply line in any critical application. A 0.1µF ceramic and a 1µF electrolytic capacitor, as shown, placed as close as possible to the amplifier (with short lead lengths to power supply common) will assure adequate high frequency bypassing, in most applications.

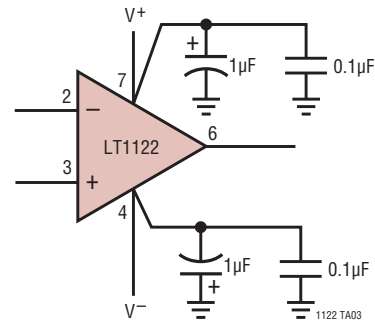

When the feedback around the op amp is resistive (R_F), a pole will be created with R_F , the source resistance and capacitance (R_S, C_S), and the amplifier input capacitance ($C_{IN} \approx 4pF$). In low closed-loop gain configurations and with R_S and R_F in the kilohm range, this pole can create excess phase shift and even oscillation. A small capacitor (C_F) in parallel with R_F eliminates this problem. With $R_S (C_S + C_{IN}) = R_F C_F$, the effect of the feedback pole is completely removed.

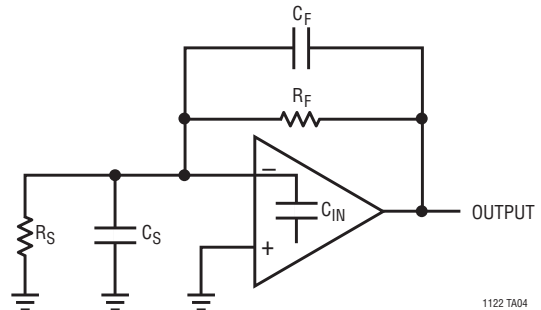

TYPICAL APPLICATIONS

Quartz Stabilized Oscillator With 9ppm Distortion

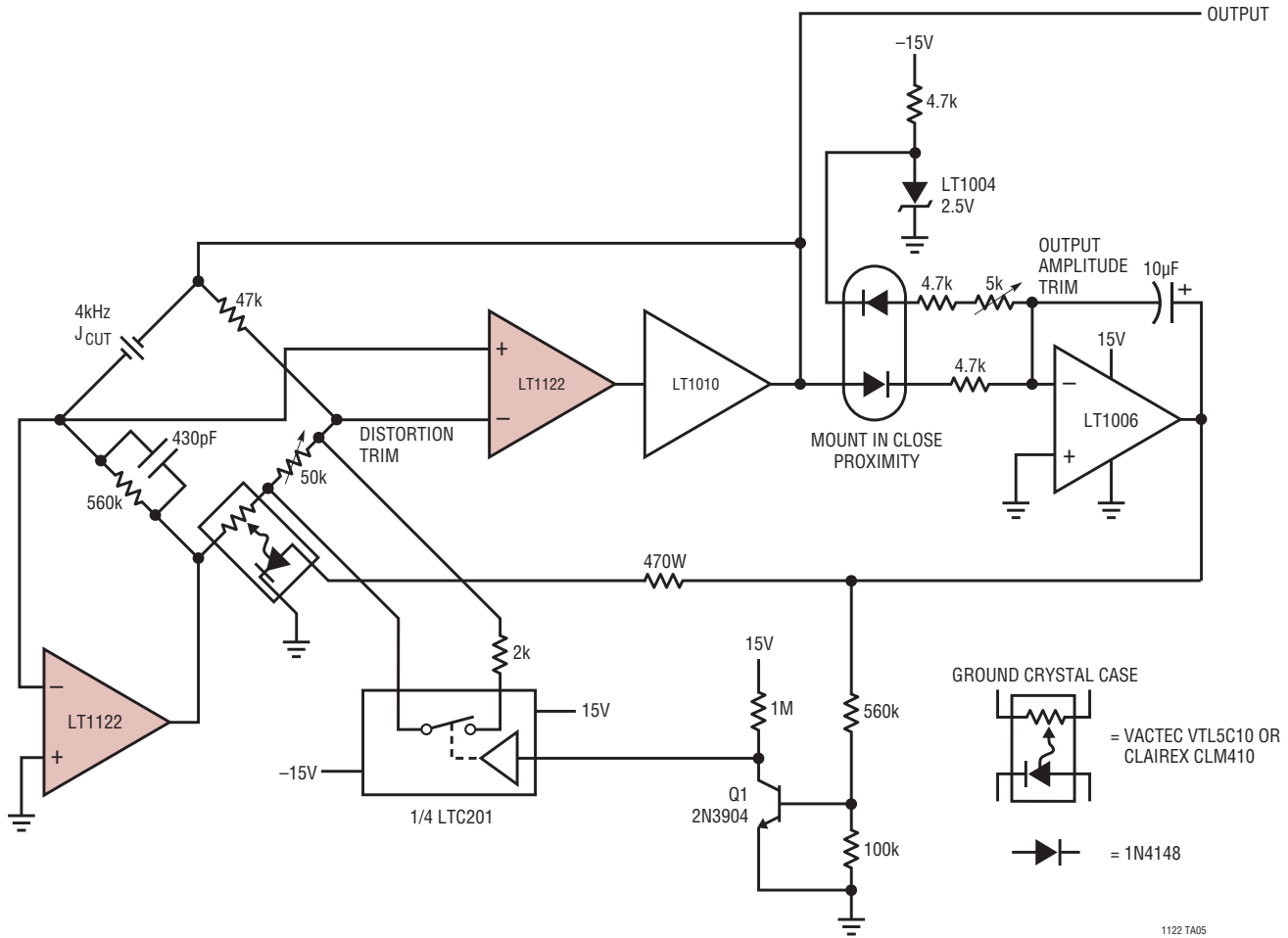

PACKAGE DESCRIPTION

Please refer to <http://www.linear.com/designtools/packaging/> for the most recent package drawings.

N Package
8-Lead PDIP (Narrow .300 Inch)
 (Reference LTC DWG # 05-08-1510 Rev I)

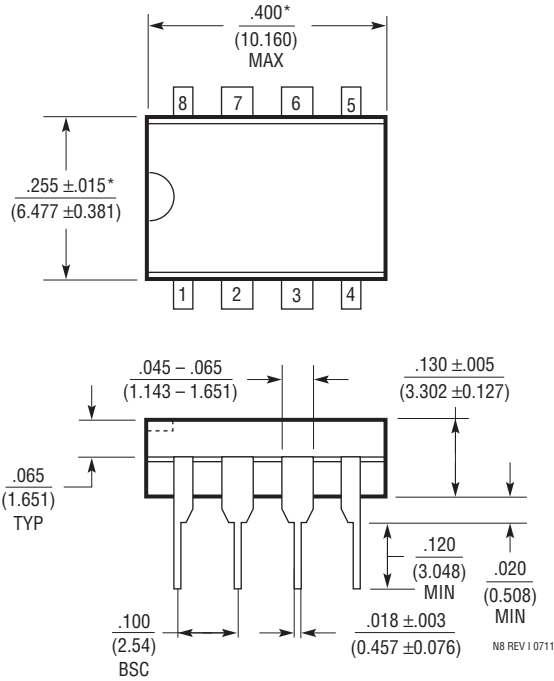

NOTE:
 1. DIMENSIONS ARE $\frac{\text{INCHES}}{\text{MILLIMETERS}}$
 *THESE DIMENSIONS DO NOT INCLUDE MOLD FLASH OR PROTRUSIONS.
 MOLD FLASH OR PROTRUSIONS SHALL NOT EXCEED .010 INCH (0.254mm)

PACKAGE DESCRIPTION

Please refer to <http://www.linear.com/designtools/packaging/> for the most recent package drawings.

J8 Package 3-Lead CERDIP (Narrow .300 Inch, Hermetic) (Reference LTC DWG # 05-08-1110)



NOTE: LEAD DIMENSIONS APPLY TO SOLDER DIP/PLATE OR TIN PLATE LEADS

J8 0801

OBSELETE PACKAGE

PACKAGE DESCRIPTION

Please refer to <http://www.linear.com/designtools/packaging/> for the most recent package drawings.

S8 Package 8-Lead Plastic Small Outline (Narrow .150 Inch) (Reference LTC DWG # 05-08-1610 Rev G)



RECOMMENDED SOLDER PAD LAYOUT

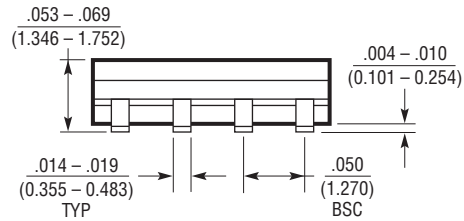
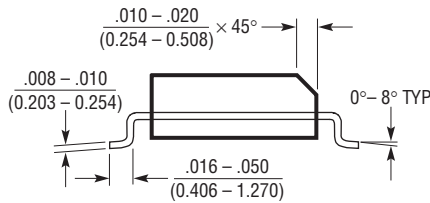
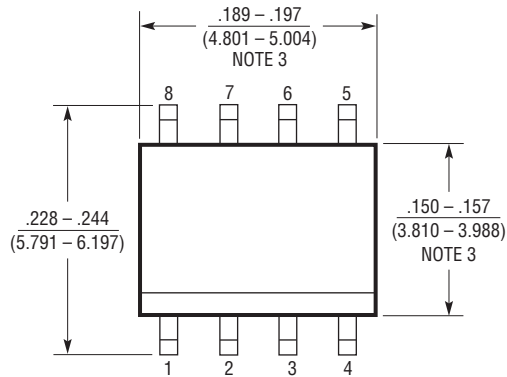

- NOTE:
 1. DIMENSIONS IN $\frac{\text{INCHES}}{\text{MILLIMETERS}}$
 2. DRAWING NOT TO SCALE
 3. THESE DIMENSIONS DO NOT INCLUDE MOLD FLASH OR PROTRUSIONS.
 MOLD FLASH OR PROTRUSIONS SHALL NOT EXCEED .006" (0.15mm)
 4. PIN 1 CAN BE BEVEL EDGE OR A DIMPLE

S08 REV G 0212

REVISION HISTORY (Revision history begins at Rev B)

REV	DATE	DESCRIPTION	PAGE NUMBER
B	02/14	Updated data sheet to current standards. New Order Information Table, Package Descriptions	2, 10-12

TYPICAL APPLICATION

Wide-Band, Filtered, Full Wave Rectifier

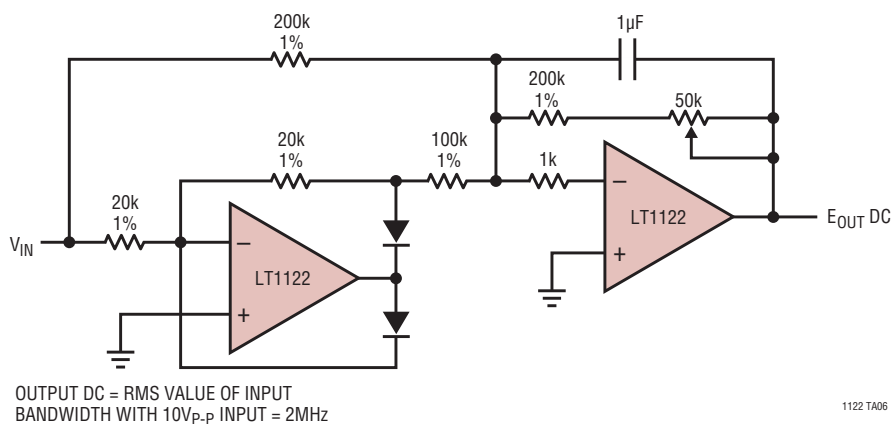

RELATED PARTS

PART NUMBER	DESCRIPTION	COMMENTS
LT1022	High Speed Precision JFET Op Amp	23V/µs Min Slew Rate, 250µV V _{OS}
LT1055/LT1056	Precision High Speed JFET Op Amps	16V/µs Slew Rate, 150µV V _{OS}
LT1464	1MHz C-Load™ Stable JFET Op Amp	Capacitive Loads Up to 10nF
LTC®6244	50MHz Low Noise CMOS Op Amp	1pA I _B , 100µV Max V _{OS} , 1.5µV _{p-p} , 0.1Hz to 10Hz Noise

Данный компонент на территории Российской Федерации

Вы можете приобрести в компании MosChip.

Для оперативного оформления запроса Вам необходимо перейти по данной ссылке:

<http://moschip.ru/get-element>

Вы можете разместить у нас заказ для любого Вашего проекта, будь то серийное производство или разработка единичного прибора.

В нашем ассортименте представлены ведущие мировые производители активных и пассивных электронных компонентов.

Нашей специализацией является поставка электронной компонентной базы двойного назначения, продукции таких производителей как XILINX, Intel (ex.ALTERA), Vicor, Microchip, Texas Instruments, Analog Devices, Mini-Circuits, Amphenol, Glenair.

Сотрудничество с глобальными дистрибьюторами электронных компонентов, предоставляет возможность заказывать и получать с международных складов практически любой перечень компонентов в оптимальные для Вас сроки.

На всех этапах разработки и производства наши партнеры могут получить квалифицированную поддержку опытных инженеров.

Система менеджмента качества компании отвечает требованиям в соответствии с ГОСТ Р ИСО 9001, ГОСТ РВ 0015-002 и ЭС РД 009

Офис по работе с юридическими лицами:

105318, г.Москва, ул.Щербаковская д.3, офис 1107, 1118, ДЦ «Щербаковский»

Телефон: +7 495 668-12-70 (многоканальный)

Факс: +7 495 668-12-70 (доб.304)

E-mail: info@moschip.ru

Skype отдела продаж:

moschip.ru

moschip.ru_4

moschip.ru_6

moschip.ru_9