

N57M5114

32-tap Digital Potentiometer (POT)

Description

The N57M5114 is a single digital POT designed as an electronic replacement for mechanical potentiometers and trim pots. Ideal for automated adjustments on high volume production lines, they are also well suited for applications where equipment requiring periodic adjustment is either difficult to access or located in a hazardous or remote environment.

The N57M5114 contains a 32-tap series resistor array connected between two terminals R_H and R_L . An up/down counter and decoder that are controlled by three input pins, determines which tap is connected to the wiper, R_W . The wiper setting, stored in nonvolatile memory, is not lost when the device is powered down and is automatically reinstated when power is returned. The wiper can be adjusted to test new system values without affecting the stored setting. Wiper-control of the N57M5114 is accomplished with three input control pins, \overline{CS} , U/\overline{D} , and \overline{INC} . The \overline{INC} input increments the wiper in the direction which is determined by the logic state of the U/\overline{D} input. The \overline{CS} input is used to select the device and also store the wiper position prior to power down.

The digital POT can be used as a three-terminal resistive divider or as a two-terminal variable resistor. Digital POTs bring variability and programmability to a wide variety of applications including control, parameter adjustments, and signal processing.

Features

- 32-position Linear Taper Potentiometer
- Non-volatile EEPROM Wiper Storage
- Low Standby Current
- Single Supply Operation: 2.5 V – 6.0 V
- Increment Up/Down Serial Interface
- Resistance Values: 10 k Ω , 50 k Ω and 100 k Ω
- Available in SOIC, TSSOP, MSOP and Space Saving 2 × 3 mm TDFN Packages
- These Devices are Pb-Free, Halogen Free/BFR Free and are RoHS Compliant

Applications

- Automated Product Calibration
- Remote Control Adjustments
- Offset, Gain and Zero Control
- Tamper-proof Calibrations
- Contrast, Brightness and Volume Controls
- Motor Controls and Feedback Systems
- Programmable Analog Functions



ON Semiconductor®

www.onsemi.com



SOIC-8
V SUFFIX
CASE 751BD



MSOP-8
Z SUFFIX
CASE 846AD



TSSOP-8
Y SUFFIX
CASE 948AL



TDFN-8
VP2 SUFFIX
CASE 511AK

PIN CONFIGURATIONS

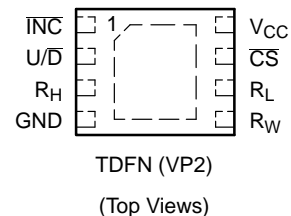
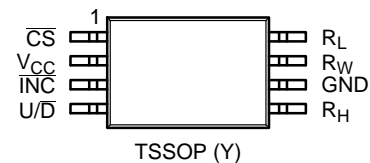
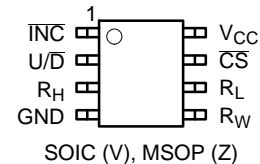

ORDERING INFORMATION

See detailed ordering and shipping information in the package dimensions section on page 9 of this data sheet.

N57M5114

DEVICE MARKING INFORMATION

SOIC

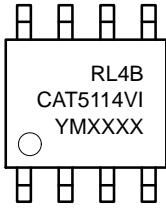

R = Resistance
 2 = 10 kΩ
 4 = 50 kΩ
 5 = 100 kΩ
 L = Assembly Location
 4 = Lead Finish – NiPdAu
 I = Industrial Temp Range
 Y = Production Year (Last Digit)
 M = Production Month (1–9, O, N, D)
 XXXX = Last Four Digits of Assembly Lot Number

MSOP

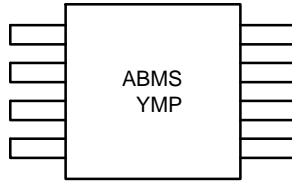

ABMS = 10 kΩ
 ABMT = 50 kΩ
 ABTH = 100 kΩ
 Y = Production Year (Last Digit)
 M = Production Month (1–9, O, N, D)
 P = Product Revision

TSSOP

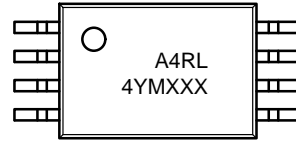

A4 = Device Code
 R = Resistance
 2 = 10 kΩ
 4 = 50 kΩ
 5 = 100 kΩ
 L = Assembly Location
 4 = Lead Finish – NiPdAu
 Y = Production Year (last digit)
 M = Production Month (1–9, O, N, D)
 XXX = Last Three Digits of Assembly Lot Number

TDFN



EF = 10 kΩ
 HF = 50 kΩ
 GW = 100 kΩ
 XXX = Last Three Digits of Assembly Lot Number
 Y = Production Year (Last Digit)
 M = Production Month (1–9, O, N, D)

Functional Diagram

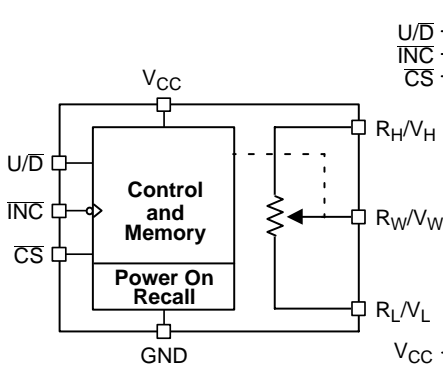

Figure 1. General

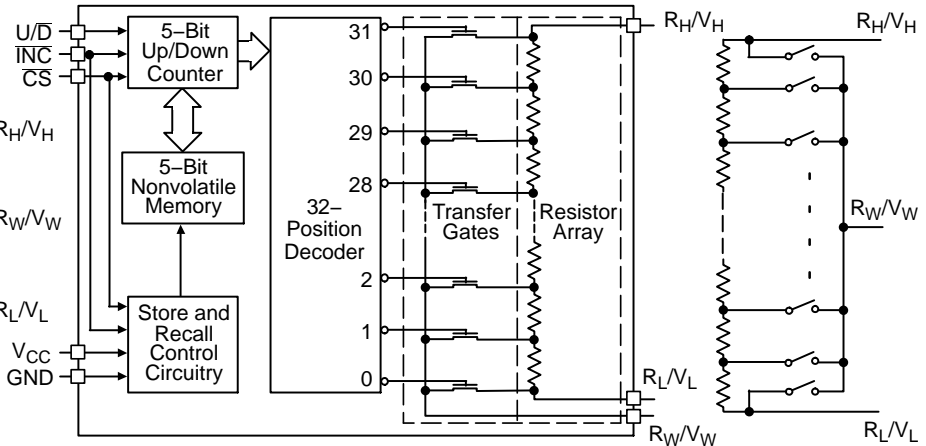

Figure 2. Detailed

Figure 3. Electronic Potentiometer Implementation

Table 1. PIN DESCRIPTIONS

Name	Function
$\overline{\text{INC}}$	Increment Control
$\text{U}/\overline{\text{D}}$	Up/Down Control
R_H	Potentiometer High Terminal
GND	Ground
R_W	Wiper Terminal
R_L	Potentiometer Low Terminal
$\overline{\text{CS}}$	Chip Select
V_{CC}	Supply Voltage

Pin Function

$\overline{\text{INC}}$: Increment Control Input

The $\overline{\text{INC}}$ input moves the wiper in the up or down direction determined by the condition of the $\text{U}/\overline{\text{D}}$ input.

$\text{U}/\overline{\text{D}}$: Up/Down Control Input

The $\text{U}/\overline{\text{D}}$ input controls the direction of the wiper movement. When in a high state and $\overline{\text{CS}}$ is low, any high-to-low transition on $\overline{\text{INC}}$ will cause the wiper to move one increment toward the R_H terminal. When in a low state and $\overline{\text{CS}}$ is low, any high-to-low transition on $\overline{\text{INC}}$ will cause the wiper to move one increment towards the R_L terminal.

R_H : High End Potentiometer Terminal

R_H is the high end terminal of the potentiometer. It is not required that this terminal be connected to a potential greater than the R_L terminal. Voltage applied to the R_H terminal cannot exceed the supply voltage, V_{CC} or go below ground, GND.

R_W : Wiper Potentiometer Terminal

R_W is the wiper terminal of the potentiometer. Its position on the resistor array is controlled by the control inputs, $\overline{\text{INC}}$, $\text{U}/\overline{\text{D}}$ and $\overline{\text{CS}}$. Voltage applied to the R_W terminal cannot exceed the supply voltage, V_{CC} or go below ground, GND.

R_L : Low End Potentiometer Terminal

R_L is the low end terminal of the potentiometer. It is not required that this terminal be connected to a potential less

than the R_H terminal. Voltage applied to the R_L terminal cannot exceed the supply voltage, V_{CC} or go below ground, GND. R_L and R_H are electrically interchangeable.

$\overline{\text{CS}}$: Chip Select

The chip select input is used to activate the control input of the N57M5114 and is active low. When in a high state, activity on the $\overline{\text{INC}}$ and $\text{U}/\overline{\text{D}}$ inputs will not affect or change the position of the wiper.

Device Operation

The N57M5114 operates like a digitally controlled potentiometer with R_H and R_L equivalent to the high and low terminals and R_W equivalent to the mechanical potentiometer's wiper. There are 32 available tap positions including the resistor end points, R_H and R_L . There are 31 resistor elements connected in series between the R_H and R_L terminals. The wiper terminal is connected to one of the 32 taps and controlled by three inputs, $\overline{\text{INC}}$, $\text{U}/\overline{\text{D}}$ and $\overline{\text{CS}}$. These inputs control a seven-bit up/down counter whose output is decoded to select the wiper position. The selected wiper position can be stored in nonvolatile memory using the $\overline{\text{INC}}$ and $\overline{\text{CS}}$ inputs.

With $\overline{\text{CS}}$ set LOW the N57M5114 is selected and will respond to the $\text{U}/\overline{\text{D}}$ and $\overline{\text{INC}}$ inputs. HIGH to LOW transitions on $\overline{\text{INC}}$ will increment or decrement the wiper (depending on the state of the $\text{U}/\overline{\text{D}}$ input and seven-bit counter). The wiper, when at either fixed terminal, acts like its mechanical equivalent and does not move beyond the last position. The value of the counter is stored in nonvolatile memory whenever $\overline{\text{CS}}$ transitions HIGH while the $\overline{\text{INC}}$ input is also HIGH. When the N57M5114 is powered-down, the last stored wiper counter position is maintained in the nonvolatile memory. When power is restored, the contents of the memory are recalled and the counter is set to the value stored.

With $\overline{\text{INC}}$ set low, the N57M5114 may be de-selected and powered down without storing the current wiper position in nonvolatile memory. This allows the system to always power up to a preset value stored in nonvolatile memory.

Table 2. OPERATION MODES

INC	CS	U/D	Operation
High to Low	Low	High	Wiper toward H
High to Low	Low	Low	Wiper toward L
High	Low to High	X	Store Wiper Position
Low	Low to High	X	No Store, Return to Standby
X	High	X	Standby

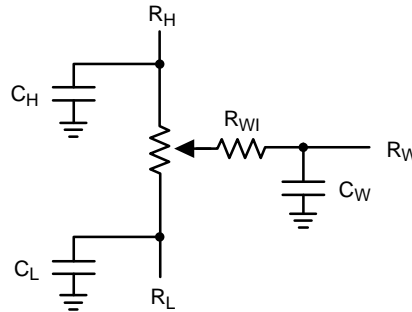

Figure 4. Potentiometer Equivalent Circuit

Table 3. ABSOLUTE MAXIMUM RATINGS

Parameters	Ratings	Units
Supply Voltage V _{CC} to GND	-0.5 to +7	V
Inputs CS to GND	-0.5 to V _{CC} +0.5	V
INC to GND	-0.5 to V _{CC} +0.5	V
U/D to GND	-0.5 to V _{CC} +0.5	V
H to GND	-0.5 to V _{CC} +0.5	V
L to GND	-0.5 to V _{CC} +0.5	V
W to GND	-0.5 to V _{CC} +0.5	V
Operating Ambient Temperature Industrial ('I' suffix)	-40 to +85	°C
Junction Temperature	+150	°C
Storage Temperature	-65 to 150	°C
Lead Soldering (10 s max)	+300	°C

Stresses exceeding those listed in the Maximum Ratings table may damage the device. If any of these limits are exceeded, device functionality should not be assumed, damage may occur and reliability may be affected.

Table 4. RELIABILITY CHARACTERISTICS

Symbol	Parameter	Test Method	Min	Typ	Max	Units
V _{ZAP} (Note 1)	ESD Susceptibility	MIL-STD-883, Test Method 3015	2000			V
I _{LTH} (Notes 1, 2)	Latch-up	JEDEC Standard 17	100			mA
T _{DR}	Data Retention	MIL-STD-883, Test Method 1008	100			Years
N _{END}	Endurance	MIL-STD-883, Test Method 1033	1,000,000			Stores

1. This parameter is tested initially and after a design or process change that affects the parameter.
2. Latch-up protection is provided for stresses up to 100 mA on address and data pins from -1 V to V_{CC} + 1 V.

N57M5114

Table 5. DC ELECTRICAL CHARACTERISTICS ($V_{CC} = +2.5\text{ V}$ to $+6\text{ V}$ unless otherwise specified)

Symbol	Parameter	Conditions	Min	Typ	Max	Units
POWER SUPPLY						
V_{CC}	Operating Voltage Range		2.5	–	6.0	V
I_{CC1}	Supply Current (Increment)	$V_{CC} = 6\text{ V}$, $f = 1\text{ MHz}$, $I_W = 0$	–	–	100	μA
		$V_{CC} = 6\text{ V}$, $f = 250\text{ kHz}$, $I_W = 0$	–	–	50	μA
I_{CC2}	Supply Current (Write)	Programming, $V_{CC} = 6\text{ V}$	–	–	1000	μA
		$V_{CC} = 3\text{ V}$	–	–	500	μA
I_{SB1} (Note 4)	Supply Current (Standby)	$\overline{CS} = V_{CC} - 0.3\text{ V}$ U/\overline{D} , $\overline{INC} = V_{CC} - 0.3\text{ V}$ or GND	–	–	1	μA
LOGIC INPUTS						
I_{IH}	Input Leakage Current	$V_{IN} = V_{CC}$	–	–	10	μA
I_{IL}	Input Leakage Current	$V_{IN} = 0\text{ V}$	–	–	–10	μA
V_{IH2}	CMOS High Level Input Voltage	$2.5\text{ V} \leq V_{CC} \leq 6\text{ V}$	$V_{CC} \times 0.7$	–	$V_{CC} + 0.3$	V
V_{IL2}	CMOS Low Level Input Voltage		–0.3	–	$V_{CC} \times 0.2$	V
POTENTIOMETER CHARACTERISTICS						
R_{POT}	Potentiometer Resistance	–10 Device		10		k Ω
		–50 Device		50		
		–00 Device		100		
	Pot. Resistance Tolerance				± 20	%
V_{RH}	Voltage on R_H pin		0		V_{CC}	V
V_{RL}	Voltage on R_L pin		0		V_{CC}	V
	Resolution			3.2		%
INL	Integral Linearity Error				0.5	LSB
DNL	Differential Linearity Error				0.25	LSB
R_{WI}	Wiper Resistance	$V_{CC} = 5\text{ V}$, $I_W = 1\text{ mA}$		70	200	Ω
		$V_{CC} = 2.5\text{ V}$, $I_W = 1\text{ mA}$		150	400	Ω
I_W	Wiper Current		–4.4		4.4	mA
TC_{RPOT}	TC of Pot Resistance			300		ppm/ $^{\circ}\text{C}$
TC_{RATIO}	Ratiometric TC				20	ppm/ $^{\circ}\text{C}$
V_N	Noise	100 kHz / 1 kHz		8/24		nV/ $\sqrt{\text{Hz}}$
$C_H/C_L/C_W$	Potentiometer Capacitances			8/8/25		pF
f_c	Frequency Response	Passive Attenuator, 10 k Ω		1.7		MHz

Product parametric performance is indicated in the Electrical Characteristics for the listed test conditions, unless otherwise noted. Product performance may not be indicated by the Electrical Characteristics if operated under different conditions.

3. This parameter is tested initially and after a design or process change that affects the parameter.
4. Latch-up protection is provided for stresses up to 100 mA on address and data pins from -1 V to $V_{CC} + 1\text{ V}$.
5. I_W = source or sink.
6. These parameters are periodically sampled and are not 100% tested.

Table 6. AC TEST CONDITIONS

V _{CC} Range	2.5 V ≤ V _{CC} ≤ 6 V
Input Pulse Levels	0.2 x V _{CC} to 0.7 x V _{CC}
Input Rise and Fall Times	10 ns
Input Reference Levels	0.5 x V _{CC}

Table 7. AC OPERATING CHARACTERISTICS (V_{CC} = +2.5 V to +6.0 V, V_H = V_{CC}, V_L = 0 V, unless otherwise specified)

Symbol	Parameter	Min	Typ (Note 7)	Max	Units
t _{CI}	\overline{CS} to \overline{INC} Setup	100	–	–	ns
t _{DI}	U/D to \overline{INC} Setup	50	–	–	ns
t _{ID}	U/D to \overline{INC} Hold	100	–	–	ns
t _{IL}	\overline{INC} LOW Period	250	–	–	ns
t _{IH}	\overline{INC} HIGH Period	250	–	–	ns
t _{IC}	\overline{INC} Inactive to \overline{CS} Inactive	1	–	–	μs
t _{CPH}	\overline{CS} Deselect Time (NO STORE)	100	–	–	ns
t _{CPH}	\overline{CS} Deselect Time (STORE)	10	–	–	ms
t _{IW}	\overline{INC} to V _{OUT} Change	–	1	5	μs
t _{CYC}	\overline{INC} Cycle Time	1	–	–	μs
t _R , t _F (Note 8)	\overline{INC} Input Rise and Fall Time	–	–	500	μs
t _{PU} (Note 8)	Power-up to Wiper Stable	–	–	1	ms
t _{WR}	Store Cycle	–	5	10	ms

7. Typical values are for T_A = 25°C and nominal supply voltage.

8. This parameter is periodically sampled and not 100% tested.

9. MI in the A.C. Timing diagram refers to the minimum incremental change in the W output due to a change in the wiper position.

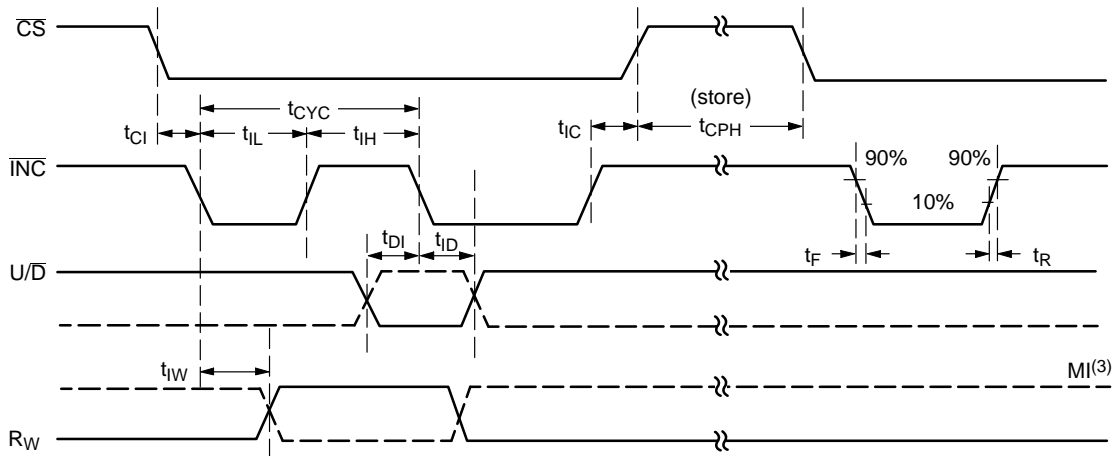

Figure 5. A.C. Timing

APPLICATIONS INFORMATION

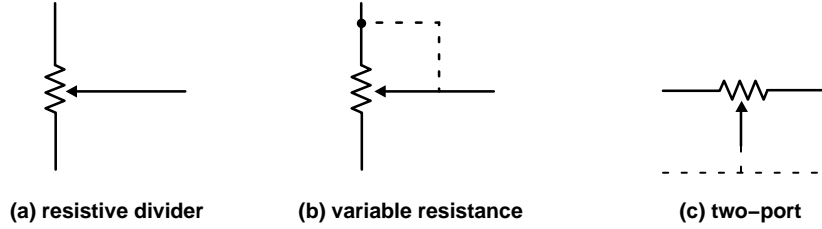

Figure 6. Potentiometer Configuration

Applications

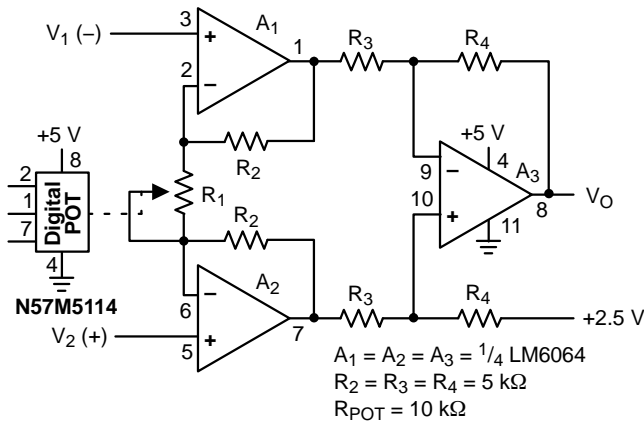

Figure 7. Programmable Instrumentation Amplifier

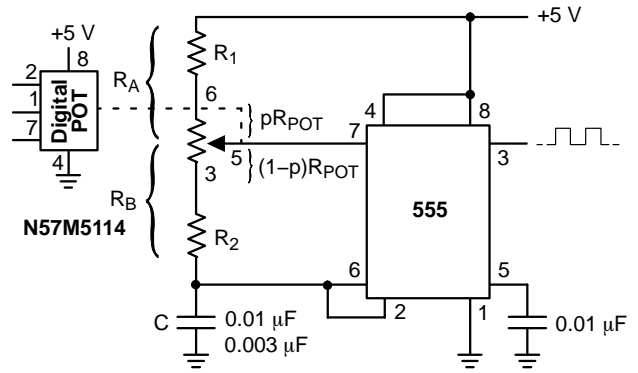

Figure 8. Programmable Sq. Wave Oscillator (555)

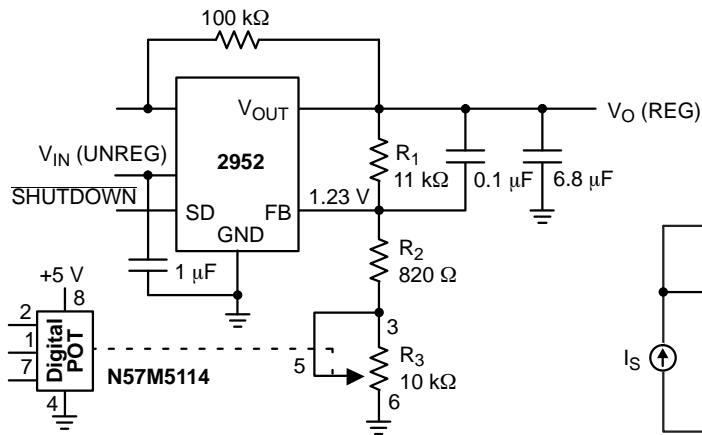

Figure 9. Programmable Voltage Regulator

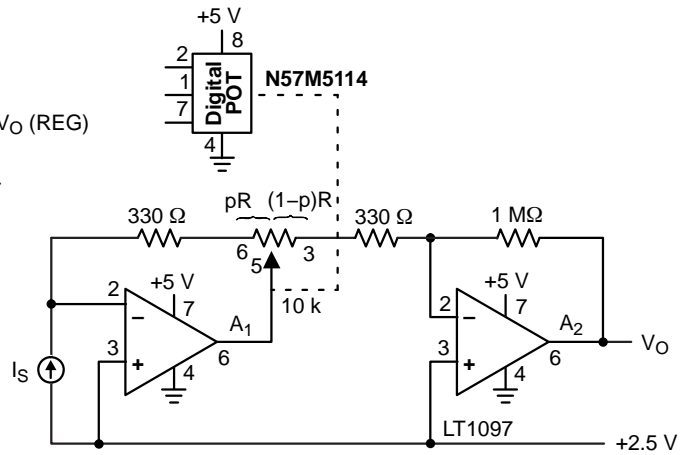

Figure 10. Programmable I to V Converter

N57M5114

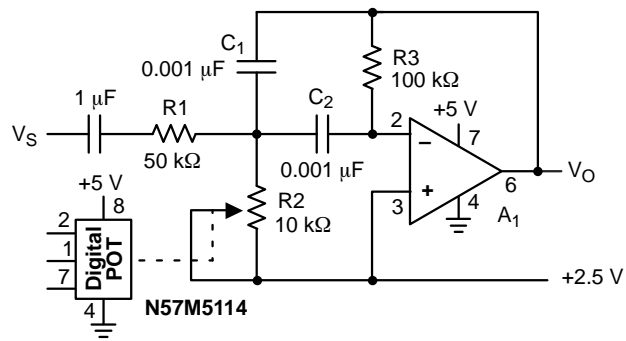

Figure 11. Programmable Bandpass Filter

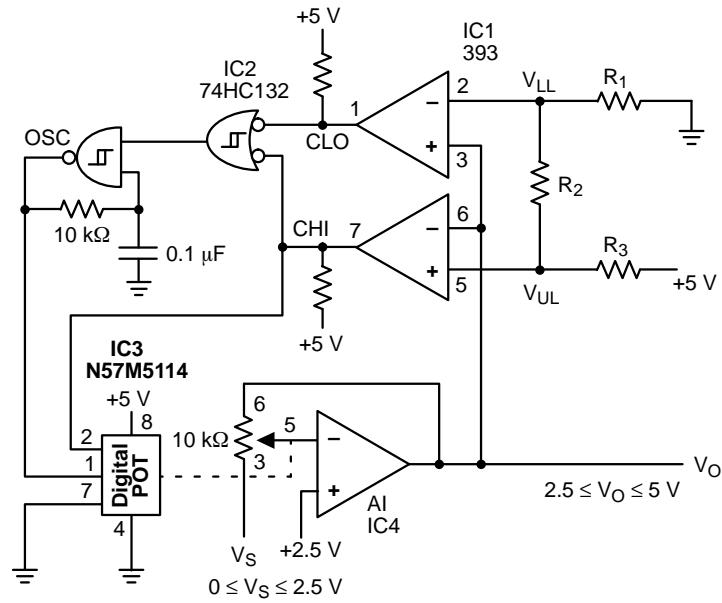

Figure 12. Automatic Gain Control

N57M5114

Table 8. ORDERING INFORMATION

Orderable Part Numbers	Resistance Values (kΩ)	Package-Pin	Lead Finish	Shipping†
N57M5114WD10TG	10	SOIC-8	NiPdAu	100 Units / Rail
N57M5114WD50TG	50			
N57M5114WD00TG	100			
N57M5114VP2D10TG	10	TDFN-8 2 x 3 mm	NiPdAu	3000 / Tape & Reel
N57M5114VP2D50TG	50			
N57M5114VP2D00TG	100			
N57M5114YD10TG	10	TSSOP-8	NiPdAu	3000 / Tape & Reel
N57M5114YD50TG	50			
N57M5114YD00TG	100			
N57M5114ZD10TG	10	MSOP-8	NiPdAu	96 Units / Rail
N57M5114ZD50TG	50			
N57M5114ZD00TG	100			

†For information on tape and reel specifications, including part orientation and tape sizes, please refer to our Tape and Reel Packaging Specifications Brochure, BRD8011/D.

10. All packages are RoHS-compliant (Pb-Free, Halogen-Free).

11. The standard lead finish is NiPdAu.

12. For additional package and temperature options, please contact your nearest ON Semiconductor Sales office.

N57M5114

PACKAGE DIMENSIONS

SOIC 8, 150 mils
CASE 751BD
ISSUE O

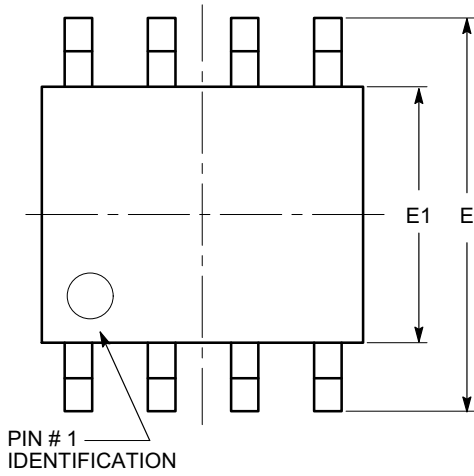

TOP VIEW

SYMBOL	MIN	NOM	MAX
A	1.35		1.75
A1	0.10		0.25
b	0.33		0.51
c	0.19		0.25
D	4.80		5.00
E	5.80		6.20
E1	3.80		4.00
e	1.27 BSC		
h	0.25		0.50
L	0.40		1.27
θ	0°		8°

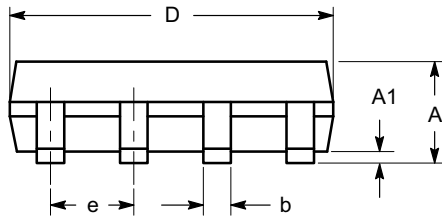

SIDE VIEW

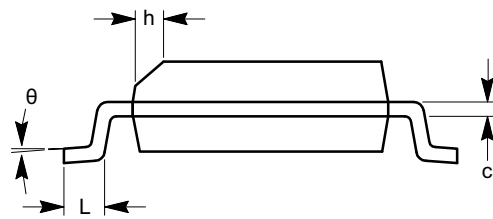

END VIEW

Notes:

- (1) All dimensions are in millimeters. Angles in degrees.
- (2) Complies with JEDEC MS-012.

N57M5114

PACKAGE DIMENSIONS

MSOP 8, 3x3
CASE 846AD
ISSUE O

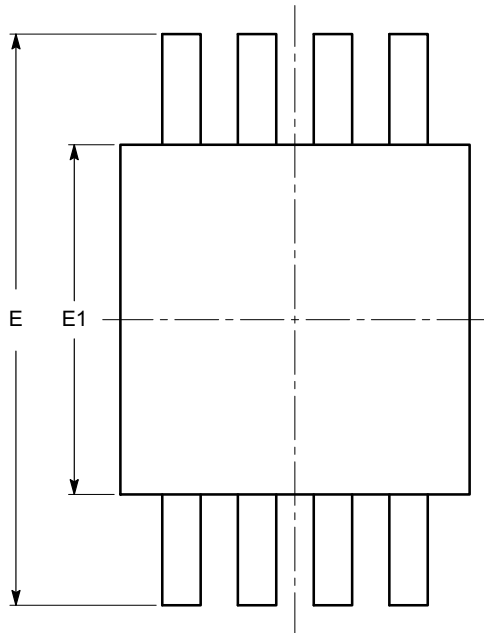

TOP VIEW

SYMBOL	MIN	NOM	MAX
A			1.10
A1	0.05	0.10	0.15
A2	0.75	0.85	0.95
b	0.22		0.38
c	0.13		0.23
D	2.90	3.00	3.10
E	4.80	4.90	5.00
E1	2.90	3.00	3.10
e	0.65 BSC		
L	0.40	0.60	0.80
L1	0.95 REF		
L2	0.25 BSC		
θ	0°		6°

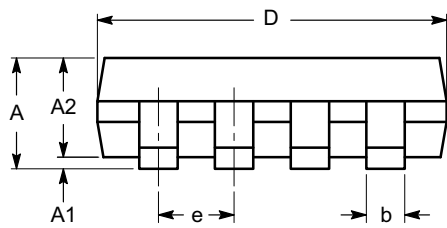

SIDE VIEW

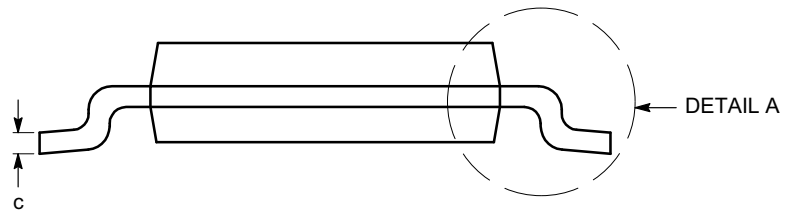

END VIEW

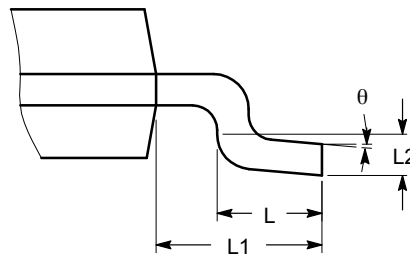

DETAIL A

Notes:

- (1) All dimensions are in millimeters. Angles in degrees.
- (2) Complies with JEDEC MO-187.

N57M5114

PACKAGE DIMENSIONS

TDFN8, 2x3
CASE 511AK
ISSUE A

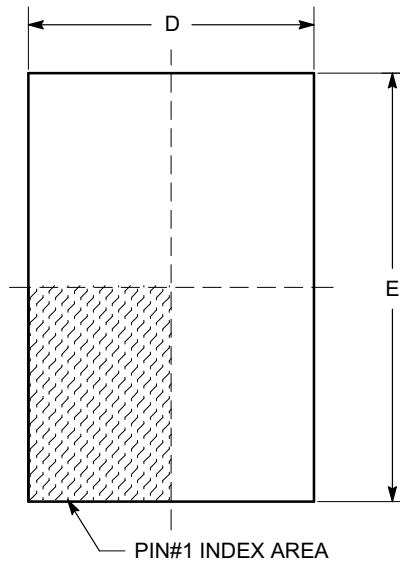

TOP VIEW

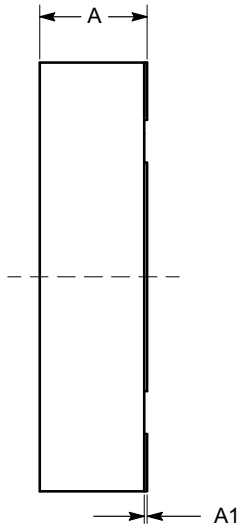

SIDE VIEW

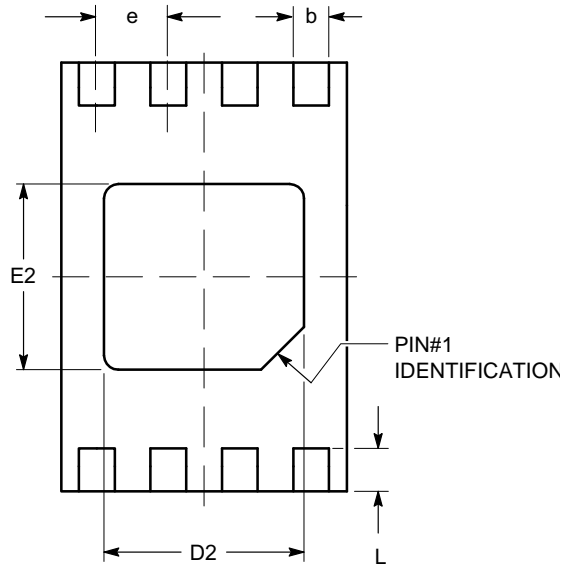

BOTTOM VIEW

SYMBOL	MIN	NOM	MAX
A	0.70	0.75	0.80
A1	0.00	0.02	0.05
A2	0.45	0.55	0.65
A3	0.20 REF		
b	0.20	0.25	0.30
D	1.90	2.00	2.10
D2	1.30	1.40	1.50
E	2.90	3.00	3.10
E2	1.20	1.30	1.40
e	0.50 TYP		
L	0.20	0.30	0.40

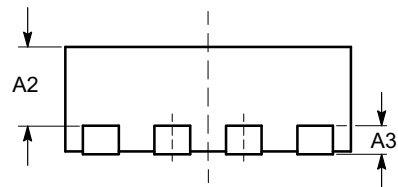

FRONT VIEW

Notes:

- (1) All dimensions are in millimeters.
- (2) Complies with JEDEC MO-229.

N57M5114

PACKAGE DIMENSIONS

TSSOP8, 4.4x3
CASE 948AL
ISSUE O

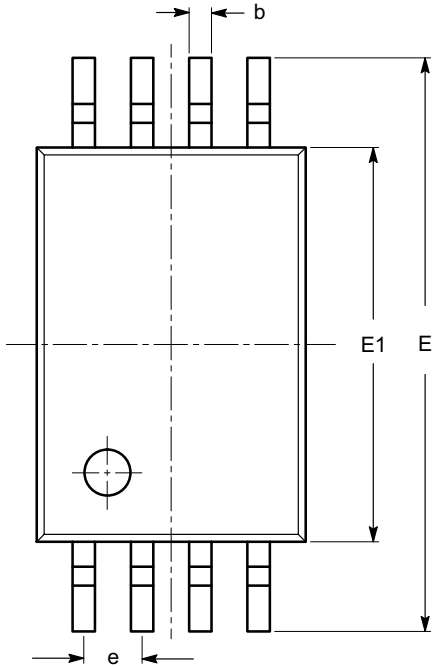

SYMBOL	MIN	NOM	MAX
A			1.20
A1	0.05		0.15
A2	0.80	0.90	1.05
b	0.19		0.30
c	0.09		0.20
D	2.90	3.00	3.10
E	6.30	6.40	6.50
E1	4.30	4.40	4.50
e	0.65 BSC		
L	1.00 REF		
L1	0.50	0.60	0.75
θ	0°		8°

TOP VIEW

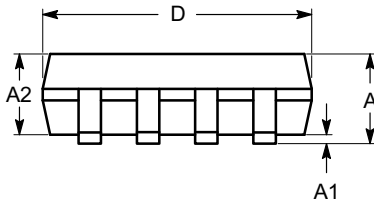

SIDE VIEW

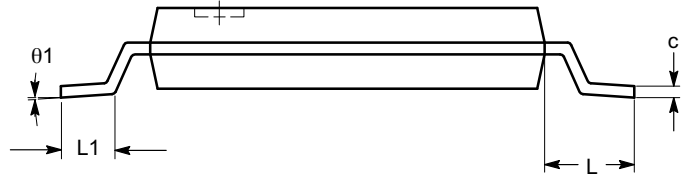

END VIEW

Notes:

- (1) All dimensions are in millimeters. Angles in degrees.
- (2) Complies with JEDEC MO-153.

ON Semiconductor and  are trademarks of Semiconductor Components Industries, LLC dba ON Semiconductor or its subsidiaries in the United States and/or other countries. ON Semiconductor owns the rights to a number of patents, trademarks, copyrights, trade secrets, and other intellectual property. A listing of ON Semiconductor's product/patent coverage may be accessed at www.onsemi.com/site/pdf/Patent-Marking.pdf. ON Semiconductor reserves the right to make changes without further notice to any products herein. ON Semiconductor makes no warranty, representation or guarantee regarding the suitability of its products for any particular purpose, nor does ON Semiconductor assume any liability arising out of the application or use of any product or circuit, and specifically disclaims any and all liability, including without limitation special, consequential or incidental damages. Buyer is responsible for its products and applications using ON Semiconductor products, including compliance with all laws, regulations and safety requirements or standards, regardless of any support or applications information provided by ON Semiconductor. "Typical" parameters which may be provided in ON Semiconductor data sheets and/or specifications can and do vary in different applications and actual performance may vary over time. All operating parameters, including "Typicals" must be validated for each customer application by customer's technical experts. ON Semiconductor does not convey any license under its patent rights nor the rights of others. ON Semiconductor products are not designed, intended, or authorized for use as a critical component in life support systems or any FDA Class 3 medical devices or medical devices with a same or similar classification in a foreign jurisdiction or any devices intended for implantation in the human body. Should Buyer purchase or use ON Semiconductor products for any such unintended or unauthorized application, Buyer shall indemnify and hold ON Semiconductor and its officers, employees, subsidiaries, affiliates, and distributors harmless against all claims, costs, damages, and expenses, and reasonable attorney fees arising out of, directly or indirectly, any claim of personal injury or death associated with such unintended or unauthorized use, even if such claim alleges that ON Semiconductor was negligent regarding the design or manufacture of the part. ON Semiconductor is an Equal Opportunity/Affirmative Action Employer. This literature is subject to all applicable copyright laws and is not for resale in any manner.

PUBLICATION ORDERING INFORMATION

LITERATURE FULFILLMENT:

Literature Distribution Center for ON Semiconductor
19521 E. 32nd Pkwy, Aurora, Colorado 80011 USA
Phone: 303-675-2175 or 800-344-3860 Toll Free USA/Canada
Fax: 303-675-2176 or 800-344-3867 Toll Free USA/Canada
Email: orderlit@onsemi.com

N. American Technical Support: 800-282-9855 Toll Free
USA/Canada
Europe, Middle East and Africa Technical Support:
Phone: 421 33 790 2910

ON Semiconductor Website: www.onsemi.com

Order Literature: <http://www.onsemi.com/orderlit>

For additional information, please contact your local Sales Representative

Данный компонент на территории Российской Федерации

Вы можете приобрести в компании MosChip.

Для оперативного оформления запроса Вам необходимо перейти по данной ссылке:

<http://moschip.ru/get-element>

Вы можете разместить у нас заказ для любого Вашего проекта, будь то серийное производство или разработка единичного прибора.

В нашем ассортименте представлены ведущие мировые производители активных и пассивных электронных компонентов.

Нашей специализацией является поставка электронной компонентной базы двойного назначения, продукции таких производителей как XILINX, Intel (ex.ALTERA), Vicor, Microchip, Texas Instruments, Analog Devices, Mini-Circuits, Amphenol, Glenair.

Сотрудничество с глобальными дистрибьюторами электронных компонентов, предоставляет возможность заказывать и получать с международных складов практически любой перечень компонентов в оптимальные для Вас сроки.

На всех этапах разработки и производства наши партнеры могут получить квалифицированную поддержку опытных инженеров.

Система менеджмента качества компании отвечает требованиям в соответствии с ГОСТ Р ИСО 9001, ГОСТ РВ 0015-002 и ЭС РД 009

Офис по работе с юридическими лицами:

105318, г.Москва, ул.Щербаковская д.3, офис 1107, 1118, ДЦ «Щербаковский»

Телефон: +7 495 668-12-70 (многоканальный)

Факс: +7 495 668-12-70 (доб.304)

E-mail: info@moschip.ru

Skype отдела продаж:

moschip.ru

moschip.ru_4

moschip.ru_6

moschip.ru_9