

# Single-phase DC Brushless Motor Driver IC

## ■ GENERAL DESCRIPTION

The NJU7356 is a single-phase DC brushless motor driver IC designed for small and high power fan-motor applications.

It provides a low operating current of 2mA (typ.) and low saturation output voltage at high output current operation, which offers a high efficiency motor driving. It also has a high output current capability of 1000mA (peak) and 400mA (continuous).

The NJU7356 has useful functions such as a FG (frequency generator) output useful for various control systems, lock detect, auto-release (c-less type), thermal shutdown and linear driving which offers low noise motor driving. The NJU7356 is available in a small and thin package of MSOP8 (TVSP8), which provides downsizing and thinning in motor applications.

## ■ PACKAGE OUTLINE



**NJU7356RB1**  
( MSOP8 (TVSP8) )

## ■ FEATURES

- Operating Voltage                    2.2 to 5.5V
- Low Operating Current             $I_{DD}=2mA$
- Low Saturation Output Voltage  
    $V_{sat}= \pm 0.2V @ I_o=\pm 400mA$
- Lock Detect / Auto Release Circuit
- Thermal Shutdown Circuit
- Frequency Generator Output
- Hall Bias Terminal
- CMOS Technology
- Package Outline                    MSOP8 (TVSP8)\*  
   \*MEET JEDEC MO-187-DA/ THIN TYPE

## ■ BLOCK DIAGRAM

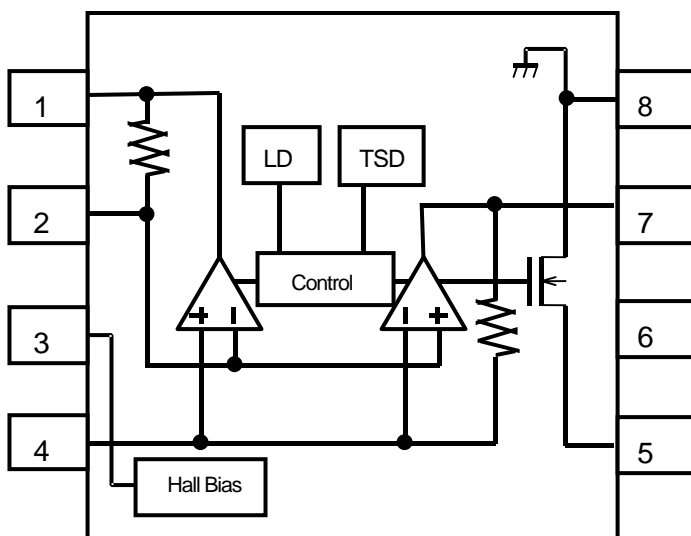

## ■ PIN FUNCTION

- 1: OUT B
- 2: IN +
- 3: HB
- 4: IN -
- 5: FG
- 6: V<sub>DD</sub>
- 7: OUT A
- 8: V<sub>SS</sub>

# NJU7356

## ■ ABSOLUTE MAXIMUM RATINGS

(Ta=25°C)

PARAMETER	RATINGS	SYMBOL (unit)	NOTE
Supply Voltage	+7.0	V <sub>DD</sub> (V)	
Input Voltage	-0.3 to V <sub>DD</sub>	V <sub>ID</sub> (V)	
Output Current (Continuance)	400	I <sub>O</sub> (mA)	Note1
Output Current (Peak)	1000	I <sub>O PEAK</sub> (mA)	Note2
Operating Temperature Range	-40 to +85	T <sub>opr</sub> (°C)	
Storage Temperature Range	-50 to +150	T <sub>stg</sub> (°C)	
Power Dissipation	400	P <sub>D</sub> (mW)	Device itself
Junction Temperature	150	T <sub>jmax</sub> (°C)	

Note1 : This value is not to be over Pd.

Note2 : Input voltage is not to be over supply voltage to really use.

## ■ RECOMMENDED OPERATING CONDITIONS

(Ta=25°C)

PARAMETER	SYMBOL	CONDITION	MIN.	TYP.	MAX.	UNIT
Supply Voltage	V <sub>DD</sub>	Ct=0	2.2	5.0	5.5	V

## ■ ELECTRICAL CHARACTERISTICS

(V<sub>DD</sub> =5V, T<sub>a</sub>=25°C)

PARAMETER	SYMBOL	CONDITION	MIN.	TYP.	MAX.	UNIT
<b>General</b>						
Operating Current	I <sub>DD</sub>	-	-	2.0	5.0	mA
Thermal Shutdown Temperature	T <sub>TSD</sub>	-	-	180	-	°C
Thermal Shutdown Hysteresis	T <sub>HYS</sub>	-	-	50	-	°C
<b>Hall Amplifier</b>						
Input Offset Voltage	V <sub>IO</sub>	-	-10	-	10	mV
Feedback Resistance	R <sub>F</sub>	-	-	27.5	-	kΩ
Open Loop Gain	A <sub>V</sub>	-	-	70	-	dB
Input Common Mode Voltage Range	V <sub>ICM</sub>	-	0.4	-	4.0	V
<b>Output</b>						
Maximum Output Voltage Range	V <sub>OH</sub>	I <sub>o</sub> =+400mA	4.65	4.80	-	V
	V <sub>OL</sub>	I <sub>o</sub> =-400mA	-	0.20	0.35	
Output Resistance	R <sub>ONH</sub>	I <sub>o</sub> =+400mA	-	0.5	-	Ω
	R <sub>ONL</sub>	I <sub>o</sub> =-400mA	-	0.5	-	
FG L Output Voltage	V <sub>FG</sub>	I <sub>N+</sub> =5V, I <sub>N-</sub> =0V, R <sub>L</sub> =10kΩ	-	-	0.3	V
FG H Leak Current	I <sub>FG-LEAK</sub>	I <sub>N+</sub> =0V, I <sub>N-</sub> =5V, FG=5V	-	-	1.0	μA
<b>Lock Detect Circuit*</b>						
Lock Protect ON Time	T <sub>ON</sub>	-	-	0.5	-	sec
Lock Protect OFF Time	T <sub>OFF</sub>	-	-	3.5	-	sec
Detect Protection ON/OFF Ratio	T <sub>RATIO</sub>	-	-	1:7	-	-
<b>Hall Bias</b>						
Hall Bias Voltage	V <sub>HB</sub>	-	1.1	1.3	1.5	V

# NJU7356

## INPUT-OUTPUT TRUTH TABLE

IN+	IN -	OUTA	OUTB	FG
H	L	H	L	L (Output Transistor ON)
L	H	L	H	Z (Output Transistor OFF)

## TIMING CHART

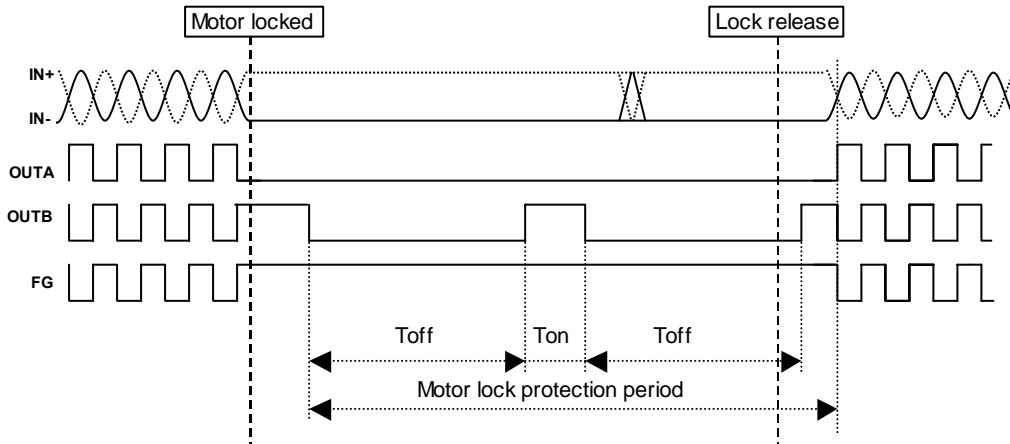

## POWER DISSIPATION

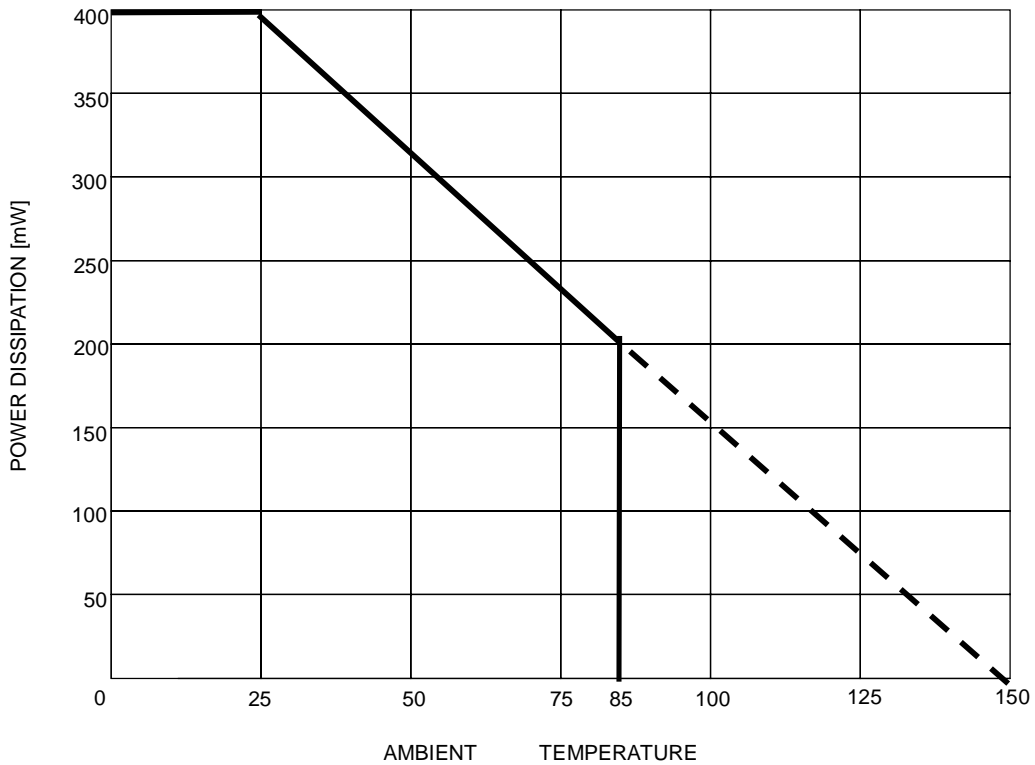

## TYPICAL CHARACTERISTICS

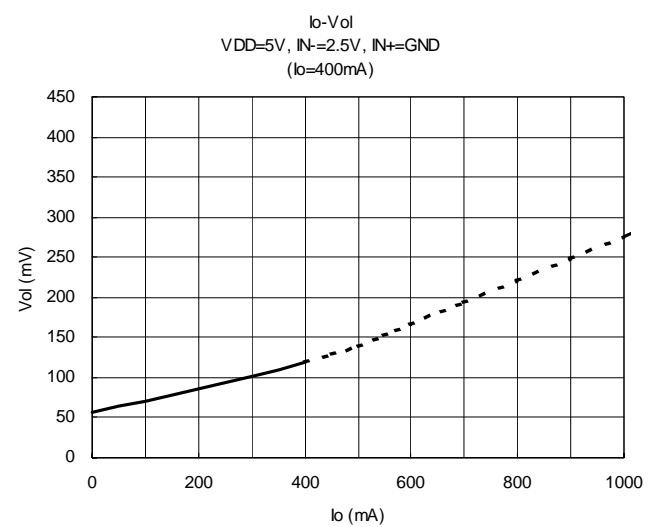
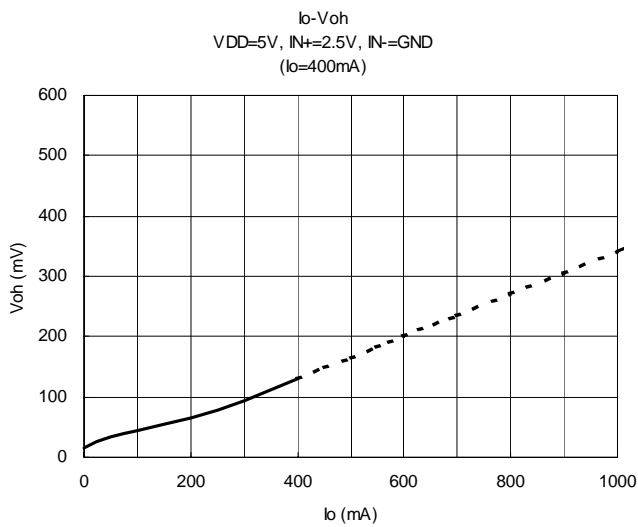
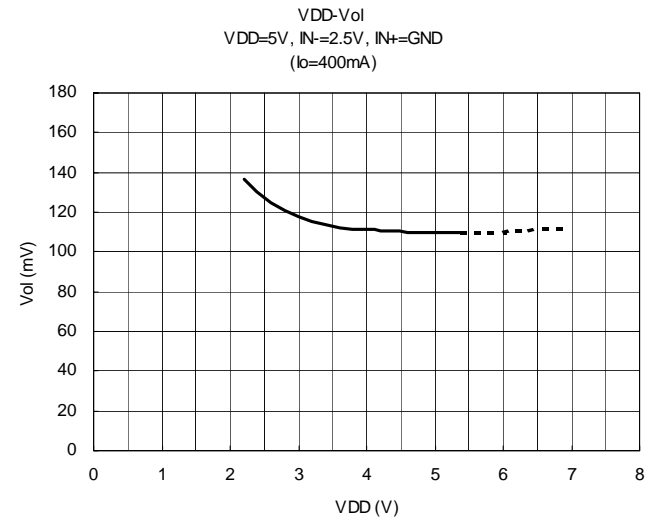
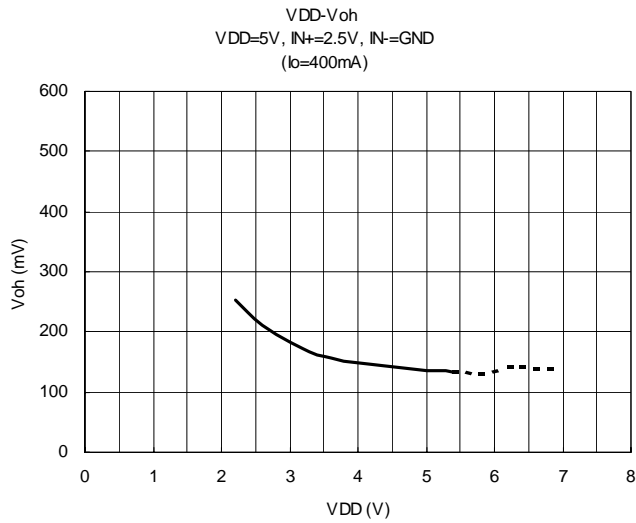
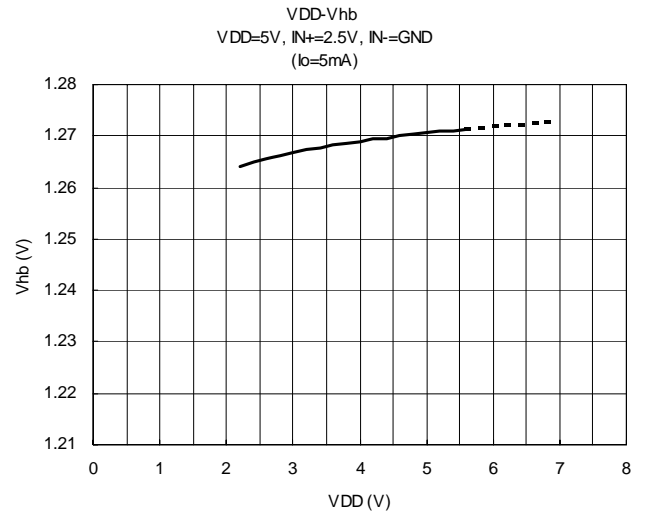
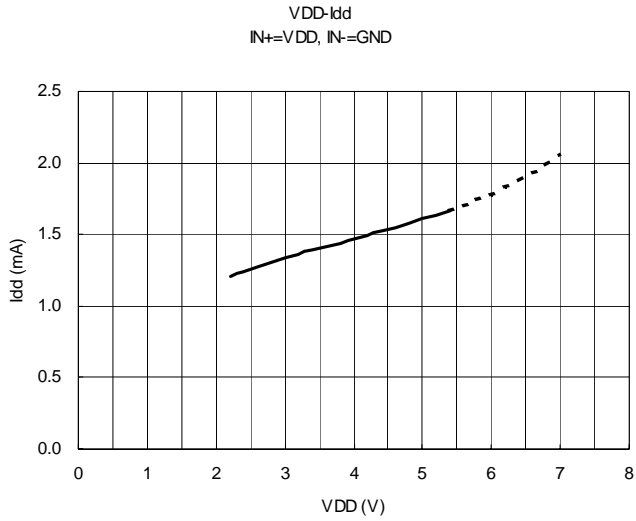

## ■ TYPICAL CHARACTERISTICS

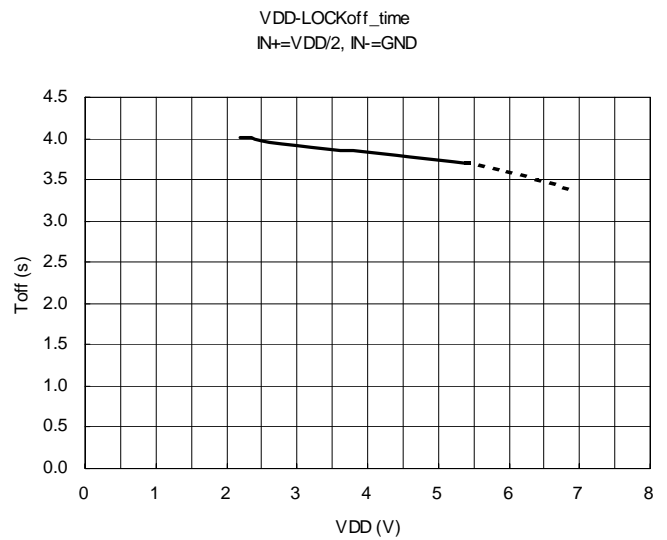
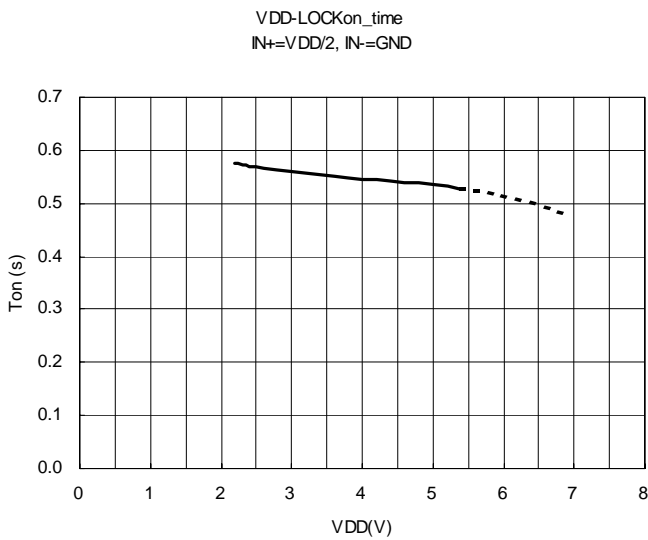

## APPLICATION NOTE

The NJU7356 is a single-phase DC brushless motor driver IC in small MSOP8 (TVSP8) package. With minimal external components, that can drive up to 400mA of motor current for small fan application.

[Application Circuit Example]

### 1) Hall Bias unused application circuit

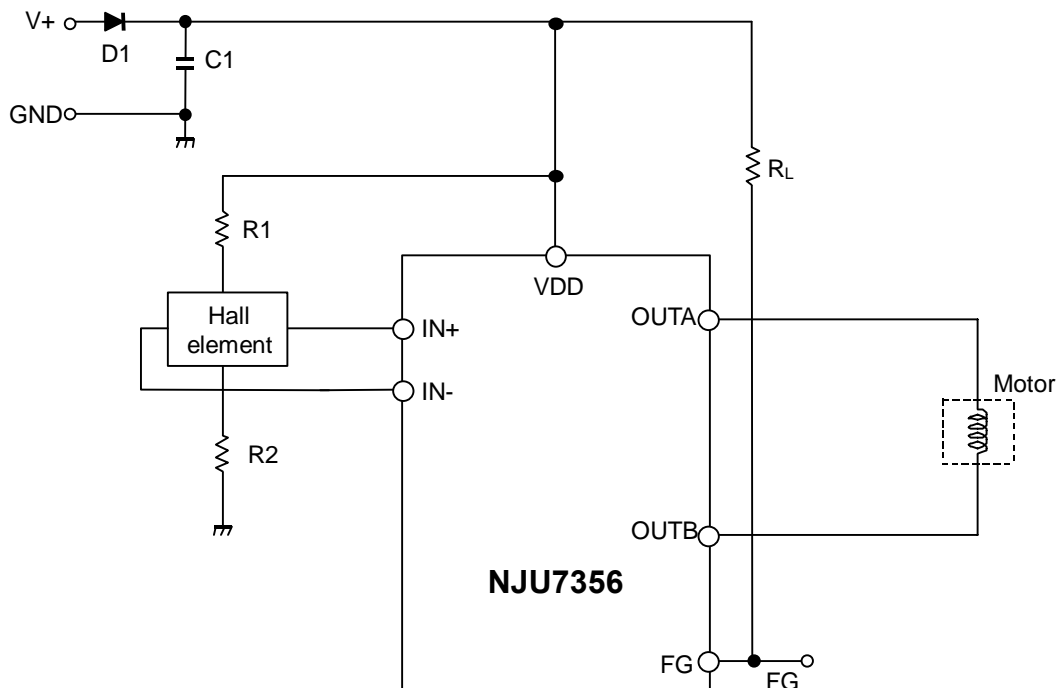

### 2) Hall bias used application circuit

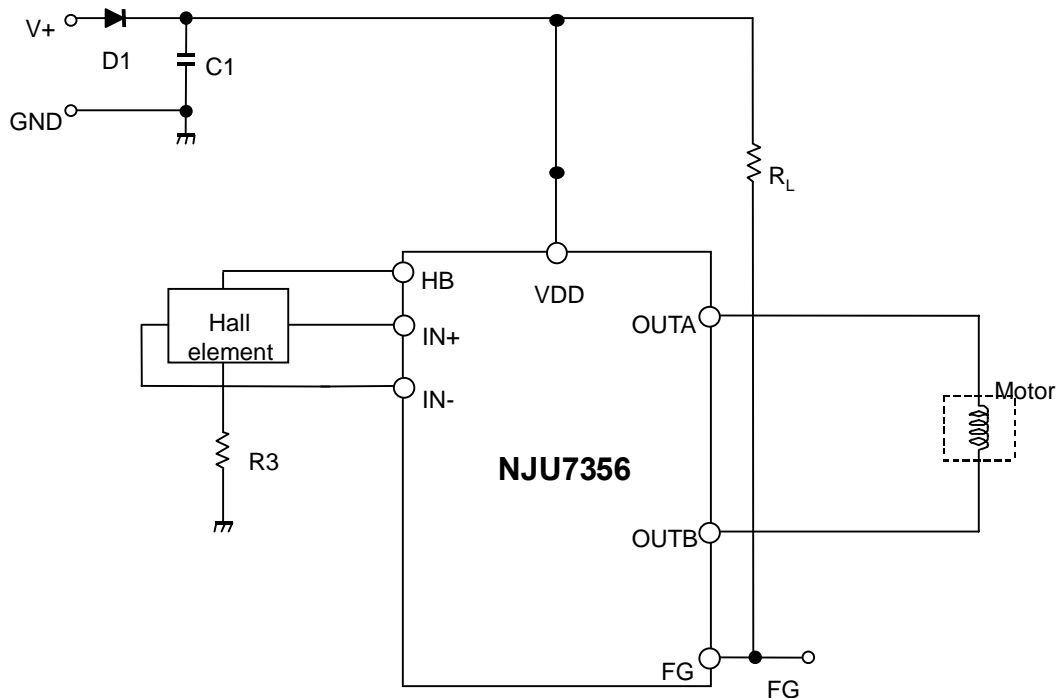

## [Design Notes]

Above application example is designed for 5V operation with motor current of 400mA. It uses the following components:

Hall elements: HW101A (AKE)

### 1. Selection of C1 and D1:

C1 is used for a noise reduction purpose. A typical value is 0.1uF.

Optimize the value in actual operating conditions if necessary. D1 is a diode for protection against reverse voltage supply. Silicon rectifier diode (WO3C, 10D1 and equivalent) is appropriate.

### 2. Position Detection Circuit Hall Device

#### 2-1. When using $V_{DD}$ (**R1 and R2**)

Hall amplifier is a differential amplifier.

The common-mode input voltage is between 0.4V and  $V_{DD}-1V$  and the input signal must be within the range.

Non-excitation hall bias voltage is to be set at a half of  $V_{DD}$  for effective use of common-mode input voltage range.

Therefore the same value of hall bias resistors is selected for R1 and R2.

Given that the bias current is set to be 5mA by HW101A datasheet, R1 and R2 can be determined as follows:

$$R1 + R2 + R_{in} = \frac{V_{DD}}{I_{bias}} = \frac{5}{5 \times 10^{-3}} = 1.0k\Omega$$

$$R1 = R2 = 300\Omega$$

The output voltage of hall elements is influenced by the bias current and magnetic flux density of hall elements.

The optimum input voltage of NJU7356 is 100mVp-p and higher. With such input voltage, the highest efficiency can be obtained.

## 2-2. When using HB (R3 design)

By connecting a Hall device to the Hall bias terminal (HB), a constant Hall output amplitude that has good temperature characteristics is obtained, resulting in stable linear drive. If it is necessary to adjust the Hall output amplitude, perform adjustment with R3.

## 3. Design of FG output resistance ( $R_L$ )

FG Out (FG: Pin5) is an open drain output and  $R_L$  is a pull up register. A typical value of  $R_L$  is 10k $\Omega$ .

The timing chart of FG Out is as follows.

Note that the pull up resistance shall be connected to below supply voltage.

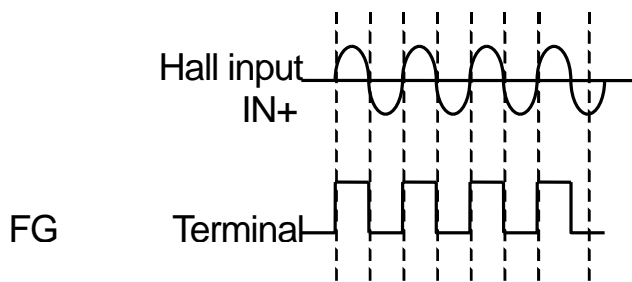

The specifications on this data book are only given for information, without any guarantee as regards either mistakes or omissions. The application circuit in this data book are described only to show representative usages of the product and not intended for the guarantee or permission of any right including the industrial rights.



# Mouser Electronics

Authorized Distributor

Click to View Pricing, Inventory, Delivery & Lifecycle Information:

[NJR:](#)

[NJU7356RB1-TE1](#)

## Данный компонент на территории Российской Федерации

### Вы можете приобрести в компании MosChip.

Для оперативного оформления запроса Вам необходимо перейти по данной ссылке:

<http://moschip.ru/get-element>

Вы можете разместить у нас заказ для любого Вашего проекта, будь то серийное производство или разработка единичного прибора.

В нашем ассортименте представлены ведущие мировые производители активных и пассивных электронных компонентов.

Нашей специализацией является поставка электронной компонентной базы двойного назначения, продукции таких производителей как XILINX, Intel (ex.ALTERA), Vicor, Microchip, Texas Instruments, Analog Devices, Mini-Circuits, Amphenol, Glenair.

Сотрудничество с глобальными дистрибьюторами электронных компонентов, предоставляет возможность заказывать и получать с международных складов практически любой перечень компонентов в оптимальные для Вас сроки.

На всех этапах разработки и производства наши партнеры могут получить квалифицированную поддержку опытных инженеров.

Система менеджмента качества компании отвечает требованиям в соответствии с ГОСТ Р ИСО 9001, ГОСТ РВ 0015-002 и ЭС РД 009

### Офис по работе с юридическими лицами:

105318, г.Москва, ул.Щербаковская д.3, офис 1107, 1118, ДЦ «Щербаковский»

Телефон: +7 495 668-12-70 (многоканальный)

Факс: +7 495 668-12-70 (доб.304)

E-mail: [info@moschip.ru](mailto:info@moschip.ru)

Skype отдела продаж:

moschip.ru

moschip.ru\_4

moschip.ru\_6

moschip.ru\_9