

## DESCRIPTION

Demonstration circuit 858 is a Triple High-Speed 2:1 Video MUX featuring the LT6555. This Demo Circuit provides DC-coupled 75Ω inputs/outputs and is intended to operate from split power supplies. The ultra high bandwidth and channel-switching rate make the LT6555 ideal for HDTV and UXGA video equipment.

The Performance Summary table below indicates the operating characteristics of this demonstration circuit.

**Design files for this circuit board are available. Call the LTC factory.**

 , LTC and LT are registered trademarks of Linear Technology Corporation. ThinSOT and PowerPath are trademarks of Linear Technology Corporation.

## PERFORMANCE SUMMARY

Specifications are at T<sub>A</sub> = 25°C

SYMBOL	PARAMETER	CONDITIONS	MIN	TYP	MAX	UNITS
V <sub>CC</sub> V <sub>EE</sub>	Supply Voltage(s)	Split supply operation	±3.3	±5.0	±5.5	V
		Single supply operation	6		12	V
Z <sub>IN</sub>	Input Impedance, IN1A, IN2A, IN3A, IN1B, IN2B, IN3B	DC-coupled		75		Ω
Z <sub>OUT</sub>	Output Impedance, OUT1, OUT2, OUT3	DC-coupled		75		Ω
A	Gain	Outputs terminated into 75Ω		0.0		dB
		Outputs terminated into High impedance		6.0		dB
BW	Bandwidth	-3dB, Small Signal		650		MHz
	Crosstalk	Worst-case All Hostile, 10MHz		-75		dB
		Worst-case All Hostile, 100MHz		-50		dB
V <sub>IN</sub>	Input Signal Voltage Range (note: feedback resistor connections tied to ground on printed circuit)	±3.3V Split Supply, No Output Clipping	±0.7			V
		±5.0V Split Supply, No Output Clipping	±1.5			V
		+9.0V Single Supply, V <sub>REF</sub> = 2.2V No Output Clipping	+1.0		+3.5	V
V <sub>EN</sub> , V <sub>SEL</sub>	Control Input Voltage	Logic Low Voltage (Amplifiers ON, Inputs A active), DGND = 0V	-0.3		1.0	V
		Logic High Voltage (Amplifiers OFF, Inputs B active), DGND = 0V	1.8	(EN)	5.5	V
			1.8	(SEL)	8	V
t <sub>SEL</sub>	Select Response Time			8		ns
t <sub>EN</sub>	Enable/Disable Response Time			50/500		ns
I <sub>CC</sub> , I <sub>EE</sub>	Supply Current	±5.0V supply, No signal		27		mA

and/or video analyzer to the outputs, using equal-length cabling amongst the three video channels. Figure 2 shows a typical pulse response.

- To evaluate the shutdown mode, disconnect or relocate the JP1 jumper to the EXT position (with no connections made at EN (J1 or E1), or if present, a logic high provided).

- To evaluate the input selection feature, place the JP4 jumper in either the A or B position to activate the appropriate input. If JP4 is in the B position, a select command signal may be furnished to SEL A/B (J8 or E4) from an external source. Logic low selects input-group A and logic high selects input-group B.

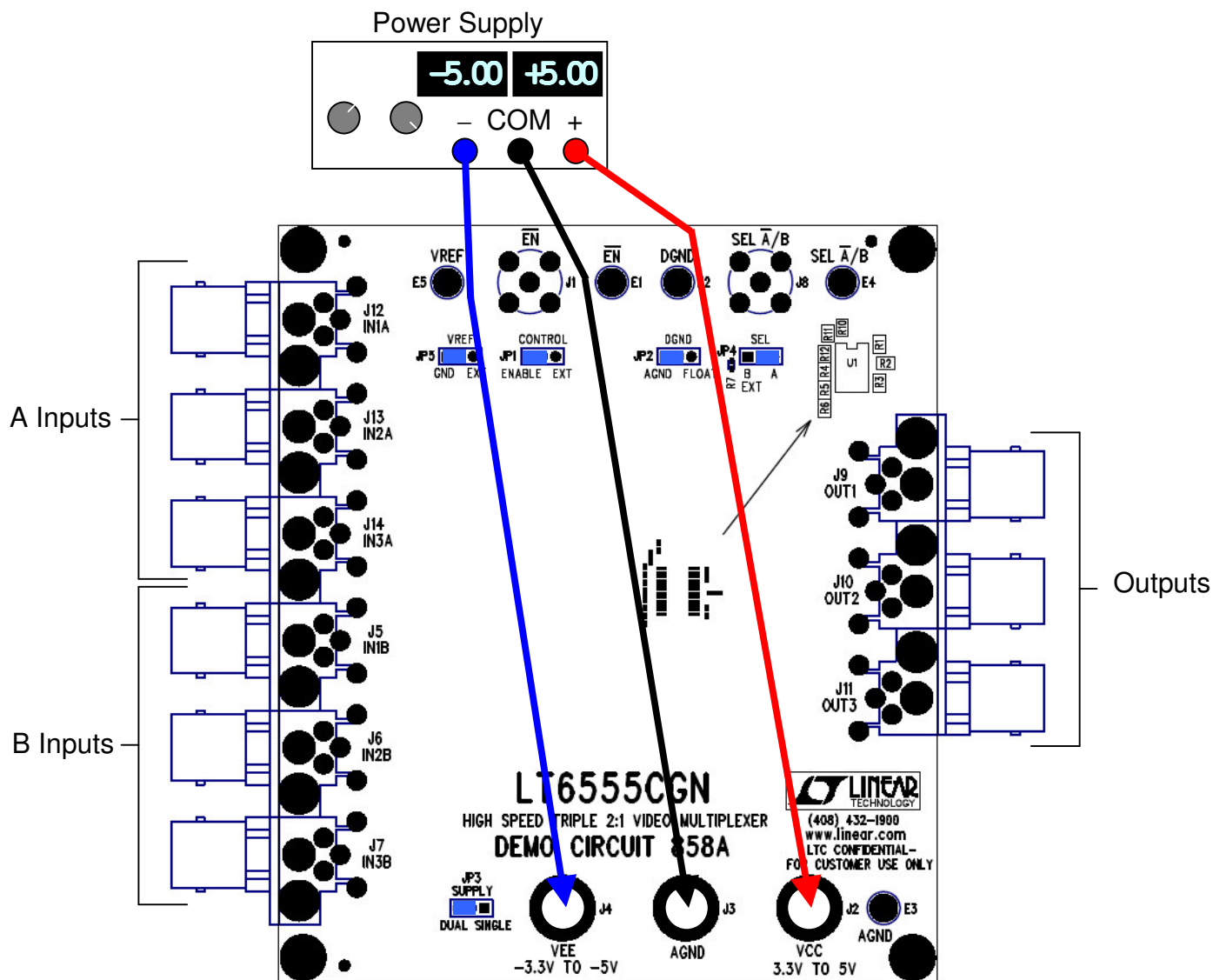

Figure 1. Recommended Demo Circuit Setup

## OPERATING PRINCIPLES

DC858 provides three identical channels of 2-way selectable wideband signal amplification suitable for driving HDTV or high-resolution RGB video display cables. Each amplifier section of the LT6555 includes a dual-input selection circuit (MUX) and an internally fixed gain of 2. With series back-termination resistors at the outputs (included on the board), the overall result is unity gain transmission of a selected video signal to a destination load. Each input is continually terminated to analog ground to properly load the input signal cables.

Refer to Figure 3 for the material list of the components used by DC858, and to Figure 4 for the electrical interconnection.

To minimize ingress of external digital ground noise, the DGND logic reference input is decoupled from analog ground within the LT6555. DC858 includes a jumper, JP2, which allows the DGND to be strapped to the local analog ground (AGND). This is used, for example, when the logic source is floating or none is used during the evaluation. DGND may be left uncommitted with JP2 in the FLOAT position.

## QUICK START PROCEDURE

Demonstration circuit 858 is easy to set up to evaluate the performance of the LT6555. Refer to Figure 1 for proper measurement equipment setup and follow the procedure below:

NOTE. Due to the Ultra High Frequencies (UHF) involved, RF measurement practices are required to accurately evaluate the performance of the LT6555.

1. Place jumpers in the following positions:

<b>JP1</b>	ENABLE
<b>JP2</b>	AGND
<b>JP3</b>	DUAL
<b>JP4</b>	A
<b>JP5</b>	GND

Another jumper, JP1, allows the LT6555 to be forced to an ENABLE condition. If JP1 is left in the EXTERNAL position, then enabling the LT6555 is accomplished by pulling down the EN connection to a level near that of DGND via connection at E1 or J1. A pull-up resistor internal to the LT6555 will provide a default shutdown mode of operation if the control input is left open-circuit. NOTE: DO NOT open-circuit EN if V+ is more than 5.5V above DGND; refer to the LT6555 datasheet for application details in this situation.

JP3 is provided as a convenience to eliminate having to externally short V- to GND in the case of SINGLE supply operation. Leave JP3 in the DUAL position when using split supplies.

JP4 is provided to allow fixed selection of either the A or B inputs, or if in the B position, the optional introduction of an external SEL A/B control signal at J8 or E4.

JP5 provides a means of grounding the VREF input of the LT6555 in the GND position. An external VREF voltage can be provided via E5 with JP5 in the EXTERNAL position.

2. Prior to connecting the power supply, preset the output voltages to  $\pm 5V$ , or to the desired level, if different.
3. With power off, connect the power supplies to VCC, VEE, and GND using banana-plug cables.
4. If using a Network Analyzer, perform the THRU transmission cal. with all cabling, adapters, impedance converters, etc. in place as the reference 0dB path.
5. Energize the power supply.
6. Connect the Network Analyzer (if used) to the appropriate channels to measure frequency response and crosstalk as desired.
7. For video-signal evaluation, connect a component-video signal source to the A inputs and a monitor

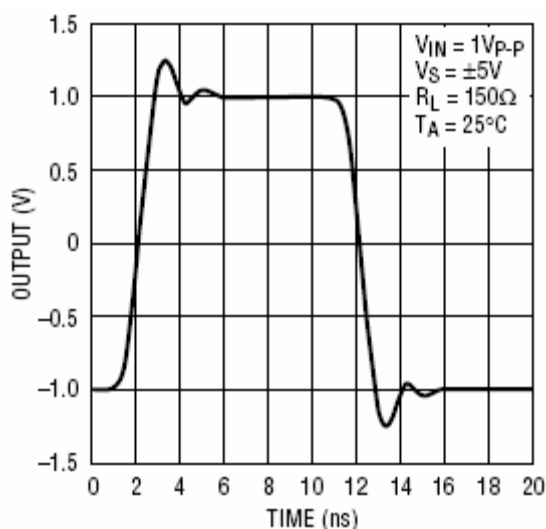

Figure 2. Typical Time-Domain Transmission Response

Item	Qty	Reference	Part Description	Manufacture / Part #
1	3	C1,C5,C10	CAP., X7R, 4700PF, 25V, 10%, 0402	AVX, 04023C472KAT1A
2	4	C2,C3,C6,C7	CAP., X7R, 470PF, 25V, 10%, 0402	AVX, 04023C471KAT1A
3	2	C4,C9	CAP., X7R, 10UF, 16V, 20%, 1206	TDK, C3216X7R1C106M
4	2	C8,C11	CAP., X5R, 0.33UF, 10V, 10%, 0402	TDK, C1005X5R1A334K
5	5	E1,E2,E3,E4,E5	TP, TURRET, .094"	MILL-MAX, 2501-2
6	5	JP1,JP2,JP3,JP4,JP5	JMP, 3PIN 1 ROW .079CC	COMM-CON, 2802S-03-G2
7	5	SHUNTS FOR JP1-JP5	SHUNT, .079" CENTER	COMM-CON CCIJ2MM-138G
8	2	J1,J8	CONN, BNC, 5 PINS	CONNEX, 112404
9	3	J2,J3,J4	JACK, BANANA,KEY-575	KEYSTONE, 575-4
10	9	J5,J6,J7,J9-J14	CONN, BNC, RIGHT ANGLE	CANARE, BCJ-BPLH
11	9	SCREW FOR J5,J6,J7,J9-J14	SCREW, PC MOUNT	CANARE, M2.6
12	9	R1-R6,R10-R12	RES., CHIP, 75 OHMS, 1/16W, 5% 0402	AAC, CR05-750JM
15	1	R7	RES., CHIP, 20K OHMS, 1/16W, 5% 0402	AAC, CR05-203JM
16	0	R8,R9	RES., CHIP, 0402	TBD
17	1	U1	IC., LT6555CGN, SSOP24GN	LINEAR, LT6555CGN
18	4	FOR 4 MTG	STAND-OFF NYLON 0.25" (SNAP ON)	KEYSTONE, 8831

Figure 3. DC858 Bill of Material

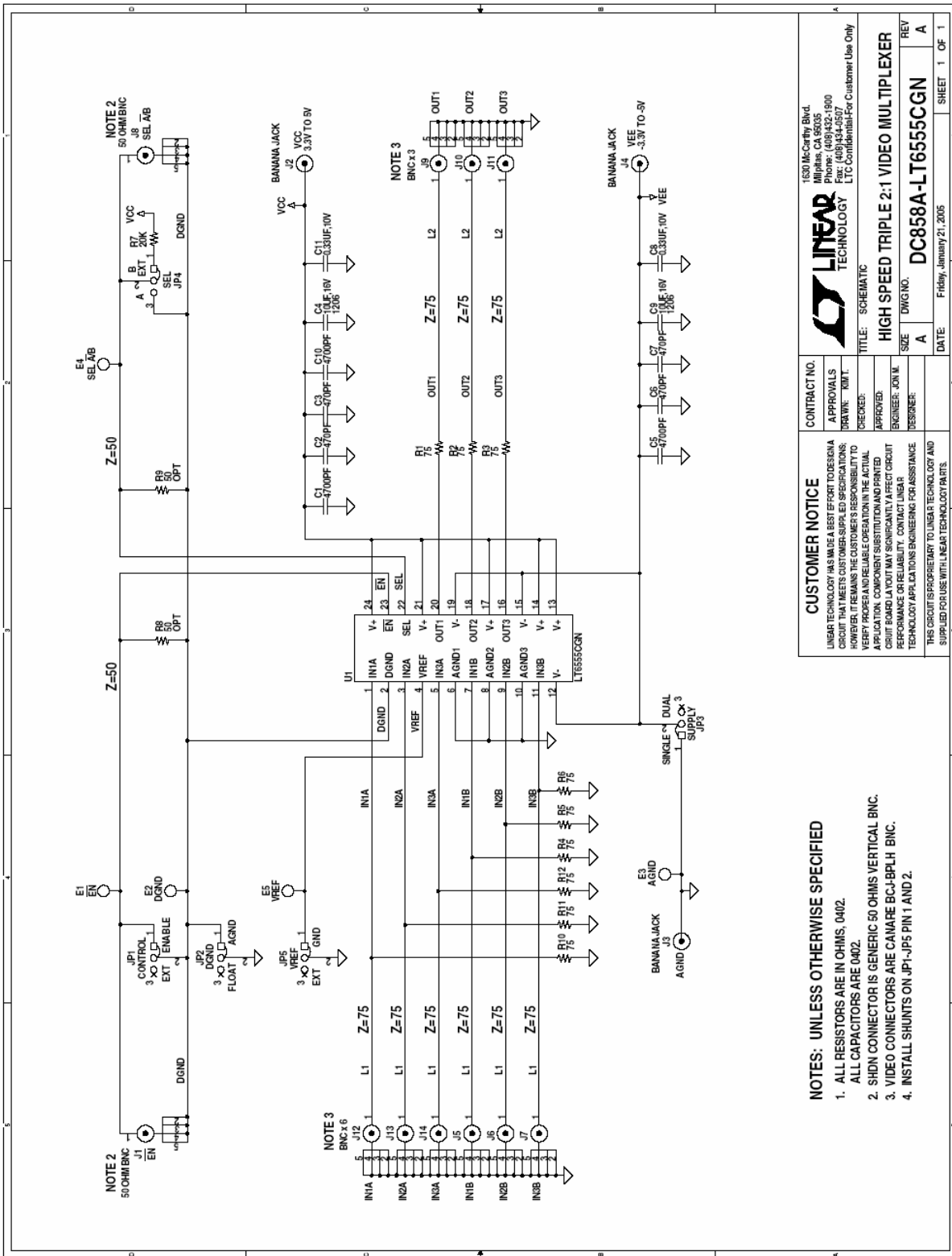

Figure 4. DC858 Electrical Schematic Diagram

**NOTES: UNLESS OTHERWISE SPECIFIED**

1. ALL RESISTORS ARE IN OHMS, 0402.
2. SHDN CONNECTOR IS GENERIC 50 OHMS VERTICAL BNC.
3. VIDEO CONNECTORS ARE CANARE BCJ-BPLH BNC.
4. INSTALL SHUNTS ON JPI-JP5 PIN1 AND 2.

<b>CUSTOMER NOTICE</b>		CONTRACT NO.
LINEAR TECHNOLOGY HAS MADE A BEST EFFORT TO DESIGN A CIRCUIT THAT MEETS CUSTOMER-SUPPLIED SPECIFICATIONS. CUSTOMER AGREES TO HOLD LINEAR TECHNOLOGY HARMLESS FROM LIABILITY TO THE EXTENT PERMITTED BY LAW FOR ANY DAMAGE TO PERSONAL PROPERTY, LOSS OF DATA, OR LOSS OF BUSINESS OPPORTUNITY, ARISING OUT OF THE ACTUAL APPLICATION COMPONENT SUBSTITUTION AND PRINTED CIRCUIT BOARD LAYOUT MAY SIGNIFICANTLY AFFECT CIRCUIT PERFORMANCE OR RELIABILITY. CONTACT LINEAR TECHNOLOGY APPLICATIONS ENGINEERING FOR ASSISTANCE.		APPROVALS DRAWN: KM.T.
THIS CIRCUIT IS PROPRIETARY TO LINEAR TECHNOLOGY AND SHOULD NOT BE REPRODUCED OR COPIED WITHOUT THE WRITTEN PERMISSION OF LINEAR TECHNOLOGY.		CREATED:
		APPROVED:
		ENGINEER: JON M.
		DESIGNER:

<p>1830 McCarthy Blvd. Milpitas, CA 95035 Phone: (415) 964-5200 Fax: (415) 964-5207 LTC Confidential-For Customer Use Only</p>		REV
<p>TITLE: SCHEMATIC</p> <p><b>HIGH SPEED TRIPLE 2:1 VIDEO MULTIPLEXER</b></p>		A
SIZE	DWG NO.	REV
A	DC858A-LT6555CGN	A
DATE	Fri, Jan 21, 2005	SHEET 1 OF 1

## Данный компонент на территории Российской Федерации

### Вы можете приобрести в компании MosChip.

Для оперативного оформления запроса Вам необходимо перейти по данной ссылке:

<http://moschip.ru/get-element>

Вы можете разместить у нас заказ для любого Вашего проекта, будь то серийное производство или разработка единичного прибора.

В нашем ассортименте представлены ведущие мировые производители активных и пассивных электронных компонентов.

Нашей специализацией является поставка электронной компонентной базы двойного назначения, продукции таких производителей как XILINX, Intel (ex.ALTERA), Vicor, Microchip, Texas Instruments, Analog Devices, Mini-Circuits, Amphenol, Glenair.

Сотрудничество с глобальными дистрибьюторами электронных компонентов, предоставляет возможность заказывать и получать с международных складов практически любой перечень компонентов в оптимальные для Вас сроки.

На всех этапах разработки и производства наши партнеры могут получить квалифицированную поддержку опытных инженеров.

Система менеджмента качества компании отвечает требованиям в соответствии с ГОСТ Р ИСО 9001, ГОСТ РВ 0015-002 и ЭС РД 009

### Офис по работе с юридическими лицами:

105318, г.Москва, ул.Щербаковская д.3, офис 1107, 1118, ДЦ «Щербаковский»

Телефон: +7 495 668-12-70 (многоканальный)

Факс: +7 495 668-12-70 (доб.304)

E-mail: [info@moschip.ru](mailto:info@moschip.ru)

Skype отдела продаж:

moschip.ru

moschip.ru\_4

moschip.ru\_6

moschip.ru\_9