

DIN 48 x 24-mm Total Counter/Time Counter with Easy-to-read Displays and Water and Oil Resistance Equivalent to IP66

- High-visibility, negative transmissive LCD display with 8.5-mm-high characters and built-in red LED backlight at low power consumption.
- IP66 with oil resistance and NEMA 4 protection achieved by unifying the front with the case and by using oil-resistant parts and materials.
- Compact (80 mm) body.
- Just change a switch setting for either an NPN or PNP input.
- Supports both external resetting and manual resetting.
- Finger-protection terminal block cover prevents electrical shock and conforms to VDE0106, Part 100.
- Certified for UL and CSA safety standards.
- Complies with EMC standards (EN 61326) and CE Marking.



Model Number Structure

Model Number Legend

H7GP-□□□
1 2 3

1. Classification

- C: Total counter
- T: Time counter

2. Supply Voltage

- None: 100 to 240 VAC
- D: 12 to 24 VDC

3. Case Color of Front Section

- None: Light gray (Munsell 5Y7/1)
- B: Black

Ordering Information

List of Models

Total counter

Supply voltage	6-digit total counter	
	Light gray	Black
100 to 240 VAC	H7GP-C	H7GP-CB
12 to 24 VDC	H7GP-CD	H7GP-CDB

Time counter

Supply voltage	6-digit time counter	
	Light gray	Black
100 to 240 VAC	H7GP-T	H7GP-TB
12 to 24 VDC	H7GP-TD	H7GP-TDB

Specifications

■ Ratings

Item	6-digit total counter		6-digit time counter	
	H7GP-C	H7GP-CD	H7GP-T	H7GP-TD
Rated supply voltage	100 to 240 VAC (50/60 Hz)	12 to 24 VDC (see note 1)	100 to 240 VAC (50/60 Hz)	12 to 24 VDC (see note 1)
External power supply	50 mA at 12 VDC	---	50 mA at 12 VDC	---
Operating voltage range	85% to 110% of rated supply voltage			
Power consumption	100 to 240 VAC: 6.5 VA max. 12 to 24 VDC: 0.6 W max.			
Dimensions	48 x 24 x 80 mm (W x H x D)			
Mounting method	Flush mounting			
External connections	Screw terminals			
Degree of protection	Panel surface: IP66 with oil resistance and NEMA Type 4 (indoors).			
Display	7-segment, negative transmissive LCD (with red backlight)			
Digits	6 digits (8.5-mm-high characters)			
Input mode	Up (increment)		Accumulative	
Max. counting speeds	30 Hz or 5 kHz (selected via DIP switch)		---	
Counting range	0 to 999999		---	
Time specification	---		0.1 to 99999.9 h/1 s to 99 h 59 min 59 s	
Timing accuracy	---		±100 ppm (−10°C to 55°C)	
Memory backup	EEP-ROM: 200,000 operations min.			
Input	Input signals	Count, reset, and key protection (see note 2)		Start, reset, and key protection (see note 2)
	Input method	No-voltage input (NPN transistor input) or voltage input (PNP transistor input) (selected via DIP switch)		
	Count, reset, start	No-voltage input (NPN transistor input) Short-circuit (ON) impedance: 1 kΩ max. Short-circuit (ON) residual voltage: 2 VDC max. Open (OFF) impedance: 100 kΩ min. Voltage input (PNP transistor input) Short-circuit (ON) impedance: 1 kΩ max. ON voltage: 9 to 24 VDC OFF voltage: 5 VDC max. Open (OFF) impedance: 100 kΩ max.		
	Key protection	No-voltage input (NPN transistor input) Short-circuit (ON) impedance: 1 kΩ max. Short-circuit (ON) residual voltage: 0.5 VDC max. Open (OFF) impedance: 100 kΩ min.		
Input response speed	Reset	20 or 1 ms (automatically switched according to counting speed)	20 ms	
	Start	---	20 ms	
	Key protection	Approx. 1 s	Approx. 1 s	
Reset system	External and manual resets			

Note: 1. Contains 20% ripple (p-p) max.

2. Only a non-voltage input (NPN transistor) is possible for the key protection input. The key protection input will be a non-voltage input even if the NPN/PNP input mode is set to PNP. Key protection is used to prohibit operating the Reset Key. The reset input terminals will still be functional.

■ Characteristics

Insulation resistance	100 MΩ min. (at 500 VDC)
Dielectric strength	2,000 VAC, 50/60 Hz for 1 min between current-carrying terminal and exposed non-current-carrying metal parts (AC model) 1,000 VAC, 50/60 Hz for 1 min between current-carrying terminal and exposed non-current-carrying metal parts (DC model) 2,000 VAC, 50/60 Hz for 1 min between power terminals and control input terminals (AC model)
Impulse withstand voltage	3 kV (between power terminals) (1 kV for 12-to-24-VDC models) 4.5 kV (between current-carrying terminal and exposed non-current-carrying metal parts) (1.5 kV for 12-to-24-VDC models)
Noise immunity	±1.5 kV (between AC power terminals), ±480 V (between DC power terminals), ±480 V (between input terminals); square-wave noise by noise simulator (pulse width: 100 ns/1 μs, 1-ns rise)
Static immunity	Display: Malfunction:8 kV Destruction:15 kV DIP switch: Malfunction:4 kV Destruction:8 kV
Vibration resistance	Destruction: 10 to 55 Hz with 0.75-mm single amplitude, 2 hours each in three directions Malfunction: 10 to 55 Hz with 0.5-mm single amplitude, 10 minutes each in three directions
Shock resistance	Destruction: 294 m/s ² each in three directions Malfunction: 196 m/s ² each in three directions
Ambient temperature	Operating: -10°C to 55°C (with no icing) Storage: -25°C to 65°C (with no icing)
Ambient humidity	Operating: 35% to 85%
EMC	(EMI) EN61326 Emission Enclosure: EN55011 Group 1 class A Emission AC Mains: EN55011 Group 1 class A (EMS) EN61326 Immunity ESD: EN61000-4-2: 4 kV contact discharge (level 2) 8 kV air discharge (level 3) Immunity RF-interference: EN61000-4-3: 10 V/m (Amplitude-modulated, 80 MHz to 1 GHz) (level 3); 10 V/m (Pulse-modulated, 900 MHz ±5 MHz) (level 3) Immunity Conducted Disturbance: EN61000-4-6: 10 V (0.15 to 80 MHz) (according to EN61000-6-2) Immunity Burst: EN61000-4-4: 2 kV power-line (level 3); 2 kV I/O signal-line (level 4) Immunity Surge: EN61000-4-5: 1 kV line to lines (power and output lines) (level 2); 2 kV line to ground (power and output lines) (level 3) Immunity Voltage Dip/Interruption: EN61000-4-11: 0.5 cycle, 100% (rated voltage)
Approved standards	UL508, CSA22.2 No.14, conforms to EN61010-1, VDE0106/P100
Case color	Rear section: Gray smoke; Front section: 5Y7/1 (light gray) or N1.5 (black)
Weight	Approx. 75 g

Connections

Terminal Arrangement

Note: Non-contact input is also available.

AC Models

H7GP-C

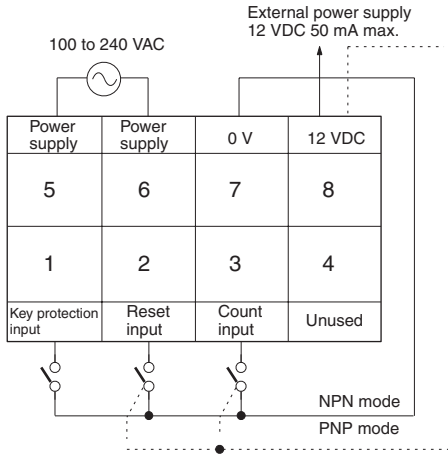

H7GP-T

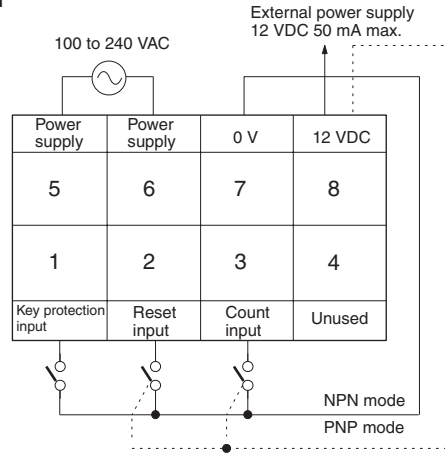

DC Models

H7GP-CD

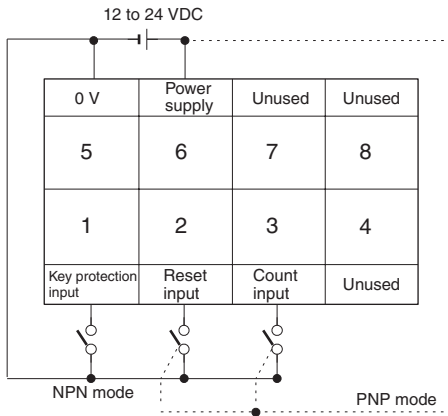

H7GP-TD

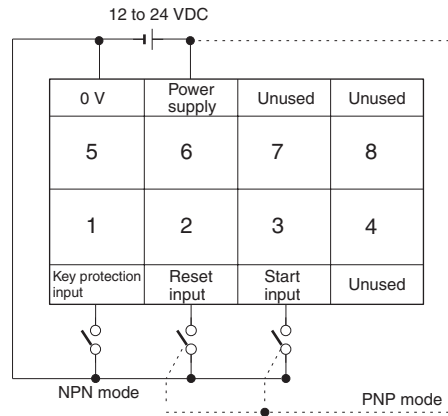

Operation

DIP Switch Settings

Set all DIP switches before mounting the Counter to a control panel. All switches are set toward the display panel before shipping.

H7GP-C/-CD

Switch	Item	Function	
3 (On right side from front)	Input mode (note 1)	Display side	NPN
		Terminal side	PNP
4 (On left side from front)	Counting speed (note 1)	Display side	30 Hz
		Terminal side	5 kHz

H7GP-T/-TD

Switch	Item	Function	
3 (On right side from front)	Input mode (note 1)	Display side	NPN
		Terminal side	PNP
4 (On left side from front)	Time range (note 1)	Display side	99999.9h (note 2)
		Terminal side	99 h 59 min 59 s

Note: 1. When the setting has been changed, turned power off and on to continue. The display will show "0" when the power is turned back on.

2. The decimal point will flash every second when "99999.9 h" is set.

Operating Modes

Total Counters

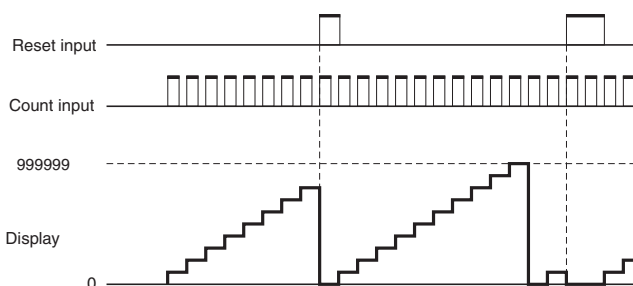

Note: The count value will return to "0" when "999999" is exceeded. The display and output are turned OFF when the power supply turns OFF, but the count value is stored internally.

Time Counters

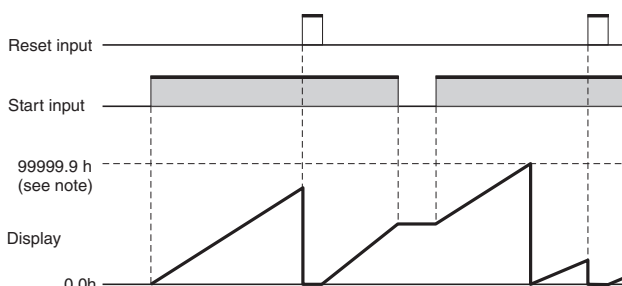

Note: Display values are shown for full scale set to 99999.9 h. The count value will return to "0" when "99999.9" is exceeded. The display and output are turned OFF when the power supply turns OFF, but the count value is stored internally.

Nomenclature

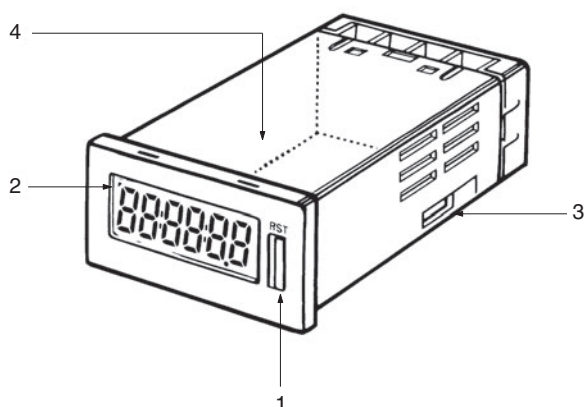

- Reset Key**
Resets the count value, but will not operate while the keys are protected.
- Key Protection Indicator**
Lit while the keys are protected. (Reset Key is disabled.).
- NPN/PNP DIP Switch**
(Count or start with reset)
When the setting has been changed, turned power off and on to continue. The display will show "0" when the power is turned back on. See below for details.
- Counting Speed DIP Switch (H7GP-C)**
Time Range DIP Switch (H7GP-T)
When the setting has been changed, turned power off and on to continue. The display will show "0" when the power is turned back on. Refer to *DIP Switch Setting* for details.

Dimensions

Note: All units are in millimeters unless otherwise indicated.

H7GP-C
H7GP-T

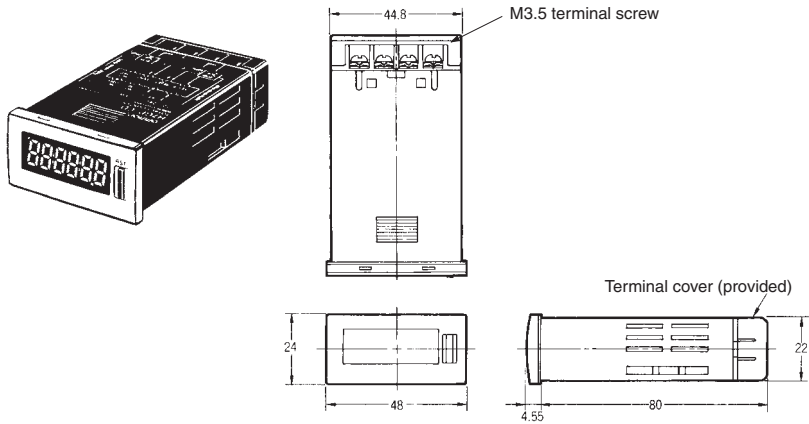

Panel Cutouts

Panel cutouts are as shown below (according to DIN43700).

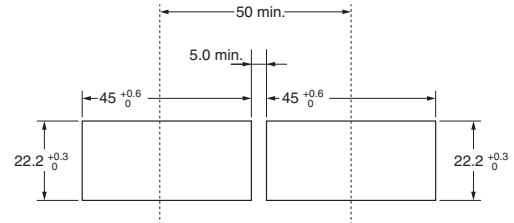

Note: 1. The mounting panel thickness should be 1 to 6 mm.

2. Water resistance will be lost if Counters are mounted side-by-side.

3. The terminal screws are M3.5. (The effective thread length is 6 mm.)

4. When horizontally mounting Counters side-by-side, leave at least 50 mm between any two Counters.

With Flush Mounting Bracket

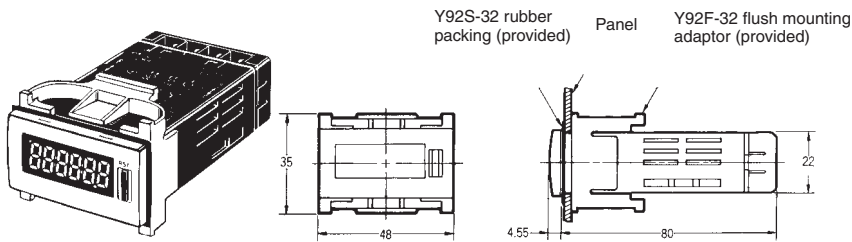

ALL DIMENSIONS SHOWN ARE IN MILLIMETERS.
To convert millimeters into inches, multiply by 0.03937. To convert grams into ounces, multiply by 0.03527.

In the interest of product improvement, specifications are subject to change without notice.

Read and Understand This Catalog

Please read and understand this catalog before purchasing the products. Please consult your OMRON representative if you have any questions or comments.

Warranty and Limitations of Liability

WARRANTY

OMRON's exclusive warranty is that the products are free from defects in materials and workmanship for a period of one year (or other period if specified) from date of sale by OMRON.

OMRON MAKES NO WARRANTY OR REPRESENTATION, EXPRESS OR IMPLIED, REGARDING NON-INFRINGEMENT, MERCHANTABILITY, OR FITNESS FOR PARTICULAR PURPOSE OF THE PRODUCTS. ANY BUYER OR USER ACKNOWLEDGES THAT THE BUYER OR USER ALONE HAS DETERMINED THAT THE PRODUCTS WILL SUITABLY MEET THE REQUIREMENTS OF THEIR INTENDED USE. OMRON DISCLAIMS ALL OTHER WARRANTIES, EXPRESS OR IMPLIED.

LIMITATIONS OF LIABILITY

OMRON SHALL NOT BE RESPONSIBLE FOR SPECIAL, INDIRECT, OR CONSEQUENTIAL DAMAGES, LOSS OF PROFITS OR COMMERCIAL LOSS IN ANY WAY CONNECTED WITH THE PRODUCTS, WHETHER SUCH CLAIM IS BASED ON CONTRACT, WARRANTY, NEGLIGENCE, OR STRICT LIABILITY.

In no event shall the responsibility of OMRON for any act exceed the individual price of the product on which liability is asserted.

IN NO EVENT SHALL OMRON BE RESPONSIBLE FOR WARRANTY, REPAIR, OR OTHER CLAIMS REGARDING THE PRODUCTS UNLESS OMRON'S ANALYSIS CONFIRMS THAT THE PRODUCTS WERE PROPERLY HANDLED, STORED, INSTALLED, AND MAINTAINED AND NOT SUBJECT TO CONTAMINATION, ABUSE, MISUSE, OR INAPPROPRIATE MODIFICATION OR REPAIR.

Application Considerations

SUITABILITY FOR USE

OMRON shall not be responsible for conformity with any standards, codes, or regulations that apply to the combination of products in the customer's application or use of the products.

At the customer's request, OMRON will provide applicable third party certification documents identifying ratings and limitations of use that apply to the products. This information by itself is not sufficient for a complete determination of the suitability of the products in combination with the end product, machine, system, or other application or use.

The following are some examples of applications for which particular attention must be given. This is not intended to be an exhaustive list of all possible uses of the products, nor is it intended to imply that the uses listed may be suitable for the products:

- Outdoor use, uses involving potential chemical contamination or electrical interference, or conditions or uses not described in this catalog.
- Nuclear energy control systems, combustion systems, railroad systems, aviation systems, medical equipment, amusement machines, vehicles, safety equipment, and installations subject to separate industry or government regulations.
- Systems, machines, and equipment that could present a risk to life or property.

Please know and observe all prohibitions of use applicable to the products.

NEVER USE THE PRODUCTS FOR AN APPLICATION INVOLVING SERIOUS RISK TO LIFE OR PROPERTY WITHOUT ENSURING THAT THE SYSTEM AS A WHOLE HAS BEEN DESIGNED TO ADDRESS THE RISKS, AND THAT THE OMRON PRODUCTS ARE PROPERLY RATED AND INSTALLED FOR THE INTENDED USE WITHIN THE OVERALL EQUIPMENT OR SYSTEM.

PROGRAMMABLE PRODUCTS

OMRON shall not be responsible for the user's programming of a programmable product, or any consequence thereof.

Disclaimers

CHANGE IN SPECIFICATIONS

Product specifications and accessories may be changed at any time based on improvements and other reasons.

It is our practice to change model numbers when published ratings or features are changed, or when significant construction changes are made. However, some specifications of the products may be changed without any notice. When in doubt, special model numbers may be assigned to fix or establish key specifications for your application on your request. Please consult with your OMRON representative at any time to confirm actual specifications of purchased products.

DIMENSIONS AND WEIGHTS

Dimensions and weights are nominal and are not to be used for manufacturing purposes, even when tolerances are shown.

PERFORMANCE DATA

Performance data given in this catalog is provided as a guide for the user in determining suitability and does not constitute a warranty. It may represent the result of OMRON's test conditions, and the users must correlate it to actual application requirements. Actual performance is subject to the OMRON Warranty and Limitations of Liability.

ERRORS AND OMISSIONS

The information in this document has been carefully checked and is believed to be accurate; however, no responsibility is assumed for clerical, typographical, or proofreading errors, or omissions.

2011.10

In the interest of product improvement, specifications are subject to change without notice.

OMRON Corporation
Industrial Automation Company

<http://www.ia.omron.com/>

(c)Copyright OMRON Corporation 2011 All Right Reserved.

Данный компонент на территории Российской Федерации

Вы можете приобрести в компании MosChip.

Для оперативного оформления запроса Вам необходимо перейти по данной ссылке:

<http://moschip.ru/get-element>

Вы можете разместить у нас заказ для любого Вашего проекта, будь то серийное производство или разработка единичного прибора.

В нашем ассортименте представлены ведущие мировые производители активных и пассивных электронных компонентов.

Нашей специализацией является поставка электронной компонентной базы двойного назначения, продукции таких производителей как XILINX, Intel (ex.ALTERA), Vicor, Microchip, Texas Instruments, Analog Devices, Mini-Circuits, Amphenol, Glenair.

Сотрудничество с глобальными дистрибьюторами электронных компонентов, предоставляет возможность заказывать и получать с международных складов практически любой перечень компонентов в оптимальные для Вас сроки.

На всех этапах разработки и производства наши партнеры могут получить квалифицированную поддержку опытных инженеров.

Система менеджмента качества компании отвечает требованиям в соответствии с ГОСТ Р ИСО 9001, ГОСТ РВ 0015-002 и ЭС РД 009

Офис по работе с юридическими лицами:

105318, г.Москва, ул.Щербаковская д.3, офис 1107, 1118, ДЦ «Щербаковский»

Телефон: +7 495 668-12-70 (многоканальный)

Факс: +7 495 668-12-70 (доб.304)

E-mail: info@moschip.ru

Skype отдела продаж:

moschip.ru

moschip.ru_4

moschip.ru_6

moschip.ru_9