

LCD Segment Drivers

Standard Segment Drivers



BU9795AKV, BU9795AFV, BU9795AGUW, BU9794AKV, BU97950FUV

No.10044EAT06

●Description

ROHM standard function segment driver series achieve "Ultra-Low power consumption". Also these drivers need not external components. And this driver series is very simple that only has segment driver function. So, these driver series are very suitable to add in LCD display function for various applications.

●Features (BU9795AKV/FV/GUW, BU9794AKV)

- 1) 3wire serial interface
- 2) Integrated RAM for display data (DDRAM)
- 3) Power supply circuit for LCD driving
 - 1/2, 1/3 Bias selectable
 - 1/4 Duty
 - Integrated Buffer AMP
- 4) Integrated Oscillation circuit
- 5) Integrated Power-on Reset circuit
- 6) No external components
- 7) Support blink function
- 8) Support standby mode
- 9) Low voltage / Ultra low power consumption design
- 10) Support unity voltage supply (BU9795AKV/FV/GUW)
- 11) Support Independent power supply circuit for LCD driving (BU9794AKV)

●Features (BU97950FUV)

- 1) 2wire serial interface
- 2) Integrated RAM for display data (DDRAM)
- 3) Integrated Power supply circuit for LCD driving
 - 1/4 Bias 1/8 Duty
 - Integrated Buffer AMP
- 4) Integrated Oscillation circuit
- 5) Integrated Power-on Reset circuit
- 6) No external components
- 7) Support standby mode
- 8) Low voltage / Ultra low power consumption design
- 9) Integrated Electrical volume register (EVR) function
- 10) Support Register Read function
- 11) Support Independent power supply circuit for LCD driving

●Applications

Telephone, FAX, Portable equipment (POS, ECR, PDA etc.),
DSC, DVC, Car Audio, Home electrical appliance, Meter equipment, Healthcare equipment etc.

●Line up matrix

Parameter	BU9795A			BU9794AKV	BU97950FUV
	KV	FV	GUW		
Segment output	35	27	31	50	35
Common output	4	4	4	4	8
Total display dot number	140	108	124	200	280
Adjustable contrast function	-	-	-	-	Yes
Support split voltage supply	-	-	-	Yes	Yes
Interface	3wire	3wire	3wire	3wire	2wire
Package	VQFP48C	SSOP-B40	VBGA48W040	VQFP64	TSSOP-C48V

●Absolute maximum ratings (VSS=0V)

Parameter	BU9795AKV /FV/GUW	BU9794AKV	BU97950FUV	Unit	Remarks
Power Supply Voltage 1 (VDD)	-0.5~+7.0			V	Power supply
Power Supply Voltage 2 (VLCD)	-0.5~VDD	-0.5~+7.0	-0.5~+7.0	V	LCD drive Voltage
Allowable Loss (Pd)	0.6* ¹ 0.7* ² 0.27* ³	0.75* ⁴	0.75* ⁴	W	Allowable loss at package only
Input Voltage Range (VIN)	-0.5~VDD+0.5			V	
Operational Temperature Range (Topr)	-40~+85			°C	
Storage Temperature Range (Tstg)	-55~+125			°C	

*1 When use more than Ta=25°C, subtract 6.0mW per degree (BU9795AKV)

*2 When use more than Ta=25°C, subtract 7.0mW per degree (BU9795AFV)

*3 When use more than Ta=25°C, subtract 2.7mW per degree (BU9795AGUW)

*4 When use more than Ta=25°C, subtract 7.5mW per degree (BU9794AKV, BU97950FUV)

●Recommend operating conditions (Ta=-40~85°C, VSS=0V)

Parameter	BU9795AKV /FV/GUW*1			BU9794AKV			BU97950KV			Unit	Remarks
	Min.	Typ.	Max.	Min.	Typ.	Max.	Min.	Typ.	Max.		
Power Supply Voltage 1 (VDD)	2.5	-	5.5	2.5	-	5.5	2.5	-	5.5	V	Power supply
Power Supply Voltage 2 (VLCD)	0	-	VDD-2.4	2.5	-	5.5	2.5	-	5.5	V	LCD drive Voltage

*1 Please use VDD-VLCD ≥ 2.4V condition.

●Electrical characteristics

<BU9795AKV/FV/GUW>

DC Characteristics (VDD=2.5~5.5V, VSS=0V, Ta=-40~85°C, unless otherwise specified)

Parameter	Symbol	Limits			Unit	Condition
		Min.	Typ.	Max.		
"H" level input voltage	VIH	0.7VDD	-	VDD	V	SD, SCL, CSB
"L" level input voltage	VIL	VSS	-	0.3VDD	V	SD, SCL, CSB
"H" level input current	I _{IH}	-	-	1	μA	SD, SCL, CSB
"L" level input current	I _{IL}	-1	-	-	μA	SD, SCL, CSB
LCD Driver on resistance	SEG	RON	-	3.5	-	I _{load} =±10μA
	COM	RON	-	3.5	-	
VLCD supply voltage	VLCD	0	-	VDD-2.4	V	VDD-VLCD ≥ 2.4V
Standby current	I _{st}	-	-	5	μA	Display off, Oscillator off
Power consumption 1	IDD1	-	12.5	30	μA	VDD=3.3[V], Ta=25°C, Power save mode1, FR=70Hz 1/3 bias, Frame inverse
Power consumption 2	IDD2	-	20	40	μA	VDD=3.3[V], Ta=25°C, Normal mode, FR=80Hz 1/3 bias, Line inverse

Oscillation Characteristics (VDD=2.5~5.5V, VSS=0V, Ta=-40~85°C)

Parameter	Symbol	Limits			Unit	Condition
		Min.	Typ.	Max.		
Frame frequency	f _{CLK}	56	80	104	Hz	FR = 80Hz setting
Frame frequency1	f _{CLK1}	70	80	90	Hz	VDD=3.5V, 25°C

MPU interface Characteristics(VDD=2.5V~5.5V, VSS=0V, Ta=-40~85°C)

Parameter	Symbol	Limits			Unit	Condition
		Min.	Typ.	Max.		
Input rise time	t _r	-	-	80	ns	
Input fall time	t _f	-	-	80	ns	
SCL cycle time	t _{SCYC}	400	-	-	ns	
"H" SCL pulse width	t _{SHW}	100	-	-	ns	
"L" SCL pulse width	t _{SLW}	100	-	-	ns	
SD setup time	t _{SDS}	20	-	-	ns	
SD hold time	t _{SDH}	50	-	-	ns	
CSB setup time	t _{CSS}	50	-	-	ns	
CSB hold time	t _{CSH}	50	-	-	ns	
"H" CSB pulse width	t _{CHW}	50	-	-	ns	

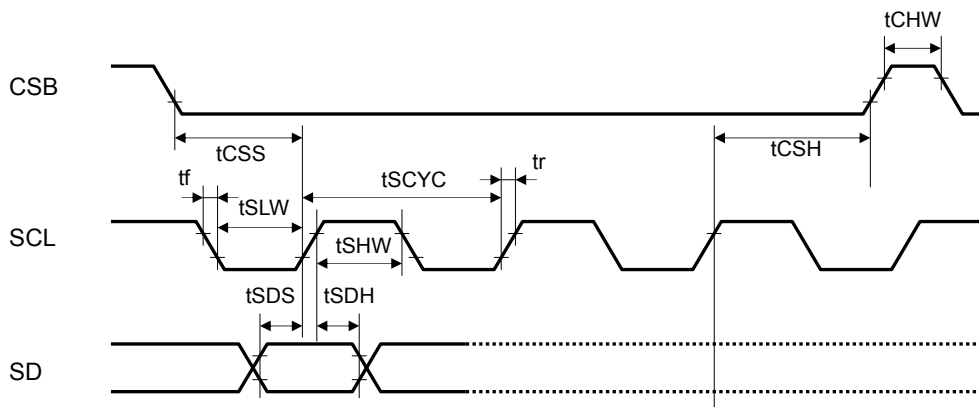

Fig.1 Interface Timing (BU9795AKV/FV/GUW)

<BU9794AKV>

DC Characteristics (VDD=2.5~5.5V, VLCD=2.5~5.5V, VSS=0V, Ta=-40~85°C, unless otherwise specified)

Parameter	Symbol	Limits			Unit	Condition
		Min.	Typ.	Max.		
“H” level input voltage	VIH	0.8VDD	-	VDD	V	SD,SCL,CSB
“L” level input voltage	VIL	VSS	-	0.2VDD	V	SD,SCL,CSB
“H” level input current	I _{IH}	-	-	1	μA	SD,SCL,CSB
“L” level input current	I _{IL}	-1	-	-	μA	SD,SCL,CSB
LCD Driver on resistance	SEG	RON	-	3.5	-	I _{load} =±10μA
	COM	RON	-	3.5	-	
Standby current	I _{st}	-	-	5	μA	Display off, Oscillation off
Power consumption 1	IDD	-	5	15	μA	VDD=3.3V, VLCD=5V, Ta=25°C Power save mode1, FR=70Hz 1/3 bias, Frame inverse
Power consumption 2	I _{LCD}	-	10	20	μA	VDD=3.3V, VLCD=5V, Ta=25°C Power save mode1, FR=70Hz 1/3 bias, Frame inverse

Oscillation Characteristics (VDD=2.5~5.5V, VLCD=2.5~5.5V, VSS=0V, Ta=-40~85°C, unless otherwise specified)

Parameter	Symbol	Limits			Unit	Condition
		Min.	Typ.	Max.		
Frame frequency	f _{CLK}	68	80	92	Hz	FR = 80Hz setting, VDD=3.3V

MPU interface Characteristics (VDD=2.5~5.5V, VLCD=2.5~5.5V, VSS=0V, Ta=-40~85°C, unless otherwise specified)

Parameter	Symbol	Limits			Unit	Condition
		Min.	Typ.	Max.		
Input rise time	t _r	-	-	80	ns	
Input fall time	t _f	-	-	80	ns	
SCL cycle time	t _{SCYC}	400	-	-	ns	
“H” SCL pulse width	t _{SHW}	100	-	-	ns	
“L” SCL pulse width	t _{SLW}	100	-	-	ns	
SD setup time	t _{SDS}	20	-	-	ns	
SD hold time	t _{SDH}	50	-	-	ns	
CSB setup time	t _{CSS}	50	-	-	ns	
CSB hold time	t _{CSH}	50	-	-	ns	
“H” CSB pulse time	t _{CHW}	50	-	-	ns	

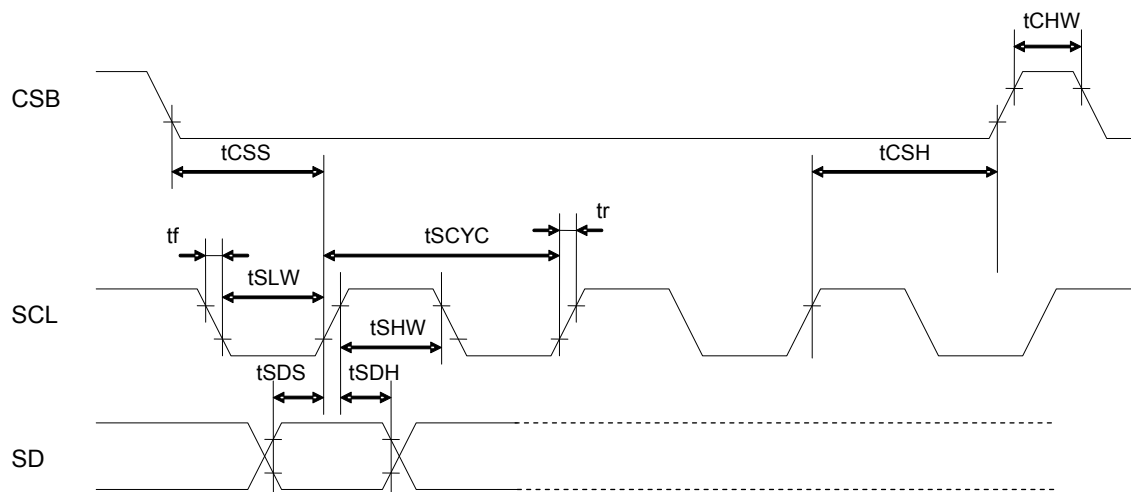

Fig.2 Interface Timing (BU9794AKV)

<BU97950FUV>

DC Characteristics (VDD=2.5~5.5V, VLCD=2.5~5.5V, VSS=0V, Ta=-40~85°C, unless otherwise specified)

Parameter	Symbol	Limits			Unit	Conditions
		Min.	Typ.	Max.		
"H" level input voltage	VIH	0.7VDD	-	VDD	V	SDA,SCL
"L" level input voltage	VIL	VSS	-	0.3VDD	V	SDA,SCL
"H" level input current	I _{IH}	-	-	1	μA	SDA,SCL
"L" level input current	I _{IL}	-1	-	-	μA	SDA,SCL
LCD Driver on resistance	SEG	RON	-	3.5	kΩ	I _{load} =±10μA
	COM	RON	-	3.5	kΩ	
Standby current	I _{st}	-	-	5	μA	Display off, Oscillation off
Power consumption 1	IDD	-	2.5	15	μA	VDD=3.3V, VLCD=5V, Ta=25°C Power save mode1, FR=80Hz 1/4 bias, Frame inverse
Power consumption 2	ILCD	-	10	20	μA	VDD=3.3V, VLCD=5V, Ta=25°C Power save mode1, FR=80Hz 1/4 bias, Frame inverse

Oscillation Characteristics (VDD=2.5~5.5V, VSS=0V, Ta=-40~85°C, unless otherwise specified)

Parameter	Symbol	Limits			Unit	Condition
		Min.	Typ.	Max.		
Frame frequency	f _{CLK}	56	80	104	Hz	Power save mode FR = Normal mode

MPU interface Characteristics (VDD=2.5~5.5V, VLCD=0V, VSS=0V, Ta=-40~85°C, unless otherwise specified)

Parameter	Symbol	Limits			Unit	Condition
		Min.	Typ.	Max.		
Input rise time	t _r	-	-	0.3	μs	
Input fall time	t _f	-	-	0.3	μs	
SCL cycle time	t _{SCYC}	2.5	-	-	μs	
"H" SCL pulse width	t _{SHW}	0.6	-	-	μs	
"L" SCL pulse width	t _{SLW}	1.3	-	-	μs	
SDA setup time	t _{SDS}	200	-	-	ns	
SDA hold time	t _{SDH}	0	-	-	ns	
Bus free time	t _{BUF}	1.3	-	-	μs	
START condition hold time	t _{HD;STA}	0.6	-	-	μs	
START condition setup time	t _{SU;STA}	0.6	-	-	μs	
STOP condition setup time	t _{SU;STO}	0.6	-	-	μs	

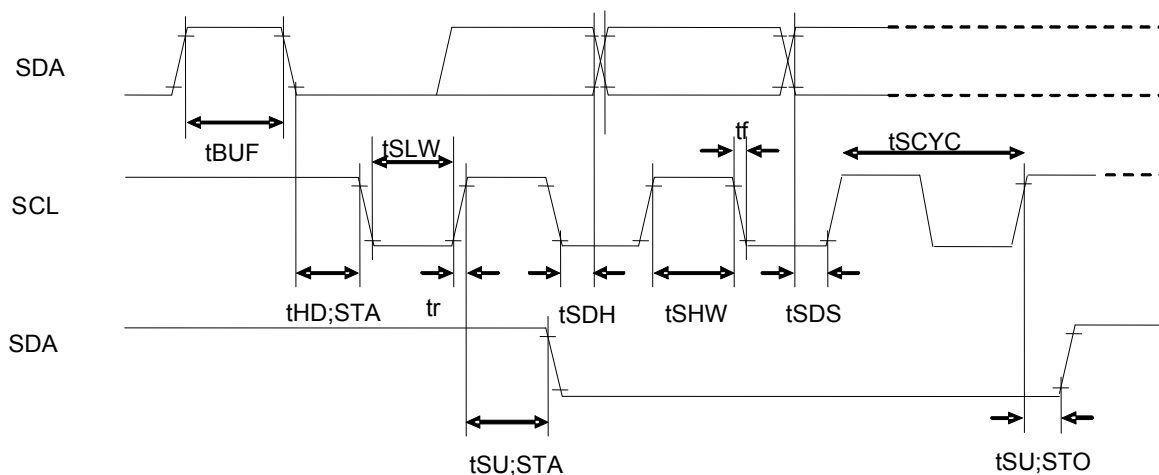

Fig.3 interface timing (BU97950FUV)

●Block Diagram / Pin Arrangement / Terminal Description

<BU9795AKV>

●Block Diagram

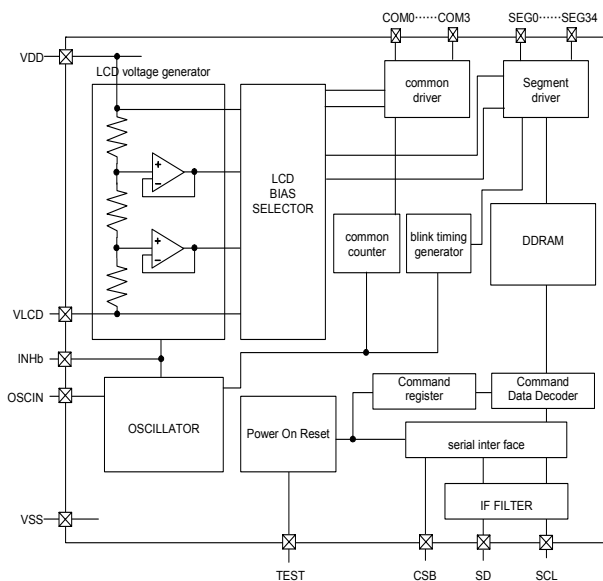

Fig.4 Block Diagram (BU9795AKV)

●Pin Arrangement

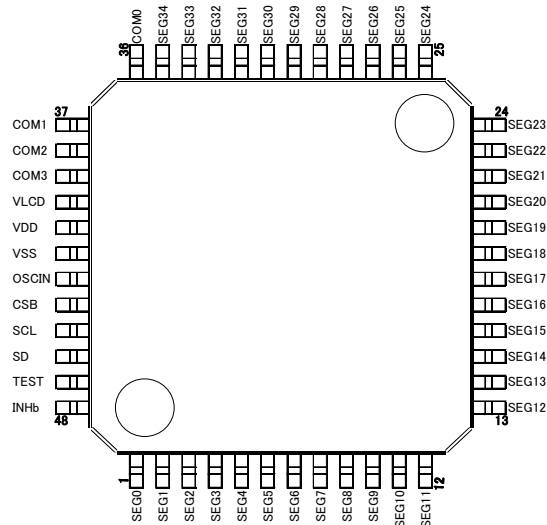

Fig.5 Pin Arrangement (BU9795AKV)

●Terminal Description

Terminal	Terminal No.	I/O	Function
INHb	48	I	Input terminal for turn off display H: turn on display L: turn off display
TEST	47	I	Test input (ROHM use only) Must be connect to VSS
OSCIN	43	I	External clock input Ext clock and Int clock can be changed by command. Must be connect to VSS when use internal oscillation circuit.
SD	46	I	serial data input
SCL	45	I	serial data transfer clock
CSB	44	I	Chip select : "L" active
VSS	42	-	GND
VDD	41	-	Power supply
VLCD	40	-	Power supply for LCD driving
SEG0-34	1-35	O	SEGMENT output for LCD driving
COM0-3	36-39	O	COMMON output for LCD driving

<BU9795AFV>
●Block Diagram

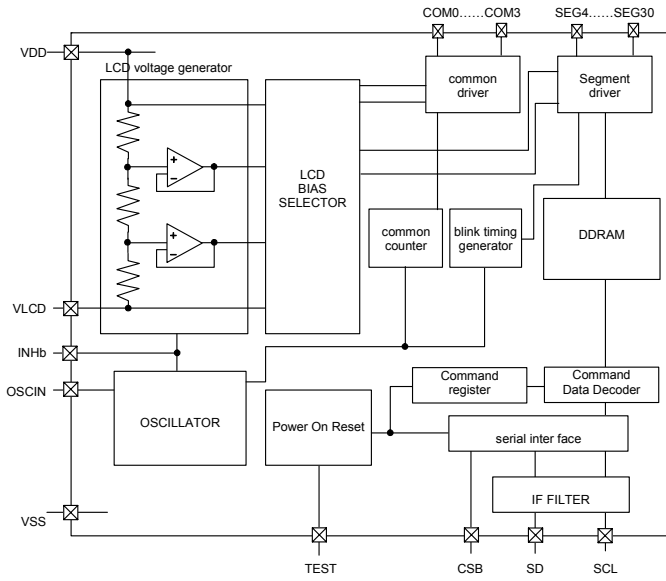

Fig.6 Block Diagram (BU9795AFV)

●Pin Arrangement

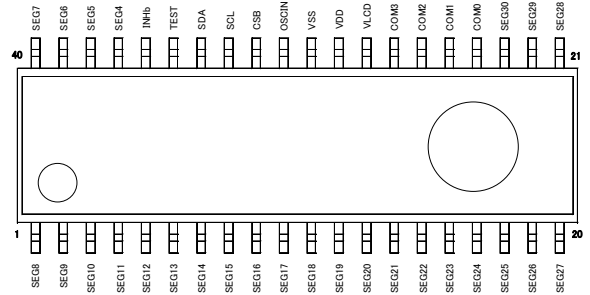

Fig.7 Pin Arrangement (BU9795AFV)

●Terminal Description

Terminal	Terminal No.	I/O	Function
INHb	36	I	Input terminal for turn off display H: turn on display L: turn off display
TEST	35	I	Test input (ROHM use only) Must be connect to VSS
OSCIN	31	I	External clock input Ex clock and Int clock can be changed by command. Must be connect to VSS when use internal oscillation circuit.
SD	34	I	serial data input
SCL	33	I	serial data transfer clock
CSB	32	I	Chip select : "L" active
VSS	30	-	GND
VDD	29	-	Power supply
VLCD	28	-	Power supply for LCD driving
SEG4-30	1-23, 37-40	O	SEGMENT output for LCD driving
COM0-3	24-27	O	COMMON output for LCD driving

<BU9795AGUW>
●Block Diagram

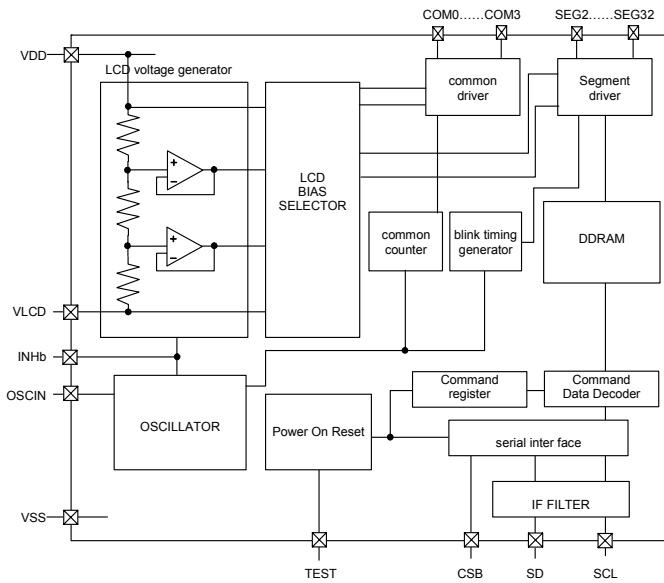

Fig.8 Block Diagram (BU9795AGUW)

●Pin Arrangement

	1	2	3	4	5	6	7
G	(NC)	SEG13	SEG15	SEG18	SEG20	SEG22	(NC)
F	SEG11	SEG12	SEG16	SEG17	SEG21	SEG23	SEG24
E	SEG9	SEG10	SEG14	SEG19	SEG25	SEG27	SEG26
D	SEG7	SEG6	SEG8	SEG5	SEG30	SEG28	SEG29
C	SEG4	SEG3	SEG2	CSB	COM3	SEG32	SEG31
B	X	INHb	SD	VSS	VDD	COM1	COM0
A	(NC)	TEST2	SCL	OSCIN	VLCD	COM2	(NC)

Fig.9 Pin Arrangement (BU9795AGUW)

●Terminal Description

Terminal	I/O	Function
INHb	I	Input terminal for turn off display H: turn on display L: turn off display
TEST	I	Test input (ROHM use only) Must be connect to VSS
OSCIN	I	External clock input Ex clock and Int clock can be changed by command. Must be connect to VSS when use internal oscillation circuit.
SD	I	serial data input
SCL	I	serial data transfer clock
CSB	I	Chip select : "L" active
VSS	-	GND
VDD	-	Power supply
VLCD	-	Power supply for LCD driving
SEG2-32	O	SEGMENT output for LCD driving
COM0-3	O	COMMON output for LCD driving

(Caution) About terminal number, please refer to above pin arrangement

<BU9794AKV>
●Block Diagram

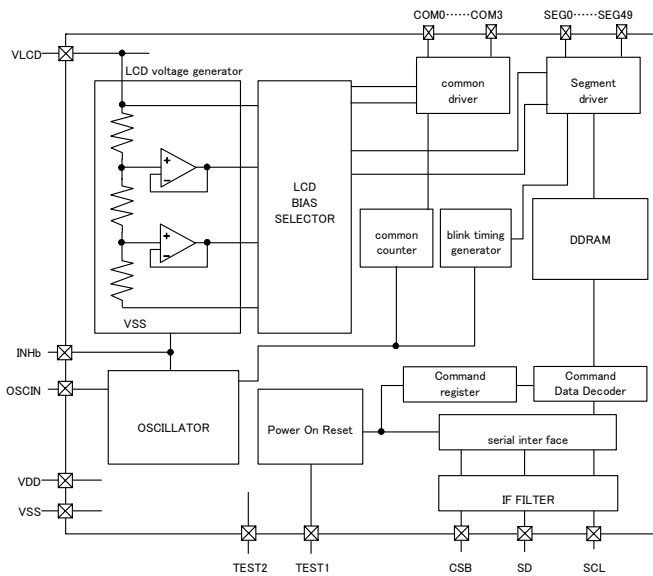

Fig.10 Block Diagram (BU9794AKV)

●Pin Arrangement

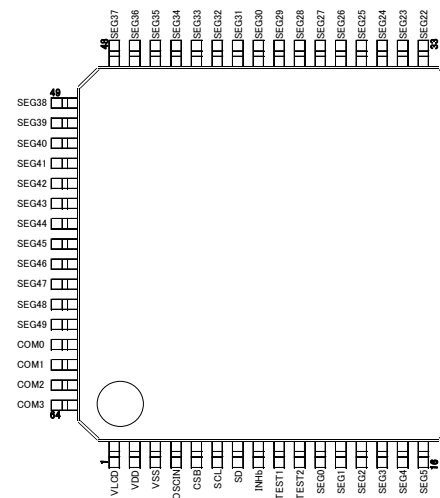

Fig.11 Pin Arrangement (BU9794AKV)

●Terminal Description

Terminal	Terminal No.	I/O	Function
INHb	8	I	Input terminal for turn off display H: turn on display, L: turn off display
TEST1	9	I	Test input (ROHM use only) Must be connect to VSS
TEST2	10	I	Test input (ROHM use only) Must be connect to VSS
OSCIN	4	I	External clock input Ex clock and Int clock can be changed by command. Must be connect to VSS when use internal oscillation circuit.
SD	7	I	serial data input
SCL	6	I	serial data transfer clock
CSB	5	I	Chip select : "L" active
VSS	3	-	GND
VDD	2	-	Power supply
VLCD	1	-	Power supply for LCD driving
SEG0-49	11-60	O	SEGMENT output for LCD driving
COM0-3	61-64	O	COMMON output for LCD driving

<BU97950FUV>
●Block Diagram

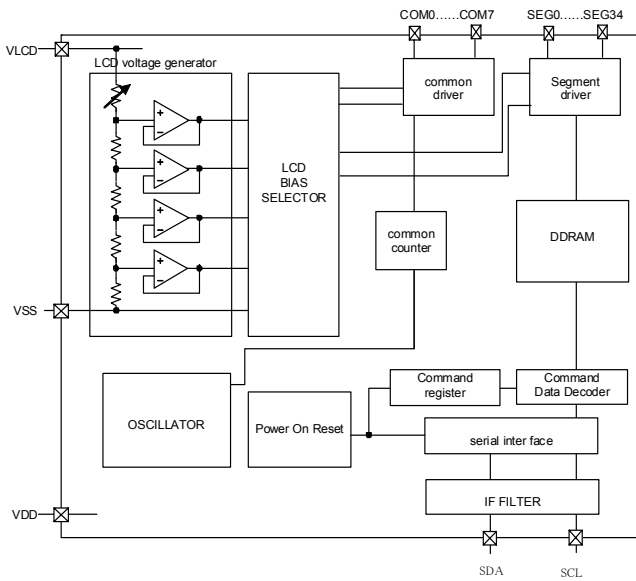

Fig.12 Block Diagram (BU97950FUV)

●Pin Arrangement

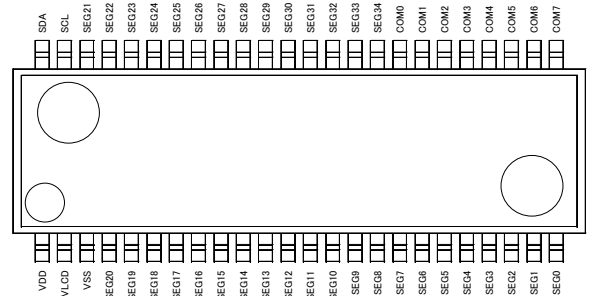

Fig.13 Pin Arrangement (BU97950FUV)

●Terminal Description

Terminal	Terminal No.	I/O	Function
SDA	48	I/O	serial data input register read data output port
SCL	47	I	serial data transfer clock
VSS	3	-	GND
VDD	1	-	Power supply
VLCD	2	-	Power supply for LCD driving
SEG0-35	4-24 33-46	O	SEGMENT output for LCD driving
COM0-7	25-32	O	COMMON output for LCD driving

●IO Equivalent Circuit

<BU9795AKV/FV/GUW>

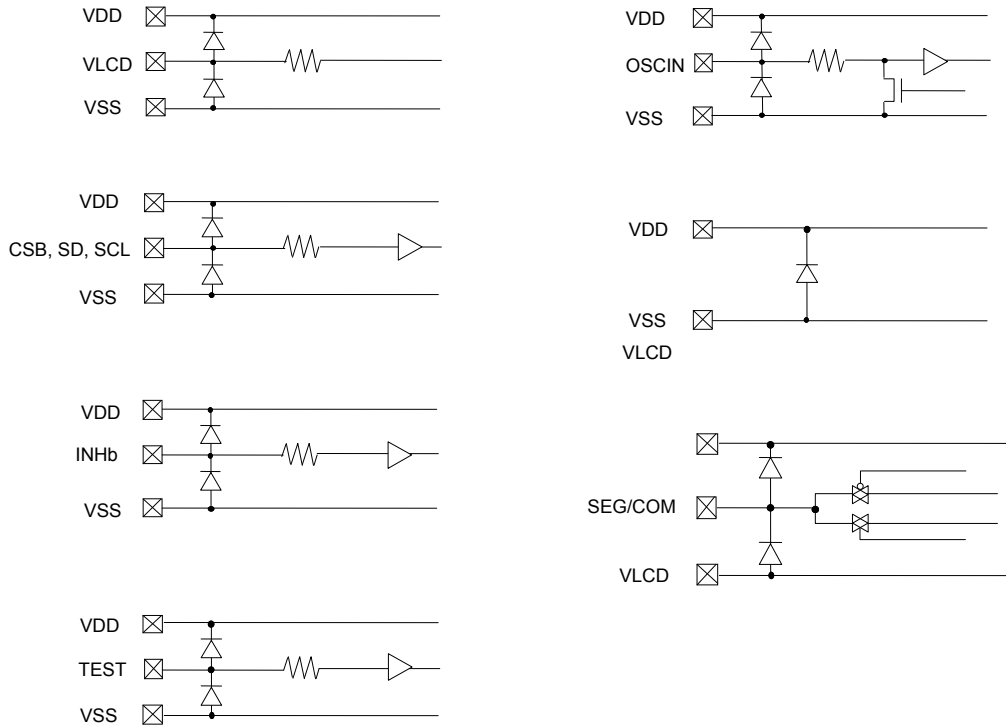

Fig.14 I/O equivalent circuit (BU9795AKV/FV/GUW)

<BU9794AKV>

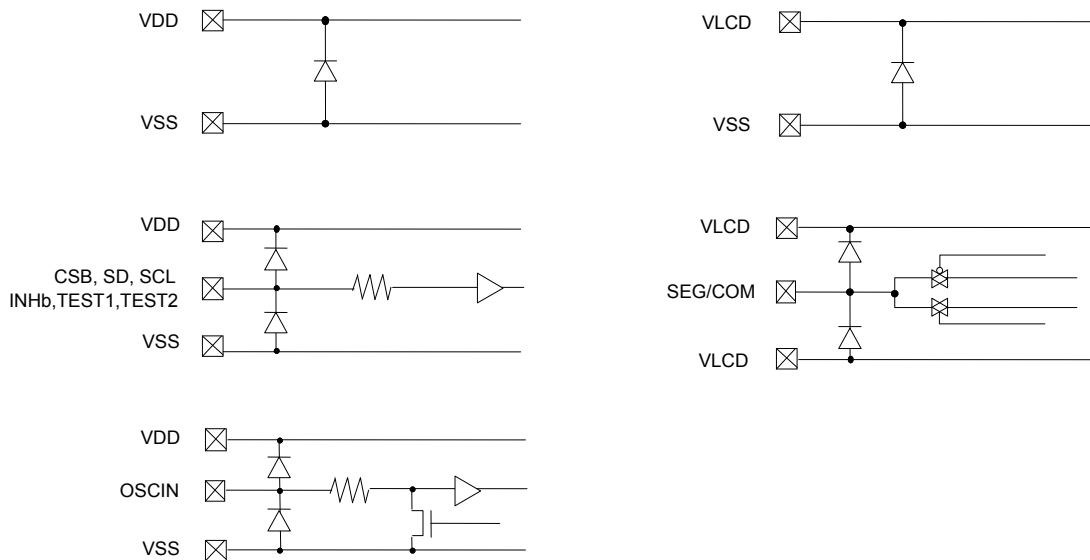

Fig.15 I/O equivalent circuit (BU9794AKV)

<BU97950FUV>

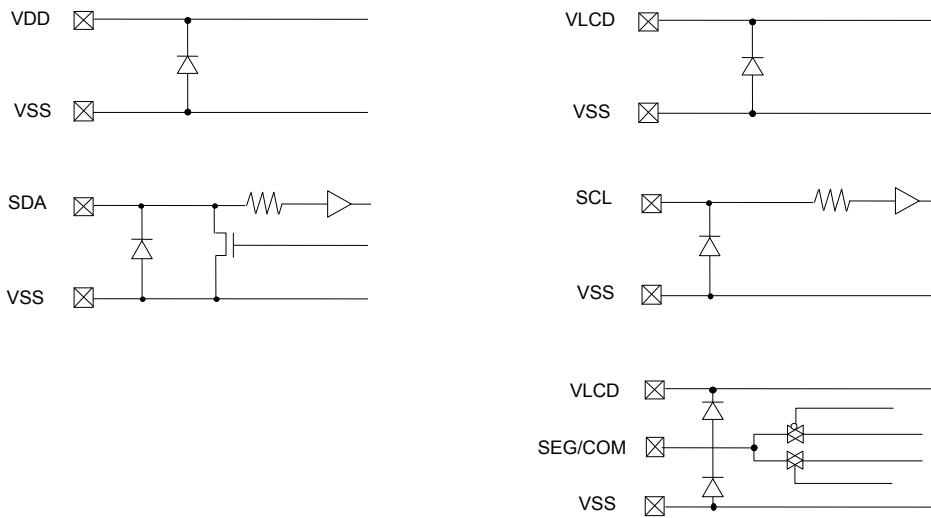
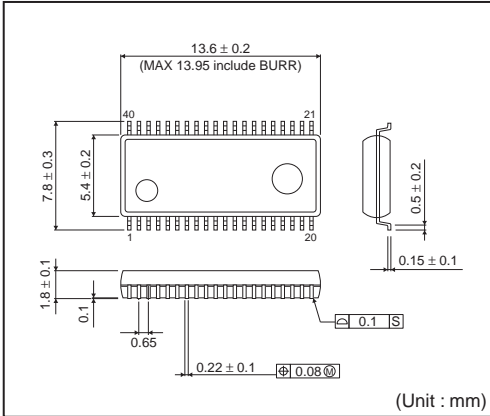

Fig.16 I/O equivalent circuit (BU97950FUV)

●Ordering part number

B	U	9	7	9	5	A	G	U	W	-	E	2
Part No.		Part No. BU9795A BU9794A BU97950					Package FV : SSOP-B40 GUW: VBGA048W040 KV : VQFP48C KV : VQFP64 FUV : TSSOP-C48V			Packaging and forming specification E2: Embossed tape and reel		

SSOP-B40



<Tape and Reel information>

Tape	Embossed carrier tape
Quantity	2000pcs
Direction of feed	E2 (The direction is the 1pin of product is at the upper left when you hold reel on the left hand and you pull out the tape on the right hand)

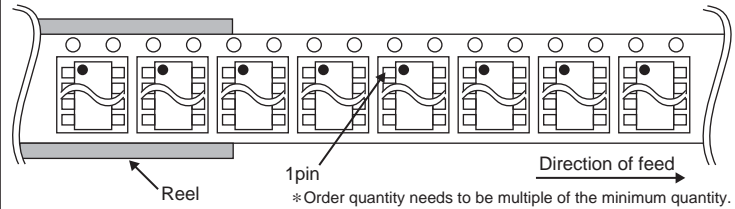

VBGA048W040

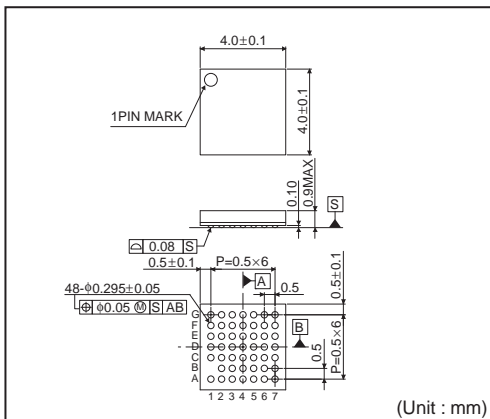

<Tape and Reel information>

Tape	Embossed carrier tape (with dry pack)
Quantity	2500pcs
Direction of feed	E2 (The direction is the 1pin of product is at the upper left when you hold reel on the left hand and you pull out the tape on the right hand)

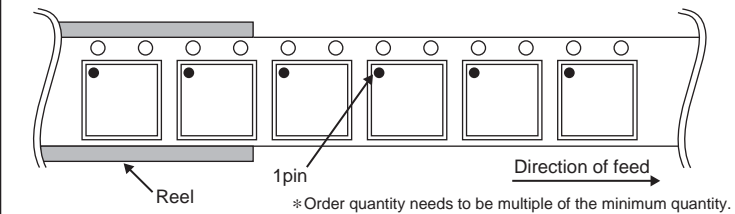

TSSOP-C48V

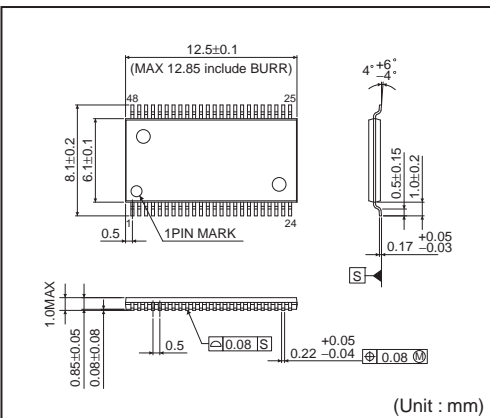

<Tape and Reel information>

Tape	Embossed carrier tape (with dry pack)
Quantity	2000pcs
Direction of feed	E2 (The direction is the 1pin of product is at the upper left when you hold reel on the left hand and you pull out the tape on the right hand)

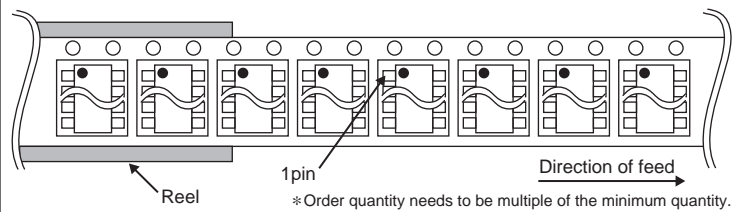

VQFP48C

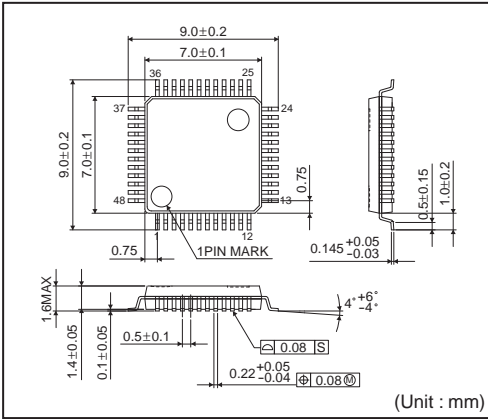

<Tape and Reel information>

Tape	Embossed carrier tape
Quantity	1500pcs
Direction of feed	E2 (The direction is the 1pin of product is at the upper left when you hold) reel on the left hand and you pull out the tape on the right hand)

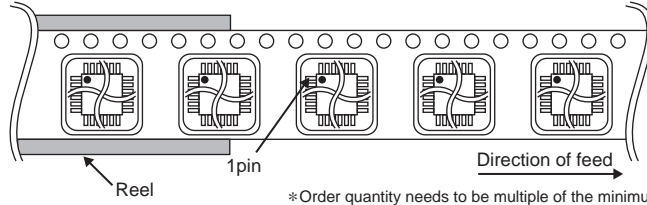

VQFP64

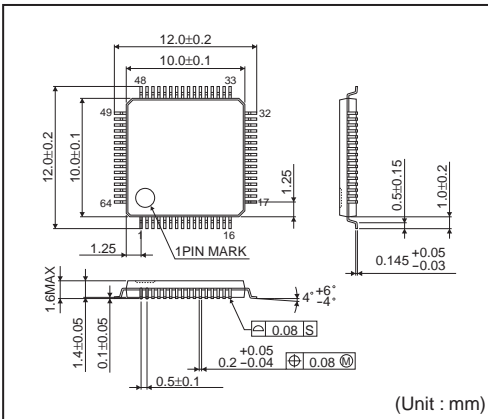

<Tape and Reel information>

Tape	Embossed carrier tape (with dry pack)
Quantity	1000pcs
Direction of feed	E2 (The direction is the 1pin of product is at the upper left when you hold) reel on the left hand and you pull out the tape on the right hand)

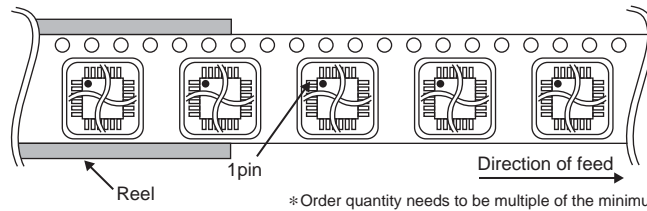

Notes

No copying or reproduction of this document, in part or in whole, is permitted without the consent of ROHM Co.,Ltd.

The content specified herein is subject to change for improvement without notice.

The content specified herein is for the purpose of introducing ROHM's products (hereinafter "Products"). If you wish to use any such Product, please be sure to refer to the specifications, which can be obtained from ROHM upon request.

Examples of application circuits, circuit constants and any other information contained herein illustrate the standard usage and operations of the Products. The peripheral conditions must be taken into account when designing circuits for mass production.

Great care was taken in ensuring the accuracy of the information specified in this document. However, should you incur any damage arising from any inaccuracy or misprint of such information, ROHM shall bear no responsibility for such damage.

The technical information specified herein is intended only to show the typical functions of and examples of application circuits for the Products. ROHM does not grant you, explicitly or implicitly, any license to use or exercise intellectual property or other rights held by ROHM and other parties. ROHM shall bear no responsibility whatsoever for any dispute arising from the use of such technical information.

The Products specified in this document are intended to be used with general-use electronic equipment or devices (such as audio visual equipment, office-automation equipment, communication devices, electronic appliances and amusement devices).

The Products specified in this document are not designed to be radiation tolerant.

While ROHM always makes efforts to enhance the quality and reliability of its Products, a Product may fail or malfunction for a variety of reasons.

Please be sure to implement in your equipment using the Products safety measures to guard against the possibility of physical injury, fire or any other damage caused in the event of the failure of any Product, such as derating, redundancy, fire control and fail-safe designs. ROHM shall bear no responsibility whatsoever for your use of any Product outside of the prescribed scope or not in accordance with the instruction manual.

The Products are not designed or manufactured to be used with any equipment, device or system which requires an extremely high level of reliability the failure or malfunction of which may result in a direct threat to human life or create a risk of human injury (such as a medical instrument, transportation equipment, aerospace machinery, nuclear-reactor controller, fuel-controller or other safety device). ROHM shall bear no responsibility in any way for use of any of the Products for the above special purposes. If a Product is intended to be used for any such special purpose, please contact a ROHM sales representative before purchasing.

If you intend to export or ship overseas any Product or technology specified herein that may be controlled under the Foreign Exchange and the Foreign Trade Law, you will be required to obtain a license or permit under the Law.



Thank you for your accessing to ROHM product informations.
More detail product informations and catalogs are available, please contact us.

ROHM Customer Support System

<http://www.rohm.com/contact/>

Данный компонент на территории Российской Федерации

Вы можете приобрести в компании MosChip.

Для оперативного оформления запроса Вам необходимо перейти по данной ссылке:

<http://moschip.ru/get-element>

Вы можете разместить у нас заказ для любого Вашего проекта, будь то серийное производство или разработка единичного прибора.

В нашем ассортименте представлены ведущие мировые производители активных и пассивных электронных компонентов.

Нашей специализацией является поставка электронной компонентной базы двойного назначения, продукции таких производителей как XILINX, Intel (ex.ALTERA), Vicor, Microchip, Texas Instruments, Analog Devices, Mini-Circuits, Amphenol, Glenair.

Сотрудничество с глобальными дистрибьюторами электронных компонентов, предоставляет возможность заказывать и получать с международных складов практически любой перечень компонентов в оптимальные для Вас сроки.

На всех этапах разработки и производства наши партнеры могут получить квалифицированную поддержку опытных инженеров.

Система менеджмента качества компании отвечает требованиям в соответствии с ГОСТ Р ИСО 9001, ГОСТ РВ 0015-002 и ЭС РД 009

Офис по работе с юридическими лицами:

105318, г.Москва, ул.Щербаковская д.3, офис 1107, 1118, ДЦ «Щербаковский»

Телефон: +7 495 668-12-70 (многоканальный)

Факс: +7 495 668-12-70 (доб.304)

E-mail: info@moschip.ru

Skype отдела продаж:

moschip.ru

moschip.ru_4

moschip.ru_6

moschip.ru_9