

DWG. NO.
SA25594

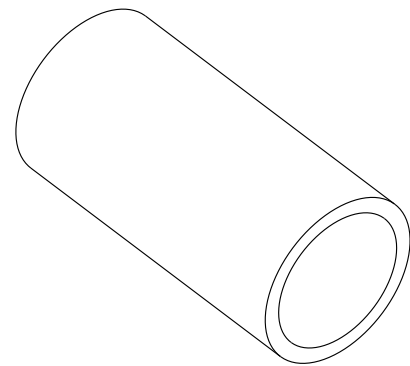
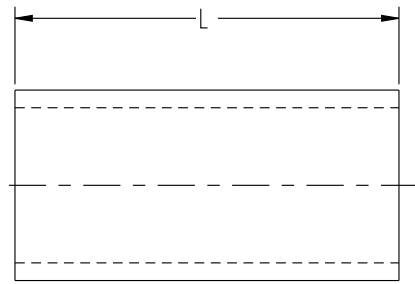
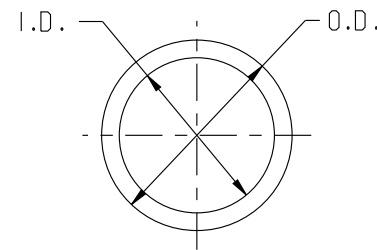

SCALE 8:1

NOTE:

1. MATERIALS: AS NOTED.
2. PLATING: TIN PLATED.
3. SURFACE TREATMENT : IRIDITE OVER CADMIUM PLATE.

* THESE SIZES NOT IRIDITED.

THIS DRAWING IS A CONTROLLED DOCUMENT FOR SOURIAU USA, INC. IT IS SUBJECT TO CHANGE WITHOUT NOTIFICATION. CONTACT THE DOCUMENT CONTROL CENTER FOR THE LATEST REVISION.

THE INFORMATION CONTAINED IN THIS DRAWING IS CONFIDENTIAL AND MAY NOT BE DISCLOSED WITHOUT WRITTEN CONSENT FROM SOURIAU USA, INC.

| OUTER HYRING | | | | | | | | |
|--------------|--------|---------------------|------|--------------------------------|------------------|-------------------------|--------------------|------------------|
| L=.25 | | DIAMETER (IN INCH.) | | INSTALLATION TOOLS | | | | |
| CAT. NO. | COLOR | I.D. | O.D. | RATCHET HYTOOLS | | HYTOOLS | HYPRESSES | |
| | | | | MR8PV TYPE INCLUDES DIE | M8ND DIE SET NO. | Y10R Y10C-1 DIE SET NO. | Y10NCP DIE SET NO. | Y8ND DIE SET NO. |
| YOC 70 | *TIN | .101 | .124 | MR8PV-14S | | R7VST | | |
| YOC 80 | BLUE | .125 | .156 | MR8PV-S | N8VST | R8VST | | N8VST |
| YOC 90 | PURPLE | .149 | .179 | MR8PV-S, MR8PV-1S | N10VST | R14VST-5 | | N10VST |
| YOC 100 | YELLOW | .156 | .196 | MR8PV-S, MR8PV-1S | N10VST | R14VST-5 | | N10VST |
| YOC 110 | BLUE | .180 | .204 | MR8PV-S, MR8PV-1S | N10VST | R14VST-5 | | N10VST |
| YOC 112 | BLUE | .175 | .215 | MR8PV-S, MR8PV-1S | N12VST | R14VST-5 | | N12VST |
| YOC 120 | ORANGE | .187 | .227 | MR8PV-S, MR8PV-1S | N12VST | R14VST-5 | | N12VST |
| YOC 128 | *TIN | .199 | .235 | MR8PV-S, MR8PV-1S | N12VST | R14VST-5 | | N12VST |
| YOC 130 | YELLOW | .207 | .243 | MR8PV-S, MR8PV-1S MR8PV-10S | N12VST N13VST | R14VST-5 R14VST-3 | | N12VST N13VST |
| YOC 140 | GREEN | .219 | .250 | MR8PV-1S MR8PV-11S | N14VST | R14VST-5 | | N14VST |
| YOC 150 | ORANGE | .235 | .266 | MR8PV-2 | N16VT | R18VT-3 | | N16VT |
| YOC 160 | YELLOW | .261 | .297 | MR8PV-2 | N16VT | R18VT-3 | | N16VT |
| YOC 180 | PURPLE | .281 | .331 | MR8PV-2 | | R18VT-3 | | |
| YOC 190 | GREEN | .300 | .335 | MR8PV-2 | | R18VT-3 | | |
| YOC 200 | YELLOW | .312 | .362 | MR8PV-3 | | R20VT | | |
| YOC 220 | ORANGE | .344 | .394 | MR8PV-4 MR8PV-11S | | R22VT | | |
| YOC 240 | BLUE | .375 | .406 | MR8PV-7 | | R24VT | | |
| YOC 250 | RED | .405 | .453 | MR8PV-6 | | R25VT | | |
| YOC 320G1 | PURPLE | .500 | .550 | | | R29VT | | |
| YOC 371G1 | *TIN | .580 | .620 | | | R32VT | | |
| YOC 370 | *TIN | .705 | .755 | MD5-36 | | | | |

| INNER HYRING | | | |
|--------------|--------|---------------------|------|
| L=.31 | | DIAMETER (IN INCH.) | |
| CAT. NO. | COLOR | I.D. | O.D. |
| YIC046 | *TIN | .046 | .070 |
| YIC058 | YELLOW | .058 | .083 |
| YIC063 | RED | .063 | .088 |
| YIC071 | GREEN | .071 | .096 |
| YIC080 | BLUE | .080 | .104 |
| YIC090 | ORANGE | .090 | .114 |
| YIC101 | YELLOW | .101 | .124 |
| YIC109 | RED | .109 | .131 |
| YIC115 | *TIN | .115 | .146 |
| YIC124 | GREEN | .124 | .145 |
| YIC125 | YELLOW | .125 | .156 |
| YIC134 | ORANGE | .134 | .156 |
| YIC150 | BLUE | .150 | .181 |
| YIC156 | RED | .166 | .191 |
| YIC180 | GREEN | .180 | .204 |
| YIC194 | BLUE | .194 | .255 |
| YIC219 | *TIN | .219 | .243 |
| YIC261 | BLUE | .261 | .297 |
| YIC297 | RED | .297 | .337 |
| YIC375G1 | *TIN | .375 | .423 |
| YIC472G1 | *TIN | .472 | .516 |
| YIC495G1 | *TIN | .495 | .535 |
| YIC340 | *TIN | .340 | .390 |

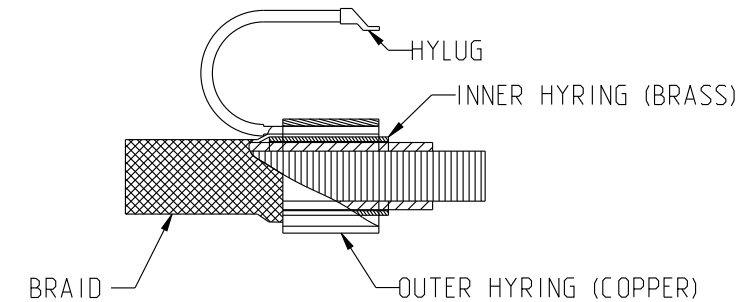

PROPER SELECTION OF HYRINGS:

OUTER FERRULES MAY BE USED IN COMBINATION WITH ANY INNER FERRULES, DEPENDING ON THE SIZE OF THE CONDUCTOR, THE THICKNESS OF THE SHIELD AND THE SIZE OF THE GROUND TAP. HOWEVER, DUE TO VARIATION IN INSULATION DIAMETER AND BRAID CONSTRUCTION, THE RECOMMENDED BASIS FOR SIZE SELECTION FOR SHIELDED CABLE IS A FACTORY-INSTALLED, SAMPLE CONNECTION MADE ON ACTUAL WIRE TO BE USED. IF IT IS NOT CONVENIENT TO FORWARD WIRE SAMPLES, SIZES CAN BE DETERMINED AS FOLLOWS:

DETERMINE O.D. OF INNER INSULATION. SELECT INNER HYRING FROM CHART ABOVE HAVING I.D. A MINIMUM OF .005 GREATER THAN THIS DIAMETER. TO THE O.D. OF THIS FERRULE ADD .025 (FOR SINGLE BRAID) PLUS .040 FOR WIRE TAP (UPTO #18), IF USED, AND SELECT OUTER FERRULE HAVING I.D. ATLEAST EQUAL TO THIS FIGURE. THE PROPER CRIMPING TOOL FOR EACH OUTER HYRING IS LISTED ON TABLE.

SUPERSEDES: SA-25594-16

| | | | |
|-----|-----------------------|-----------------|-----------------|
| W | REVISED PER ECN 11866 | CJM 12-12-12 | SDH 12-12-12 |
| REV | DESCRIPTION | BY DATE | CHKD DATE |

DRAWING TITLE
COLORED FERRULES

CAT NO. **YIC & YOC _____ (SEE TABLE)**

CAGE NO: 09922 SIZE: B

CUSTOMER

INTERPRET THIS DRAWING IN ACCORDANCE WITH ASME Y14.5M-1994.



SOURIAU
Connection Technology

www.souriau.com

APPROVAL

| | | |
|----------------|-----|----------|
| DRAWN: | NVM | 11-14-11 |
| CHKD : | SDH | 11-14-11 |
| DSGN : | XXX | mm-dd-yy |
| MFG : | DH | 11-14-11 |
| QC : | BB | 11-14-11 |
| DRAWING SCALE: | | 8:1 |
| DRAWING NO. | | REV |
| SA25594 | | W |
| 1 OF 1 | | |

LINEAR MEASURE: INCH INCH [mm]

THIRD ANGLE PROJECTION

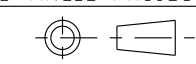

TOLERANCES UNLESS OTHERWISE SPECIFIED

| No. OF PLACES | INCH [mm] |
|---------------|-------------|
| ONE PLACE | ±.1 [±3] |
| TWO PLACES | ±0.02 [±.5] |
| THREE PLACES | ±0.005 |

ANGLES ±1°

B

A

Данный компонент на территории Российской Федерации

Вы можете приобрести в компании MosChip.

Для оперативного оформления запроса Вам необходимо перейти по данной ссылке:

<http://moschip.ru/get-element>

Вы можете разместить у нас заказ для любого Вашего проекта, будь то серийное производство или разработка единичного прибора.

В нашем ассортименте представлены ведущие мировые производители активных и пассивных электронных компонентов.

Нашей специализацией является поставка электронной компонентной базы двойного назначения, продукции таких производителей как XILINX, Intel (ex.ALTERA), Vicor, Microchip, Texas Instruments, Analog Devices, Mini-Circuits, Amphenol, Glenair.

Сотрудничество с глобальными дистрибьюторами электронных компонентов, предоставляет возможность заказывать и получать с международных складов практически любой перечень компонентов в оптимальные для Вас сроки.

На всех этапах разработки и производства наши партнеры могут получить квалифицированную поддержку опытных инженеров.

Система менеджмента качества компании отвечает требованиям в соответствии с ГОСТ Р ИСО 9001, ГОСТ РВ 0015-002 и ЭС РД 009

Офис по работе с юридическими лицами:

105318, г.Москва, ул.Щербаковская д.3, офис 1107, 1118, ДЦ «Щербаковский»

Телефон: +7 495 668-12-70 (многоканальный)

Факс: +7 495 668-12-70 (доб.304)

E-mail: info@moschip.ru

Skype отдела продаж:

moschip.ru

moschip.ru_4

moschip.ru_6

moschip.ru_9