



PRODUCT OVERVIEW

The D1U5CS-H-2825 is a 2825 Watt, power-factor-corrected (PFC) front-end power supply for redundant systems. The main output is 12V and the standby output is 5V. Packaged in 1U low profile, it is designed to deliver reliable bulk power to servers, workstations, storage systems or any 12V distributed power architecture system requiring high power density. The highly efficient electrical and thermal design with internal cooling fans supports reliable operating conditions. The D1U5CS-H-2825 is designed to autorecover from over-temperature faults. Status information is provided with front panel LEDs, logic signals and I²C management interface.

ORDERING GUIDE

Model Number	Power Output	Main Output	Standby Output	Airflow	Connector
D1U5CS-H-2825-12-HA4C	2825W	12V	5V	Back to front, variable	AC front

FEATURES

- 2825W (220Vac) Output power
- Certified to Climate Savers Computing InitiativeSM80 PLUS[®] Gold efficiency
- 12V Main output, 5V standby output
- 1U sized; dimensions 5.1"x14.4"x1.61"
- 23.9 Watts per cubic inch density
- N+1 redundancy capable, including hot plugging (up to 3 in parallel)
- Active current sharing on main output, ORing FET
- Overvoltage, Overcurrent, Overtemperature protection
- Internal cooling fans (variable speed)
- I²C Bus Interface with status indicators
- RoHS compliant

INPUT CHARACTERISTICS

Parameter	Conditions	Min.	Typ.	Max.	Units
Voltage Operating Range		180		264	Vac
Frequency		47	60	63	Hz
Maximum Current	230Vac			16	Arms
Inrush Current				90	Apk
Power Factor	At 230Vac, full load	0.95			
	20% load		88.31		
	50% load		92.63		
Efficiency (230Vac) excludes fan load	100% load		92.05		
					%

OUTPUT VOLTAGE CHARACTERISTICS

Output Voltage	Parameter	Conditions	Min.	Typ.	Max.	Units
12V	Voltage Set Point Accuracy			12.12		Vdc
	Line and Load Regulation		11.75		12.48	
	Ripple Voltage & Noise ¹	20MHz Bandwidth			120	mV p-p
	Output Current		0		233	A
	Load Capacitance		0		2200	μF
5Vsb	Voltage Set Point Accuracy			5.0		Vdc
	Line and Load Regulation		4.85		5.15	
	Ripple Voltage & Noise ¹	20MHz Bandwidth			50	mV p-p
	Output Current		0		4	A
	Load Capacitance		0		200	μF

OUTPUT CHARACTERISTICS

Parameter	Conditions	Min.	Typ.	Max.	Units
Startup Time	AC ramp up		1.5		s
	PS_On activated		150		ms
Transient Response	12V Ramp 1A/μs load capacitance is 2200μF			±600	mV
	5Vsb Ramp 1A/μs load capacitance is 200μF			±250	
Current sharing accuracy (up to 3 in parallel)	At 100% load			±10	%
Holdup Time		12			ms
Remote Sense	20% load	88.3	120		mV

¹ Ripple and noise are measured with 0.1 μF of ceramic capacitance and 10 μF of tantalum capacitance on each of the power supply outputs. A short coaxial cable with 50ohm scope termination is used.



ENVIRONMENTAL CHARACTERISTICS					
Parameter	Conditions	Min.	Typ.	Max.	Units
Storage Temperature Range	Non-condensing	-40		70	°C
Operating Temperature Range		0		50	
Operating Humidity	Non-condensing	10		90	%
Storage Humidity		5		90	
Shock	30G non operating				
Sinusoidal Vibration	0.5G, 5 – 500 Hz				
MTBF	Calculated per Telecordia SR322M1C2				hrs
	Ta = 30°C	716,317			
	Ta = 40°C	484,059			
Acoustic	ISO 7779-1999				
Safety Approvals:	c-CSA-US (CSA 60950-1-03/UL 60950-1, Second Edition TUV EN 60950-1:2006+All EN6950-1:2006+A11 CB Report IEC 60950-1:2005(2nd ed.,) EN60950-1:2006+All				
Input Fuse	Power Supply has internal 20A/250V fast blow fuse on the AC line input				
Material Flammability	UL 94V-0				
Switching Frequency	TBD				
Weight	5.92lbs (2.691kg)				

PROTECTION CHARACTERISTICS						
Output Voltage	Parameter	Conditions	Min.	Typ.	Max.	Units
12V	Overtemperature	Autorestart	55		65	°C
	Overvoltage	Latching	13.3		14.4	V
	Overcurrent	Latching	243		255	A
5Vsb	Overvoltage	Latching; requires AC recycling	5.6		6	V
	Overcurrent	Autorecovering	5		7	A

Note: The main output is able to be re-enabled after OCP and OVP event by cycling PS_ON/L pin from low to high to low.

ISOLATION CHARACTERISTICS					
Parameter	Conditions	Min.	Typ.	Max.	Units
Insulation Safety Rating / Test Voltage	Input to Output - Reinforced	3000			Vrms
	Input to Chassis - Basic	1500			Vrms
Material Flammability	UL 94V-0				

CONTROL SIGNALS		
Status	Conditions	Description
LED	Off	No AC input to all PS
	Yellow	Power Supply Failure
	Flashing Green	Main Output Disabled
	Green	Power Supply Good
I ² C Registers	Status	PS-ON, PGOOD, ACOK, PS_BAD, FANFAIL, OT Warning & shutdown, AC Range
	Output Fault	12V OV, 12V UV, 12V OC, Vsb Fail, Fan1 Warn, Fan2 Warn
	12V Output	10 bit scaled output voltage
	12V	10 bit scaled output current
	Fan1 Monitor	Fan speed (RPM)
	Fan2 Monitor	Fan speed (RPM)
	Standby Output	10 bit scaled output voltage
	Standby Output	10 bit scaled output current
	Ambient temp	10 bit ambient temperature reading
	HS1 temp	10 bit heatsink 1 temperature reading
	HS2 temp	10 bit heatsink 2 temperature reading
	VAC	10 bit scaled input voltage
	IAC	10 bit scaled input current

EMISSIONS AND IMMUNITY

Characteristic	Description	Criteria
Harmonics	IEC/EN 61000-3-2	
Voltage Fluctuation and Flicker	IEC/EN 61000-3-3	
Emission Conducted	FCC 47 CFR Parts 15/CISPR 22/EN55022	Class A, 4dB margin
Emission Radiated	FCC 47 CFR Parts 15/CISPR 22/EN55022	Class A
ESD	IEC/EN 61000-4-2	4kV contact discharge
		8kV operational air discharge
		15kV non-operational air discharge
Electromagnetic Field	IEC/EN 61000-4-3	
Electrical Fast Transients/Burst	IEC/EN 61000-4-4	
Surge	IEC/EN 61000-4-5	1kV/2kV, Performance Criteria B
RF Conducted Immunity	IEC/EN 61000-4-6	3 Vac, 80% AM, 1kHz, Performance Criteria A
Magnetic Immunity	IEC/EN 61000-4-8	3 A/m
Voltage dips, interruptions	IEC/EN 61000-4-11	

OUTPUT CONNECTOR AND SIGNAL SPECIFICATION

DC and Signal Connector: FCI PowerBlade # 51939-486LF

P1	P2	P3	P4	P5	P6	P7	P8	P9	P10	P11	P12	x1	x2	x3	x4	x5	x6	
V _{OUT}	V _{OUT}	V _{OUT}	V _{RTN}	V _{RTN}	V _{RTN}	V _{RTN}	V _{RTN}	V _{RTN}	V _{OUT}	V _{OUT}	V _{OUT}	AC_OK/H	PW_OK/L	V _{SB} Return	V _{SB} Return	V _{SB} +OUT	V _{SB} +OUT	D
												SPARE	SMB/Alert	V _{SB} Return	V _{SB} Return	V _{SB} +OUT	V _{SB} +OUT	C
												I_SHARE	I ² C ADRO	I ² C ADR1	I ² C ADR2	PS_KILL	PS_Present	B
												SENSE +	SENSE -	I ² C DATA	I ² C CLOCK	SPARE	PS_ON/L	A

mate-last pins

Pin Assignment	Signal Name	Description	High Level Low Level	I Max
P1, P2, P3, P10, P11, P12	V _{OUT}	Main output voltage		
P4, P5, P6, P7, P8, P9	V _{RTN}	Main output voltage, return		
A1	Sense +	V _{OUT} remote sense, positive node input, connected to the +ve load point		
A2	Sense -	V _{OUT} remote sense, negative node input, connected to the -ve load point		
C5, C6, D5, D6	V _{SB}	Standby voltage output		
C3, C4, D3, D4	V _{SB} Return	Standby voltage, return, tied internally to Output Return		
B1	I_Share	Active load sharing bus	0 – 8V	-4 mA / +5 mA
D1	AC_OK/H	Input AC Voltage “OK” signal output (open drain with internal pull up of 10kΩ to V _{sb})	>2.5V <0.8V	-32mA
D2	PW_OK/L	Power OK signal output (open drain with internal pull up of 10kΩ to V _{sb})	>2.5V <0.8V	-32mA
C2	SMB/Alert	SMB/Alert signal output (open collector)		
B5	PS_Kill	Floating pin will turn off P/S (shorter pin, last-make and first-break contact for hot plugging). This signal overrides PS-On in disabling the Main Output	>2.1V (open) <0.8V (active, PS:On)	N/A
B6	PS_Present	Internally tied to V _{sb} return	0 V	
A6	PS_On/L	Internal 5.11KΩ pull-up to V _{sb} , (accepts open collector/drain drive). This signal to be pulled low to turn-on main output of power supply	>0.7 x V _{sb} <0.3 x V _{sb}	
A3	I ² C Data	I ² C serial data bus; internal 4.64kΩ pull-up to 3.3V	>0.7 x V _{sb} <0.3 x V _{sb}	
A4	I ² C Clock	I ² C serial clock bus; internal 4.64kΩ pull-up to 3.3V	>0.7 x V _{sb} <0.3 x V _{sb}	
B2	I ² C Adr0	Address input 0, internal 10kΩ pull-up to V _{sb}	>0.7 x V _{sb} <0.3 x V _{sb}	
B3	I ² C Adr1	Address input 1, internal 10kΩ pull-up to V _{sb}	>0.7 x V _{sb} <0.3 x V _{sb}	
B4	I ² C Adr2	Address input 2, internal 10kΩ pull-up to V _{sb}	>0.7 x V _{sb} <0.3 x V _{sb}	

DC OUTPUT RIGHT ANGLE CONNECTOR IN POWER SUPPLY (viewed from end of power supply)

PRODUCT NO.	ROWS	POWER												SIGNAL								
		E1	P1	P2	P3	P4	P5	P6	P7	P8	P9	P10	P11	P12	1	2	3	4	5	6	E2	
51939-486_	D C B A		PA	PA	PA	PA	PA	PA	PA	PA	PA	PA	PA	PA	UUUU	HH	TTTT	GG	SSSS	FF	RRRR	EE

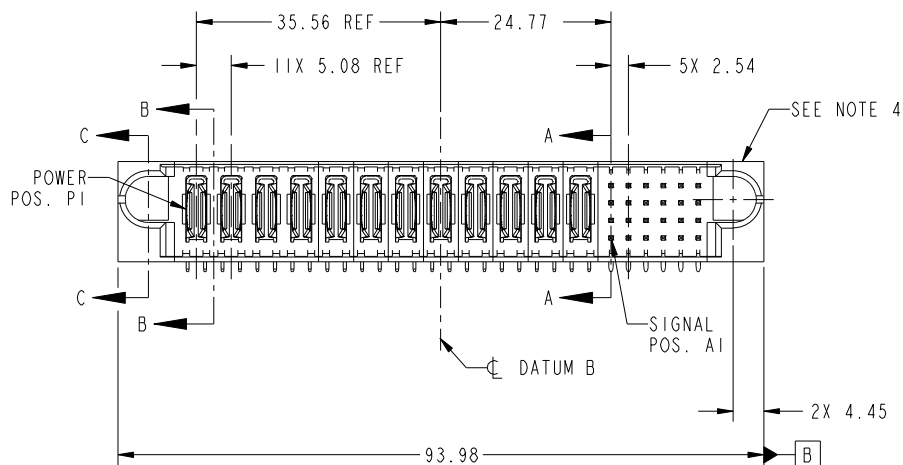

DC OUTPUT VERTICAL CONNECTOR MATE ON BACKPLANE (backplane view)

PRODUCT NO.	ROWS	SIGNAL						POWER													
		E2	6	5	4	3	2	1	P12	P11	P10	P9	P8	P7	P6	P5	P4	P3	P2	P1	E1
51940-323_	D C B A		F	F	F	F	F	F	PC	PC	PC	PC	PC	PC	PC	PC	PC	PC	PC	PC	

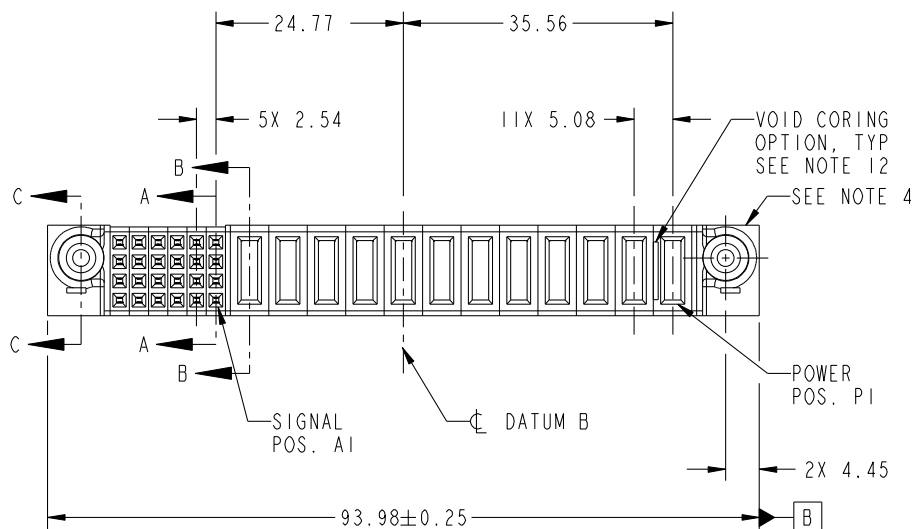

MECHANICAL DIMENSIONS

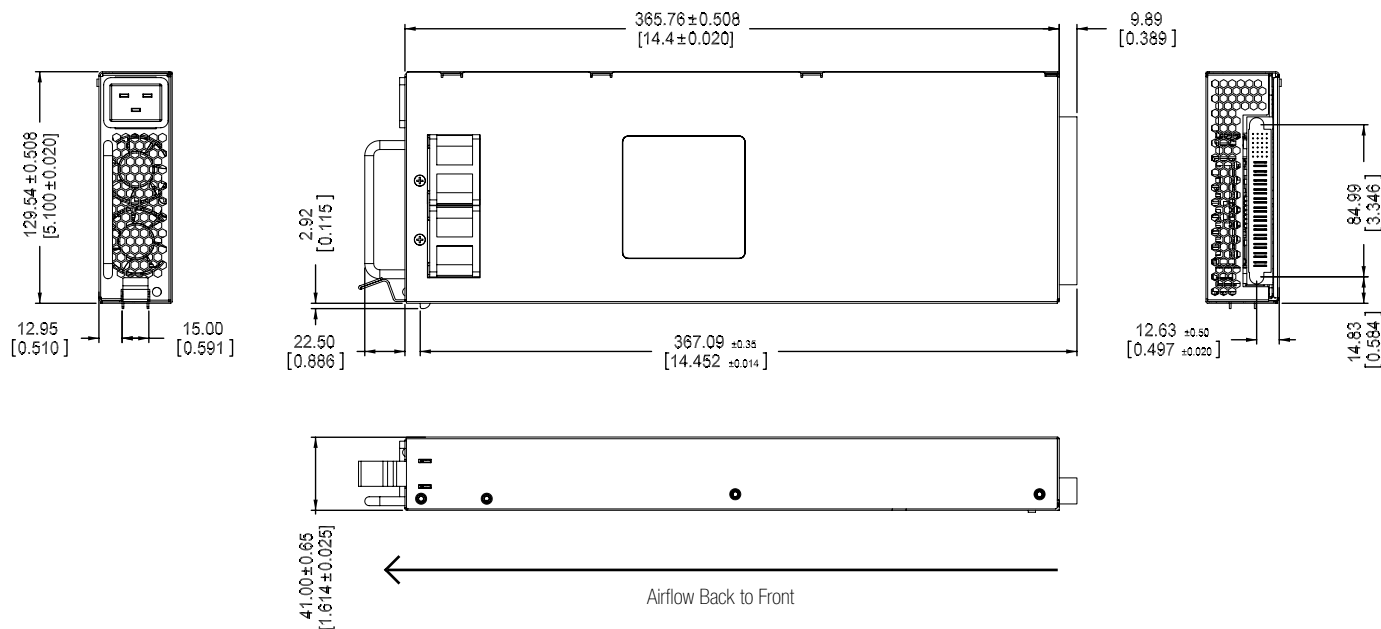

AC Input Connector: The AC input connector is standard IEC320 C20 (20A).

Dimensions: 5.1" x 14.4" x 1.61" [129.5mm x 367mm x 41mm]

D1U5CS MATING CONNECTORS

		12V D1U5CS mating connector			
		Press Fit		Solder ¹	
		Straight	Right Angle	Straight	Right Angle
MPS	TBD		4321-01576-0	TBD	TBD
FCI	51940-323		51915-132LF	TBD	TBD

¹ Solder connector recommended for board thickness of <0.090

OPTIONAL ACCESSORIES

Description	Part Number
12V D1U5CS Connector Card	D1U5CS-12-CONC

APPLICATION NOTES

Description	Application Note
12V D1U5CS Connector Card	ACAN-41
D1U5CS-H-2825-12-HxC Communication Protocol	ACAN-40
D1U EEPROM Specification	ACAN-37

Murata Power Solutions, Inc.
 11 Cabot Boulevard, Mansfield, MA 02048-1151 U.S.A.
 ISO 9001 and 14001 REGISTERED



This product is subject to the following [operating requirements](#) and the [Life and Safety Critical Application Sales Policy](#):
 Refer to: <http://www.murata-ps.com/requirements/>

Murata Power Solutions, Inc. makes no representation that the use of its products in the circuits described herein, or the use of other technical information contained herein, will not infringe upon existing or future patent rights. The descriptions contained herein do not imply the granting of licenses to make, use, or sell equipment constructed in accordance therewith. Specifications are subject to change without notice. © 2012 Murata Power Solutions, Inc.

Данный компонент на территории Российской Федерации

Вы можете приобрести в компании MosChip.

Для оперативного оформления запроса Вам необходимо перейти по данной ссылке:

<http://moschip.ru/get-element>

Вы можете разместить у нас заказ для любого Вашего проекта, будь то серийное производство или разработка единичного прибора.

В нашем ассортименте представлены ведущие мировые производители активных и пассивных электронных компонентов.

Нашей специализацией является поставка электронной компонентной базы двойного назначения, продукции таких производителей как XILINX, Intel (ex.ALTERA), Vicor, Microchip, Texas Instruments, Analog Devices, Mini-Circuits, Amphenol, Glenair.

Сотрудничество с глобальными дистрибьюторами электронных компонентов, предоставляет возможность заказывать и получать с международных складов практически любой перечень компонентов в оптимальные для Вас сроки.

На всех этапах разработки и производства наши партнеры могут получить квалифицированную поддержку опытных инженеров.

Система менеджмента качества компании отвечает требованиям в соответствии с ГОСТ Р ИСО 9001, ГОСТ РВ 0015-002 и ЭС РД 009

Офис по работе с юридическими лицами:

105318, г.Москва, ул.Щербаковская д.3, офис 1107, 1118, ДЦ «Щербаковский»

Телефон: +7 495 668-12-70 (многоканальный)

Факс: +7 495 668-12-70 (доб.304)

E-mail: info@moschip.ru

Skype отдела продаж:

moschip.ru

moschip.ru_4

moschip.ru_6

moschip.ru_9