

NEW

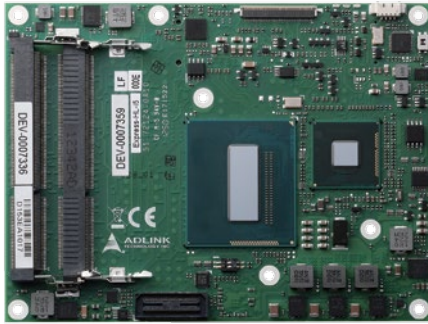

Features

- 4th Generation Intel® Core™ with Intel® QM87 Express Chipset and Intel® Celeron® Processors with Intel® HM86 Express Chipset
- Up to 16GB Dual Channel DDR3L at 1600MHz
- Three DDI ports support 3 independent displays
- Seven PCIe x1, one PCIe x16
- GbE, four SATA 6 Gb/s, four USB 3.0 and four USB 2.0
- Supports Smart Embedded Management Agent (SEMA) functions
- Extreme Rugged™ operating temperature: -40°C to +85°C (optional)

Specifications

Core System

CPU	4th Generation Intel® Core™ and Celeron® Processors (Mobile) - 22nm (also known as "Haswell Platform") i7-4860EQ 1.8 GHz (3.2 GHz Turbo), 47W (4C/GT3) i7-4700EQ 2.4 GHz (3.4 GHz Turbo), 47W (4C/GT2) i5-4400E 2.7 GHz (3.3 GHz Turbo), 37W (2C/GT2) i5-4402E 1.6 GHz (2.7 GHz Turbo), 25W (2C/GT2) i3-4100E 2.4 GHz (no Turbo) 3MB, 37W (2C/GT2) i3-4102E 1.6 GHz (no Turbo) 3MB, 25W (2C/GT2) Celeron® 2000E 2.2 GHz (no Turbo) 35W (2C/GT1) Celeron® 2002E 1.5 GHz (no Turbo) 25W (2C/GT1) Supports: Intel® VT, Intel® TXT, Intel® SSE4.2, Intel® HT Technology, Intel® 64 Architecture, Execute Disable Bit, Intel® Turbo Boost Technology 2.0, Intel® AVX2, Intel® AES-NI, PCLMULQDQ Instruction, Intel® Secure Key and Intel® TSX. Note: Availability of the features may vary between processor SKUs.
Memory	Dual channel non-ECC 1600/1333 MHz DDR3L memory up to 16GB in dual SODIMM socket
Embedded BIOS	AMI EFI with CMOS backup in 8MB SPI BIOS with Intel® AMT 9.0 support
L3 Cache	6MB for i7-4700EQ, 3MB for i5-4400E, i5-4402E, i3-4100E and i3-4102E
Expansion Busses	PCI Express x16 (Gen3) or PCI Express (2 x8 or 1 x8 with 2 x4) 6 PCI Express x1 (AB): Lanes 0/1/2/3/4/5 1 PCI Express x1 (CD): Lane 6 LPC bus, SMBus (system), I ² C (user)
SEMA Board Controller	Supports: Voltage/Current monitoring, Power sequence debug support, AT/ATX mode control, Logistics and Forensic information, Flat Panel Control, General Purpose I ² C, Failsafe BIOS (dual BIOS), Watchdog Timer and Fan Control
Debug Headers	40-pin multipurpose flat cable connector Use in combination with DB-40 debug module Providing BIOS POST code LED, BMC access, SPI BIOS flashing, Power Testpoints, Debug LEDs 60-pin XDP header for ICE debug of CPU/Chipset

Video

GPU Feature Support	Generation 7.5 graphics core architecture, supporting 3 independent and simultaneous display combinations of DisplayPort / HDMI / LVDS monitors Encode/transcode HD content Playback of high definition content including Blu-ray Disc
Digital Display Interface	DDI1 supporting DisplayPort / HDMI / DVI DDI2 supporting DisplayPort / HDMI / DVI DDI3 supporting DisplayPort / HDMI / DVI
VGA	Analog VGA support with 300 MHz DAC
LVDS	Analog monitor support up to QXGA (2048 x 1536) Single/dual channel 18/24-bit LVDS from eDP (two lanes)

Audio

Chipset	Intel® HD Audio integrated in SOC
Audio Codec	Located on carrier Express-BASE6 (ALC886 standard supported)

Ethernet

Intel® MAC/PHY	I217LM (Enterprise SKU) with AMT 9.0 support
Interface	10/100/1000 GbE connection

I/O Interfaces

USB	4x USB 3.0 (USB 0,1,2,3) 4x USB 2.0 (USB 4,5,6,7)
SATA	Four ports SATA 6Gb/s (SATA0, SATA1, SATA2, SATA3)
Serial	2 UART ports COM1/2 with console redirection
GPIO	4 GPO and 4 GPI with interrupt

Super I/O

Supported on carrier if needed (standard support for W83627DHG-P)

TPM

Chipset	Atmel AT97SC3204
Type	TPM 1.2

Power

Standard Input	ATX = 12V±5% / 5Vsb ±5% or AT = 12V ±5%
Wide Input	ATX = 8.5~20 V / 5Vsb ±5% or AT = 8.5~20V
Management	ACPI 4.0 compliant, Smart Battery support
Power States	C1-C6, S0, S1, S4, S3, S5, S5 ECO mode (Wake on USB S3/S4, WOL S3/S4/S5)
ECO mode	Supports deep S5 mode for power saving

Mechanical and Environmental

Form Factor	PICMG COM.0: Rev 2.1 Type 6
Dimension	Basic size: 125 mm x 95 mm
Operating Temperature	Standard: 0°C to +60°C Extreme Rugged™: -40°C to +85°C (optional)
Humidity	5-90% RH operating, non-condensing 5-95% RH storage (and operating with conformal coating)
Shock and Vibration	IEC 60068-2-64 and IEC-60068-2-27 MIL-STD-202F, Method 213B, Table 213-I, Condition A and Method 214A, Table 214-I, Condition D
HALT tested	Thermal Stress, Vibration Stress, Thermal Shock and Combined Test

Operating Systems

Standard Support	Windows 7/8 32/64-bit, Linux 32/64-bit
Extended Support (BSP)	WES7/8, Linux, VxWorks, QNX

Functional Diagram

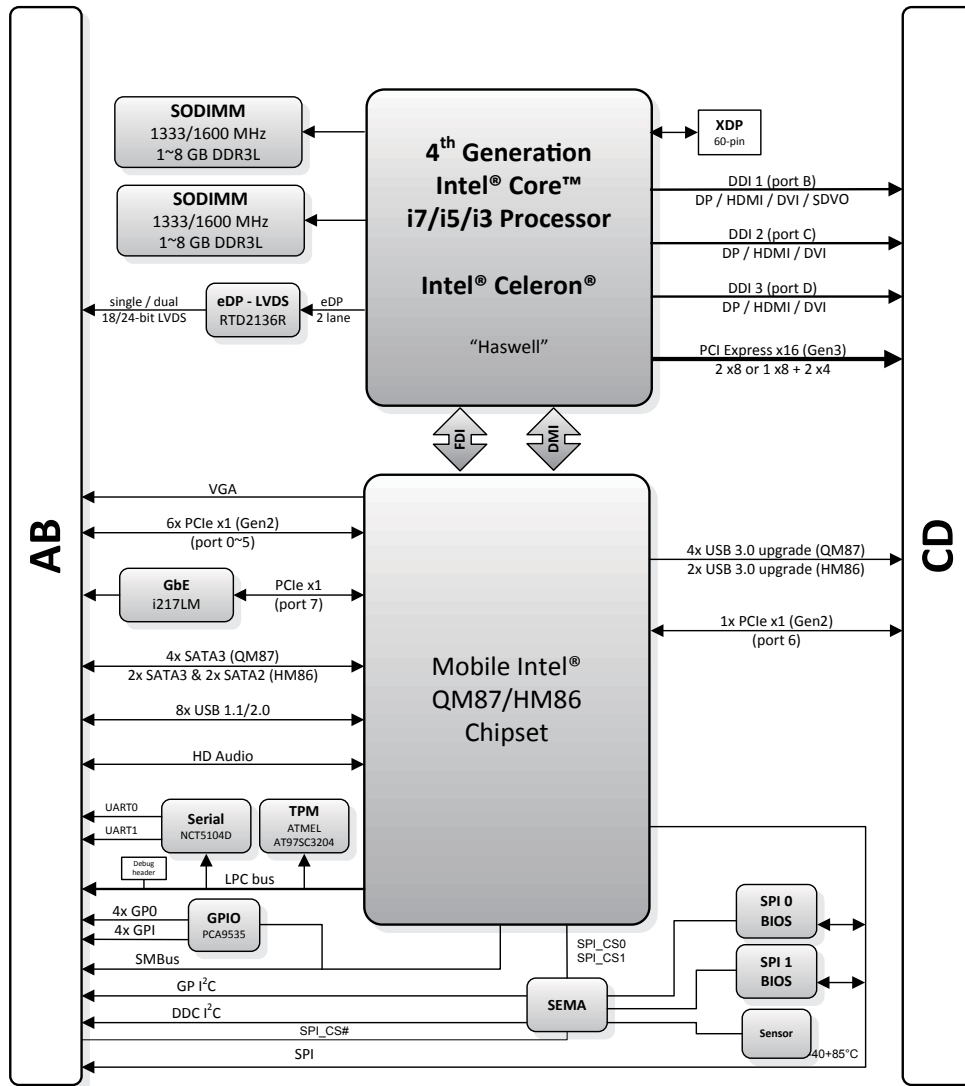

Ordering Information

Modules

Model Number	Description/Configuration
Express-HL-i7-4860EQ	COM Express® Basic Size Type 6 Module with Intel® Core™ i7-4860EQ at 1.8 GHz with GT3 level graphics
Express-HL-i7-4700EQ	COM Express® Basic Size Type 6 Module with Intel® Core™ i7-4700EQ at 2.4/1.7 GHz with GT2 level graphics
Express-HL-i5-4400E	COM Express® Basic Size Type 6 Module with Intel® Core™ i5-4400E at 2.7 GHz with GT2 level graphics
Express-HL-i3-4100E	COM Express® Basic Size Type 6 Module with Intel® Core™ i3-4100E at 2.4 GHz with GT2 level graphics
Express-HL-i5-4402E	COM Express® Basic Size Type 6 Module with Intel® Core™ i5-4402E at 1.6 GHz with GT2 level graphics
Express-HL-i3-4102E	COM Express® Basic Size Type 6 Module with Intel® Core™ i3-4102E at 1.6 GHz with GT2 level graphics
Express-HL-2000E	COM Express® Basic Size Type 6 Module with Celeron® 2000E 2.2 GHz (no Turbo) 35W (2C/GT1)
Express-HL-2002E	COM Express® Basic Size Type 6 Module with Celeron® 2002E 1.5 GHz (no Turbo) 25W (2C/GT1)

Accessories

Model Number	Description/Configuration
Heat Spreaders	
HTS-HL-B	Heatspreader for Express-HL with threaded standoffs for bottom mounting
HTS-HL-BT	Heatspreader for Express-HL with through hole standoffs for top mounting
Passive Heatsinks	
THS-HL-BL	Low profile heatsink for Express-HL with threaded standoffs for bottom mounting
THS-HL-BT	Low profile heatsink for Express-HL with through hole standoffs for top mounting
THSH-HL-BL	High profile heatsink for Express-HL with threaded standoffs for bottom mounting
Active Heatsink	
THSF-HL-BL	High profile heatsink with Fan for Express-HL with threaded standoffs for bottom mounting

Данный компонент на территории Российской Федерации

Вы можете приобрести в компании MosChip.

Для оперативного оформления запроса Вам необходимо перейти по данной ссылке:

<http://moschip.ru/get-element>

Вы можете разместить у нас заказ для любого Вашего проекта, будь то серийное производство или разработка единичного прибора.

В нашем ассортименте представлены ведущие мировые производители активных и пассивных электронных компонентов.

Нашей специализацией является поставка электронной компонентной базы двойного назначения, продукции таких производителей как XILINX, Intel (ex.ALTERA), Vicor, Microchip, Texas Instruments, Analog Devices, Mini-Circuits, Amphenol, Glenair.

Сотрудничество с глобальными дистрибьюторами электронных компонентов, предоставляет возможность заказывать и получать с международных складов практически любой перечень компонентов в оптимальные для Вас сроки.

На всех этапах разработки и производства наши партнеры могут получить квалифицированную поддержку опытных инженеров.

Система менеджмента качества компании отвечает требованиям в соответствии с ГОСТ Р ИСО 9001, ГОСТ РВ 0015-002 и ЭС РД 009

Офис по работе с юридическими лицами:

105318, г.Москва, ул.Щербаковская д.3, офис 1107, 1118, ДЦ «Щербаковский»

Телефон: +7 495 668-12-70 (многоканальный)

Факс: +7 495 668-12-70 (доб.304)

E-mail: info@moschip.ru

Skype отдела продаж:

moschip.ru

moschip.ru_4

moschip.ru_6

moschip.ru_9