

RFPD3540

GaAs/GaN Power Doubler Hybrid
45MHz to 1218MHz

The RFPD3540 is a Hybrid Power Doubler amplifier module. The part employs GaAs MesFET, GaAs pHEMT die and GaN HEMT die, has high output capability, and operates from 45MHz to 1218MHz. It provides excellent linearity and superior return loss performance with low noise and optimal reliability.



Package: SOT-115J

Features

- Extremely High Output Capability
- Excellent Linearity
- Superior Return Loss Performance
- Optimal Reliability
- Low Noise
- Unconditionally Stable Under All Terminations
- 27.0dB Min. Gain at 1218MHz
- 450mA Max. at 24VDC

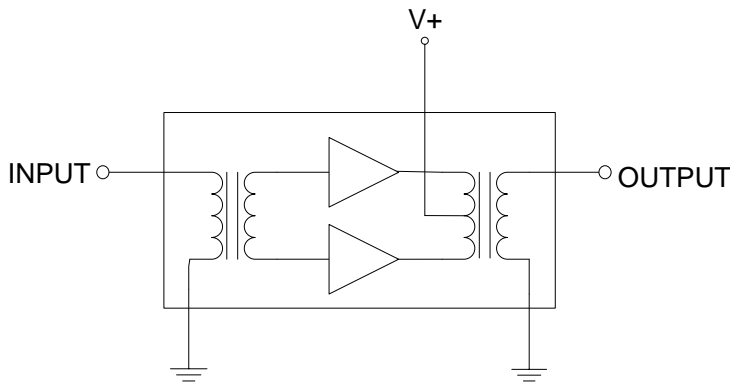

Functional Block Diagram

Ordering Information

RFPD3540 Box with 50 pieces

Applications

- 45MHz to 1218MHz CATV Amplifier Systems
- DOCSIS 3.1 Compliant

RFPD3540

Absolute Maximum Ratings

Parameter	Rating	Unit
RF Input Voltage (single tone)	75	dBmV
DC Supply Over-Voltage (5 minutes)	30	V
Storage Temperature	-40 to +100	°C
Operating Mounting Base Temperature	-30 to +100	°C



Caution! ESD sensitive device.



RoHS status based on EU Directive 2011/65/EU .

Exceeding any one or a combination of the Absolute Maximum Rating conditions may cause permanent damage to the device. Extended application of Absolute Maximum Rating conditions to the device may reduce device reliability. Specified typical performance or functional operation of the device under Absolute Maximum Rating conditions is not implied.

Electrical Specifications

Parameter	Specification			Unit	Condition
	Min	Typ	Max		
General Performance. Test conditions unless otherwise noted: $V_+ = 24V$; $T_{MB} = 35^\circ C$; $Z_S = Z_L = 75\Omega$					
Operating Frequency Range	45		1218	MHz	
Power Gain		27.0		dB	$f = 45MHz$
	27.0	28.0	29.0	dB	$f = 1218MHz$
Slope[1]	0.5	1.0	2.0	dB	$f = 45MHz$ to $1218MHz$
Flatness of Frequency Response			0.8	dB	$f = 45MHz$ to $1218MHz$
Input Return Loss	-20			dB	$f = 45MHz$ to $320MHz$
	-18			dB	$f = 320MHz$ to $640MHz$
	-17			dB	$f = 640MHz$ to $870MHz$
	-16			dB	$f = 870MHz$ to $1000MHz$
	-15			dB	$f = 1000MHz$ to $1218MHz$
Output Return Loss	-20			dB	$f = 45MHz$ to $320MHz$
	-19			dB	$f = 320MHz$ to $640MHz$
	-18			dB	$f = 640MHz$ to $870MHz$
	-17			dB	$f = 870MHz$ to $1000MHz$
	-16			dB	$f = 1000MHz$ to $1218MHz$
Noise Figure		5.1	5.5	dB	$f = 50MHz$ to $1218MHz$
Total Current Consumption (DC)		420	450	mA	

RFPD3540



RFMD + TriQuint = Qorvo

Parameter	Specification			Unit	Condition
	Min	Typ	Max		
Distortion Data 40MHz to 550MHz. Test conditions unless otherwise noted: V+ = 24V; TMB = 35°C; ZS = ZL = 75Ω					
CTB		-80		dBc	VO = 59dBmV at 1218MHz, 22dB extrapolated tilt, 79 analog channels plus 111 digital channels (-6dB offset)[2][4]
XMOD		-76		dBc	
CSO		-80		dBc	
CIN		55		dB	
Distortion Data 40MHz to 550MHz. Test conditions unless otherwise noted: V+ = 24V; TMB = 35°C; ZS = ZL = 75Ω					
CTB		-76	-72	dBc	VO = 58dBmV at 1218MHz, 16.5dB extrapolated tilt, 79 analog channels plus 111 digital channels (-6dB offset)[3][4]
XMOD		-70	-65	dBc	
CSO		-80	-70	dBc	
CIN	55	58		dB	

1. The slope is defined as the difference between the gain at the start frequency and the gain at the stop frequency.
2. 79 analog channels, NTSC frequency raster: 55.25MHz to 547.25MHz, +37dBmV to +46.4dBmV tilted output level, plus 111 digital channels, -6dB offset relative to the equivalent analog carrier.
3. 79 analog channels, NTSC frequency raster: 55.25MHz to 547.25MHz, +41.5dBmV to +48.5dBmV tilted output level, plus 111 digital channels, -6dB offset relative to the equivalent analog carrier.
4. Composite Second Order (CSO) - The CSO parameter (both sum and difference products) is defined by ANSI/SCTE 6. Composite Triple Beat (CTB) - The CTB parameter is defined by ANSI/SCTE 6. Cross Modulation (XMOD) - Cross modulation (XMOD) is measured at baseband (selective voltmeter method), referenced to 100% modulation of the carrier being tested. Carrier to Intermodulation Noise (CIN) - The CIN parameter is defined by ANSI/SCTE 17 (Test procedure for carrier to noise).

RFPD3540

Package Drawing (Dimensions in millimeters)

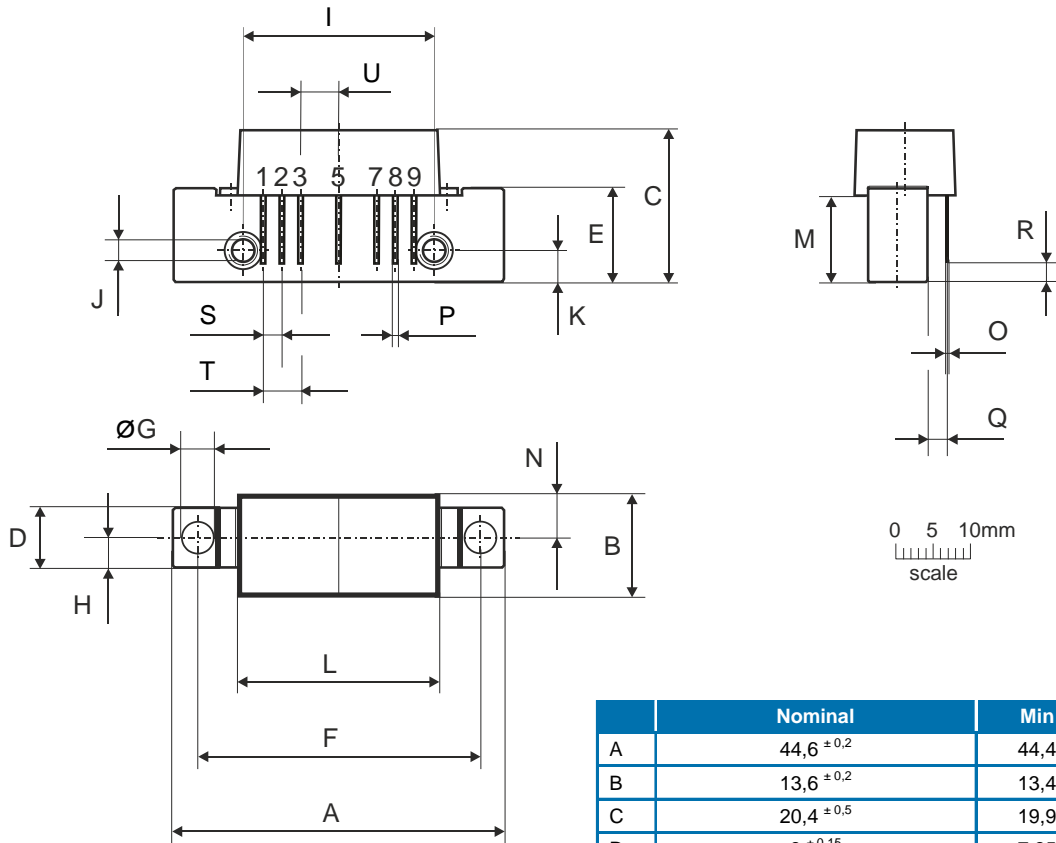

Notes:

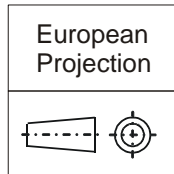

Pinning:

Pin	Name
1	Input
2-3	GND
4	
5	V+
6	
7-8	GND
9	Output

	Nominal	Min	Max
A	44,6 ± 0,2	44,4	44,8
B	13,6 ± 0,2	13,4	13,8
C	20,4 ± 0,5	19,9	20,9
D	8 ± 0,15	7,85	8,15
E	12,6 ± 0,15	12,45	12,75
F	38,1 ± 0,2	37,9	38,3
G	4 ^{+0,2/-0,05}	3,95	4,2
H	4 ± 0,2	3,8	4,2
I	25,4 ± 0,2	25,2	25,6
J	UNC 6-32	-	-
K	4,2 ± 0,2	4,0	4,4
L	27,2 ± 0,2	27,0	27,4
M	11,6 ± 0,5	11,1	12,1
N	5,8 ± 0,4	5,4	6,2
O	0,25 ± 0,02	0,23	0,27
P	0,45 ± 0,03	0,42	0,48
Q	2,54 ± 0,3	2,24	2,84
R	2,54 ± 0,5	2,04	3,04
S	2,54 ± 0,25	2,29	2,79
T	5,08 ± 0,25	4,83	5,33
U	5,08 ± 0,25	4,83	5,33

RFPD3540



Contact Information

For the latest specifications, additional product information, worldwide sales and distribution locations:

Web: www.rfmd.com

Tel: 1-844-890-8163

Email: customer.support@qorvo.com

For information about the merger of RFMD and TriQuint as Qorvo:

Web: www.qorvo.com

Important Notice

The information contained herein is believed to be reliable. RFMD makes no warranties regarding the information contained herein. RFMD assumes no responsibility or liability whatsoever for any of the information contained herein. RFMD assumes no responsibility or liability whatsoever for the use of the information contained herein. The information contained herein is provided "AS IS, WHERE IS" and with all faults, and the entire risk associated with such information is entirely with the user. All information contained herein is subject to change without notice. Customers should obtain and verify the latest relevant information before placing orders for RFMD products. The information contained herein or any use of such information does not grant, explicitly or implicitly, to any party any patent rights, licenses, or any other intellectual property rights, whether with regard to such information itself or anything described by such information.

RFMD products are not warranted or authorized for use as critical components in medical, life-saving, or life-sustaining applications, or other applications where a failure would reasonably be expected to cause severe personal injury or death.

Данный компонент на территории Российской Федерации

Вы можете приобрести в компании MosChip.

Для оперативного оформления запроса Вам необходимо перейти по данной ссылке:

<http://moschip.ru/get-element>

Вы можете разместить у нас заказ для любого Вашего проекта, будь то серийное производство или разработка единичного прибора.

В нашем ассортименте представлены ведущие мировые производители активных и пассивных электронных компонентов.

Нашей специализацией является поставка электронной компонентной базы двойного назначения, продукции таких производителей как XILINX, Intel (ex.ALTERA), Vicor, Microchip, Texas Instruments, Analog Devices, Mini-Circuits, Amphenol, Glenair.

Сотрудничество с глобальными дистрибьюторами электронных компонентов, предоставляет возможность заказывать и получать с международных складов практически любой перечень компонентов в оптимальные для Вас сроки.

На всех этапах разработки и производства наши партнеры могут получить квалифицированную поддержку опытных инженеров.

Система менеджмента качества компании отвечает требованиям в соответствии с ГОСТ Р ИСО 9001, ГОСТ РВ 0015-002 и ЭС РД 009

Офис по работе с юридическими лицами:

105318, г.Москва, ул.Щербаковская д.3, офис 1107, 1118, ДЦ «Щербаковский»

Телефон: +7 495 668-12-70 (многоканальный)

Факс: +7 495 668-12-70 (доб.304)

E-mail: info@moschip.ru

Skype отдела продаж:

moschip.ru

moschip.ru_4

moschip.ru_6

moschip.ru_9