



ON Semiconductor®

Instruction Manual for
TOUCH/LRACOMBOGEVB Demo Board

Scope

The TOUCH/LRACOMBOGEVB demo showcases ON Semiconductor’s High-Accuracy Capacitive Touch Sensor (LC717A10AR) along with Linear Vibrator Driver (LC898301XA) for haptic feedback and an 8-bit Microcontroller (LC87F1M16A). The following is an instruction manual for the operation of this demo board.

Contents

Necessary Equipment	3
Overview	3
Block Diagram	4
ON Semiconductor Part Links	4
Touch Key Functions	5
Connection of USB Cable	5
Key Layout	6
Normal Key Action.....	6
Slide Key Action	7
Proximity Key Action	8
Haptic Functions	9
Vibration Level	9
Change Resonance Frequency.....	9
Other Functions	11
Touch ON Automatic Cancellation	11
Reset Switches	11
Related Documents	12
Revision History	12

Necessary Equipment:

- 1 Mini-B USB Cable with PC (Figure 1)
- or
- 1 AC to DC 5V USB adapter (Figure 2)



Figure 1: Mini-B USB cable



Figure 2: USB adapter

Overview:

Microcontroller (LC87F1M16A) distinguishes the keys of Touch Switch (LC717A10AR) by using I²C and control the actuator of Haptics (LC898301XA), LED and speaker. The power supply is supplied from USB.

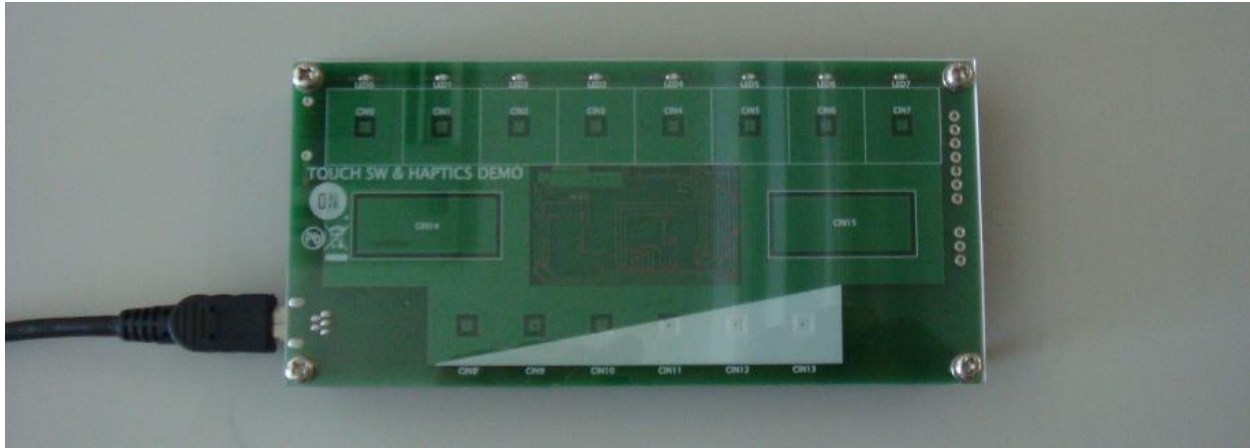
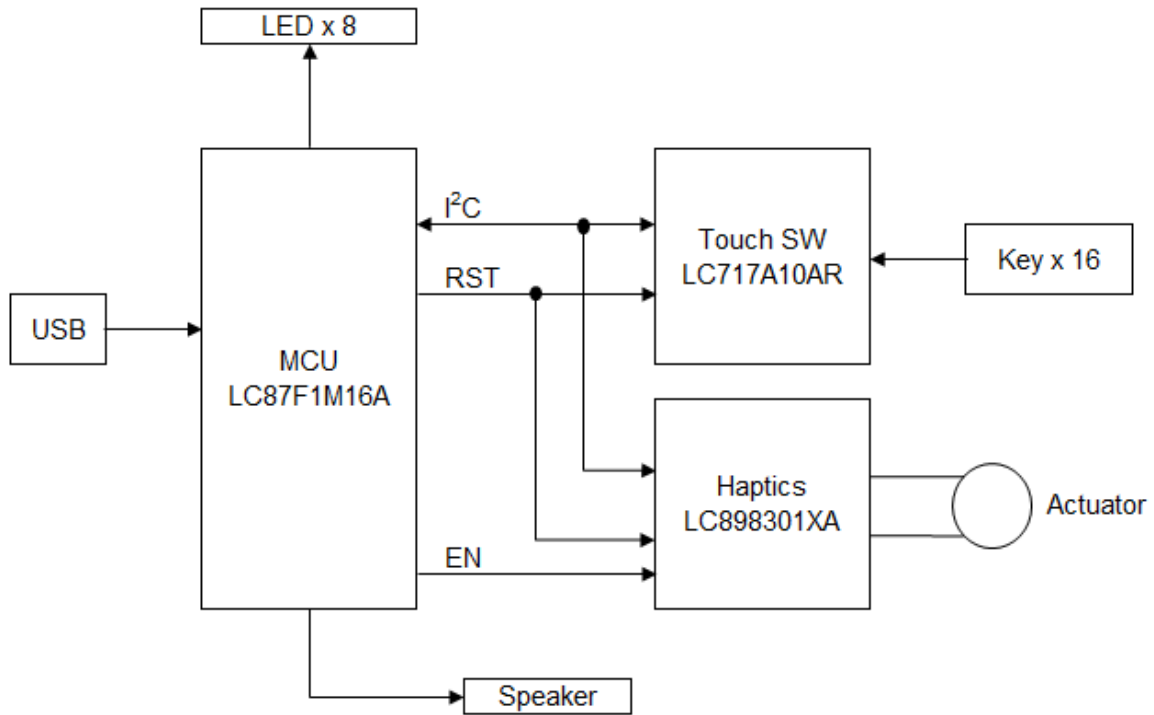

Figure 3: Board with USB cable

Block Diagram:



ON Semiconductor IC Links

LC717A10AR

<http://onsemi.com/PowerSolutions/product.do?id=LC717A10AR>

LC898301XA

<http://onsemi.com/PowerSolutions/product.do?id=LC898301XA>

LC87F1M16A

<http://onsemi.com/PowerSolutions/product.do?id=LC87F1M16A>

Touch Key Functions:

1. Connect USB cable

LED turns on for one second when 5V is applied to VDD.

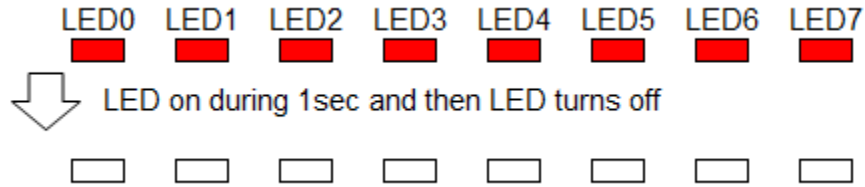

LED blinks three times when USB is connected if the USB driver is available. (USB driver is optional. It is necessary when updating the firmware.)

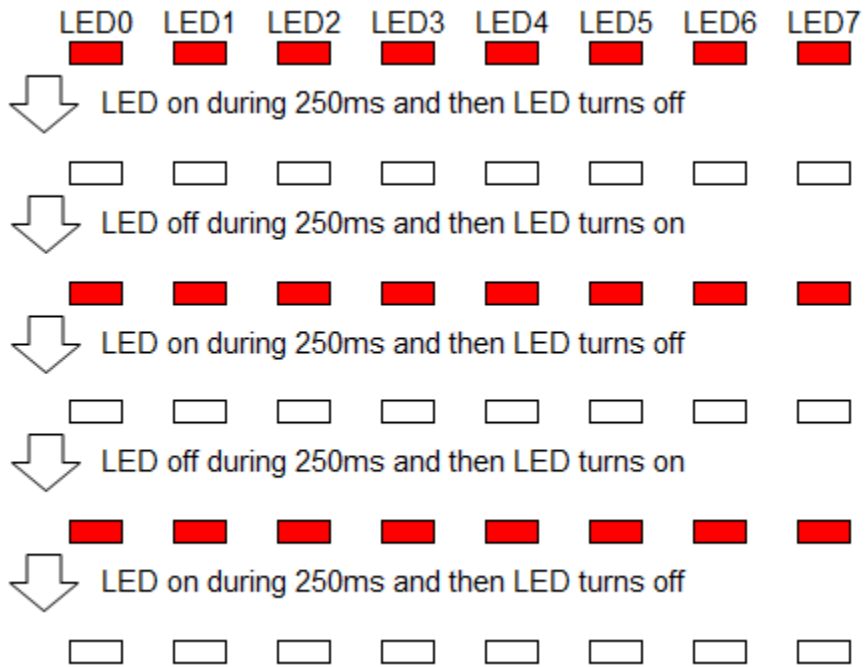

2. Key Layout

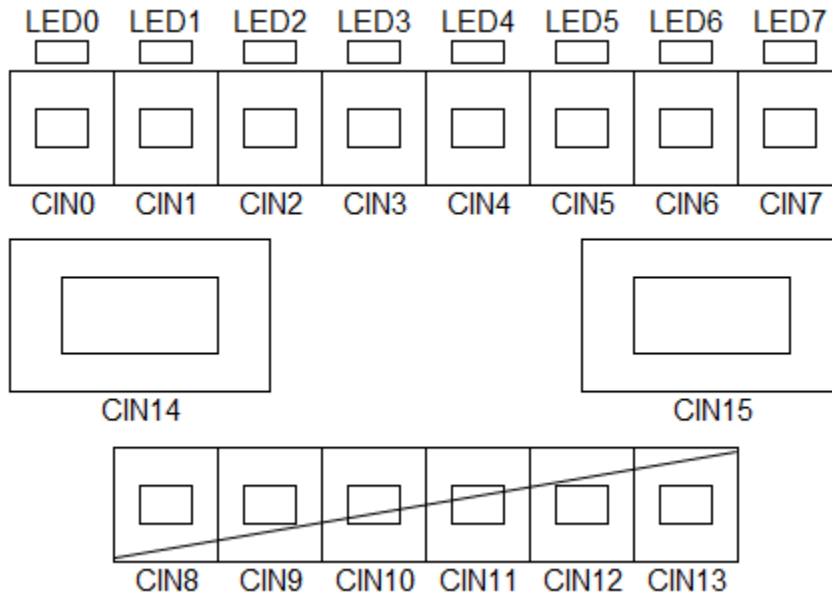

3. Normal Key Action

When key is touched upper LED of each key turns ON.

e.g. CIN0 is touched LED0 turns ON.

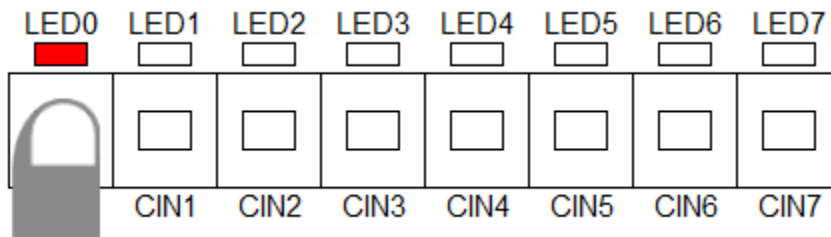

When multiple keys are touched.

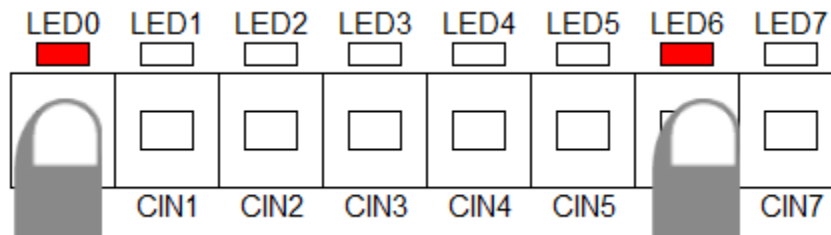

When key is touched, speaker plays respected musical scale.

CIN0 is "Do", CIN1 is "Re" ,,,, CIN6 is "Si", and CIN7 is upper "Do".

4. Slide Key Action

These slide keys can change the sensitivity (AMP gain and threshold level) of the Proximity Keys (CIN14,CIN15).

The slide keys have 11 kinds of sensitivity levels .

When touch the slide key, the LED of each level is ON.

e.g. Level 3

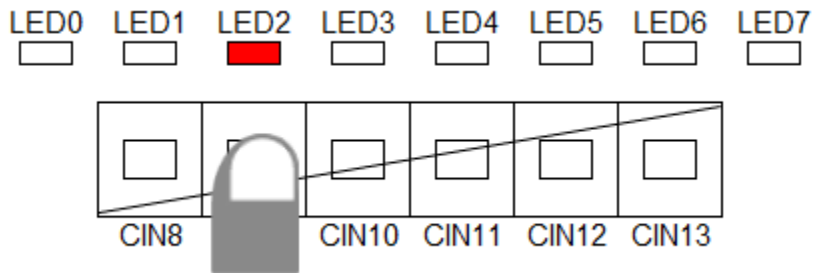

move right on the Touch key,

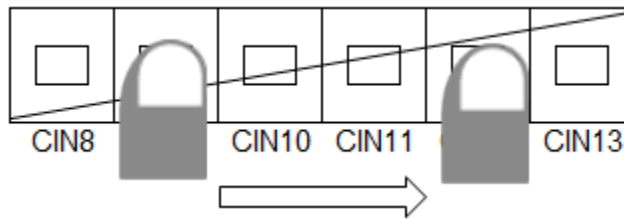

to increase the sensitivity level.

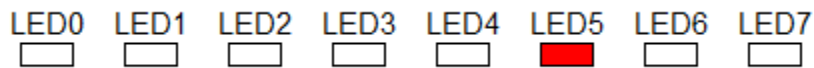



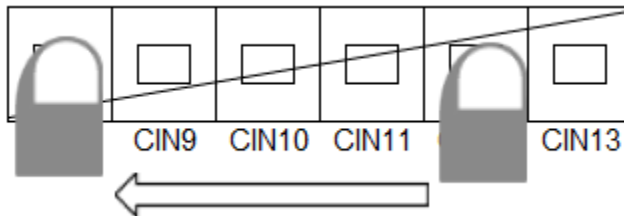



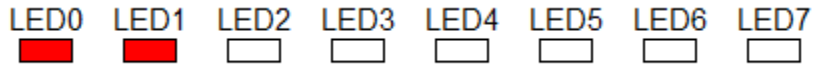

















































































move left on the Touch key,



to decrease the sensitivity level.



Correspondence of the sensitivity levels of LED and touch key.

Level	LED0	LED1	LED2	LED3	LED4	LED5	LED6	LED7	Touch key
1									CIN8
2									CIN8 and CIN9
3									CIN9
4									CIN9 and CIN10
5									CIN10
6									CIN10 and CIN11
7									CIN11
8									CIN11 and CIN12
9									CIN12
10									CIN12 and CIN13
11									CIN13

5. Proximity Key Action

These proximity keys react without touch.
Bleep sounds when keys are approached.

When close to CIN14 LEDs on left side turn ON.

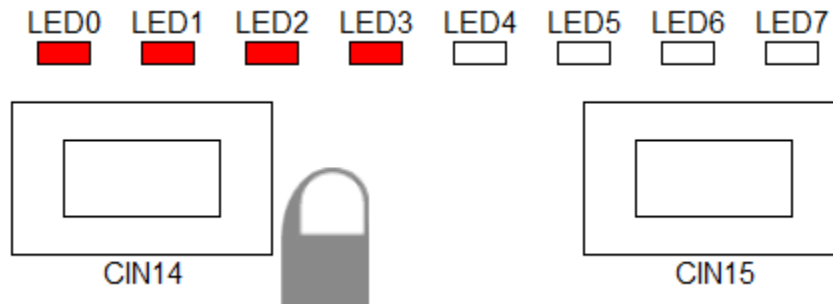

When close to CIN15 LEDs on right side turn ON.

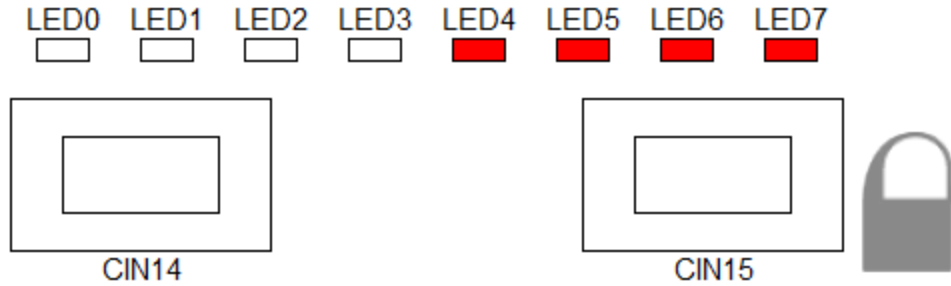

Haptic Functions:

When any key is touched, Linear Resonant Actuator (LRA) vibrates. There are several types of vibrations.

1. Vibration Level

When any key is touched, Linear Resonant Actuator (LRA) vibrates. Vibration level changes depending on touch key of CIN0 to CIN7.

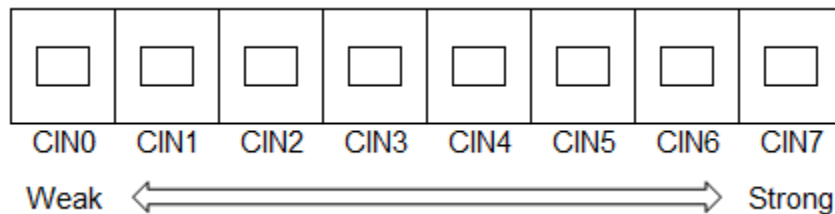

2. Change Resonance Frequency

Our Haptics IC can use 32 pattern of resonance frequency for LRA. This demo board uses two patterns 175Hz and 205Hz. (default is 205Hz)

When touching both CIN7 and CIN13, current resonance frequency is displayed.

e.g. Current frequency is 205Hz. (setting data is "0Bh")

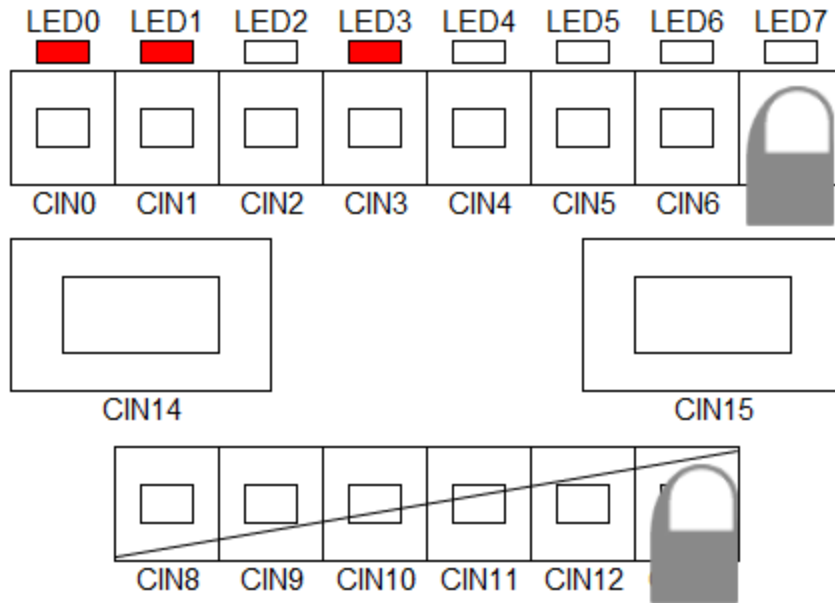

Hold keys during 5 seconds, then resonance frequency will change.
Bleep noise will sound at the same time.

If current resonance frequency is 205Hz, then resonance frequency will change to 175Hz.

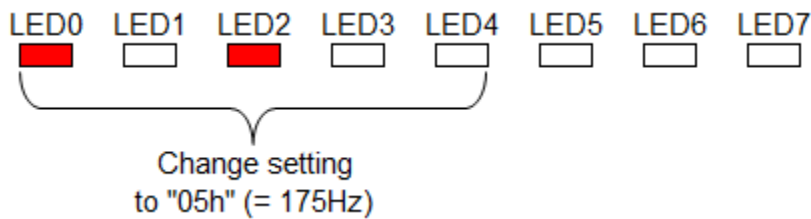

If current resonance frequency is 175Hz, then resonance frequency will change to 205Hz.

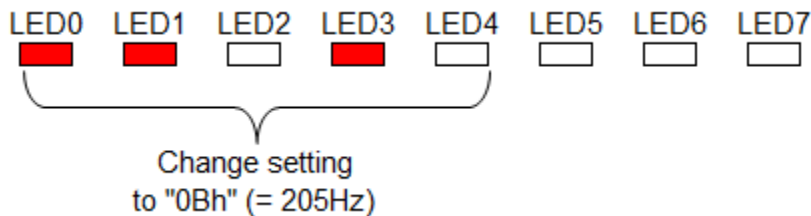

Other Functions

1. Touch ON Automatic Cancellation

LC717A10AR does not have Touch ON automatic cancellation function. So, the software implements the auto touch-off function for a fail-safe. Auto off time is about 8 seconds.

2. Reset Switches

If you observe the board is not a normal condition, push the Reset Switch (SW2) of the backside.

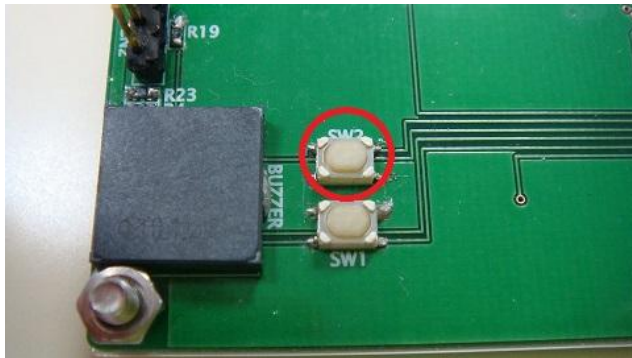

Figure 4: Reset Switch of MCU

SW1 is reset switch for LC717A10AR and LC898301XA. However MCU resets these ICs during the initialization process when MCU program starts up. So, normally SW1 is not used.

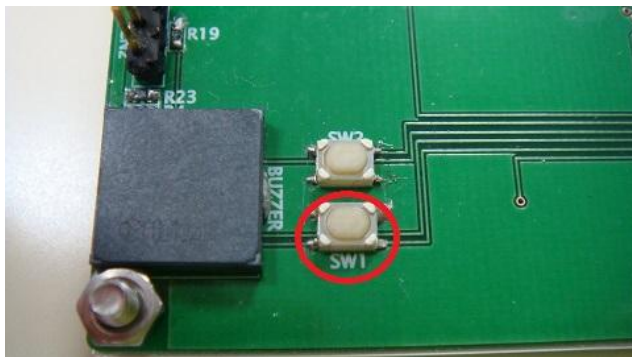

Figure 5: Reset Switch of LC717A10AR and LC898301XA

Related Documents

Supporting materials such as: Datasheets, Application Notes, Evaluation Kits/Boards, Evaluation Board Documents and Software are available for all three featured ON Semiconductor components. To obtain the most updated documentation please visit the ON Semiconductor Web site at www.onsemi.com and search part numbers: LC717A10AR (Touch Sensor), LC898301XA (Linear Vibrator Driver), and LC87F1M16A(Microcontroller).

Revision History

Version	Date	Details
1.0	xxxxx	Initial Release

Данный компонент на территории Российской Федерации

Вы можете приобрести в компании MosChip.

Для оперативного оформления запроса Вам необходимо перейти по данной ссылке:

<http://moschip.ru/get-element>

Вы можете разместить у нас заказ для любого Вашего проекта, будь то серийное производство или разработка единичного прибора.

В нашем ассортименте представлены ведущие мировые производители активных и пассивных электронных компонентов.

Нашей специализацией является поставка электронной компонентной базы двойного назначения, продукции таких производителей как XILINX, Intel (ex.ALTERA), Vicor, Microchip, Texas Instruments, Analog Devices, Mini-Circuits, Amphenol, Glenair.

Сотрудничество с глобальными дистрибьюторами электронных компонентов, предоставляет возможность заказывать и получать с международных складов практически любой перечень компонентов в оптимальные для Вас сроки.

На всех этапах разработки и производства наши партнеры могут получить квалифицированную поддержку опытных инженеров.

Система менеджмента качества компании отвечает требованиям в соответствии с ГОСТ Р ИСО 9001, ГОСТ РВ 0015-002 и ЭС РД 009

Офис по работе с юридическими лицами:

105318, г.Москва, ул.Щербаковская д.3, офис 1107, 1118, ДЦ «Щербаковский»

Телефон: +7 495 668-12-70 (многоканальный)

Факс: +7 495 668-12-70 (доб.304)

E-mail: info@moschip.ru

Skype отдела продаж:

moschip.ru

moschip.ru_4

moschip.ru_6

moschip.ru_9