



PCA9517

Level translating I²C-bus repeater

Rev. 03 — 30 January 2007

Product data sheet

1. General description

The PCA9517 is a CMOS integrated circuit that provides level shifting between low voltage (down to 0.9 V) and higher voltage (2.7 V to 5.5 V) I²C-bus or SMBus applications. While retaining all the operating modes and features of the I²C-bus system during the level shifts, it also permits extension of the I²C-bus by providing bidirectional buffering for both the data (SDA) and the clock (SCL) lines, thus enabling two buses of 400 pF. Using the PCA9517 enables the system designer to isolate two halves of a bus for both voltage and capacitance. The SDA and SCL pins are over voltage tolerant and are high-impedance when the PCA9517 is unpowered.

The 2.7 V to 5.5 V bus B-side drivers behave much like the drivers on the PCA9515A device, while the adjustable voltage bus A-side drivers drive more current and eliminate the static offset voltage. This results in a LOW on the B-side translating into a nearly 0 V LOW on the A-side which accommodates smaller voltage swings of lower voltage logic.

The static offset design of the B-side PCA9517 I/O drivers prevent them from being connected to another device that has rise time accelerator including the PCA9510, PCA9511, PCA9512, PCA9513, PCA9514, PCA9515A, PCA9516A, PCA9517 (B-side), or PCA9518. The A-side of two or more PCA9517s can be connected together, however, to allow a star topography with the A-side on the common bus, and the A-side can be connected directly to any other buffer with static or dynamic offset voltage. Multiple PCA9517s can be connected in series, A-side to B-side, with no build-up in offset voltage with only time of flight delays to consider.

The PCA9517 drivers are not enabled unless V_{CCA} is above 0.8 V and V_{CC} is above 2.5 V. The EN pin can also be used to turn the drivers on and off under system control. Caution should be observed to only change the state of the enable pin when the bus is idle.

The output pull-down on the B-side internal buffer LOW is set for approximately 0.5 V, while the input threshold of the internal buffer is set about 70 mV lower (0.43 V). When the B-side I/O is driven LOW internally, the LOW is not recognized as a LOW by the input. This prevents a lock-up condition from occurring. The output pull-down on the A-side drives a hard LOW and the input level is set at $0.3V_{CCA}$ to accommodate the need for a lower LOW level in systems where the low voltage side supply voltage is as low as 0.9 V.

2. Features

- 2 channel, bidirectional buffer isolates capacitance and allows 400 pF on either side of the device
- Voltage level translation from 0.9 V to 5.5 V and from 2.7 V to 5.5 V
- Footprint and functional replacement for PCA9515/15A
- I²C-bus and SMBus compatible

- Active HIGH repeater enable input
- Open-drain input/outputs
- Lock-up free operation
- Supports arbitration and clock stretching across the repeater
- Accommodates Standard mode and Fast mode I²C-bus devices and multiple masters
- Powered-off high-impedance I²C-bus pins
- A-side operating supply voltage range of 0.9 V to 5.5 V
- B-side operating supply voltage range of 2.7 V to 5.5 V
- 5 V tolerant I²C-bus and enable pins
- 0 Hz to 400 kHz clock frequency (the maximum system operating frequency may be less than 400 kHz because of the delays added by the repeater).
- ESD protection exceeds 2000 V HBM per JESD22-A114, 150 V MM per JESD22-A115, and 1000 V CDM per JESD22-C101
- Latch-up testing is done to JEDEC Standard JESD78 which exceeds 100 mA
- Packages offered: SO8 and TSSOP8

3. Ordering information

Table 1. Ordering information

$T_{amb} = -40\text{ }^{\circ}\text{C to }+85\text{ }^{\circ}\text{C}$

Type number	Topside mark	Package		Version
		Name	Description	
PCA9517D	PCA9517	SO8	plastic small outline package; 8 leads; body width 3.9 mm	SOT96-1
PCA9517DP	9517	TSSOP8 ^[1]	plastic thin shrink small outline package; 8 leads; body width 3 mm	SOT505-1

[1] Also known as MSOP8

4. Functional diagram

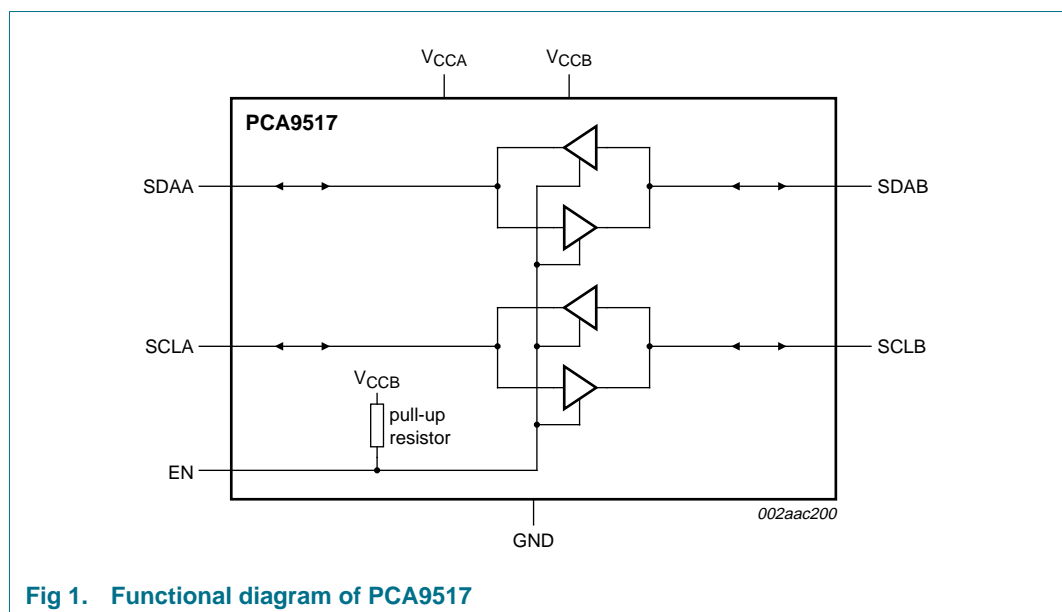

Fig 1. Functional diagram of PCA9517

5. Pinning information

5.1 Pinning

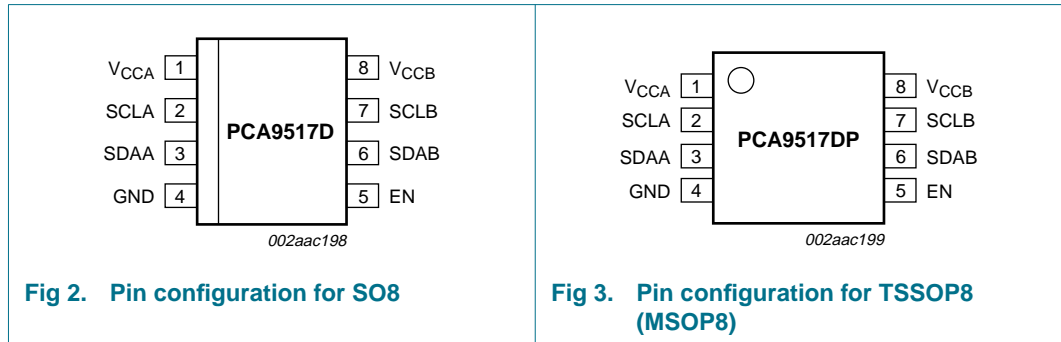

Fig 2. Pin configuration for SO8

Fig 3. Pin configuration for TSSOP8 (MSOP8)

5.2 Pin description

Table 2. Pin description

Symbol	Pin	Description
V _{CCA}	1	A-side supply voltage (0.9 V to 5.5 V)
SCLA	2	serial clock A-side bus
SDAA	3	serial data A-side bus
GND	4	supply ground (0 V)
EN	5	active HIGH repeater enable input
SDAB	6	serial data B-side bus
SCLB	7	serial clock B-side bus
V _{CCB}	8	B-side supply voltage (2.7 V to 5.5 V)

6. Functional description

Refer to [Figure 1 “Functional diagram of PCA9517”](#).

The PCA9517 enables I²C-bus or SMBus translation down to V_{CCA} as low as 0.9 V without degradation of system performance. The PCA9517 contains two bidirectional open-drain buffers specifically designed to support up-translation/down-translation between the low voltage (as low as 0.9 V) and a 3.3 V or 5 V I²C-bus or SMBus. All inputs and I/Os are overvoltage tolerant to 5.5 V even when the device is unpowered (V_{CCB} and/or V_{CCA} = 0 V). The PCA9517 includes a power-up circuit that keeps the output drivers turned off until V_{CCB} is above 2.5 V and the V_{CCA} is above 0.8 V. V_{CCB} and V_{CCA} can be applied in any sequence at power-up. After power-up and with the enable (EN) HIGH, a LOW level on the A-side (below 0.3V_{CCA}) turns the corresponding B-side driver (either SDA or SCL) on and drives the B-side down to about 0.5 V. When the A-side rises above 0.3V_{CCA} the B-side pull-down driver is turned off and the external pull-up resistor pulls the pin HIGH. When the B-side falls first and goes below 0.3V_{CCB} the A-side driver is turned on and the A-side pulls down to 0 V. The B-side pull-down is not enabled unless the B-side voltage goes below 0.4 V. If the B-side low voltage does not go below 0.5 V, the A-side driver will turn off when the B-side voltage is above 0.7V_{CCB}. If the B-side low voltage goes below 0.4 V, the B-side pull-down driver is enabled and the B-side will only

be able to rise to 0.5 V until the A-side rises above $0.3V_{CCA}$, then the B-side will continue to rise being pulled up by the external pull-up resistor. The V_{CCA} is only used to provide the $0.3V_{CCA}$ reference to the A-side input comparators and for the power good detect circuit. The PCA9517 logic and all I/Os are powered by the V_{CCB} pin.

6.1 Enable

The EN pin is active HIGH with an internal pull-up to V_{CCB} and allows the user to select when the repeater is active. This can be used to isolate a badly behaved slave on power-up until after the system power-up reset. It should never change state during an I²C-bus operation because disabling during a bus operation will hang the bus and enabling part way through a bus cycle could confuse the I²C-bus parts being enabled.

The enable pin should only change state when the global bus and the repeater port are in an idle state to prevent system failures.

6.2 I²C-bus systems

As with the standard I²C-bus system, pull-up resistors are required to provide the logic HIGH levels on the buffered bus (standard open-collector configuration of the I²C-bus). The size of these pull-up resistors depends on the system, but each side of the repeater must have a pull-up resistor. This part designed to work with Standard mode and Fast mode I²C-bus devices in addition to SMBus devices. Standard mode I²C-bus devices only specify 3 mA output drive; this limits the termination current to 3 mA in a generic I²C-bus system where Standard mode devices and multiple masters are possible. Under certain conditions higher termination currents can be used.

Please see Application Note *AN255, I²C/SMBus Repeaters, Hubs and Expanders* for additional information on sizing resistors and precautions when using more than one PCA9517 in a system or using the PCA9517 in conjunction with other bus buffers.

7. Application design-in information

A typical application is shown in [Figure 4](#). In this example, the system master is running on a 3.3 V I²C-bus while the slave is connected to a 1.2 V bus. Both buses run at 400 kHz. Master devices can be placed on either bus.

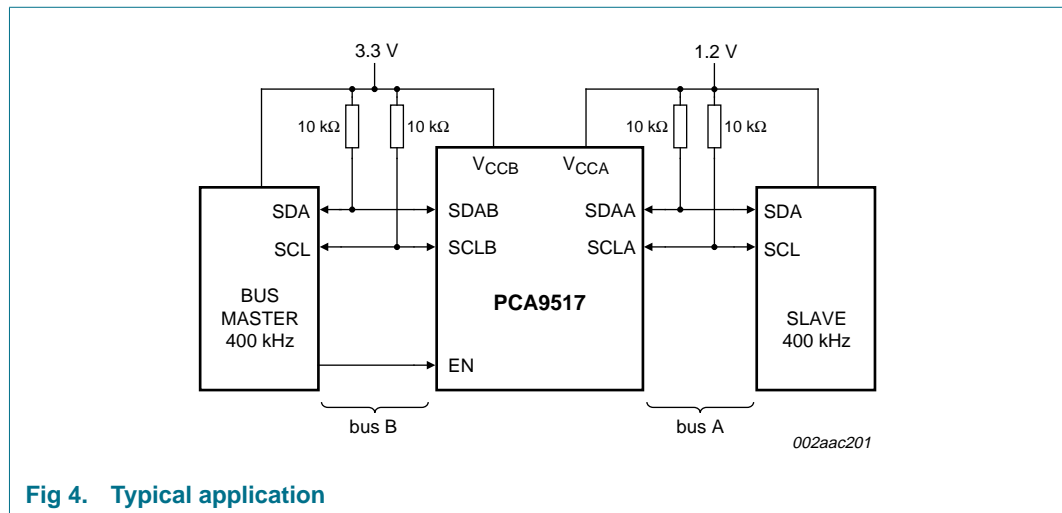

Fig 4. Typical application

The PCA9517 is 5 V tolerant, so it does not require any additional circuitry to translate between 0.9 V to 5.5 V bus voltages and 2.7 V to 5.5 V bus voltages.

When the A-side of the PCA9517 is pulled LOW by a driver on the I²C-bus, a comparator detects the falling edge when it goes below $0.3V_{CCA}$ and causes the internal driver on the B-side to turn on, causing the B-side to pull down to about 0.5 V. When the B-side of the PCA9517 falls, first a CMOS hysteresis type input detects the falling edge and causes the internal driver on the A-side to turn on and pull the A-side pin down to ground. In order to illustrate what would be seen in a typical application, refer to [Figure 8](#) and [Figure 9](#). If the bus master in [Figure 4](#) were to write to the slave through the PCA9517, waveforms shown in [Figure 8](#) would be observed on the A bus. This looks like a normal I²C-bus transmission except that the HIGH level may be as low as 0.9 V, and the turn on and turn off of the acknowledge signals are slightly delayed.

On the B bus side of the PCA9517, the clock and data lines would have a positive offset from ground equal to the V_{OL} of the PCA9517. After the 8th clock pulse, the data line will be pulled to the V_{OL} of the slave device which is very close to ground in this example. At the end of the acknowledge, the level rises only to the LOW level set by the driver in the PCA9517 for a short delay while the A bus side rises above $0.3V_{CCA}$ then it continues HIGH. It is important to note that any arbitration or clock stretching events require that the LOW level on the B bus side at the input of the PCA9517 (V_{IL}) be at or below 0.4 V to be recognized by the PCA9517 and then transmitted to the A bus side.

Multiple PCA9517 A-sides can be connected in a star configuration ([Figure 5](#)), allowing all nodes to communicate with each other.

Multiple PCA9517s can be connected in series ([Figure 6](#)) as long as the A-side is connected to the B-side. I²C-bus slave devices can be connected to any of the bus segments. The number of devices that can be connected in series is limited by repeater delay/time-of-flight considerations on the maximum bus speed requirements.

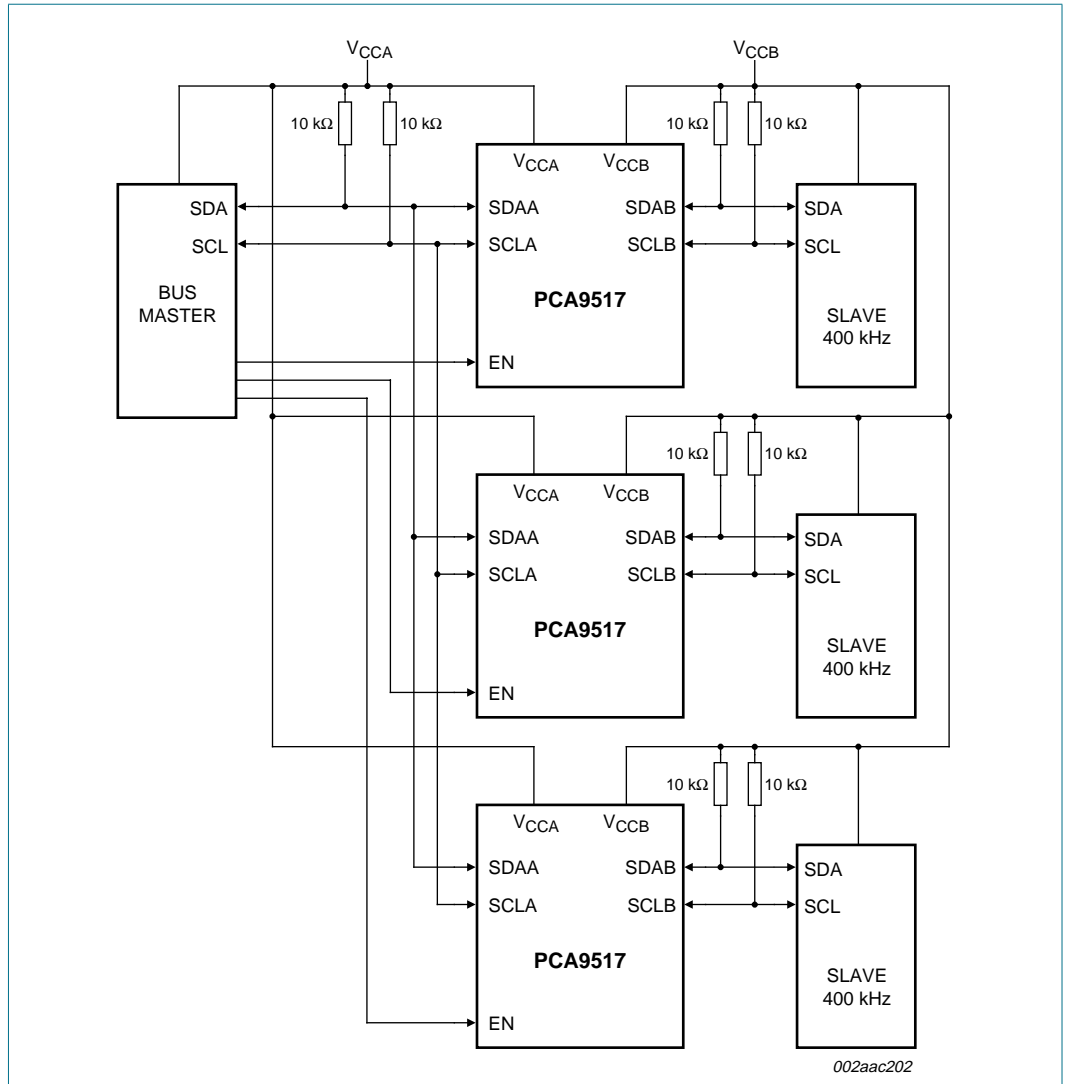

Fig 5. Typical star application

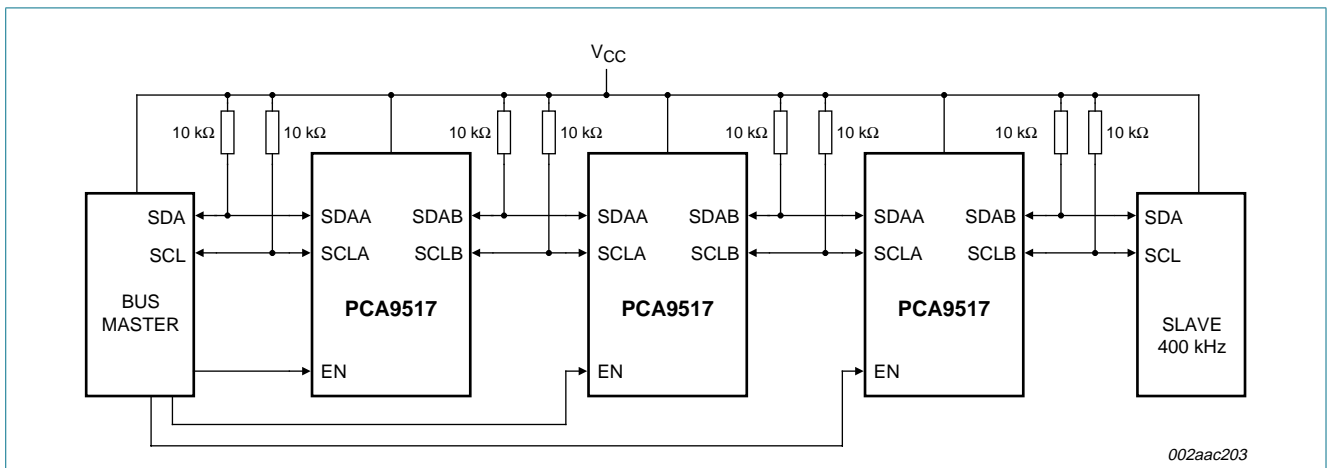

Fig 6. Typical series application

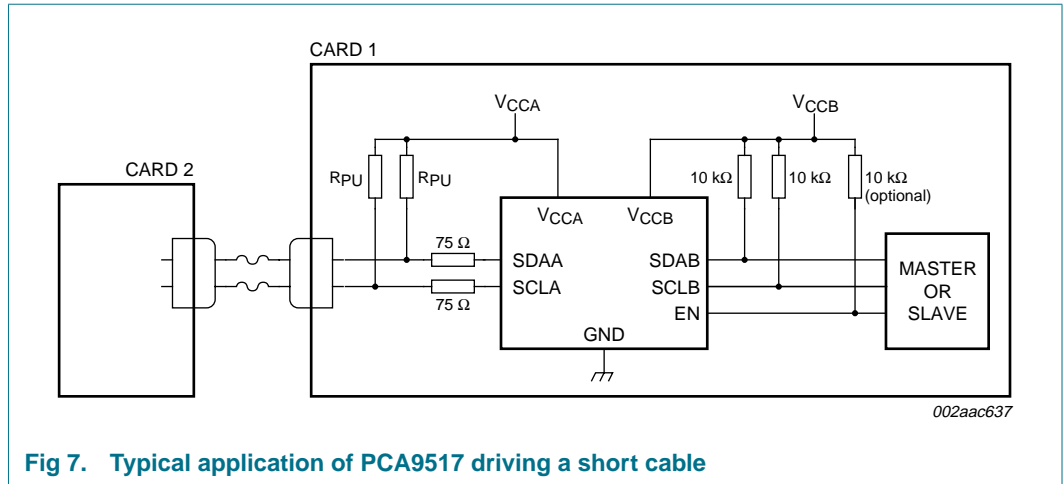

Fig 7. Typical application of PCA9517 driving a short cable

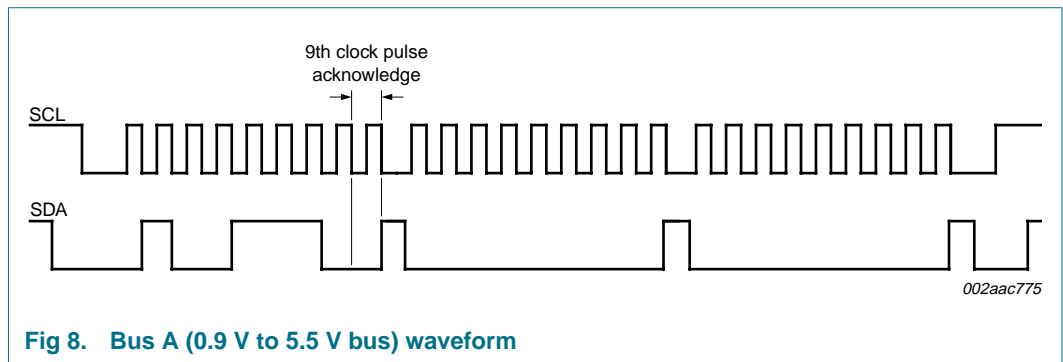

Fig 8. Bus A (0.9 V to 5.5 V bus) waveform

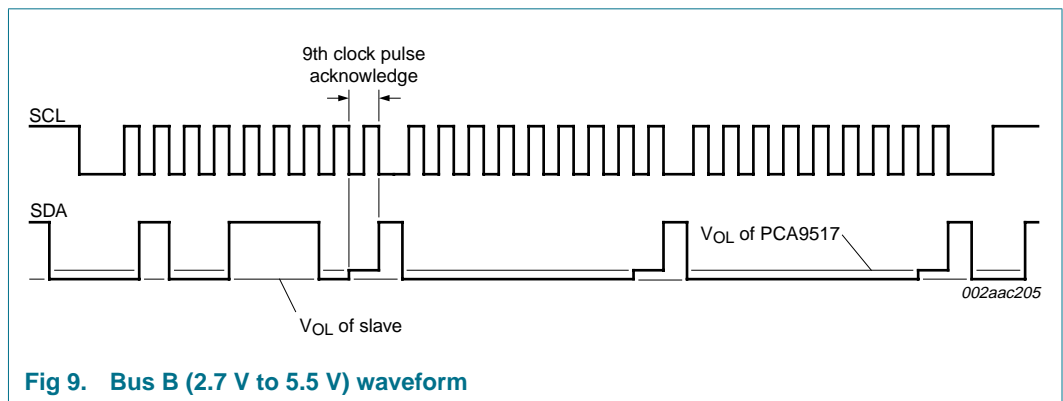

Fig 9. Bus B (2.7 V to 5.5 V) waveform

8. Limiting values

Table 3. Limiting values

In accordance with the Absolute Maximum Rating System (IEC 60134).

Symbol	Parameter	Conditions	Min	Max	Unit
V _{CCB}	supply voltage, B-side bus	2.7 V to 5.5 V	-0.5	+7	V
V _{CCA}	supply voltage, A-side bus	adjustable	-0.5	+7	V
V _{bus}	voltage on I ² C-bus B-side, or enable (EN)		-0.5	+7	V
I	DC current	any pin	-	50	mA
P _{tot}	total power dissipation		-	100	mW
T _{stg}	storage temperature		-55	+125	°C
T _{amb}	ambient temperature	operating in free air	-40	+85	°C
T _j	junction temperature		-	+125	°C

9. Static characteristics

Table 4. Static characteristics

$V_{CC} = 2.7\text{ V to }5.5\text{ V}$; $GND = 0\text{ V}$; $T_{amb} = -40\text{ }^{\circ}\text{C to }+85\text{ }^{\circ}\text{C}$; unless otherwise specified.

Symbol	Parameter	Conditions	Min	Typ	Max	Unit
Supplies						
V_{CCB}	supply voltage, B-side bus		2.7	-	5.5	V
V_{CCA}	supply voltage, A-side bus		[1] 0.9	-	5.5	V
$I_{CC(VCCA)}$	supply current on pin V_{CCA}		-	-	1	mA
I_{CCH}	HIGH-state supply current	both channels HIGH; $V_{CC} = 5.5\text{ V}$; $SDAn = SCLn = V_{CC}$	-	1.5	5	mA
I_{CCL}	LOW-state supply current	both channels LOW; $V_{CC} = 5.5\text{ V}$; one SDA and one SCL = GND; other SDA and SCL open	-	1.5	5	mA
I_{CCAq}	quiescent supply current in contention	$V_{CC} = 5.5\text{ V}$; $SDAn = SCLn = V_{CC}$	-	1.5	5	mA
Input and output SDAB and SCLB						
V_{IH}	HIGH-level input voltage		$0.7V_{CCB}$	-	5.5	V
V_{IL}	LOW-level input voltage		[2] -0.5	-	$+0.3V_{CCB}$	V
V_{ILc}	LOW-level input voltage contention		-0.5	0.4	-	V
V_{IK}	input clamping voltage	$I_I = -18\text{ mA}$	-	-	-1.2	V
I_{LI}	input leakage current	$V_I = 3.6\text{ V}$	-	-	± 1	μA
I_{IL}	LOW-level input current	SDA, SCL; $V_I = 0.2\text{ V}$	-	-	10	μA
V_{OL}	LOW-level output voltage	$I_{OL} = 100\text{ }\mu\text{A or }6\text{ mA}$	0.47	0.52	0.6	V
$V_{OL}-V_{ILc}$	LOW-level input voltage below output LOW-level voltage	guaranteed by design	-	-	70	mV
I_{LOH}	HIGH-level output leakage current	$V_O = 3.6\text{ V}$	-	-	10	μA
C_{io}	input/output capacitance	$V_I = 3\text{ V or }0\text{ V}$; $V_{CC} = 3.3\text{ V}$	-	6	7	pF
		$V_I = 3\text{ V or }0\text{ V}$; $V_{CC} = 0\text{ V}$	-	6	7	pF
Input and output SDAA and SCLA						
V_{IH}	HIGH-level input voltage		$0.7V_{CCA}$	-	5.5	V
V_{IL}	LOW-level input voltage		[3] -0.5	-	$+0.3V_{CCA}$	V
V_{IK}	input clamping voltage	$I_I = -18\text{ mA}$	-	-	-1.2	V
I_{LI}	input leakage current	$V_I = 3.6\text{ V}$	-	-	± 1	μA
I_{IL}	LOW-level input current	SDA, SCL; $V_I = 0.2\text{ V}$	-	-	10	μA
V_{OL}	LOW-level output voltage	$I_{OL} = 6\text{ mA}$	-	0.1	0.2	V
I_{LOH}	HIGH-level output leakage current	$V_O = 3.6\text{ V}$	-	-	10	μA
C_{io}	input/output capacitance	$V_I = 3\text{ V or }0\text{ V}$; $V_{CC} = 3.3\text{ V}$	-	6	7	pF
		$V_I = 3\text{ V or }0\text{ V}$; $V_{CC} = 0\text{ V}$	-	6	7	pF

Table 4. Static characteristics ...continued

$V_{CC} = 2.7\text{ V to }5.5\text{ V}$; $GND = 0\text{ V}$; $T_{amb} = -40\text{ }^{\circ}\text{C to }+85\text{ }^{\circ}\text{C}$; unless otherwise specified.

Symbol	Parameter	Conditions	Min	Typ	Max	Unit
Enable						
V_{IL}	LOW-level input voltage		-0.5	-	+0.3 V_{CCB}	V
V_{IH}	HIGH-level input voltage		0.7 V_{CCB}	-	5.5	V
$I_{IL(EN)}$	LOW-level input current on pin EN	$V_I = 0.2\text{ V}$, EN; $V_{CC} = 3.6\text{ V}$	-	-10	-30	μA
I_{LI}	input leakage current		-1	-	+1	μA
C_i	input capacitance	$V_I = 3.0\text{ V or }0\text{ V}$	-	6	7	pF

- [1] LOW-level supply voltage.
- [2] V_{IL} specification is for the first LOW level seen by the SDAB/SCLB lines. V_{ILc} is for the second and subsequent LOW levels seen by the SDAB/SCLB lines.
- [3] V_{IL} for A-side with envelope noise must be below 0.3 V_{CCA} for stable performance.

10. Dynamic characteristics

Table 5. Dynamic characteristics

$V_{CC} = 2.7\text{ V to }5.5\text{ V}$; $GND = 0\text{ V}$; $T_{amb} = -40\text{ }^{\circ}\text{C to }+85\text{ }^{\circ}\text{C}$; unless otherwise specified.^{[1][2]}

Symbol	Parameter	Conditions	Min	Typ ^[3]	Max	Unit
t_{PLH}	LOW-to-HIGH propagation delay	B-side to A-side; Figure 12	^[4] 100	170	250	ns
t_{PHL}	HIGH-to-LOW propagation delay	B-side to A-side; Figure 10				
		$V_{CCA} \leq 2.7\text{ V}$	^[5] 30	80	110	ns
		$V_{CCA} \geq 3\text{ V}$	10	66	300	ns
$t_{i(LH)}$	LOW-to-HIGH transition time	A-side; Figure 10	10	20	30	ns
$t_{i(HL)}$	HIGH-to-LOW transition time	A-side; Figure 10				
		$V_{CCA} \leq 2.7\text{ V}$	^[5] 1	77	105	ns
		$V_{CCA} \geq 3\text{ V}$	20	70	175	ns
t_{PLH}	LOW-to-HIGH propagation delay	A-side to B-side; Figure 11	^[6] 25	53	110	ns
t_{PHL}	HIGH-to-LOW propagation delay	A-side to B-side; Figure 11	^[6] 60	79	230	ns
$t_{i(LH)}$	LOW-to-HIGH transition time	B-side; Figure 11	120	140	170	ns
$t_{i(HL)}$	HIGH-to-LOW transition time	B-side; Figure 11	30	48	90	ns
t_{su}	set-up time	EN HIGH before START condition	^[7] 100	-	-	ns
t_h	hold time	EN HIGH after STOP condition	^[7] 100	-	-	ns

- [1] Times are specified with loads of 1.35 k Ω pull-up resistance and 57 pF load capacitance on the B-side, and 167 Ω pull-up resistance and 57 pF load capacitance on the A-side. Different load resistance and capacitance will alter the RC time constant, thereby changing the propagation delay and transition times.
- [2] Pull-up voltages are V_{CCA} on the A-side and V_{CCB} on the B-side.
- [3] Typical values were measured with $V_{CCA} = 3.3\text{ V}$ at $T_{amb} = 25\text{ }^{\circ}\text{C}$, unless otherwise noted.
- [4] The t_{PLH} delay data from B-side to A-side is measured at 0.5 V on the B-side to 0.5 V_{CCA} on the A-side when V_{CCA} is less than 2 V, and 1.5 V on the A-side if V_{CCA} is greater than 2 V.
- [5] Typical value measured with $V_{CCA} = 2.7\text{ V}$ at $T_{amb} = 25\text{ }^{\circ}\text{C}$.
- [6] The proportional delay data from A-side to B-side is measured at 0.3 V_{CCA} on the A-side to 1.5 V on the B-side.
- [7] The enable pin, EN, should only change state when the global bus and the repeater port are in an idle state.

10.1 AC waveforms

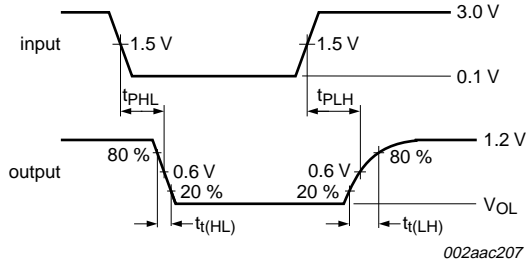

Fig 10. Propagation delay and transition times; B-side to A-side

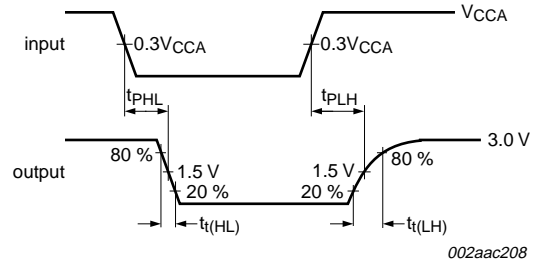

Fig 11. Propagation delay and transition times; A-side to B-side

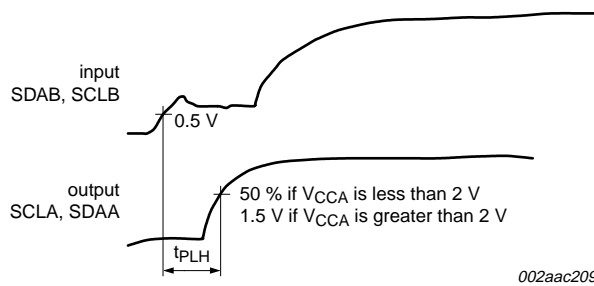
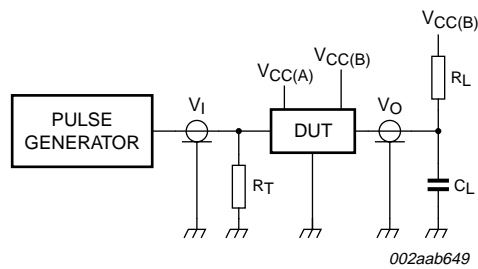

Fig 12. Propagation delay

11. Test information



R_L = load resistor; 1.35 k Ω on B-side; 167 Ω on A-side (0.9 V to 2.7 V) and 450 Ω on A-side (3.0 V to 5.5 V).

C_L = load capacitance includes jig and probe capacitance; 57 pF

R_T = termination resistance should be equal to Z_o of pulse generators

Fig 13. Test circuit for open-drain outputs

12. Package outline

SO8: plastic small outline package; 8 leads; body width 3.9 mm

SOT96-1

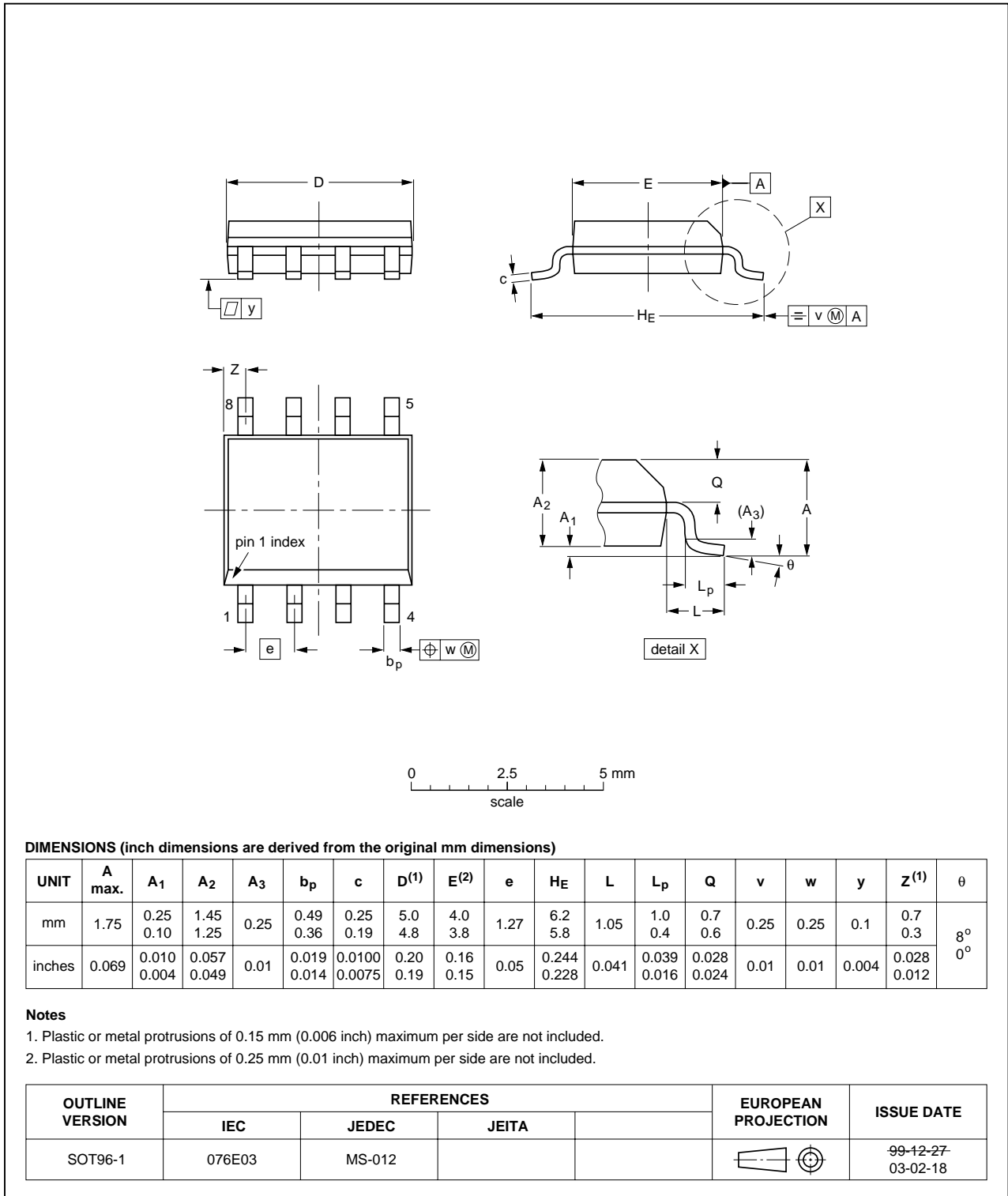

Fig 14. Package outline SOT96-1 (SO8)

TSSOP8: plastic thin shrink small outline package; 8 leads; body width 3 mm

SOT505-1

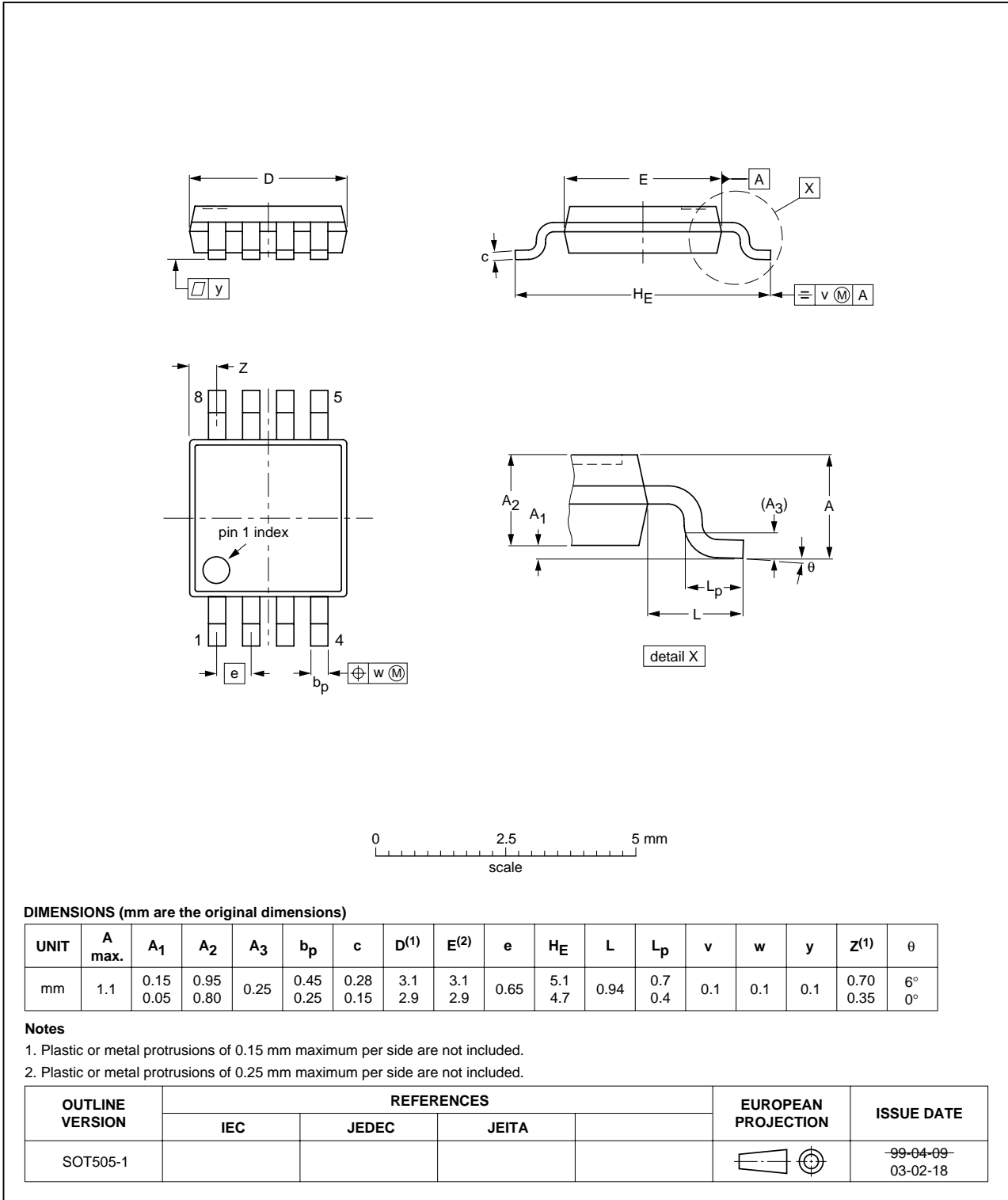

Fig 15. Package outline SOT505-1 (TSSOP8)

13. Soldering

This text provides a very brief insight into a complex technology. A more in-depth account of soldering ICs can be found in Application Note *AN10365 "Surface mount reflow soldering description"*.

13.1 Introduction to soldering

Soldering is one of the most common methods through which packages are attached to Printed Circuit Boards (PCBs), to form electrical circuits. The soldered joint provides both the mechanical and the electrical connection. There is no single soldering method that is ideal for all IC packages. Wave soldering is often preferred when through-hole and Surface Mount Devices (SMDs) are mixed on one printed wiring board; however, it is not suitable for fine pitch SMDs. Reflow soldering is ideal for the small pitches and high densities that come with increased miniaturization.

13.2 Wave and reflow soldering

Wave soldering is a joining technology in which the joints are made by solder coming from a standing wave of liquid solder. The wave soldering process is suitable for the following:

- Through-hole components
- Leaded or leadless SMDs, which are glued to the surface of the printed circuit board

Not all SMDs can be wave soldered. Packages with solder balls, and some leadless packages which have solder lands underneath the body, cannot be wave soldered. Also, leaded SMDs with leads having a pitch smaller than ~0.6 mm cannot be wave soldered, due to an increased probability of bridging.

The reflow soldering process involves applying solder paste to a board, followed by component placement and exposure to a temperature profile. Leaded packages, packages with solder balls, and leadless packages are all reflow solderable.

Key characteristics in both wave and reflow soldering are:

- Board specifications, including the board finish, solder masks and vias
- Package footprints, including solder thieves and orientation
- The moisture sensitivity level of the packages
- Package placement
- Inspection and repair
- Lead-free soldering versus PbSn soldering

13.3 Wave soldering

Key characteristics in wave soldering are:

- Process issues, such as application of adhesive and flux, clinching of leads, board transport, the solder wave parameters, and the time during which components are exposed to the wave
- Solder bath specifications, including temperature and impurities

13.4 Reflow soldering

Key characteristics in reflow soldering are:

- Lead-free versus SnPb soldering; note that a lead-free reflow process usually leads to higher minimum peak temperatures (see [Figure 16](#)) than a PbSn process, thus reducing the process window
- Solder paste printing issues including smearing, release, and adjusting the process window for a mix of large and small components on one board
- Reflow temperature profile; this profile includes preheat, reflow (in which the board is heated to the peak temperature) and cooling down. It is imperative that the peak temperature is high enough for the solder to make reliable solder joints (a solder paste characteristic). In addition, the peak temperature must be low enough that the packages and/or boards are not damaged. The peak temperature of the package depends on package thickness and volume and is classified in accordance with [Table 6](#) and [7](#)

Table 6. SnPb eutectic process (from J-STD-020C)

Package thickness (mm)	Package reflow temperature (°C)	
	Volume (mm ³)	
	< 350	≥ 350
< 2.5	235	220
≥ 2.5	220	220

Table 7. Lead-free process (from J-STD-020C)

Package thickness (mm)	Package reflow temperature (°C)		
	Volume (mm ³)		
	< 350	350 to 2000	> 2000
< 1.6	260	260	260
1.6 to 2.5	260	250	245
> 2.5	250	245	245

Moisture sensitivity precautions, as indicated on the packing, must be respected at all times.

Studies have shown that small packages reach higher temperatures during reflow soldering, see [Figure 16](#).

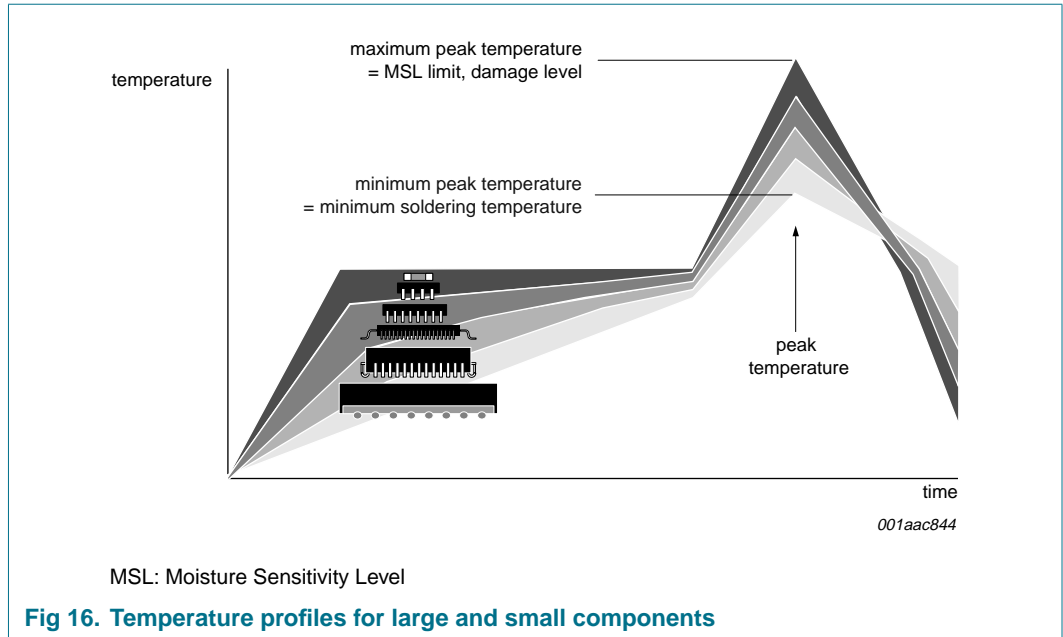

For further information on temperature profiles, refer to Application Note AN10365 “Surface mount reflow soldering description”.

14. Abbreviations

Table 8. Abbreviations

Acronym	Description
CDM	Charged Device Model
CMOS	Complementary Metal Oxide Silicon
ESD	ElectroStatic Discharge
HBM	Human Body Model
I ² C-bus	Inter Integrated Circuit bus
MM	Machine Model
SMBus	System Management Bus

15. Revision history

Table 9. Revision history

Document ID	Release date	Data sheet status	Change notice	Supersedes
PCA9517_3	20070130	Product data sheet	-	PCA9517_2
Modifications:	<ul style="list-style-type: none"> • The format of this data sheet has been redesigned to comply with the new identity guidelines of NXP Semiconductors. • Legal texts have been adapted to the new company name where appropriate. • Section 2 “Features”, 15th bullet item: changed “200 V MM per JESD22-A115” to “150 V MM per JESD22-A115” • Table 4 “Static characteristics” added new Table note 3, and its reference in sub-section “Input and output SDAA and SCLA”, symbol V_{IL}. • added (new) Figure 7 “Typical application of PCA9517 driving a short cable” • Figure 8 “Bus A (0.9 V to 5.5 V bus) waveform”: SDA signal modified • Figure 9 “Bus B (2.7 V to 5.5 V) waveform”: SDA signal modified • Table 5 “Dynamic characteristics”: <ul style="list-style-type: none"> – $t_{t(LH)}$, A-side: changed reference to timing diagram from Figure 11 to Figure 10 – $t_{t(HL)}$, A-side: changed reference to timing diagram from Figure 11 to Figure 10 – $t_{t(LH)}$, B-side: changed reference to timing diagram from Figure 10 to Figure 11 – $t_{t(HL)}$, B-side: changed reference to timing diagram from Figure 10 to Figure 11 			
PCA9517_2 (9397 750 14918)	20060615	Product data sheet	-	PCA9517_1
PCA9517_1 (9397 750 13252)	20041005	Product data sheet	-	-

16. Legal information

16.1 Data sheet status

Document status ^{[1][2]}	Product status ^[3]	Definition
Objective [short] data sheet	Development	This document contains data from the objective specification for product development.
Preliminary [short] data sheet	Qualification	This document contains data from the preliminary specification.
Product [short] data sheet	Production	This document contains the product specification.

[1] Please consult the most recently issued document before initiating or completing a design.

[2] The term 'short data sheet' is explained in section "Definitions".

[3] The product status of device(s) described in this document may have changed since this document was published and may differ in case of multiple devices. The latest product status information is available on the Internet at URL <http://www.nxp.com>.

16.2 Definitions

Draft — The document is a draft version only. The content is still under internal review and subject to formal approval, which may result in modifications or additions. NXP Semiconductors does not give any representations or warranties as to the accuracy or completeness of information included herein and shall have no liability for the consequences of use of such information.

Short data sheet — A short data sheet is an extract from a full data sheet with the same product type number(s) and title. A short data sheet is intended for quick reference only and should not be relied upon to contain detailed and full information. For detailed and full information see the relevant full data sheet, which is available on request via the local NXP Semiconductors sales office. In case of any inconsistency or conflict with the short data sheet, the full data sheet shall prevail.

16.3 Disclaimers

General — Information in this document is believed to be accurate and reliable. However, NXP Semiconductors does not give any representations or warranties, expressed or implied, as to the accuracy or completeness of such information and shall have no liability for the consequences of use of such information.

Right to make changes — NXP Semiconductors reserves the right to make changes to information published in this document, including without limitation specifications and product descriptions, at any time and without notice. This document supersedes and replaces all information supplied prior to the publication hereof.

Suitability for use — NXP Semiconductors products are not designed, authorized or warranted to be suitable for use in medical, military, aircraft, space or life support equipment, nor in applications where failure or malfunction of a NXP Semiconductors product can reasonably be expected to

result in personal injury, death or severe property or environmental damage. NXP Semiconductors accepts no liability for inclusion and/or use of NXP Semiconductors products in such equipment or applications and therefore such inclusion and/or use is at the customer's own risk.

Applications — Applications that are described herein for any of these products are for illustrative purposes only. NXP Semiconductors makes no representation or warranty that such applications will be suitable for the specified use without further testing or modification.

Limiting values — Stress above one or more limiting values (as defined in the Absolute Maximum Ratings System of IEC 60134) may cause permanent damage to the device. Limiting values are stress ratings only and operation of the device at these or any other conditions above those given in the Characteristics sections of this document is not implied. Exposure to limiting values for extended periods may affect device reliability.

Terms and conditions of sale — NXP Semiconductors products are sold subject to the general terms and conditions of commercial sale, as published at <http://www.nxp.com/profile/terms>, including those pertaining to warranty, intellectual property rights infringement and limitation of liability, unless explicitly otherwise agreed to in writing by NXP Semiconductors. In case of any inconsistency or conflict between information in this document and such terms and conditions, the latter will prevail.

No offer to sell or license — Nothing in this document may be interpreted or construed as an offer to sell products that is open for acceptance or the grant, conveyance or implication of any license under any copyrights, patents or other industrial or intellectual property rights.

16.4 Trademarks

Notice: All referenced brands, product names, service names and trademarks are the property of their respective owners.

I²C-bus — logo is a trademark of NXP B.V.

17. Contact information

For additional information, please visit: <http://www.nxp.com>

For sales office addresses, send an email to: salesaddresses@nxp.com

18. Contents

1	General description	1
2	Features	1
3	Ordering information	2
4	Functional diagram	2
5	Pinning information	3
5.1	Pinning	3
5.2	Pin description	3
6	Functional description	3
6.1	Enable	4
6.2	I ² C-bus systems	4
7	Application design-in information	5
8	Limiting values	8
9	Static characteristics	9
10	Dynamic characteristics	10
10.1	AC waveforms	11
11	Test information	11
12	Package outline	12
13	Soldering	14
13.1	Introduction to soldering	14
13.2	Wave and reflow soldering	14
13.3	Wave soldering	14
13.4	Reflow soldering	15
14	Abbreviations	16
15	Revision history	17
16	Legal information	18
16.1	Data sheet status	18
16.2	Definitions	18
16.3	Disclaimers	18
16.4	Trademarks	18
17	Contact information	18
18	Contents	19

Please be aware that important notices concerning this document and the product(s) described herein, have been included in section 'Legal information'.

founded by

PHILIPS

© NXP B.V. 2007.

All rights reserved.

For more information, please visit: <http://www.nxp.com>

For sales office addresses, please send an email to: salesaddresses@nxp.com

Date of release: 30 January 2007

Document identifier: PCA9517_3

Mouser Electronics

Authorized Distributor

Click to View Pricing, Inventory, Delivery & Lifecycle Information:

[NXP:](#)

[PCA9517D,112](#) [PCA9517DP,118](#) [PCA9517D,118](#) [PCA9517D](#)

Данный компонент на территории Российской Федерации

Вы можете приобрести в компании MosChip.

Для оперативного оформления запроса Вам необходимо перейти по данной ссылке:

<http://moschip.ru/get-element>

Вы можете разместить у нас заказ для любого Вашего проекта, будь то серийное производство или разработка единичного прибора.

В нашем ассортименте представлены ведущие мировые производители активных и пассивных электронных компонентов.

Нашей специализацией является поставка электронной компонентной базы двойного назначения, продукции таких производителей как XILINX, Intel (ex.ALTERA), Vicor, Microchip, Texas Instruments, Analog Devices, Mini-Circuits, Amphenol, Glenair.

Сотрудничество с глобальными дистрибьюторами электронных компонентов, предоставляет возможность заказывать и получать с международных складов практически любой перечень компонентов в оптимальные для Вас сроки.

На всех этапах разработки и производства наши партнеры могут получить квалифицированную поддержку опытных инженеров.

Система менеджмента качества компании отвечает требованиям в соответствии с ГОСТ Р ИСО 9001, ГОСТ РВ 0015-002 и ЭС РД 009

Офис по работе с юридическими лицами:

105318, г.Москва, ул.Щербаковская д.3, офис 1107, 1118, ДЦ «Щербаковский»

Телефон: +7 495 668-12-70 (многоканальный)

Факс: +7 495 668-12-70 (доб.304)

E-mail: info@moschip.ru

Skype отдела продаж:

moschip.ru

moschip.ru_4

moschip.ru_6

moschip.ru_9