

NEW



ES10 Series

CONNECTOR

MB-0274-1

January 2014

RoHS Compliant

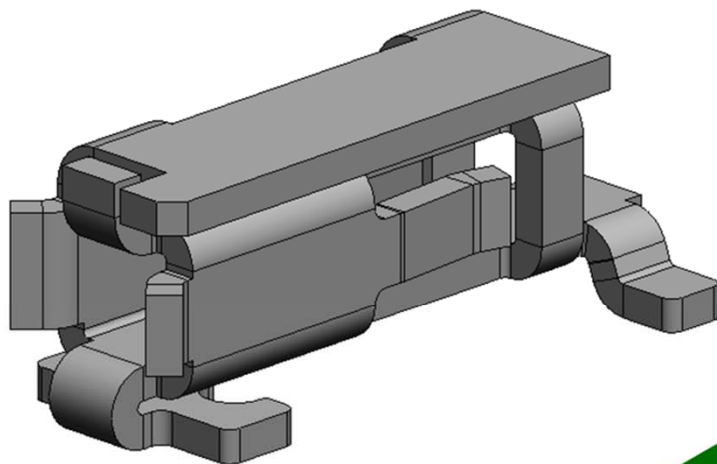

[When cable is inserted]

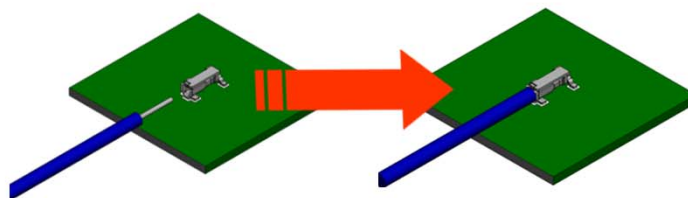

<<Outline>>

The ES10 Series is a compact, low-profile single wire cable insertion type connector without an insulator compatible with LED lighting equipment. It can be used for a wide range of various compact devices such as liquid crystal TV backlight, tablet PC, and others.

Features

- Compact and low-profile structure without an insulator enhances design flexibility for customers.
- Just need to insert the stripped wire into the connector for connection.
- Improved insertion workability with a guiding mechanism at the single wire insertion area.
- Improved contact reliability with an original spring contacting structure.
- Available in embossed tape reel packaging for automated mounting.

General Specifications

- | | |
|---------------------------------|--|
| ■ No. of Contacts: 1 pin | ■ Durability: 5 times |
| ■ Contact Resistance: 30mΩ max. | ■ Operating Temperature:
-40 Deg. C to +105 Deg. C |
| ■ Rated Current: AC/DC 2A | ■ Applicable Wire:
Single wire 26 to 24 AWG equivalent
(φ0.4mm to φ0.51mm)
Covered diameter φ2.0mm max. (recommended) |

* twisted wire (including spare solder) can not be used

Materials and Finishes

Component	Material and Finish
Contact	Copper alloy / Sn plating

Ordering Information

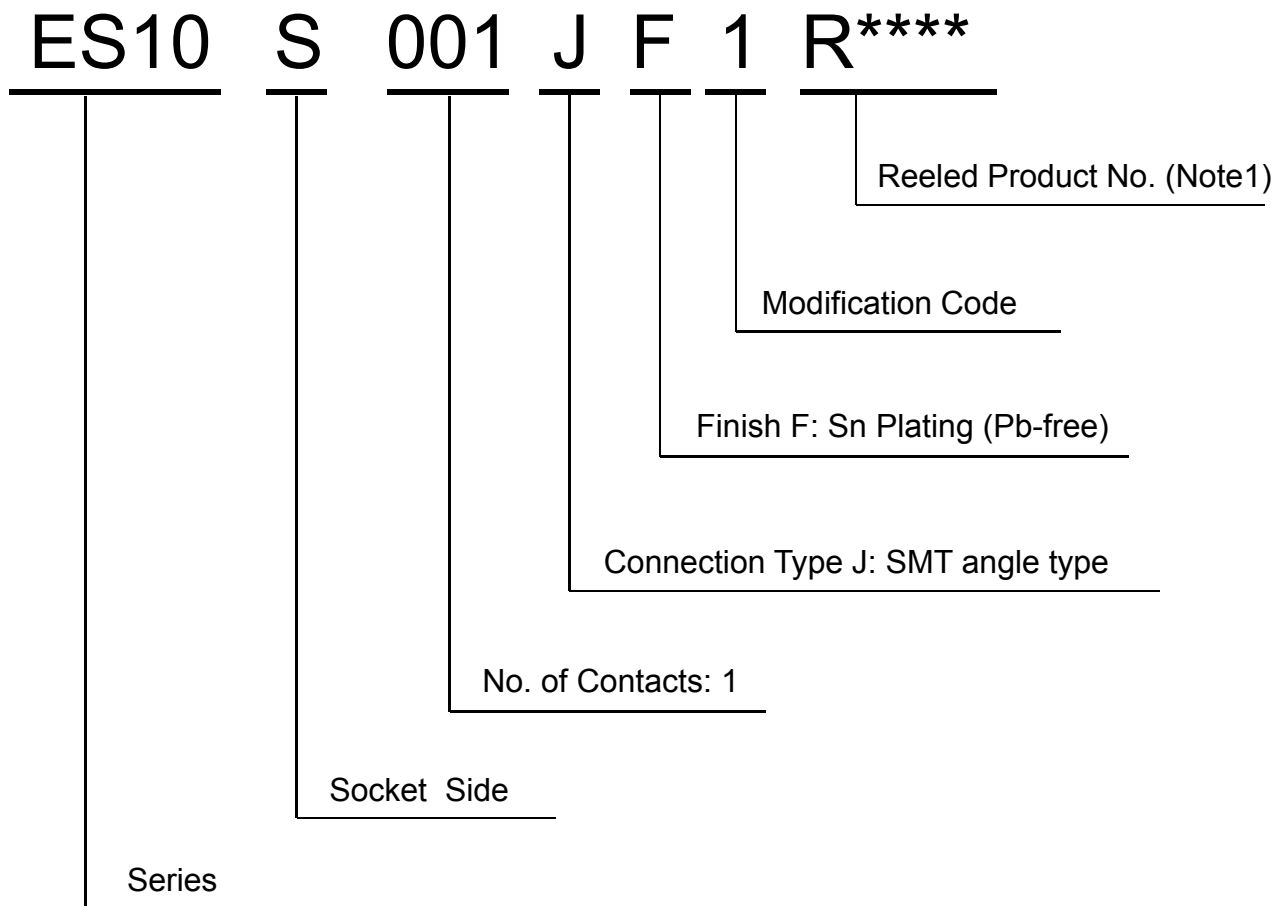

Note 1: An embossed tape reel contains 4,500 pieces.

Part Number	ES10S001JF1
Drawing No.	SJ113985

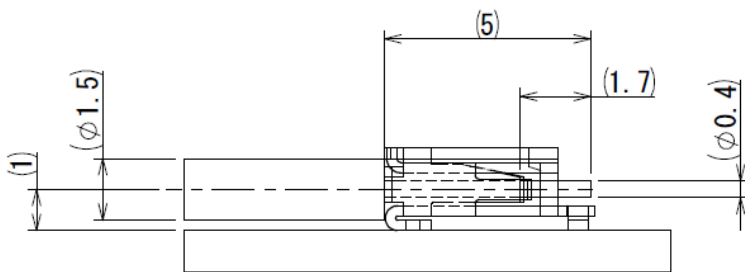
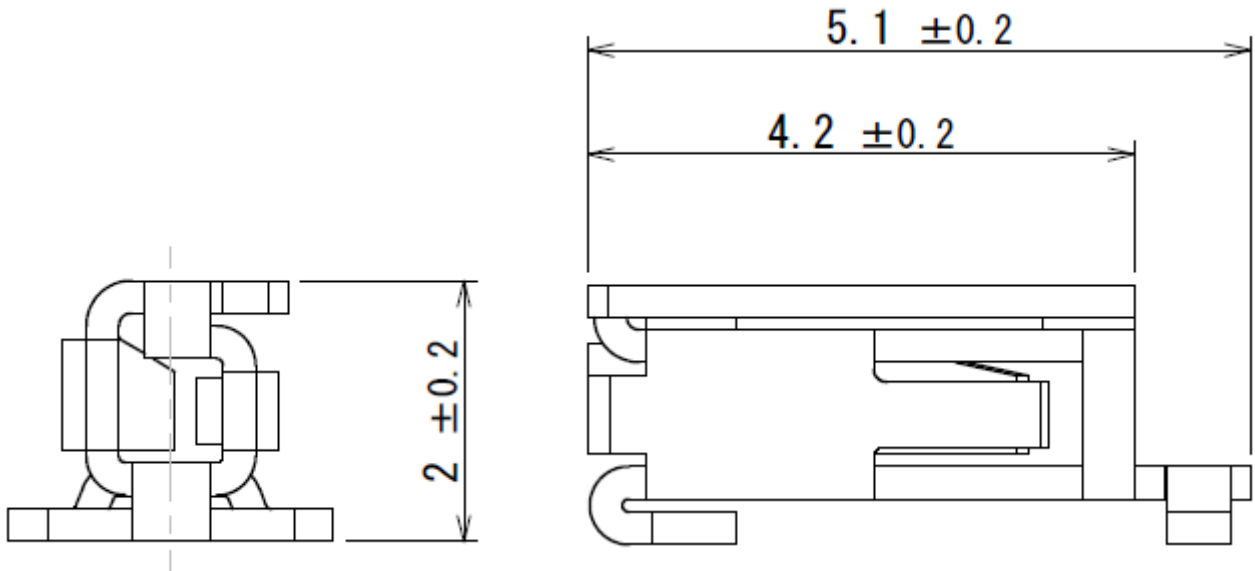

MATED CONDITION (REF.)

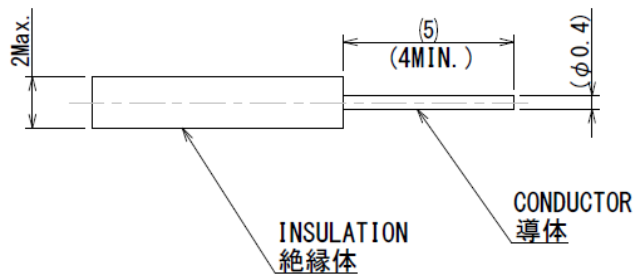

Note 1: Applicable cable (conductor): single wire 26AWG (0.4 Dia.)
 Applicable cable (insulator): 2.0 Dia. max. *Please contact us regarding other sizes.
 Note 2: Twisted wire can not be used.

1	CONNECTOR	1	COPPER ALLOY	LEAD-FREE TIN PLATING
符号 NO.	名称 DESCRIPTION	個数 QTY.	材料 MATERIAL	仕上 FINISH

Part Number	ES10S001JF1R4500
Drawing No.	SJ113986

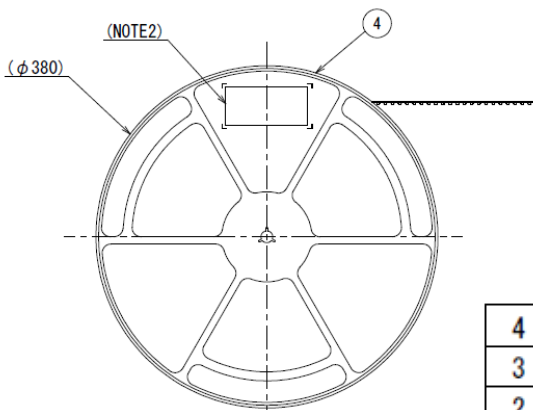
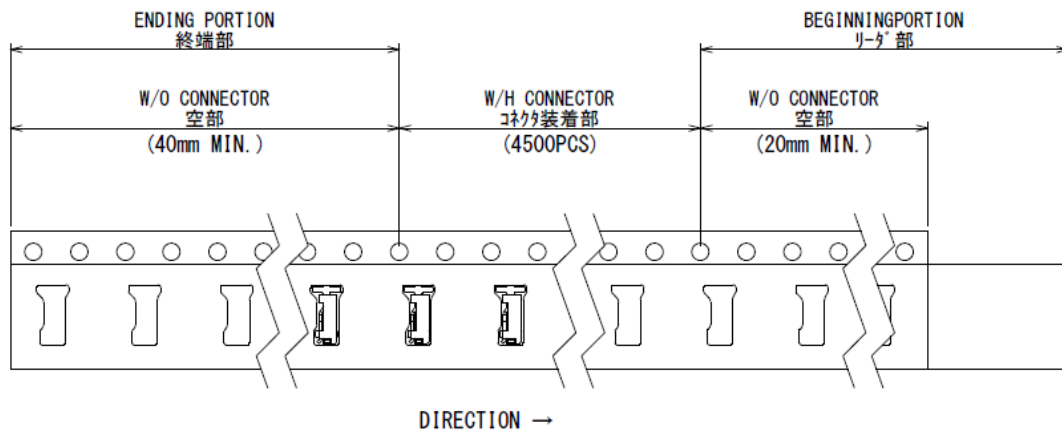
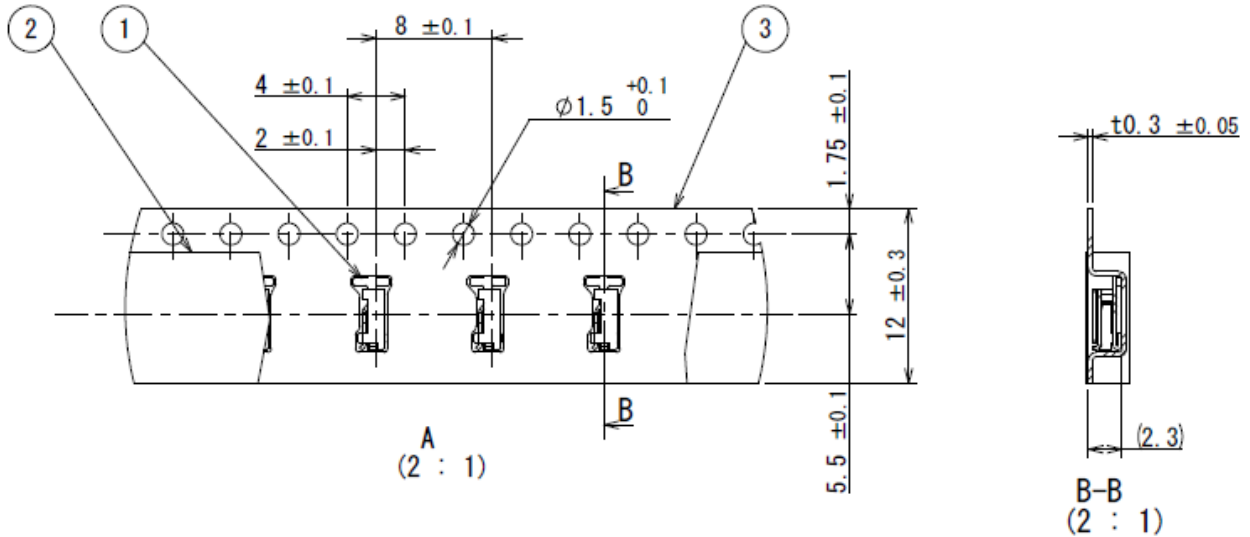

4	REEL	1	POLYSTYRENE
3	CARRIER TAPE	1	POLYSTYRENE
2	COVER TAPE	1	POLYESTER
1	CONNECTOR	4500	
符号 NO.	名 称 DESCRIPTION	個 数 QTY.	材 料 MATERIAL

<Applicable Board Dimensions>

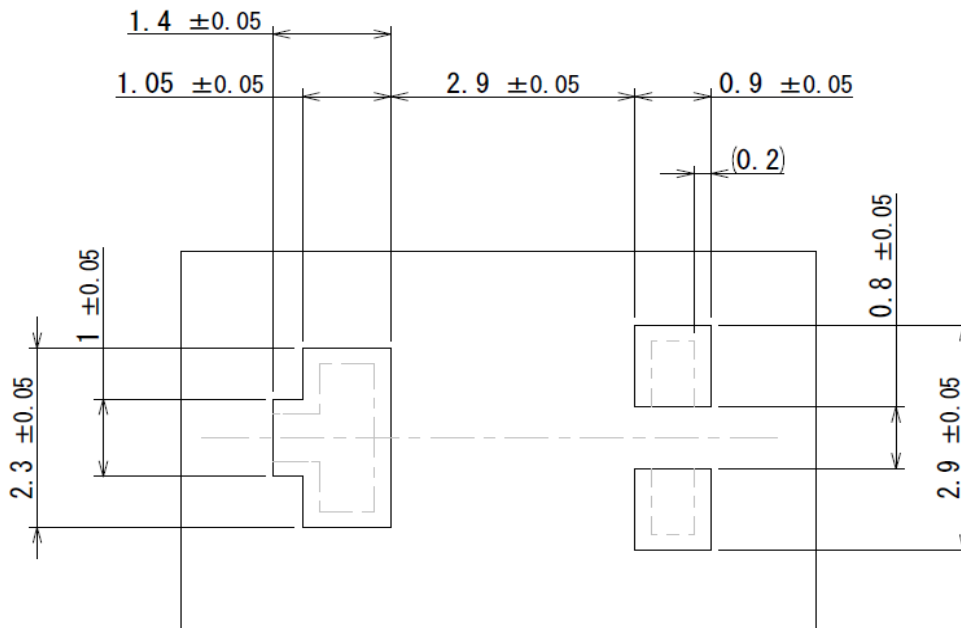

Technical Documents

	Technical Document No. (Content of documents)
Product Drawings	SJ113985 (ES10S001JF1 individual product) SJ113986 (ES10S001JF1 embossed packaging product)
Specifications	JACS-10984
Handling Instructions	JAHL-10984

Notice:

1. The values specified in this brochure are only for reference. The products and their specifications are subject to change without notice. Contact our sales staff for further information before considering or ordering any of our products. For purchase, a product specification must be agreed upon.

2. Users are requested to provide protection circuits and redundancy circuits to ensure safety of the equipment, and sufficiently review the suitability of JAE's products to the equipment.

3. The products presented in this brochure are designed for the uses recommended below. We strongly suggest you contact our sales staff when considering use of any of the products in any other way than the recommended applications or for a specific use that requires an extremely high reliability.

(1) Applications that require consultation:

(i) Please contact us if you are considering use involving a quality assurance program that you specify or that is peculiar to the industry, such as:

Automotive electrical components, train control, telecommunications devices (mainline), traffic light control, electric power, combustion control, fire prevention or security systems, disaster prevention equipment, etc.

(ii) We may separately give you our support with a quality assurance program that you specify, when you think of a use such as :

Aviation or space equipment, submarine repeaters, nuclear power control systems, medical equipment for life support, etc.

(2) Recommended applications include:

Computers, office appliances, telecommunications devices (terminals, mobile units), measuring equipment, audiovisual equipment, home electric appliances, factory automation equipment, etc

Japan Aviation Electronics Industry, Limited

Product Marketing Division

Aobadai Building, 3-1-19, Aobadai, Meguro-ku, Tokyo 153-8539

Phone: +81-3-3780-2882 FAX: +81-3-3780-2946

* The specifications in this brochure are subject to change without notice. Please contact JAE for information.

Данный компонент на территории Российской Федерации

Вы можете приобрести в компании MosChip.

Для оперативного оформления запроса Вам необходимо перейти по данной ссылке:

<http://moschip.ru/get-element>

Вы можете разместить у нас заказ для любого Вашего проекта, будь то серийное производство или разработка единичного прибора.

В нашем ассортименте представлены ведущие мировые производители активных и пассивных электронных компонентов.

Нашей специализацией является поставка электронной компонентной базы двойного назначения, продукции таких производителей как XILINX, Intel (ex.ALTERA), Vicor, Microchip, Texas Instruments, Analog Devices, Mini-Circuits, Amphenol, Glenair.

Сотрудничество с глобальными дистрибьюторами электронных компонентов, предоставляет возможность заказывать и получать с международных складов практически любой перечень компонентов в оптимальные для Вас сроки.

На всех этапах разработки и производства наши партнеры могут получить квалифицированную поддержку опытных инженеров.

Система менеджмента качества компании отвечает требованиям в соответствии с ГОСТ Р ИСО 9001, ГОСТ РВ 0015-002 и ЭС РД 009

Офис по работе с юридическими лицами:

105318, г.Москва, ул.Щербаковская д.3, офис 1107, 1118, ДЦ «Щербаковский»

Телефон: +7 495 668-12-70 (многоканальный)

Факс: +7 495 668-12-70 (доб.304)

E-mail: info@moschip.ru

Skype отдела продаж:

moschip.ru

moschip.ru_4

moschip.ru_6

moschip.ru_9