

THIS DRAWING IS UNPUBLISHED. RELEASED FOR PUBLICATION  
 © COPYRIGHT copyright.d8Te- ALL RIGHTS RESERVED.

REVISIONS				
P	LTR	DESCRIPTION	DATE	APVD
	A	RELEASED FOR PRODUCTION	23OCT2017	RK PO

NOTES:

- ① LID NOT ASSEMBLED WITH LOWER PART. ENCLOSED LOOSELY
- ② FLAP NOT ASSEMBLED WITH LOWER PART. ENCLOSED LOOSELY
- ③ PART NUMBER.
- ④ PRODUCTION DATE (YYMMDD)
- ⑤ MANUFACTURING LOCATION CODE.
- ⑥ FOIL CLIP INSTALLED ON BOX CONTACT RAILS
- ⑦ MODEL CODE ACCORDING TE-SPEC. 404-74000-1
- ⑧ CONSECUTIVE SERIAL NUMBER
- ⑨ TEST EQUIPMENT NUMBER
- ⑩ DIODES WELDED ON CONTACT RAIL.
- 11. MUST COMPLY WITH DIRECTIVE 2002/95/EC (ROHS).
- 12. THIS PRODUCT HAS NOT COMPLETED VALIDATION TESTING.

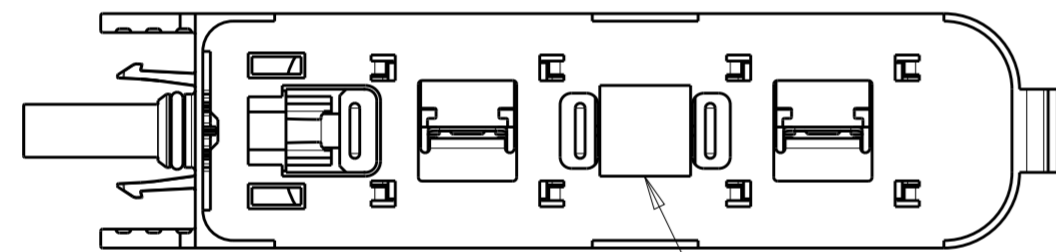
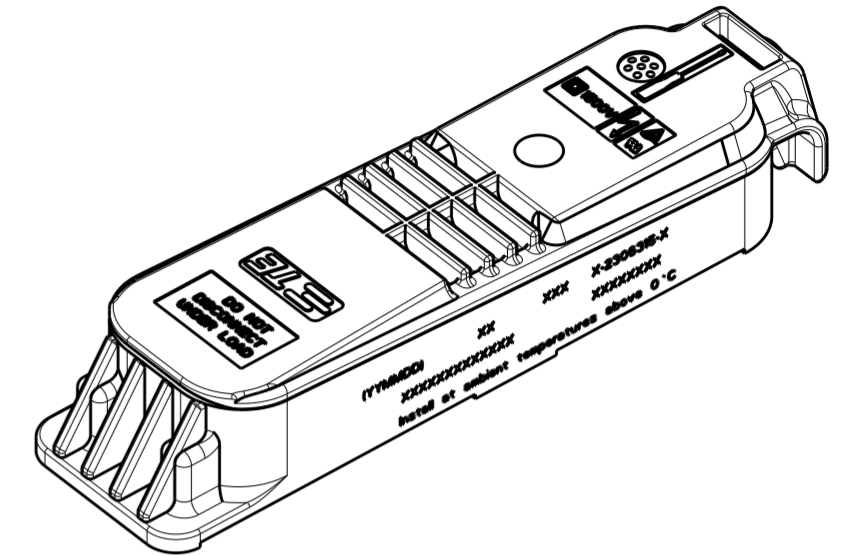
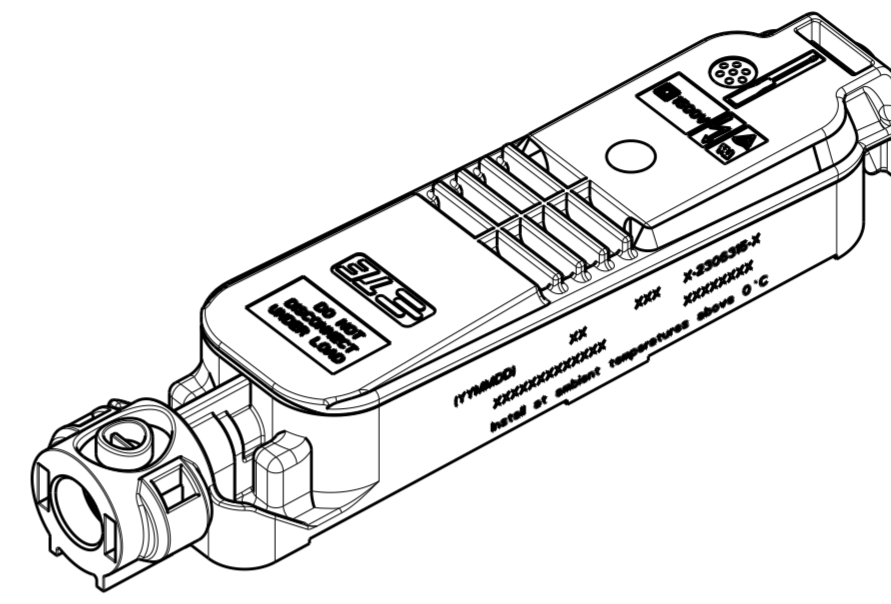
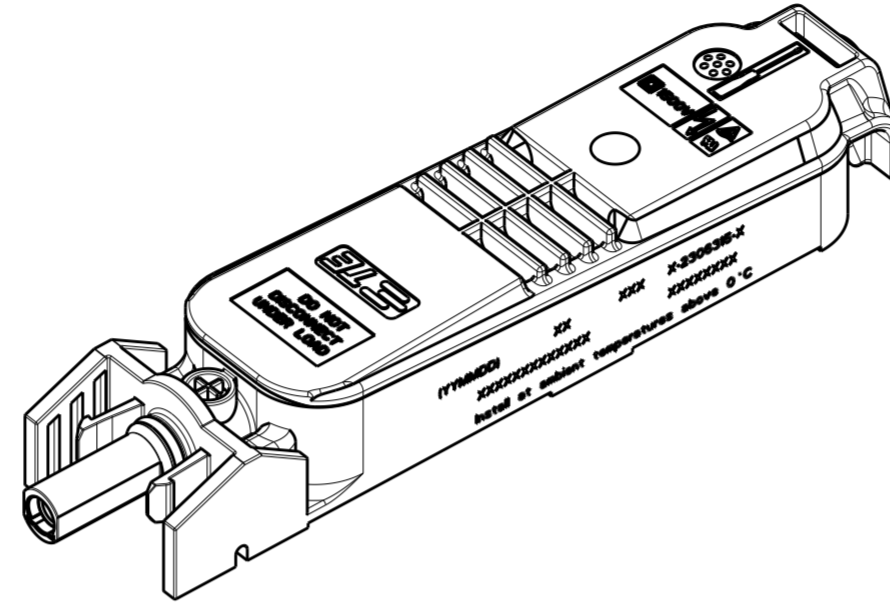

MOUNTING TAPE

BOTTOM VIEW OF TYPICAL ASSEMBLY WHEN MOUNTING TAPE IS APPLIED

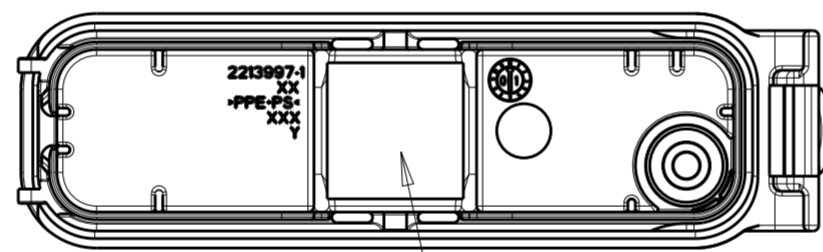

THERMAL INTERFACE MATERIAL

BOTTOM VIEW OF LID SUBASSEMBLY WHEN THERMAL INTERFACE MATERIAL IS APPLIED

PVEDGE2GGA1V_2	36.0	EAST/WEST	YES	YES	7-2306315-5
PVEDGE2DGA1V_2	55.2	EAST/WEST	YES	YES	7-2306315-2
PVEDGE2FGA1V_2	58.7	EAST/WEST	YES	YES	7-2306315-1
PVEDGE2GGA1V_2	36.0	EAST/WEST	NO	YES	6-2306315-5
PVEDGE2DGA1V_2	55.2	EAST/WEST	NO	YES	6-2306315-2
PVEDGE2FGA1V_2	58.7	EAST/WEST	NO	YES	6-2306315-1
PVEDGE2DGA1T_2	36.0	EAST/WEST	YES	NO	5-2306315-5
PVEDGE2DGA1T_2	55.2	EAST/WEST	YES	NO	5-2306315-2
PVEDGE2FGA1T_2	58.7	EAST/WEST	YES	NO	5-2306315-1
PVEDGE2GGA1T_2	36.0	EAST/WEST	NO	NO	4-2306315-5
PVEDGE2DGA1T_2	55.2	EAST/WEST	NO	NO	4-2306315-2
PVEDGE2FGA1T_2	58.7	EAST/WEST	NO	NO	4-2306315-1
PVEDGE2GGA1V_2	36.0	NORTH/SOUTH	YES	YES	3-2306315-5
PVEDGE2DGA1V_2	55.2	NORTH/SOUTH	YES	YES	3-2306315-2
PVEDGE2FGA1V_2	58.7	NORTH/SOUTH	YES	YES	3-2306315-1
PVEDGE2GGA1V_2	36.0	NORTH/SOUTH	NO	YES	2-2306315-5
PVEDGE2DGA1V_2	55.2	NORTH/SOUTH	NO	YES	2-2306315-2
PVEDGE2FGA1V_2	58.7	NORTH/SOUTH	NO	YES	2-2306315-1
PVEDGE2GGA1T_2	36.0	NORTH/SOUTH	YES	NO	1-2306315-5
PVEDGE2DGA1T_2	55.2	NORTH/SOUTH	YES	NO	1-2306315-2
PVEDGE2FGA1T_2	58.7	NORTH/SOUTH	YES	NO	1-2306315-1
PVEDGE2GGA1T_2	36.0	NORTH/SOUTH	NO	NO	2306315-5
PVEDGE2DGA1T_2	55.2	NORTH/SOUTH	NO	NO	2306315-2
PVEDGE2FGA1T_2	58.7	NORTH/SOUTH	NO	NO	2306315-1
MODEL CODE ⑦	DIM X	PV PANEL FOIL DIRECTION	MOUNTING TAPE	THERMAL INTERFACE MATERIAL	PART NO.

TIN OVER NICKEL	COPPER ALLOY	INTERFACE CONTACT-SOCKET	11
TIN OVER NICKEL	COPPER ALLOY	INTERFACE CONTACT-PIN	10
-	-	THERMAL INTERFACE MATERIAL	9
-	-	BYPASS DIODE: TYPE SL2020A	8
GRAY	PPE+PS	MEMBRANE RETAINER	7
-	-	MEMBRANE VENT	6
PLAIN	STAINLESS STEEL	FOIL CLIP	5 ⑥
TIN	COPPER ALLOY	CONTACT RAIL	4
BLACK	PPE+PS	BOX, LOWER HOUSING	3
RED	SILICONE	O-RING SEAL	2
BLACK	PPE+PS	BOX, LID	1 ①
COLOR/FINISH	MATERIAL	DESCRIPTION	ITEM NO.

THIS DRAWING IS A CONTROLLED DOCUMENT.

DIMENSIONS: mm	TOLERANCES UNLESS OTHERWISE SPECIFIED: 0 PLC ±0.50 1 PLC ±0.25 2 PLC ±0.13 3 PLC ± 4 PLC ± ANGLES ± FINISH	DWN RAVLS 12AUG2016	TE Connectivity
		CHK GINGRICH CHUCK 12AUG2016	
		APVD GINGRICH CHUCK 12AUG2016	NAME PV EDGE ASSEMBLY, WITHOUT FLAP, S CLIP
		PRODUCT SPEC 108-32122	SIZE A2
MATERIAL ①		APPLICATION SPEC 114-32157	CAGE CODE -
		WEIGHT -	DRAWING NO. C-2306315
		CUSTOMER DRAWING	RESTRICTED TO -

SCALE 1:1 SHEET 1 OF 4 REV A

THIS DRAWING IS UNPUBLISHED. RELEASED FOR PUBLICATION  
 © COPYRIGHT copyright.d8Te- ALL RIGHTS RESERVED.

REVISIONS				
P	LTR	DESCRIPTION	DATE	APVD
-		SEE SHEET 1	-	-

LID NOT SHOWN FOR REFERENCE ONLY

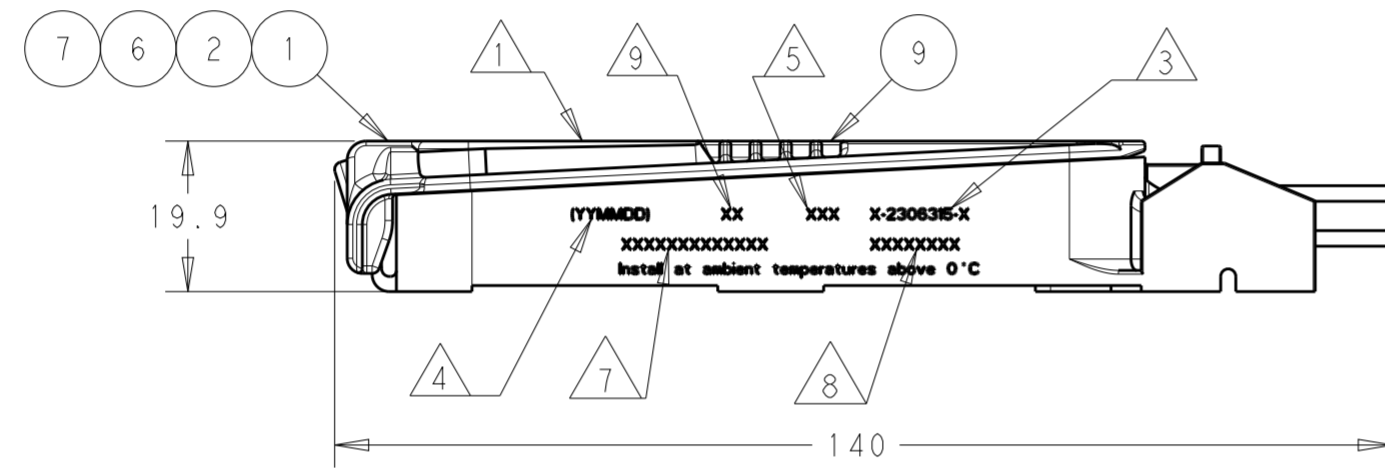
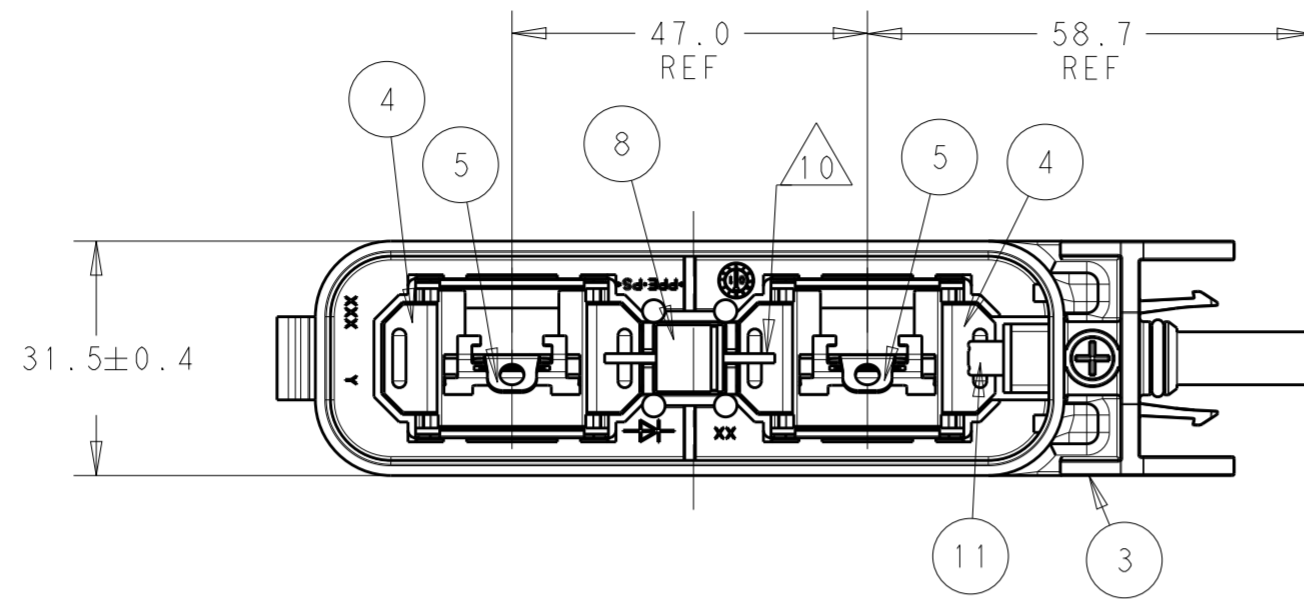

NORTH-SOUTH VERSIONS  
 2306315-1  
 1-2306315-1  
 2-2306315-1  
 3-2306315-1  
 SHOWN

LID NOT SHOWN FOR REFERENCE ONLY

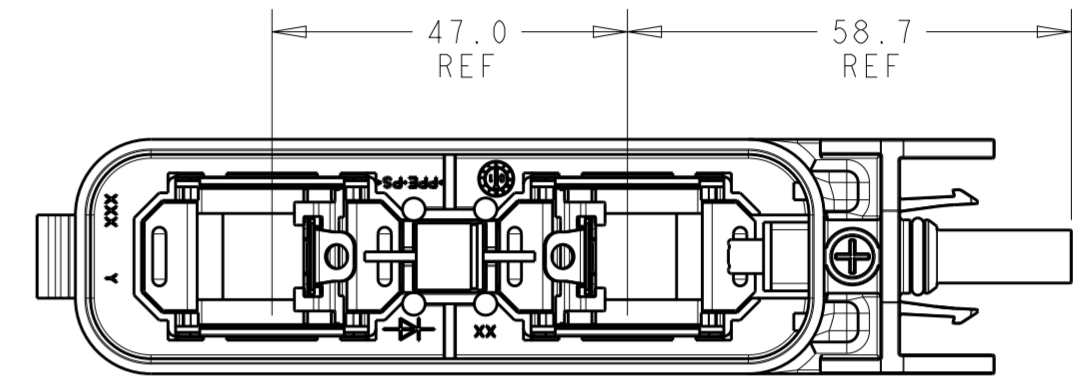

EAST-WEST VERSIONS  
 4-2306315-1  
 5-2306315-1  
 6-2306315-1  
 7-2306315-1  
 SAME AS N-S VERSIONS  
 EXCEPT AS SHOWN

LID NOT SHOWN FOR REFERENCE ONLY

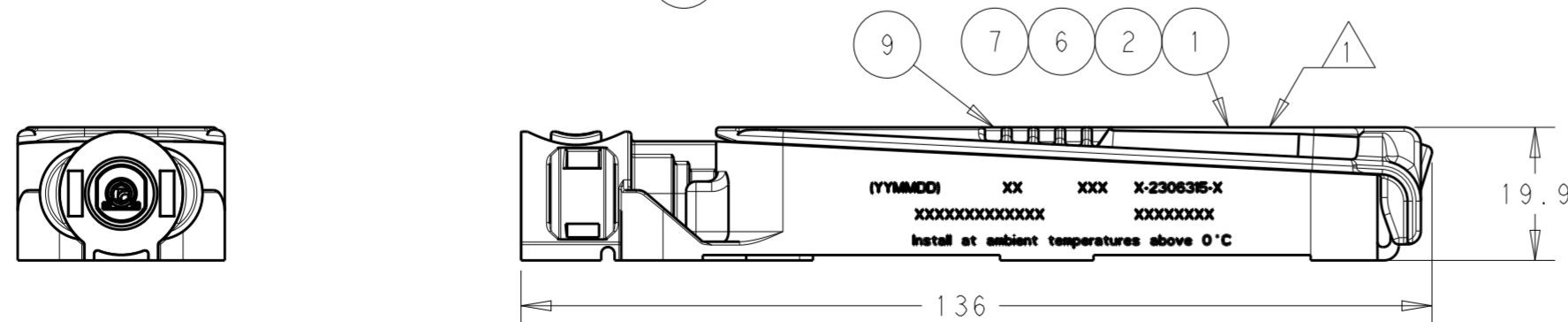
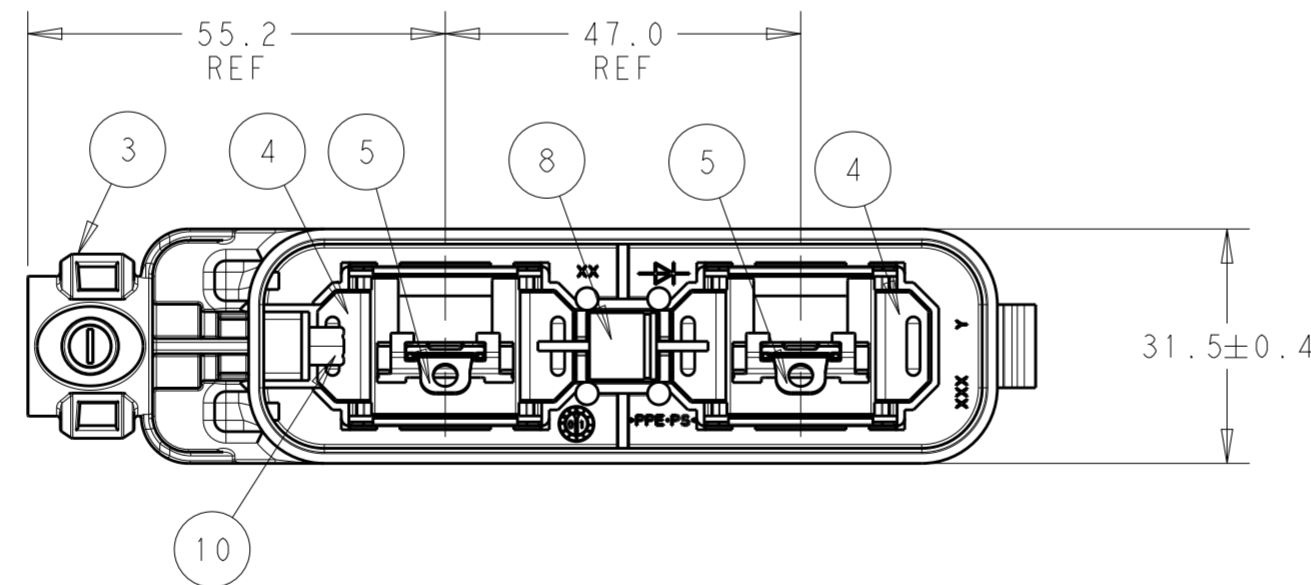

NORTH-SOUTH VERSIONS  
 2306315-2  
 1-2306315-2  
 2-2306315-2  
 3-2306315-2  
 SHOWN

LID NOT SHOWN FOR REFERENCE ONLY

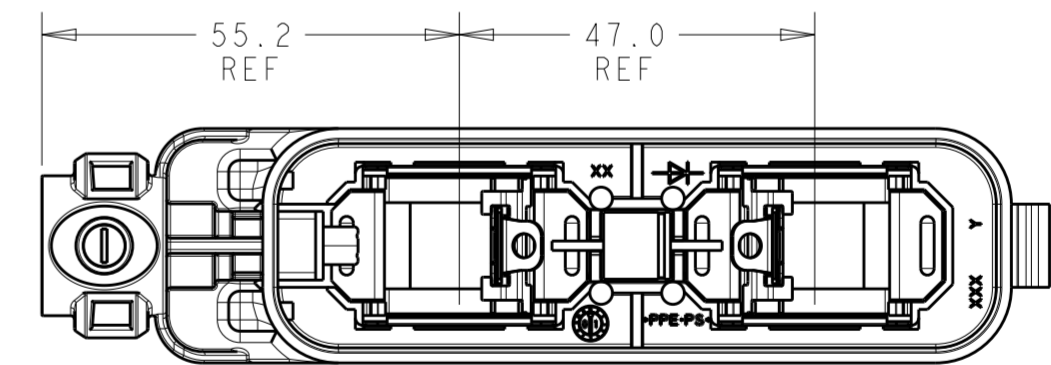

EAST-WEST VERSIONS  
 4-2306315-2  
 5-2306315-2  
 6-2306315-2  
 7-2306315-2  
 SAME AS N-S VERSIONS  
 EXCEPT AS SHOWN

THIS DRAWING IS A CONTROLLED DOCUMENT.		DWN RAVLS 12AUG2016	TE Connectivity	
DIMENSIONS: mm		CHK GINGRICH CHUCK 12AUG2016		
TOLERANCES UNLESS OTHERWISE SPECIFIED:		APVD GINGRICH CHUCK 12AUG2016	NAME PV EDGE ASSEMBLY, WITHOUT FLAP, S CLIP	
0 PLC ±0.50		PRODUCT SPEC 108-32122	SIZE A2	
1 PLC ±0.25		APPLICATION SPEC 114-32157	CAGE CODE -	
2 PLC ±0.13		WEIGHT -	DRAWING NO G-2306315	
3 PLC ±		CUSTOMER DRAWING	RESTRICTED TO -	
4 PLC ±		SCALE 5:1	SHEET 2 OF 4	
ANGLES ±			REV A	
FINISH -				

THIS DRAWING IS UNPUBLISHED. RELEASED FOR PUBLICATION  
 © COPYRIGHT copyright.d8te- ALL RIGHTS RESERVED.

REVISIONS				
P	LTR	DESCRIPTION	DATE	APVD
-		SEE SHEET 1	-	-

LID NOT SHOWN FOR REFERENCE ONLY

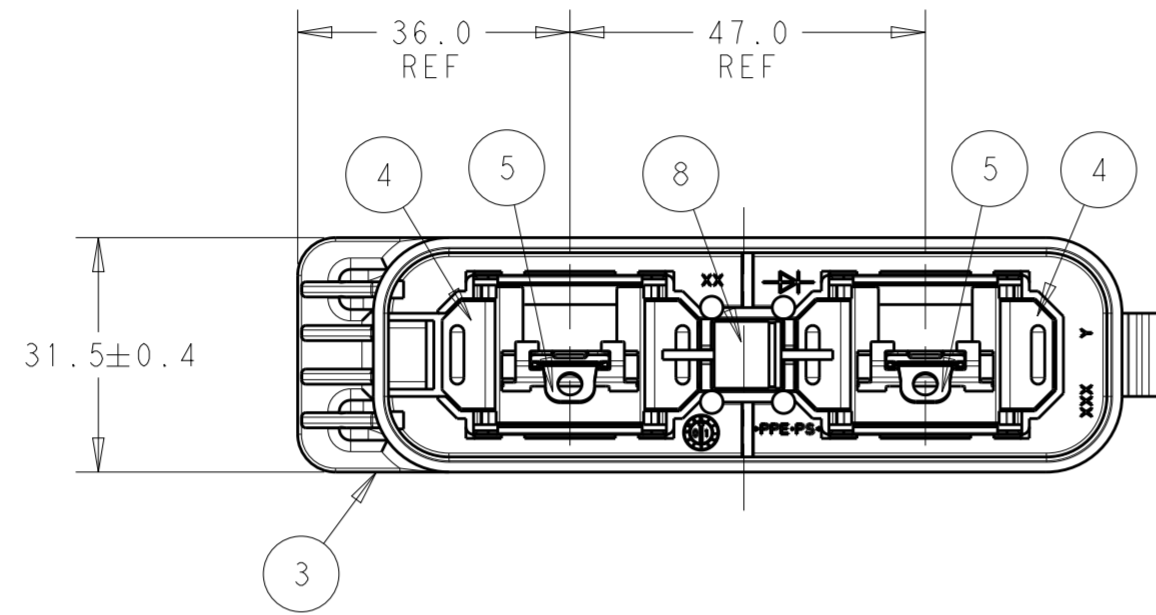

LID NOT SHOWN FOR REFERENCE ONLY

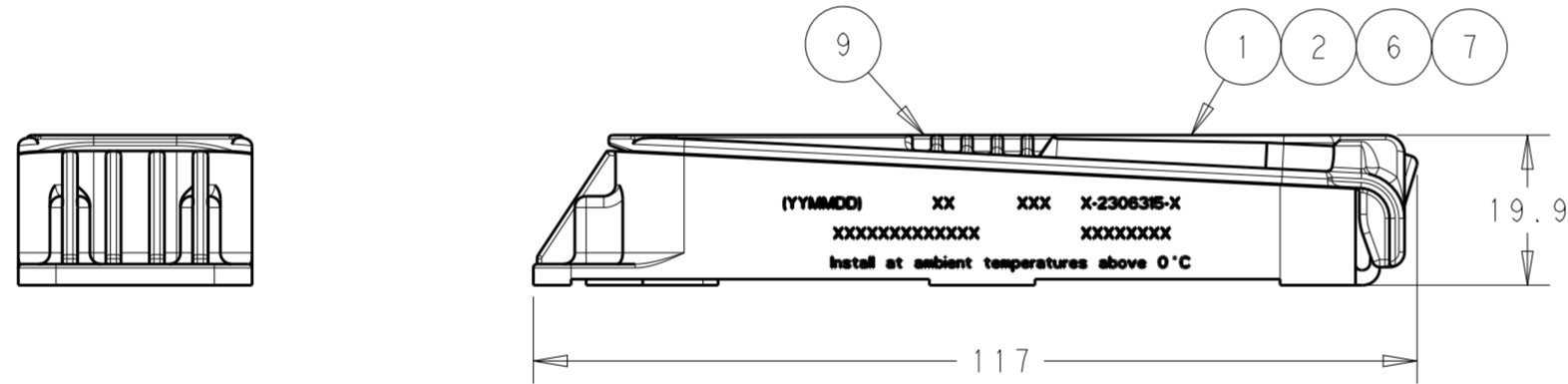
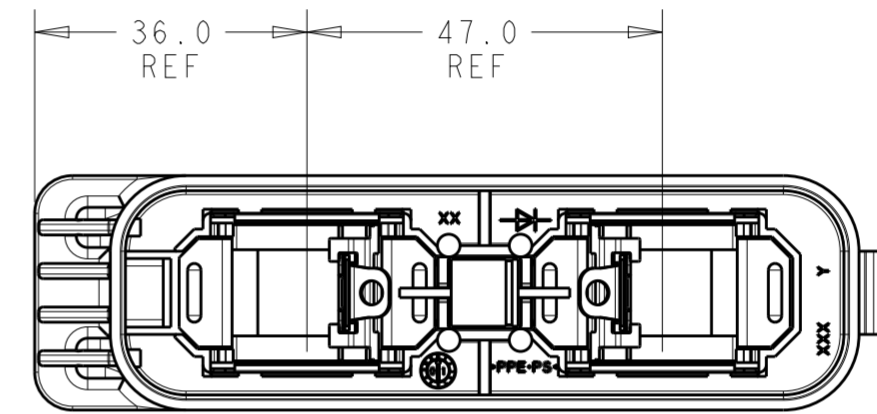

EAST-WEST VERSIONS  
 4-2306315-5  
 5-2306315-5  
 6-2306315-5  
 7-2306315-5  
 SAME AS N-S VERSIONS  
 EXCEPT AS SHOWN

NORTH-SOUTH VERSIONS  
 2306315-5  
 1-2306315-5  
 2-2306315-5  
 3-2306315-5  
 SHOWN

THIS DRAWING IS A CONTROLLED DOCUMENT.		DWN RAVLS 12AUG2016	 TE Connectivity	
DIMENSIONS: mm		CHK GINGRICH 12AUG2016		
TOLERANCES UNLESS OTHERWISE SPECIFIED:		APVD GINGRICH 12AUG2016	NAME PV EDGE ASSEMBLY, WITHOUT FLAP, S CLIP	
0 PLC ±0.50		PRODUCT SPEC 108-32122	RESTRICTED TO	
1 PLC ±0.25		APPLICATION SPEC 114-32157	SIZE A2	CAGE CODE -
2 PLC ±0.13		WEIGHT -	DRAWING NO C-2306315	
3 PLC ±		CUSTOMER DRAWING	SCALE 5:1	SHEET 3 OF 4
4 PLC ±			REV A	
ANGLES ±				
FINISH -				

THIS DRAWING IS UNPUBLISHED. RELEASED FOR PUBLICATION  
 © COPYRIGHT copyright.d8te- ALL RIGHTS RESERVED.

REVISIONS				
P	LTR	DESCRIPTION	DATE	APVD
-		SEE SHEET 1	-	-

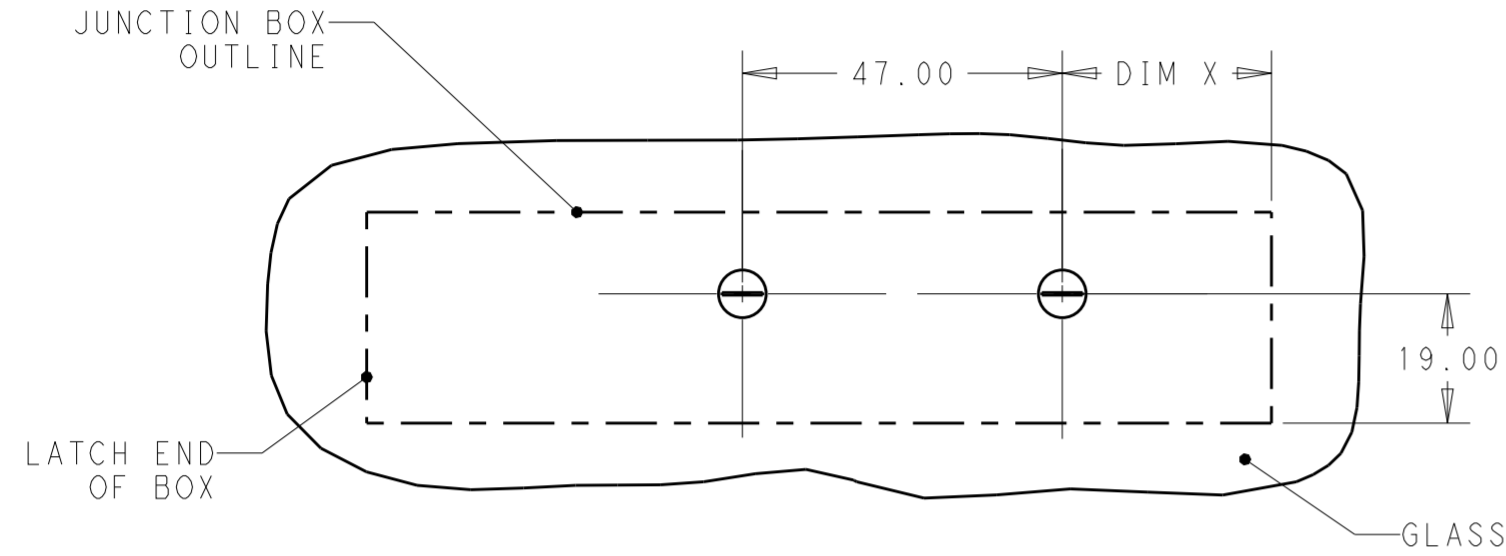

RECOMMENDED NON-EDGE MOUNT  
(NORTH-SOUTH PV PANEL FOIL ORIENTATION)

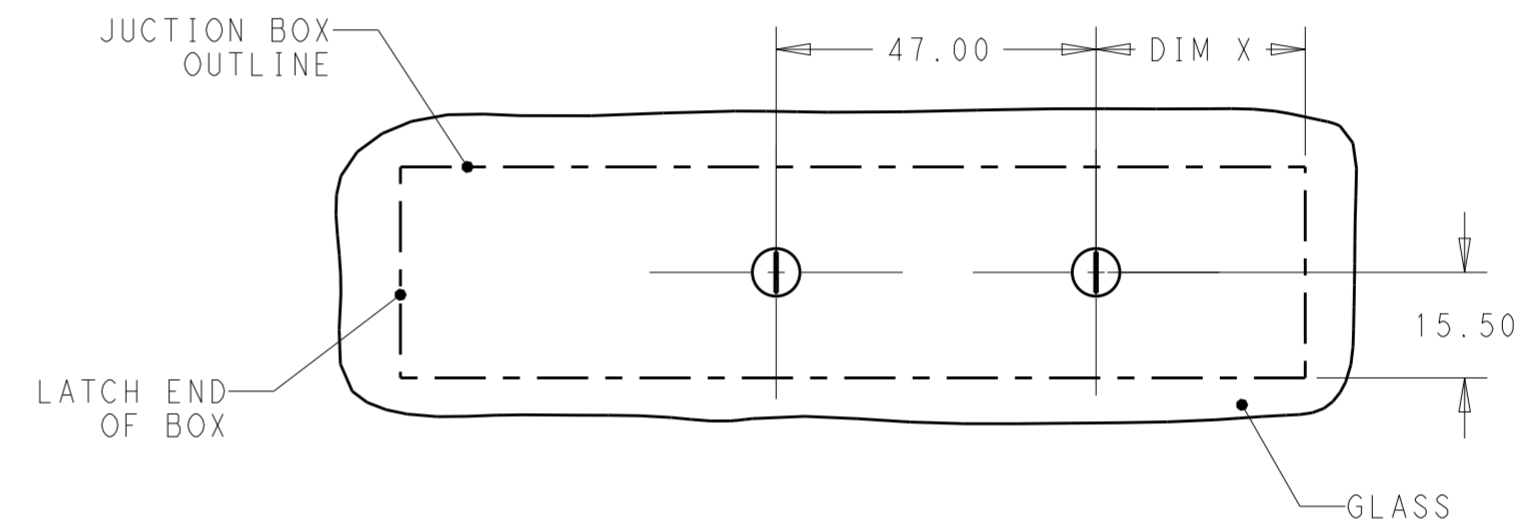
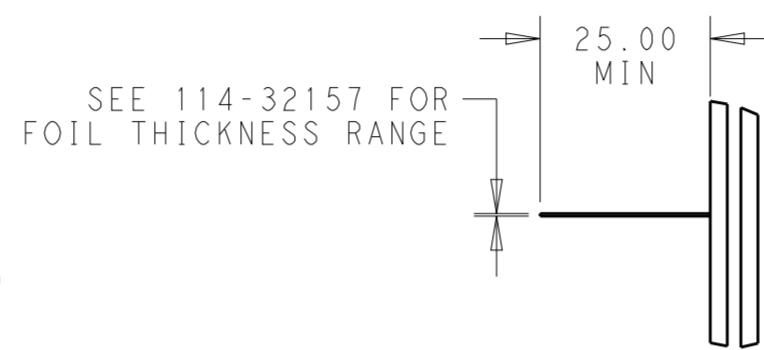

RECOMMENDED NON-EDGE MOUNT  
(EAST-WEST PV PANEL FOIL ORIENTATION)

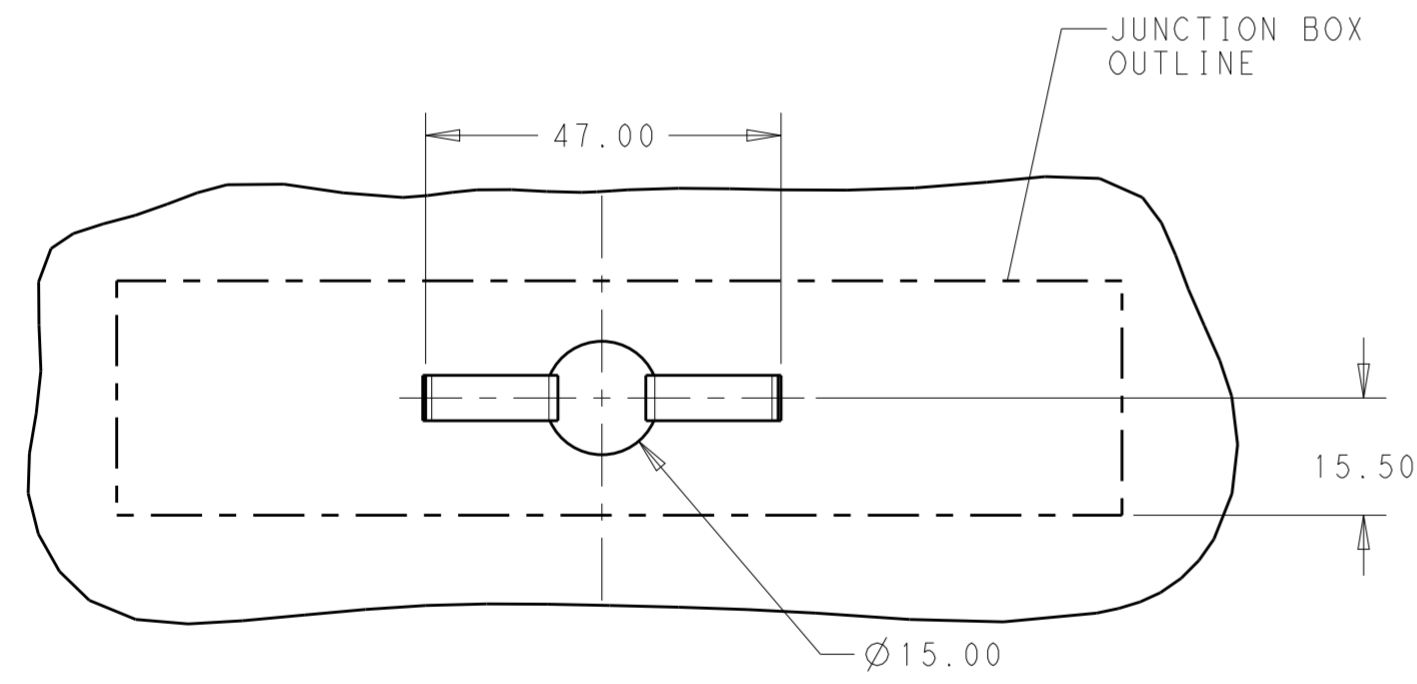
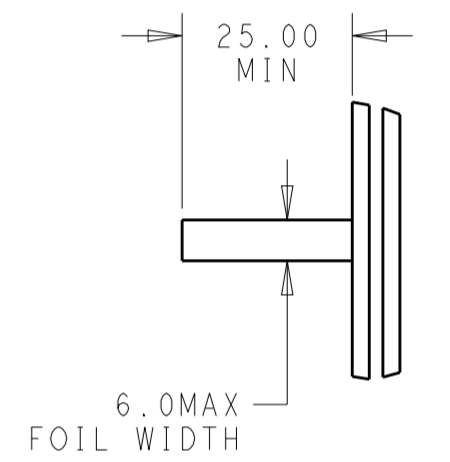

RECOMMENDED NON-EDGE MOUNT  
(SINGLE HOLE ORIENTATION)

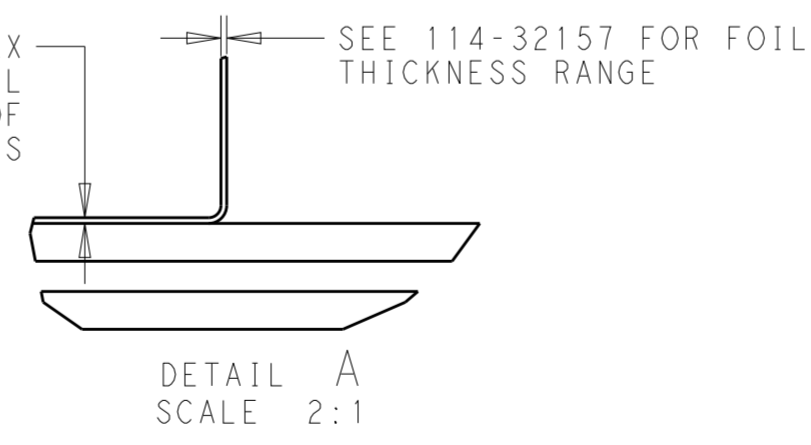
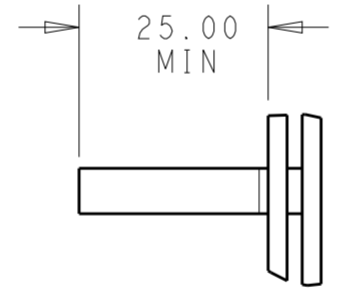
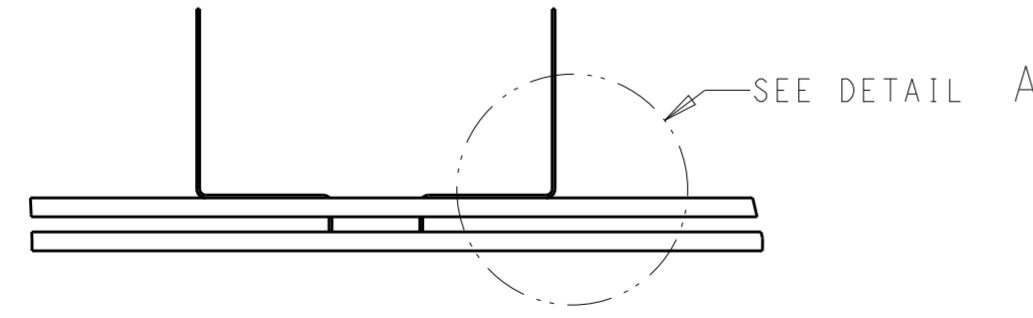

THIS DRAWING IS A CONTROLLED DOCUMENT.		DWN RAVLS 12AUG2016	TE Connectivity	
DIMENSIONS: mm		CHK GINGRICH CHUCK 12AUG2016		
TOLERANCES UNLESS OTHERWISE SPECIFIED:		APVD GINGRICH CHUCK 12AUG2016	NAME PV EDGE ASSEMBLY, WITHOUT FLAP, S CLIP	
0 PLC ±0.50		PRODUCT SPEC 108-32122	SIZE A2	
1 PLC ±0.25		APPLICATION SPEC 114-32157	CAGE CODE -	
2 PLC ±0.13		WEIGHT -	DRAWING NO C-2306315	
3 PLC ±		CUSTOMER DRAWING	RESTRICTED TO -	
4 PLC ±			SCALE 5:1	
ANGLES ±			SHEET 4 OF 4	
FINISH -			REV A	

## Данный компонент на территории Российской Федерации

### Вы можете приобрести в компании MosChip.

Для оперативного оформления запроса Вам необходимо перейти по данной ссылке:

<http://moschip.ru/get-element>

Вы можете разместить у нас заказ для любого Вашего проекта, будь то серийное производство или разработка единичного прибора.

В нашем ассортименте представлены ведущие мировые производители активных и пассивных электронных компонентов.

Нашей специализацией является поставка электронной компонентной базы двойного назначения, продукции таких производителей как XILINX, Intel (ex.ALTERA), Vicor, Microchip, Texas Instruments, Analog Devices, Mini-Circuits, Amphenol, Glenair.

Сотрудничество с глобальными дистрибьюторами электронных компонентов, предоставляет возможность заказывать и получать с международных складов практически любой перечень компонентов в оптимальные для Вас сроки.

На всех этапах разработки и производства наши партнеры могут получить квалифицированную поддержку опытных инженеров.

Система менеджмента качества компании отвечает требованиям в соответствии с ГОСТ Р ИСО 9001, ГОСТ РВ 0015-002 и ЭС РД 009

### Офис по работе с юридическими лицами:

105318, г.Москва, ул.Щербаковская д.3, офис 1107, 1118, ДЦ «Щербаковский»

Телефон: +7 495 668-12-70 (многоканальный)

Факс: +7 495 668-12-70 (доб.304)

E-mail: [info@moschip.ru](mailto:info@moschip.ru)

Skype отдела продаж:

moschip.ru

moschip.ru\_4

moschip.ru\_6

moschip.ru\_9