

SD71175

REV.	DATE	REVISION DESCRIPTION	BY	C.K.D.
1	12-24-76	SEE REV REF PRINT SHEET 2 (ECB1291)	RWD	RWB
2	2-8-71	SEE REV REF PRINT SHTS 1&2 (ECB1324)	PJR	RWB
3	2-22-71	SHEET 1, BLACK STRIP ADDED TO FIG. I - III (ECB1357)	PJB	RWB
4	4-26-71	SEE REV REF PRINT SH. 1 (ECB1399)	RWD	RWB
5	9-20-71	SEE REV REF PRINT SH. 1 (ECB1496)	P.G.P.	RWB
6	30MAY72	SEE REV. REF. PRINT (ECB1695)	POP	RWB
7	7-17-72	PLATING TABLE REMOVED (ECB1703)	RWD	RWB

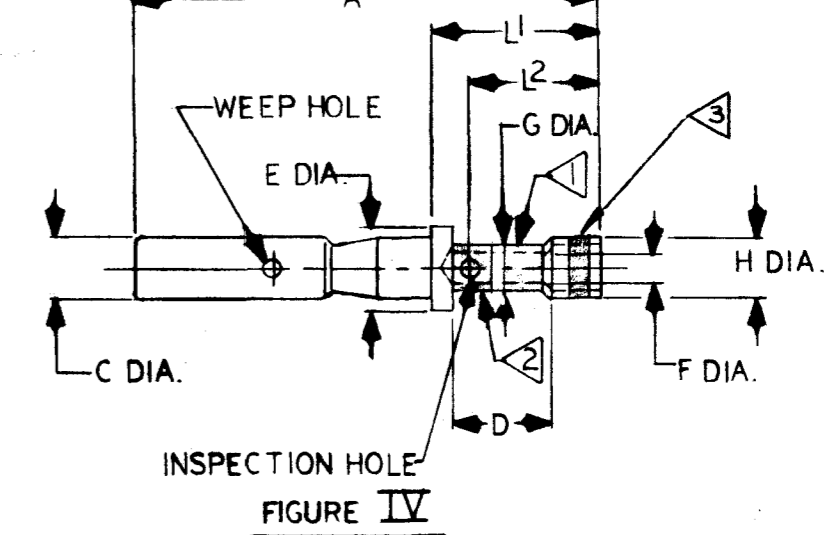
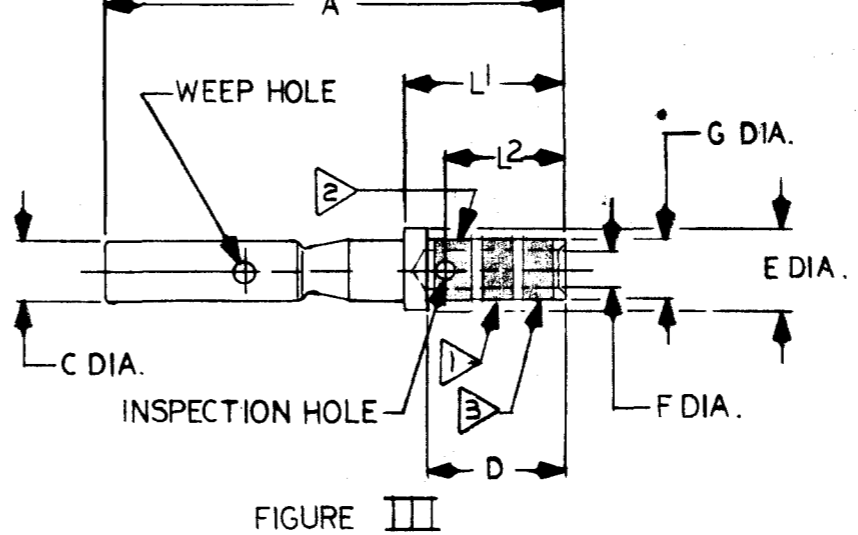
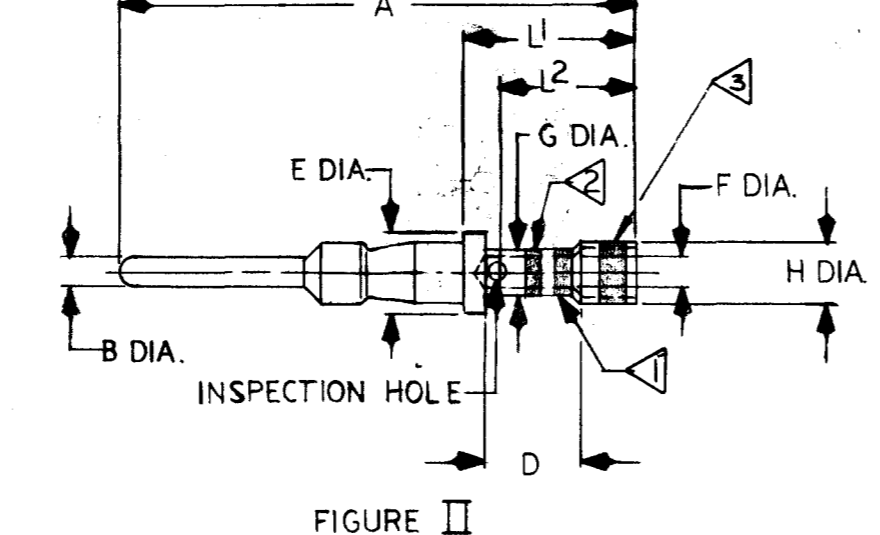
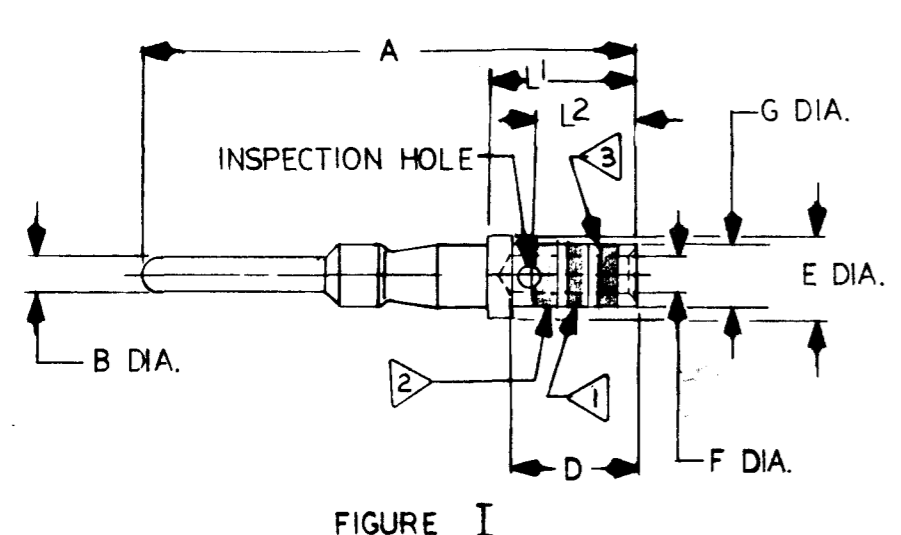
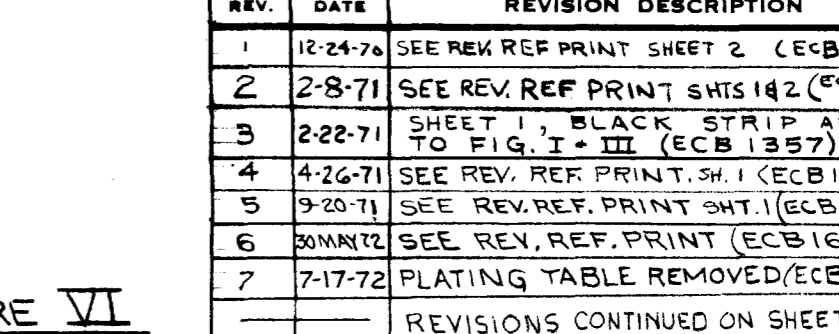
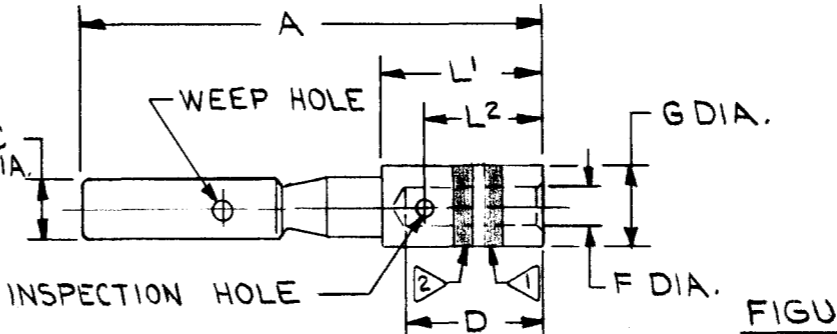
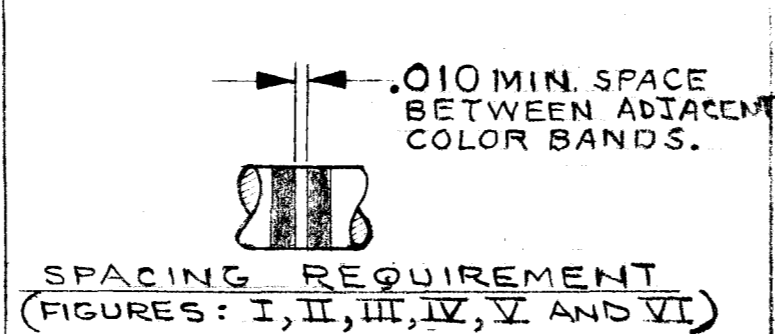
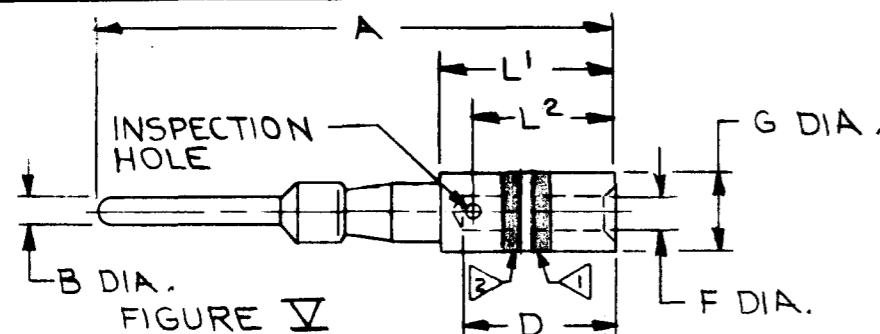

DOUGLAS CONTACT CATALOG NO.	PIN OR SOCKET	MATING END		WIRE BARREL				TOOLING					FIG.	A	B DIA.	C DIA.	D STRIP LENGTH	E DIA.	F DIA.	G DIA.	H DIA.	WEIGHT LBS./M.	BURNDY CATALOG NUMBER	L1	L2		
		SIZE	COLOR CODE	SIZE	COLOR CODE	CONDUCTOR		INSULATION		CRIMP TOOL	DIE SET	STOP BUSHING														INSERTION TOOL	EXTRACTION TOOL
						MIN.	MAX.	MIN. DIA.	MAX. DIA.																		
LRM27-5DES	P	12	YELLOW	12	YELLOW	(#14)	(#12)	.112	.146	S-8	SL-4	RTM12-5	RX12-7	I	.905	.094		9/32	202/198	102/098	153/147		3.4	LRM27-5DES	296	220	
LRC127-5DES	S													III	.844		161/158	9/32	202/198	102/098	153/147		3.5	LRC127-5DES	296	220	
LRM16M-5DES	P	16	BLUE	16	BLUE	(#20)	(#16)			S-7	SL-2	RTM16-2V2	RX16-7V1	III	.905	.0625		9/32	148/144	068/066	108/101		1.6	LRM16M-5DES	296	220	
LRC16M-5DES	S													III	.844		113/110	9/32	148/144	068/066	108/101		1.7	LRC16M-5DES	296	220	
LRM16M-6DES	P	16	BLUE	16	BLUE	(#20)	(#16)	.074	.110	S-7	SL-2	RTM16-2V2	RX16-8	I	1.093	.0625		9/32	148/144	068/066	108/101		2.1	LRM16M-6DES	296	220	
LRC16M-6DES	S													III	1.091		113/110	9/32	148/144	068/066	108/101		2.2	LRC16M-6DES	296	220	
LRM16W-2DES	P	20	RED	16	BLUE	(#20)	(#16)			S-7	SL-44	RTM16-2	RX20-24V3	V	.905	.040		9/32		068/066	105/101		.9	LRM16W-2DES	296	220	
LRC16W-2DES	S													VI	.844		078/076	9/32		068/066	105/101		1.0	LRC16W-2DES	296	220	
LRM20M-1DES	P	16	BLUE	20	RED	(#24)	(#20)			S-6A	SL-64	RTM20-5	RX16-8	II	.915	.0625		7/32	148/144	050/048	078/076	.105	1.5	LRM20M-1DES	306	246	
LRC20M-1DES	S													IV	.854		113/110	7/32	148/144	050/048	078/076	.105	1.6	LRC20M-1DES	306	246	
LRM20M-2DES	P	16	BLUE	20	RED	(#24)	(#20)			S-6A	SL-64	RTM20-5	RX16-8	II	1.103	.0625		7/32	148/144	050/048	078/076	.105	2.0	LRM20M-2DES	306	246	
LRC20M-2DES	S													IV	1.101		113/110	7/32	148/144	050/048	078/076	.105	2.1	LRC20M-2DES	306	246	
LRM20W-5DES	P	20	RED	20	RED	(#24)	(#20)		.090	M10S-1		RTM20-5 OR RTM20-14	RX20-24V3	II	.915	.040		7/32	103/100	050/048	078/076	.105	.8	LRM20W-5DES	306	246	
LRC20W-5DES	S								.039			RTM20-5 OR RTM20-14	RX20-24V3	IV	.854		078/076	7/32	103/106	050/048	078/076	.105	.9	LRC20W-5DES	306	246	
LRM22M-1DES	P	16	BLUE	22	GREEN	(#24)	(#22)			S-6A	SL-64	RTM16-2	RX16-7	II	.915	.0625		7/32	148/144	038/036	066/064	.105	1.7	LRM22M-1DES	306	246	
LRC22M-1DES	S											RTM16-2	RX16-8	IV	.854		113/110	7/32	148/144	038/036	066/064	.105	1.8	LRC22M-1DES	306	246	
LRM22M-2DES	P	16	BLUE	22	GREEN	(#24)	(#22)		.080	S-6A	SL-64	RTM16-2	RX16-8	II	1.103	.0625		7/32	148/144	038/036	066/064	.105	1.8	LRM22M-2DES	306	246	
LRC22M-2DES	S											RTM16-2	RX16-8	IV	1.101		113/110	7/32	148/144	038/036	066/064	.105	2.2	LRC22M-2DES	306	246	

PLATING TABLE	
SUFFIX	PLATING
DES	GOLD OVER COPPER

NOTES:

▲▲▲ DENOTES WIRE BARREL.
 ▲▲ DENOTES MATING END.
 BLACK DENOTES 5015 TYPE CONTACT AND IS ONLY APPLICABLE IF 3 APPEARS TO LEFT OF CATALOG NUMBER.

▲ TO ORDER REEL MOUNTED CONTACTS, PRECEDE CONTACT CATALOG NO. WITH "C" - EXAMPLE - CLRC16M-5DES INDICATES LRC16M-5DES CONTACTS MOUNTED IN REELED CARRY STRIP FOR BANDOMATIC ASSEMBLY. REF. ASTM B33-63 AIRCRAFT WIRE ONLY.

▲ FOR NEW CONTACTS REPLACING SUPERSED CONTACTS SEE DWG. SDW1119

IDENTIFICATION STRIPES IN ACCORDANCE WITH:
 MIL-C-23216
 MS 3190
 MS 3192C
 MS 3193B

MATERIAL: BRASS

FSCM NO. 09922

BANTAM PIN AND SOCKET CONTACTS

CAT. NO. LRM/LRC (TABLE)

SCALE

DRAWN: RJR2 10-29-70

CHECKED: 11-6-70

DES. APPROV. 11-13-70 C.B.

PROD. APPROV. 11-13-70

BURNDY NORWALK, CONN. 06852

DRAWING NO. SD71175

REV. 13

SHEET 1 OF 2

SD7117S

REV.	DATE	REVISION DESCRIPTION	BY	C'K'D.
12	11-21-83	SHT. 1, NOTE 3, ADDED AND IS ONLY APPLICABLE IF B APPEARS TO LEFT OF CAT. NO. (DC11095)	DA	C.B.
13	3/24/79	REMOVED BR FROM DRAWING # MATERIAL: BRASS PER ECN #328	DAF	SAF

REV.	DATE	REVISION DESCRIPTION	BY	C'K'D.
REVISIONS CONTINUED FROM SHEET 1				
8	3-23-74	SHEET 2, NOTE 'A' WAS NOTE '4' NOTE 'B' ADDED (ECB1968 \$ADD.)	D.L.	P.J.B.
9	4-29-81	SHTS 1 & 2, SEE REV. REF. (ECC4269) PRINT.	L.H.	SFP
10	9-15-81	SHTS. 1 & 2 SEE REV. REF. (QC10,666) PRINTS	L.H.	SFP
11	9/9/83	ADDED NOTE 6, SUPERSEDED CAT. NO'S. LRM12Z23DES, LRC12Z23DES, LRM16M23DES, LRC16M23DES, LRM20W23DES, LRC20W23DES PER ECW1395	S.E.	CEB

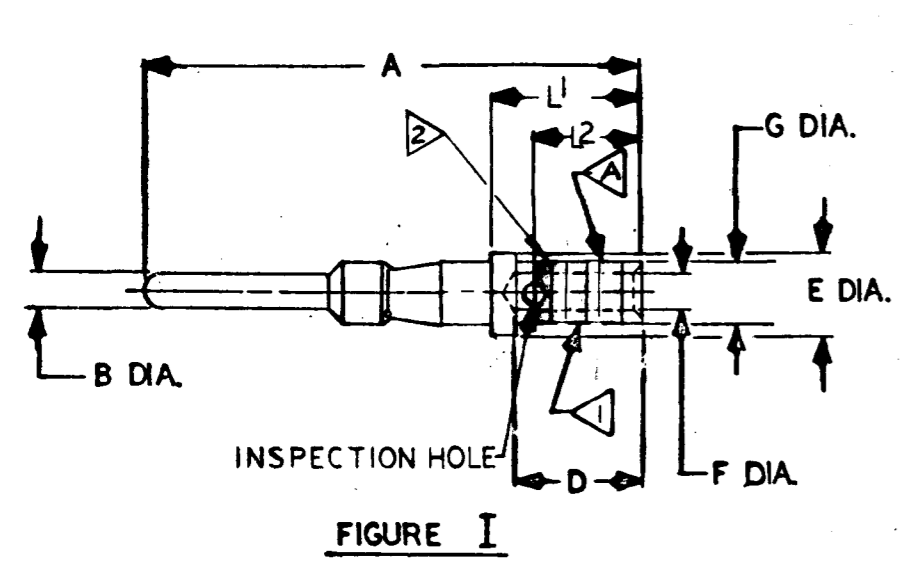

FIGURE I

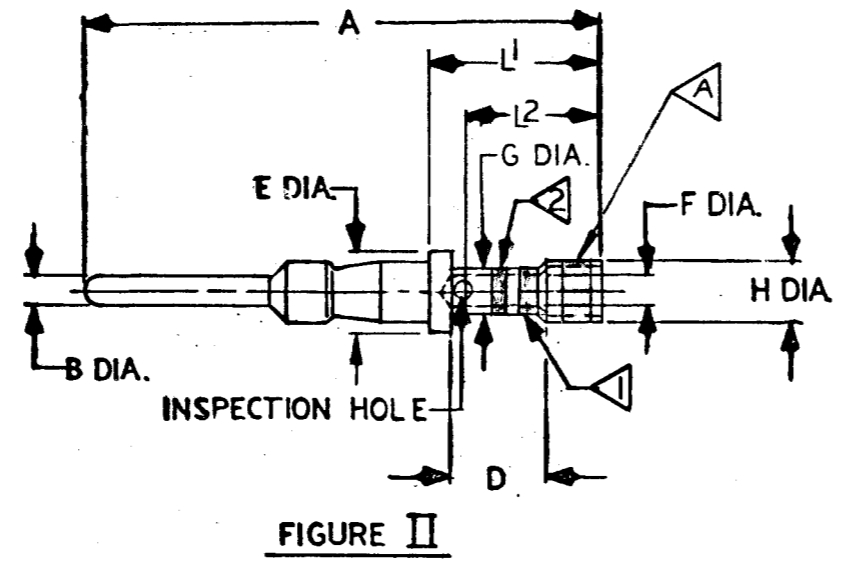

FIGURE II

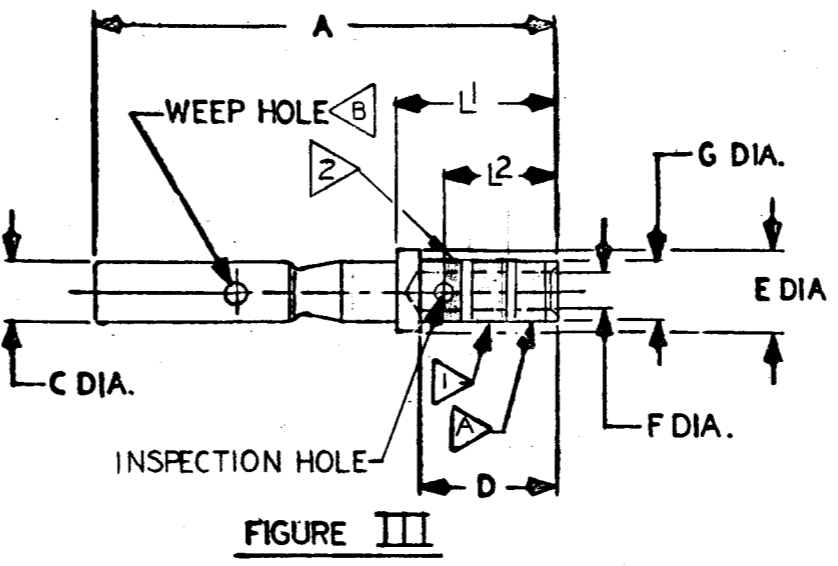

FIGURE III

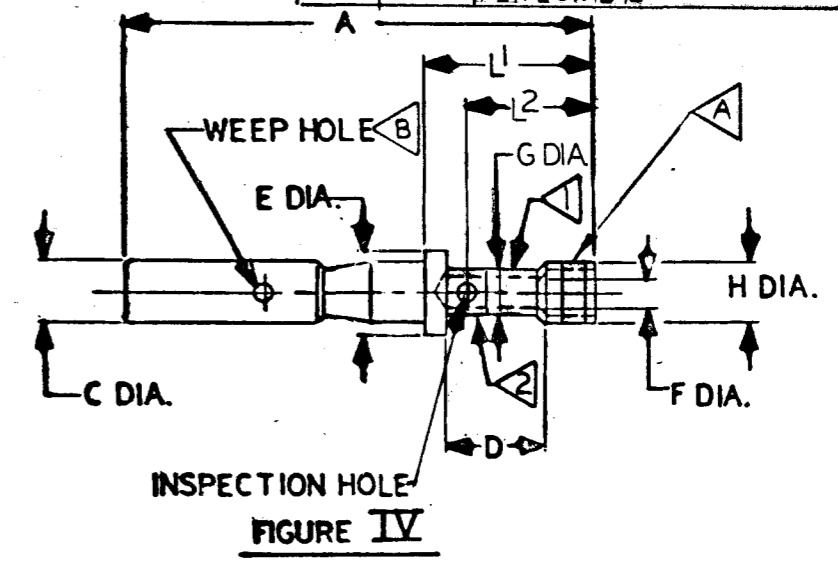

FIGURE IV

CONTACT CATALOG NO.	PIN OR SOCKET	MATING END		WIRE BARREL			TOOLING					FIG.	A ±.010	B DIA. ±.001	C DIA.	D STRIP LENGTH	E DIA.	F DIA. ±.001	G DIA.	H DIA. ±.001	MATERIAL	WEIGHT LBS/M	FINISH	L1 ±.002	L2 ±.005			
		SIZE	COLOR CODE	SIZE	COLOR CODE	MIN.	MAX.	PER	CRIMP TOOL	DIE SET	STOP BUSHING															INSERTION TOOL	EXTRACTION TOOL	
		ACCOMMODATES																										
LRM16M-9	P	16	BLUE	16	BLUE	.038	.057	REGULAR GRADE THERMOCOUPLE WIRE PER MIL-W-5846 TYPE I, CLASS D,E					I	.905	.0625		9/32		.067						.296	.220		
LRC16M-9	S	16	BLUE	16	BLUE	#20	#16					III	.844		.113/.110		9/32		.067							.296	.220	
LRM16M-10	P	16	BLUE	16	BLUE	.038	.057	THERMOCOUPLE WIRE PER MIL-W-5845 TYPE I, CLASS D,E					I	.905	.0625		9/32		.067							.296	.220	
LRC16M-10	S	16	BLUE	16	BLUE	#20	#16					III	.844		.113/.110		9/32		.067							.296	.220	
LRM16M-11	P	16	BLUE	16	BLUE	.038	.057	THERMOCOUPLE WIRE PER MIL-W-5845 TYPE I, CLASS D,E		S7	SL2	RTM16-2	RX16-7	I	.905	.0625		9/32		.067							.296	.220
LRC16M-11	S	16	BLUE	16	BLUE	#20	#16					III	.844		.113/.110		9/32		.067							.296	.220	
LRM16M-12	P	16	BLUE	16	BLUE	.038	.057	THERMOCOUPLE WIRE PER MIL-W-5845 TYPE I, CLASS D,E					I	.905	.0625		9/32		.067							.296	.220	
LRC16M-12	S	16	BLUE	16	BLUE	#20	#16					III	.844		.113/.110		9/32		.067							.296	.220	
LRM20W-9	P	20	RED	20	RED	.024	.038	REGULAR GRADE THERMOCOUPLE WIRE PER MIL-W-5846 TYPE I, CLASS D,E					II	.915	.040		7/32		.049							.306	.246	
LRC20W-9	S	20	RED	20	RED	#24	#20					IV	.854		.078/.076		7/32		.049							.306	.246	
LRM20W-10	P	20	RED	20	RED	.024	.038	THERMOCOUPLE WIRE PER MIL-W-5845 TYPE I, CLASS D,E		S6A	SL-3A	RTM20-5	RX20-24V3	II	.915	.040		7/32		.049							.306	.246
LRC20W-10	S	20	RED	20	RED	#24	#20					IV	.854		.078/.076		7/32		.049							.306	.246	
LRM20W-11	P	20	RED	20	RED	.024	.038	THERMOCOUPLE WIRE PER MIL-W-5845 TYPE I, CLASS D,E					II	.915	.040		7/32		.049							.306	.246	
LRC20W-11	S	20	RED	20	RED	#24	#20					IV	.854		.078/.076		7/32		.049							.306	.246	
LRM20W-12	P	20	RED	20	RED	.024	.038	THERMOCOUPLE WIRE PER MIL-W-5845 TYPE I, CLASS D,E					II	.915	.040		7/32		.049							.306	.246	
LRC20W-12	S	20	RED	20	RED	#24	#20					IV	.854		.078/.076		7/32		.049							.306	.246	

NOTES:
 ▲ GREEN DENOTES ALUMEL
 ▲ WHITE DENOTES CHROMEL
 ▲ YELLOW DENOTES CONSTANTAN
 ▲ BLACK DENOTES IRON
 THERMOCOUPLE CONTACTS ONLY

▲ WEEP HOLE ON LRC16M-11 AND LRC20W-11 ONLY.

▲ CONSULT FACTORY FOR AVAILABILITY.

FSCM NO. 09922

THERMOCOUPLE CONTACTS
 BANTAM PIN AND SOCKET CONTACTS

CAT. NO. LRM/LRC (TABLE) SCALE

DRAWN RJR2 10-29-70 CHECKED RWB 11-6-70
 DES. APPROV. 11-13-70 C.B.
 PROD. APPROV. 11-13-70

BURNDY
 NORWALK, CONN. 06852

DRAWING NO. SD7117S13
 SHEET 2 OF 2

DOB-1069

Данный компонент на территории Российской Федерации

Вы можете приобрести в компании MosChip.

Для оперативного оформления запроса Вам необходимо перейти по данной ссылке:

<http://moschip.ru/get-element>

Вы можете разместить у нас заказ для любого Вашего проекта, будь то серийное производство или разработка единичного прибора.

В нашем ассортименте представлены ведущие мировые производители активных и пассивных электронных компонентов.

Нашей специализацией является поставка электронной компонентной базы двойного назначения, продукции таких производителей как XILINX, Intel (ex.ALTERA), Vicor, Microchip, Texas Instruments, Analog Devices, Mini-Circuits, Amphenol, Glenair.

Сотрудничество с глобальными дистрибьюторами электронных компонентов, предоставляет возможность заказывать и получать с международных складов практически любой перечень компонентов в оптимальные для Вас сроки.

На всех этапах разработки и производства наши партнеры могут получить квалифицированную поддержку опытных инженеров.

Система менеджмента качества компании отвечает требованиям в соответствии с ГОСТ Р ИСО 9001, ГОСТ РВ 0015-002 и ЭС РД 009

Офис по работе с юридическими лицами:

105318, г.Москва, ул.Щербаковская д.3, офис 1107, 1118, ДЦ «Щербаковский»

Телефон: +7 495 668-12-70 (многоканальный)

Факс: +7 495 668-12-70 (доб.304)

E-mail: info@moschip.ru

Skype отдела продаж:

moschip.ru

moschip.ru_4

moschip.ru_6

moschip.ru_9