

The LTC-7PN series was design specifically to be printed circuit board (PCB) compatible. With a low profile, prismatic shape, this battery is unique in the industry and a perfect match for space saving requirements. Available in 3 PCB and 1 surface mounting configurations, these cells provide high quality, high energy density, non-position sensitive solutions to your high density electronics power needs.

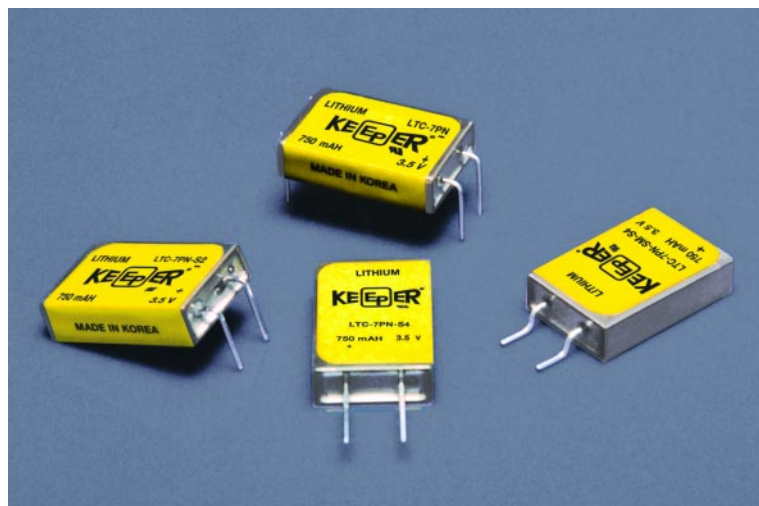

LTC-7PN PRODUCT FEATURES

- Compliant with lead-free RoHS and WEEE EC directives.
- Low profile, prismatic design.
- Stainless steel construction provides corrosion resistance, hermetic seal and structural integrity.
- Years of low rate continuous use.
- Stand-by use with 80% capacity retention after 15 years at room temperature.
- Highly efficient utilization of valuable board space.
- Wave solderable (limit solder bath exposure to a maximum of 5 seconds).
- High energy density compared to other chemistries.
- No charging circuits required.
- Higher cell voltage allows for fewer cells and high reliability.
- Flat discharge characteristics provide optimum voltage regulation.
- Non-pressurized system allow for high temperature usage.
- Ship unrestricted. IATA No. UN3090.
- Underwriters Laboratories recognized component.

TYPICAL LTC-7PN DISCHARGE CHARACTERISTICS AT VARIED TEMPERATURES

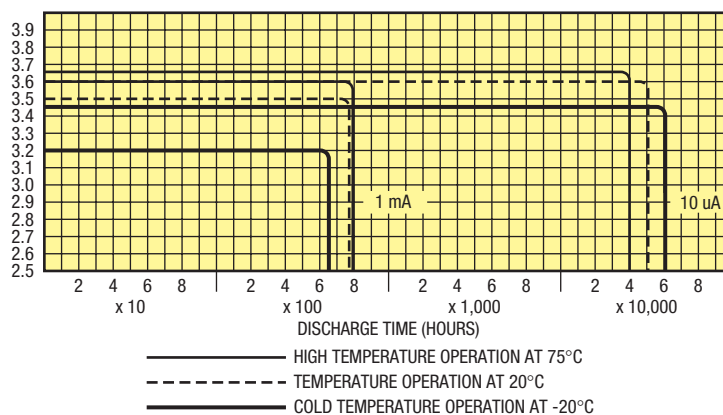

DO YOU HAVE QUESTIONS

CONCERNING:

- What size battery you need?
- What is passivation and its effects?
- What is the maximum rate of this cell?
- Any other technical question?

If so, call our Engineers at
1-800-201-0215 or 1-417-625-1116
 for detailed technical information.

Part Number	Voltage	Capacity (mAh)	Length (in.)	Width (in.)	Thickness (in.)	Weight (g)
LTC-7PN	3.5	750	1.00	0.65	0.26	6.8
LTC-7PN-S2	3.5	750	1.00	0.65	0.26	6.8
LTC-7PN-S4	3.5	750	0.65	0.26	1.00	6.8
LTC-7PN-SM-S4	3.5	750	1.00	0.70	0.26	6.8

SPECIFICATIONS LTC-7PN

Nominal Open Circuit Voltage, 25°C 3.67 volts
 Nominal Working Voltage, 25°C 3.5 volts
 Nominal Capacity (350 hr. rate), 25°C 750 mAh
 Volume1625 cu. in.
 Weight 6.8 GMS
 Operating Temperature
-40°C to +95°C
 Case Material:
 304 Stainless Steel,
 Hermetically Sealed
 (case negative polarity)
 Terminal and Support Pins are
 .030" dia. (solder tinned)

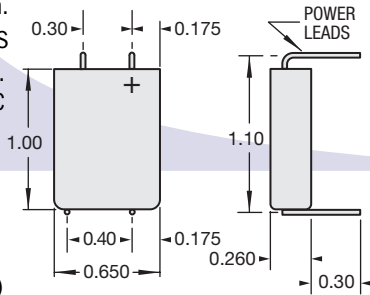

SPECIFICATIONS LTC-7PN-S4

Nominal Open Circuit Voltage, 25°C 3.67 volts
 Nominal Working Voltage, 25°C 3.5 volts
 Nominal Capacity (350 hr. rate), 25°C 750 mAh
 Volume1625 cu. in.
 Weight 6.8 GMS
 Operating Temperature
-40°C to +95°C
 Case Material:
 304 Stainless Steel,
 Hermetically Sealed
 (case negative polarity)
 Terminal and Support Pins are
 .030" dia. (solder tinned)

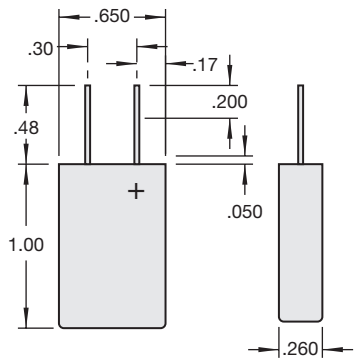

SPECIFICATIONS LTC-7PN-S2

Nominal Open Circuit Voltage, 25°C 3.67 volts
 Nominal Working Voltage, 25°C 3.5 volts
 Nominal Capacity (350 hr. rate), 25°C 750 mAh
 Volume1625 cu. in.
 Weight 6.8 GMS
 Operating Temperature
-40°C to +95°C
 Case Material: 304 Stainless Steel, Hermetically Sealed
 (case positive polarity)
 Terminal and Support Pins are .030" dia. (solder tinned)

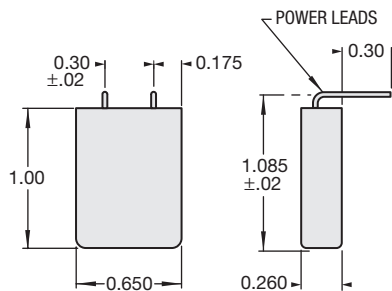

The specifications on this sheet may be changed by EaglePicher without notice.
 EaglePicher™ is a trademark of and Keeper® is a registered trademark of EaglePicher Corporation.

WE CAN DESIGN TO FIT ANY APPLICATION.

Our team of engineers can design any pin configuration required to fit your specialized application. If you don't see a battery configuration you need here, call us and we will begin working on a EPT part number just for you.

DISTRIBUTED LOCALLY BY:

Mouser Electronics

Authorized Distributor

Click to View Pricing, Inventory, Delivery & Lifecycle Information:

[Eagle-Picher:](#)

[LTC-7PNS4](#) [LTC-7PNS6](#) [LTC-7PN-S42](#) [LTC-7PN](#) [LTC7PN-SM-S4](#) [LTC7PN-S2](#)

Данный компонент на территории Российской Федерации

Вы можете приобрести в компании MosChip.

Для оперативного оформления запроса Вам необходимо перейти по данной ссылке:

<http://moschip.ru/get-element>

Вы можете разместить у нас заказ для любого Вашего проекта, будь то серийное производство или разработка единичного прибора.

В нашем ассортименте представлены ведущие мировые производители активных и пассивных электронных компонентов.

Нашей специализацией является поставка электронной компонентной базы двойного назначения, продукции таких производителей как XILINX, Intel (ex.ALTERA), Vicor, Microchip, Texas Instruments, Analog Devices, Mini-Circuits, Amphenol, Glenair.

Сотрудничество с глобальными дистрибьюторами электронных компонентов, предоставляет возможность заказывать и получать с международных складов практически любой перечень компонентов в оптимальные для Вас сроки.

На всех этапах разработки и производства наши партнеры могут получить квалифицированную поддержку опытных инженеров.

Система менеджмента качества компании отвечает требованиям в соответствии с ГОСТ Р ИСО 9001, ГОСТ РВ 0015-002 и ЭС РД 009

Офис по работе с юридическими лицами:

105318, г.Москва, ул.Щербаковская д.3, офис 1107, 1118, ДЦ «Щербаковский»

Телефон: +7 495 668-12-70 (многоканальный)

Факс: +7 495 668-12-70 (доб.304)

E-mail: info@moschip.ru

Skype отдела продаж:

moschip.ru

moschip.ru_4

moschip.ru_6

moschip.ru_9