

**DESCRIPTION**

These low capacitance diode arrays are multiple, discrete, isolated junctions fabricated by a planar process and mounted in a 14-PIN ceramic DIP package for use as steering diodes protecting up to eight I/O ports from ESD, EFT, or surge by directing them to the positive side of the power supply line and to ground (see Figure 1). An external TVS diode may be added between the positive supply line and ground to prevent over-voltage on the supply rail. They may also be used in fast switching core-driver applications. This includes computers and peripheral equipment such as magnetic cores, thin-film memories, plated-wire memories, etc., as well as decoding or encoding applications. These arrays offer many advantages of integrated circuits such as high-density packaging and improved reliability. This is a result of fewer pick and place operations, smaller footprint, smaller weight, and elimination of various discrete packages that may not be as user friendly in PC board mounting.

**IMPORTANT:** For the most current data, consult MICROSEMI's website: <http://www.microsemi.com>

**APPEARANCE**

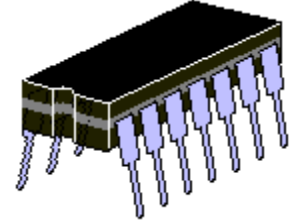

**14-PIN Ceramic DIP**

**FEATURES**

- Hermetic Ceramic Package
- Isolated Diodes To Eliminate Cross-Talk Voltages
- High Breakdown Voltage  $V_{BR} > 60$  V at 10  $\mu$ A
- Low Leakage  $I_R < 100$ nA at 40 V
- Low Capacitance  $C < 8.0$  pF
- Options for screening in accordance with MIL-PRF-19500/474 for JAN, JANTX, JANTXV, and JANS are available by adding MQ, MX, MV, or MSP prefixes respectively to part numbers. For example, designate MX1N6509 for a JANTX screen.

**MAXIMUM RATINGS**

- Reverse Breakdown Voltage of 60 Vdc (Note 1 & 2)
- Continuous Forward Current of 300 mA dc (Note 1 & 3)
- Peak Surge Current ( $t_p=1/120$  s) of 500 mA dc (Note 1)
- 400 mW Power Dissipation per Junction @ 25°C
- 600 mW Power Dissipation per Package @ 25°C (Note 4)
- Operating Junction Temperature range -65 to +150°C
- Storage Temperature range of -65 to +200°C

**NOTE 1:** Each Diode

**NOTE 2:** Pulsed:  $P_W = 100$  ms max; duty cycle  $\leq 20\%$

**NOTE 3:** Derate at 2.4 mA/°C above +25°C

**NOTE 4:** Derate at 4.8 mW/°C above +25°C

**APPLICATIONS / BENEFITS**

- High Frequency Data Lines
- RS-232 & RS-422 Interface Networks
- Ethernet: 10 Base T
- Computer I/O Ports
- LAN
- Switching Core Drivers
- IEC 61000-4 Compatible (see circuit in figure 1)  
61000-4-2 ESD: Air 15 kV, contact 8 kW  
61000-4-4 (EFT): 40 A - 5/50 ns  
61000-4-5 (surge): 12 A 8/20  $\mu$ s

**MECHANICAL AND PACKAGING**

- 14-PIN Ceramic DIP
- Weight 2.05 grams (approximate)
- Marking: Logo, part number, date code
- Pin #1 to the left of the indent on top of package
- Carrier tubes; 25 pcs (standard)

**ELECTRICAL CHARACTERISTICS (Per Diode) @ 25°C unless otherwise specified**

PART NUMBER	MAXIMUM FORWARD VOLTAGE $V_{F1}$ $I_F = 100$ mA (Note 1)	MAXIMUM FORWARD VOLTAGE $V_{F2}$ $I_F = 500$ mA (Note 1)	MAXIMUM REVERSE CURRENT $I_{R1}$ $V_R = 40$ V	MAXIMUM CAPACITANCE (PIN TO PIN) $C_t$ $V_R = 0$ V $F = 1$ MHz	MAXIMUM FORWARD RECOVERY TIME $t_{fr}$ $I_F = 500$ mA	MAXIMUM REVERSE RECOVERY TIME $t_{rr}$ $I_F = I_R = 200$ mA $i_{rr} = 20$ mA $R_L = 100$ ohms
	V	V	$\mu$ A	pF	ns	ns
<b>1N6509</b>	1	1.5	0.1	8.0	40	20

**NOTE 1:** Pulsed:  $P_W = 300$   $\mu$ s +/- 50  $\mu$ s, duty cycle  $\leq 2\%$ , 90  $\mu$ s after leading edge.

**SYMBOLS & DEFINITIONS**

Symbol	DEFINITION
$V_{BR}$	Minimum Breakdown Voltage: The minimum voltage the device will exhibit at a specified current.
$V_F$	Maximum Forward Voltage: The maximum forward voltage the device will exhibit at a specified current.
$I_R$	Maximum Leakage Current: The maximum leakage current that will flow at the specified voltage and temperature.
$C_t$	Capacitance: The capacitance of the TVS as defined @ 0 volts at a frequency of 1 MHz and stated in picofarads.

**SCHEMATIC**

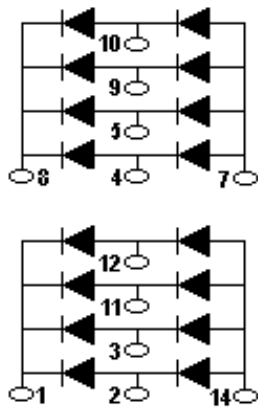

**PACKAGE DIMENSIONS**

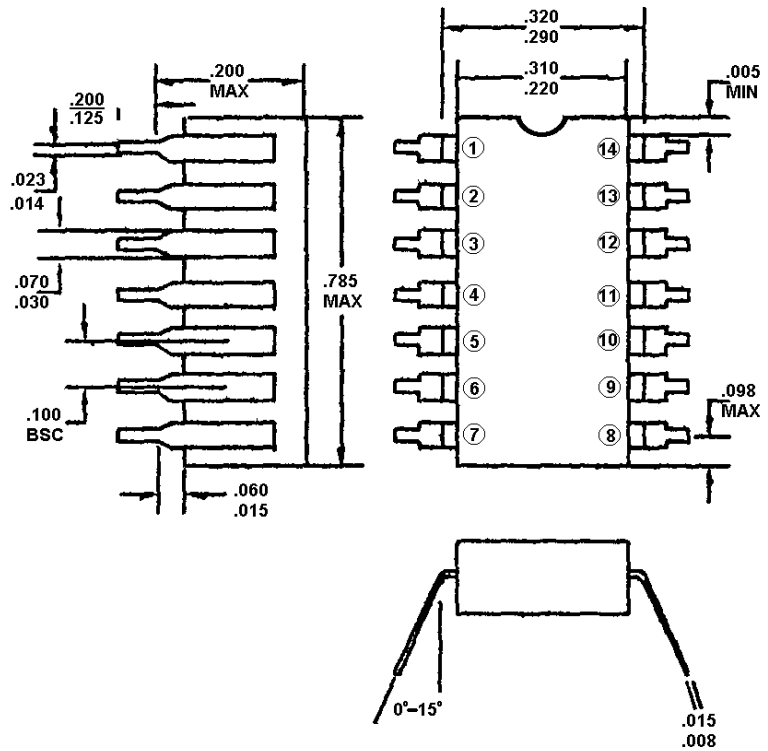

**CIRCUIT**

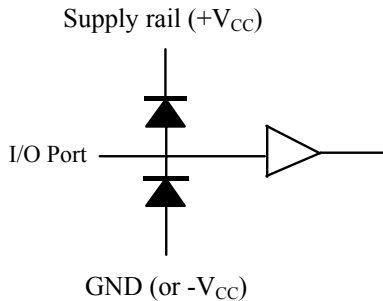

**Steering Diode Application**  
**FIGURE 1**

# Mouser Electronics

Authorized Distributor

Click to View Pricing, Inventory, Delivery & Lifecycle Information:

[Microchip:](#)

[1N6509](#)

## Данный компонент на территории Российской Федерации

### Вы можете приобрести в компании MosChip.

Для оперативного оформления запроса Вам необходимо перейти по данной ссылке:

<http://moschip.ru/get-element>

Вы можете разместить у нас заказ для любого Вашего проекта, будь то серийное производство или разработка единичного прибора.

В нашем ассортименте представлены ведущие мировые производители активных и пассивных электронных компонентов.

Нашей специализацией является поставка электронной компонентной базы двойного назначения, продукции таких производителей как XILINX, Intel (ex.ALTERA), Vicor, Microchip, Texas Instruments, Analog Devices, Mini-Circuits, Amphenol, Glenair.

Сотрудничество с глобальными дистрибьюторами электронных компонентов, предоставляет возможность заказывать и получать с международных складов практически любой перечень компонентов в оптимальные для Вас сроки.

На всех этапах разработки и производства наши партнеры могут получить квалифицированную поддержку опытных инженеров.

Система менеджмента качества компании отвечает требованиям в соответствии с ГОСТ Р ИСО 9001, ГОСТ РВ 0015-002 и ЭС РД 009

### Офис по работе с юридическими лицами:

105318, г.Москва, ул.Щербаковская д.3, офис 1107, 1118, ДЦ «Щербаковский»

Телефон: +7 495 668-12-70 (многоканальный)

Факс: +7 495 668-12-70 (доб.304)

E-mail: [info@moschip.ru](mailto:info@moschip.ru)

Skype отдела продаж:

moschip.ru

moschip.ru\_4

moschip.ru\_6

moschip.ru\_9