

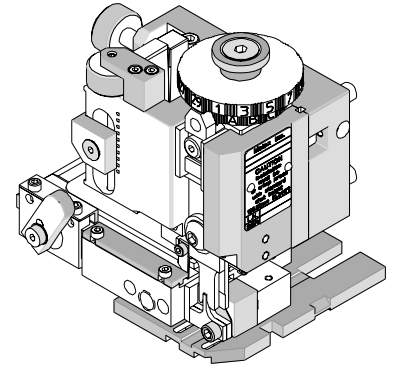

Mini-Mac Applicator Specification Sheet Order No. 63888-3000



FEATURES

- Directly adapts to most automatic wire processing machines
- Applicator designed to industry standard mounting and shut height 135.80mm (5.346")
- Quick set-up time; plus the crimp height, track and feed adjustments can be set without removing the applicator from the press
- Fine adjustment allows users to achieve target with little effort by adjusting in increments of .015mm (.0006") for conductor crimp height and .063mm (.0025") for insulation height
- Independent adjustment rings allow users to quickly adjust the conductor or insulation crimp height without affecting each other

SCOPE

Products: KK® Cat Ear and Anti Fish Hook Crimp Terminals, 22-30 AWG.

Terminal Series No	Terminal Order No.			Wire Size		Insulation Diameter		Strip Length	
				AWG	mm ²	mm	In.	mm	In.
4809	08-50-0030	08-55-0110	08-56-0158	22-30	0.35-0.05	1.12-1.57	.044-.062	2.54-3.18	.100-.125
	08-50-0031	08-55-0112	40-01-0829						
	08-50-0033	08-56-0120	97-00-0450						
	08-50-0135								
8088	08-52-0103	08-65-0105	97-00-0225	22-30	0.35-0.05	1.12-1.57	.044-.062	2.54-3.18	.100-.125
	08-52-0105	40-07-0812	97-00-0227						
	08-52-0107								

DEFINITION OF TERMS

This illustration is a generic terminal representation and not an exact image of any terminal listed in the scope.

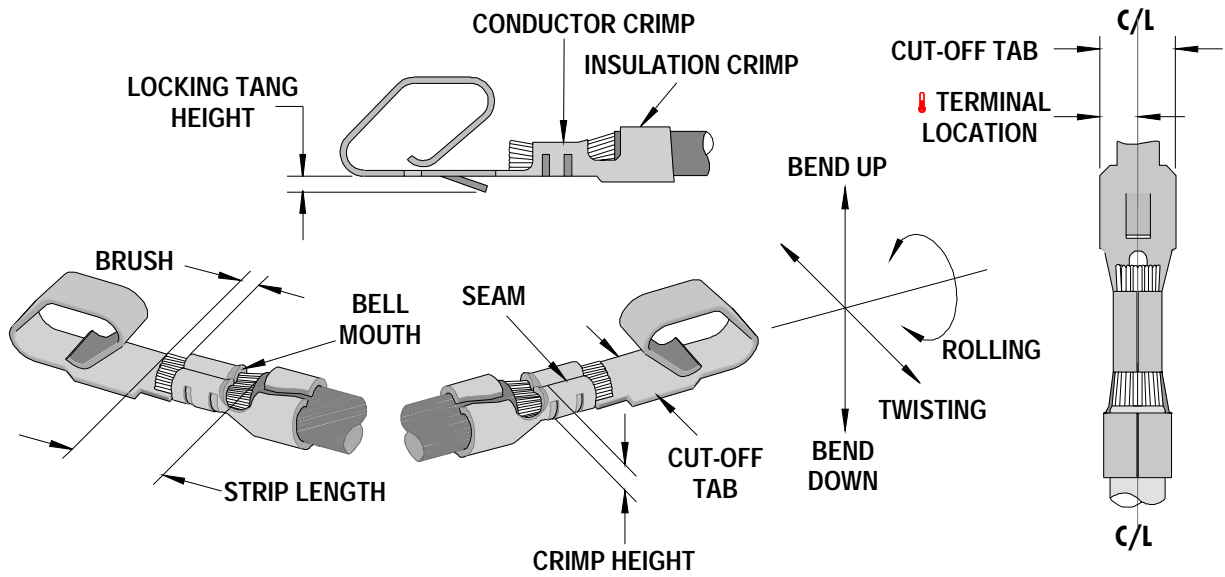

⚡ Terminal is to be centrally located between the two (2) cut-off tab edges by one half of the total cut-off tab tolerance.

CRIMP SPECIFICATIONS

Terminal Series No.	Bell mouth		⚡ Cut-off Tab		Conductor Brush	
	mm	In.	mm	In.	mm	In.
4809			1.85-1.98	.073-.078		
8088			1.85-1.98	.073-.078		

Terminal Series No.	Locking Tang Height		Bend up	Bend down	Twist	Roll	Punch Width (Ref)				Seam Seam shall not be open and no wire allowed out of the crimping area
	mm	In					Degree		Degree		
	mm	In	mm	In	mm	In	mm	In			
4809	0.64	.025	3	3	4	8	1.60	.063	1.68	.066	
8088	0.64	.025	3	3	4	8	1.60	.063	1.68	.066	

NOTE: Some of the specifications in these charts above are intentionally left blank due to the fact that the information does not currently exist.

After crimping, the conductor profile should measure the following.

Terminal Series No.	Wire Size		Conductor				Pull Force Minimum	
			Crimp Height		Crimp Width (Ref)			
	AWG	mm ²	mm	In.	mm	In.	N	Lb.
4809	22	0.35	0.79-0.84	.031-.033			44.88	10.0
	24	0.20	0.74-0.79	.029-.031			35.59	8.0
	26	0.12	0.68-0.74	.027-.029			26.69	6.0
	28	0.08	0.66-0.71	.026-.028			17.79	4.0
	30	0.05	0.63-0.66	.026-.027			13.34	3.0
8088	22	0.35	0.79-0.84	.031-.033			44.88	10.0
	24	0.20	0.74-0.79	.029-.031			35.59	8.0
	26	0.12	0.68-0.74	.027-.029			26.69	6.0
	28	0.08	0.66-0.71	.026-.028			17.79	4.0
	30	0.05	0.63-0.66	.026-.027			13.34	3.0

Pull Force should be measured with no influence from the insulation crimp.
 The above specifications are guidelines to an optimum crimp.

PARTS LIST

Mini-Mac Applicator 63888-3000				
Item	Order No	Engineering No.	Description	Quantity
Perishable Tooling				
	63888-3070	63888-3070	Tool Kit (All "Y" Items)	REF
1	11-18-4684	60756A101	Conductor Punch	1 Y
2	11-18-4685	60756A102	Conductor Anvil	1 Y
3	11-18-4686	60756A103	Insulation Punch	1 Y
4	11-18-4687	60756A104	Insulation Anvil	1 Y
5	11-18-4688	60756A105	Cut-Off Insert	1 Y
6	11-18-4689	60756A106	Cut-off Punch	1 Y
Other Components (REF 883050)				
7	11-18-4001	60703-3	Cover Plate	1
8	11-18-4003	60703-5	Front Cover	1
9	11-18-4348	60722A108	Tooling Washer	1
10	11-18-4469	60703-20	Retainer Block	1
11	11-18-4678	60756A111	Wire Stop	1
12	11-18-4754	60756A118	Terminal Stop and Scrap Shield	1
13	63803-5105	63803-5105	Conductor Bushing	1
14	63820-0012	63820-0012	Cover-Drag Frame	1
Frame				
15	63801-3201	63801-3201	Top	1
16	63801-3283	63801-3283	Base	1
17	63801-6550	63801-6550	Track	1
Hardware				
18	N/A	N/A	M3 by 6 Long SHCS	2**
19	N/A	N/A	M3 by 8 Long SHCS	2**
20	N/A	N/A	M4 by 8 Long SHCS	2**
21	N/A	N/A	M4 by 12 Long BHCS	2**
22	N/A	N/A	M5 by 10 Long SHCS	1**
23	N/A	N/A	M8 by 20 Long BHCS	1**
24	N/A	N/A	#6-32 by 1/2" Long BHCS	2**
25	N/A	N/A	#10-32 by 1-1/4" Long SHCS	1**
** Available from an industrial supply company such as MSC (1-800-645-7270).				

Assembly Drawing

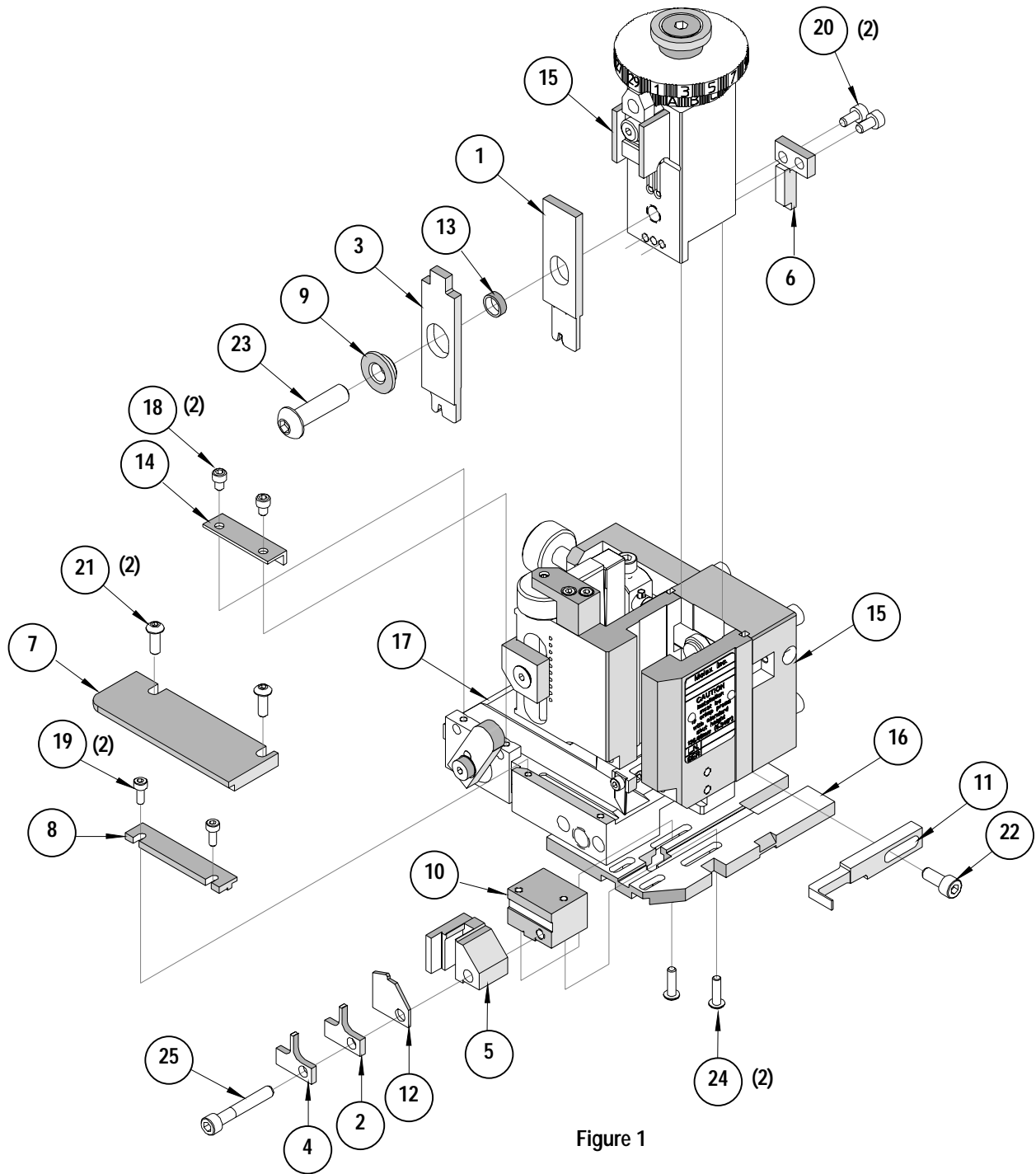

Figure 1

NOTES

1. Molex recommends an extra perishable tooling kit be maintained at your facility.
2. Verify tooling alignment by manually cycling the press and Applicator before crimping under power. Check that all screws are tight.
3. Slugs, Terminals, Dirt and Oil should be kept clear of work area.
4. Wear safety glasses at all times.
5. For recommended maintenance refer to the MiniMac Manual.

CAUTION: This applicator should only be used in a press with a shut height of 135.8 mm (5.346"). Tooling damage could result at a lower setting.

CAUTION: To prevent injury never operate this Applicator without the guards supplied with the press or wire-processing machine in place. Reference the press or wire processing manufacturer's instruction manual.

CAUTION: Molex crimp specifications are valid only when used with Molex terminals, applicators and tooling.

Americas Headquarters
Lisle, Illinois 60532 U.S.A.
1-800-78MOLEX
amerinfo@molex.com

Far East North Headquarters
Yamato, Kanagawa, Japan
81-462-65-2324
feninfo@molex.com

Far East South Headquarters
Jurong, Singapore
65-6-268-6868
fesinfo@molex.com

European Headquarters
Munich, Germany
49-89-413092-0
eurinfo@molex.com

Corporate Headquarters
2222 Wellington Ct.
Lisle, IL 60532 U.S.A.
630-969-4550
Fax: 630-969-1352

Visit our Web site at <http://www.molex.com>

Данный компонент на территории Российской Федерации

Вы можете приобрести в компании MosChip.

Для оперативного оформления запроса Вам необходимо перейти по данной ссылке:

<http://moschip.ru/get-element>

Вы можете разместить у нас заказ для любого Вашего проекта, будь то серийное производство или разработка единичного прибора.

В нашем ассортименте представлены ведущие мировые производители активных и пассивных электронных компонентов.

Нашей специализацией является поставка электронной компонентной базы двойного назначения, продукции таких производителей как XILINX, Intel (ex.ALTERA), Vicor, Microchip, Texas Instruments, Analog Devices, Mini-Circuits, Amphenol, Glenair.

Сотрудничество с глобальными дистрибьюторами электронных компонентов, предоставляет возможность заказывать и получать с международных складов практически любой перечень компонентов в оптимальные для Вас сроки.

На всех этапах разработки и производства наши партнеры могут получить квалифицированную поддержку опытных инженеров.

Система менеджмента качества компании отвечает требованиям в соответствии с ГОСТ Р ИСО 9001, ГОСТ РВ 0015-002 и ЭС РД 009

Офис по работе с юридическими лицами:

105318, г.Москва, ул.Щербаковская д.3, офис 1107, 1118, ДЦ «Щербаковский»

Телефон: +7 495 668-12-70 (многоканальный)

Факс: +7 495 668-12-70 (доб.304)

E-mail: info@moschip.ru

Skype отдела продаж:

moschip.ru

moschip.ru_4

moschip.ru_6

moschip.ru_9