

# QUINT-PS/ 3AC/24DC/20



Primary-switched power supply with SFB technology, 3 AC, output current 20 A

## INTERFACE

Data sheet  
303132\_en\_01

© PHOENIX CONTACT - 09/2009

### 1 Description

QUINT POWER power supply units – Maximum system availability with SFB technology  
Compact power supply units of the new QUINT POWER generation maximize the availability of your system. With the SFB technology (Selective Fuse Breaking Technology), six times the nominal current for 12 ms, even the standard power circuit-breakers can now also be triggered reliably and quickly. Faulty current paths are switched off selectively, the fault is located and important system parts continue to operate. Comprehensive diagnostics are provided through constant monitoring of output voltage and current. This preventive function monitoring visualizes critical operating modes and reports them to the control unit before an error can occur.

### Features

- Quick tripping of the standard power circuit-breakers using dynamic power reserve SFB technology
- Reliable starting of difficult loads with static POWER BOOST power reserve
- Preventive function monitoring
- Can be used worldwide
- High operating safety due to long mains buffering under full load and high MTBF (> 500,000 h)
- Perfect functioning even in the event of a permanent phase failure
- High surge voltage strength up to 6 kV (surge, asymmetric) using an integrated gas arrester



#### DANGER OF EXPLOSION!

Only remove equipment when it is disconnected and not in the potentially explosive area.



#### DANGER

Components with dangerously high voltage and high stored energy are located in the device!  
Never carry out work on live parts!  
Depending on the ambient temperature and the load, the housing can become very hot!



Make sure you always use the latest documentation.  
It can be downloaded at [www.phoenixcontact.net/download](http://www.phoenixcontact.net/download)

**2 Table of contents**

1 Description ..... 1  
    Features..... 1

2 Table of contents.....2

3 Ordering data .....3

4 Technical data .....3

5 Structure.....7

6 Block diagram .....8

7 Safety notes .....8

8 Installation .....9

9 Installation position.....9

10 Mounting on DIN rails ..... 10  
    Slim-style installation ..... 10  
    Low-profile installation ..... 10

11 Connection to various systems..... 11

12 Input ..... 11  
    Protection of the primary side..... 11  
    Required backup fuse (device and line protection) ..... 11

13 Output ..... 12  
    Protection of the secondary side..... 12

14 Signaling ..... 12  
    Floating contact..... 13  
    Active signal outputs ..... 13  
    Signal loop ..... 13

15 Function ..... 14  
    Output characteristic curve ..... 14  
    Thermal behavior ..... 14  
    Parallel operation ..... 15

### 3 Ordering data

Description	Type	Order No.	Pcs. / Pkt.
Primary-switched power supply with SFB technology, 3 AC, output current 20 A	QUINT-PS/ 3AC/24DC/20	2866792	1

Accessories	Type	Order No.	Pcs. / Pkt.
Assembly adapter for QUINT POWER 10A on S7-300 rail	QUINT-PS-ADAPTERS7/2	2938206	1
Universal wall adapter	UWA 182/52	2938235	1
Fan for QUINT-PS ... power supply. The fan eliminates the position-dependent derating of the power supply.	QUINT-PS/FAN/4	2320076	1

### 4 Technical data

Input data	
Input nominal voltage range	3x 400 V AC ... 500 V AC
AC input voltage range	3x 320 V AC ... 575 V AC 2x 360 V AC ... 575 V AC
DC input voltage range	450 V DC ... 800 V DC
AC frequency range	45 Hz ... 65 Hz
DC frequency range	0 Hz
Current consumption	Approx. 3x 1.6 A (400 V AC) Approx. 3x 1.3 A (500 V AC) Approx. 2x 3.2 A (400 V AC) Approx. 2x 2.8 A (500 V AC)
Inrush current limitation	< 20 A (typical)
$I^2t$	< 3.2 A <sup>2</sup> s
Power failure bypass	> 20 ms (400 V AC) > 30 ms (500 V AC)
Typical response time	< 0.5 s
Protective circuitry	Transient surge protection Varistor, gas-filled surge arrester
Recommended backup fuse for mains protection	6 A (characteristic B) 10 A (characteristic B) 16 A (characteristic B)
Discharge current to PE	< 3.5 mA

Output data	
Nominal output voltage	24 V DC $\pm$ 1%
Setting range of the output voltage	18 V DC ... 29.5 V DC (> 24 V constant capacity)
Output current	20 A (-25°C ... 70°C, U <sub>OUT</sub> = 24 V DC) 26 A (with POWER BOOST, -25°C ... 40°C permanently, U <sub>OUT</sub> = 24 V DC) 120 A (with SFB technology, 12 ms)
Magnetic fuse tripping	max 16 A (characteristic B) max 6 A (Characteristic C)
Derating	From +60°C 2.5% per Kelvin
Power loss nominal load max.	40 W
Maximum power dissipation idling	11 W
Efficiency	> 93 % (at 400 V AC and nominal values)
Ascent time	< 0.5 s (U <sub>OUT</sub> (10% ... 90%))
Residual ripple	< 40 mV <sub>PP</sub> (with nominal values)
Peak switching voltages	< 40 mV <sub>PP</sub> (at nominal values, 20 MHz)
Connection in parallel	Yes, for redundancy and increased capacity

**Output data (Continued)**

Connection in series	Yes
Surge protection against internal surge voltages	Yes, limited to approx. 35 V DC
Resistance to reverse feed	max. 35 V DC

**DC OK active**

Output description	$U_{OUT} > 0.9 \times U_N$ : High signal
Voltage	+ 18 V ... 24 V
Current	$\leq 20$ mA (short circuit resistant)
Status display	$U_{OUT} > 0.9 \times U_N$ : "DC OK" LED green / $U_{OUT} < 0.9 \times U_N$ : Flashing "DC OK" LED

**DC OK floating**

Output description	Relay contact, $U_{OUT} > 0.9 \times U_N$ : Contact closed
Voltage	$\leq 30$ V AC/DC
Current	$\leq 1$ A ( $\leq 0.5$ A / at 60 V AC/DC)
Status display	$U_{OUT} > 0.9 \times U_N$ : "DC OK" LED green / $U_{OUT} < 0.9 \times U_N$ : Flashing "DC OK" LED

**POWER BOOST, active**

Output description	$I_{OUT} < I_N$ : High signal
Voltage	+ 18 V ... 24 V
Current	$\leq 20$ mA (short circuit resistant)
Status display	$I_{OUT} > I_N$ : LED "BOOST" yellow /

**General data**

Insulation voltage input/output	4 kV AC (type test) 2 kV AC (routine test)
Insulation voltage input / PE	3.5 kV AC (type test) 2 kV AC (routine test)
Insulation voltage output / PE	500 V DC (routine test)
Degree of protection	IP20
Class of protection	I, with PE connection
MTBF	> 500 000 h in acc. with IEC 61709 (SN 29500)
Type of housing	Steel sheet, zinc-plated
Housing material	Steel sheet, zinc-plated
Dimensions W / H / D (state of delivery)	69 mm / 130 mm / 125 mm
Dimensions W / H / D (90° turned)	125 mm / 130 mm / 72 mm
Weight	1.5 kg

**Ambient conditions**

Ambient temperature (operation)	-25 °C ... 70 °C (> 60 °C derating)
Ambient temperature (storage/transport)	-40 °C ... 85 °C
Max. permissible relative humidity (operation)	95 % (at 25 °C, no condensation)
Vibration (operation)	< 15 Hz, amplitude $\pm 2.5$ mm in acc. with IEC 60068-2-6 15 Hz ... 150 Hz, 2.3g, 90 min.
Shock	30g in all directions in acc. with IEC 60068-2-27
Pollution degree in acc. with EN 50178	2
Climatic class	3K3 (in acc. with EN 60721)

**Standards**

Electrical Equipment for Machinery	EN 60204 / Surge voltage category III
Safety transformers for power supply units	IEC 61558-2-17
Electrical safety (of information technology equipment)	IEC 60950/VDE 0805 (SELV)
Electronic equipment for use in electrical power installations	EN 50178/VDE 0160 (PELV)

### Standards (Continued)

SELV	IEC 60950 (SELV) and EN 60204 (PELV)
Safe isolation	DIN VDE 0100-410 DIN VDE 0106-1010
Protection against electric shock	DIN 57100-410
Protection against electric shock, basic requirements for safe isolation in electrical equipment	DIN VDE 0106-101
Limitation of mains harmonic currents	EN 61000-3-2
Device safety	GS (tested safety)
Network variants (undervoltage)	Semi F47-0706
Certificate	CB Scheme

### Approvals

UL approvals	UL Listed UL 508 UL/C-UL Recognized UL 60950 (3-wire + PE, star net) UL/C-UL Listed UL 1604 Class I, Division 2, Groups A, B, C, D
--------------	--

### Conformance with EMC guideline 2004/108/EC and for low-voltage guideline 2006/95/EC

#### Noise immunity according to EN 61000-6-2

Electrostatic discharge	EN 61000-4-2	
	Housing	Level 4
	Contact discharge	8 kV (Contact discharge)
	Discharge in air	15 kV (Air discharge)
	Comments	Criterion B
Electromagnetic HF field	EN 61000-4-3	
	Housing	Level 4
	Frequency range	80 MHz ... 1000 MHz (20 V/m) 1 GHz ... 3 GHz (10 V/m)
	Field intensity	
	Comments	Criterion A
Fast transients (burst)	EN 61000-4-4	
	Input	4 kV (level 4 - asymmetrical: conductor to ground)
	Output	2 kV (Level 3 - asymmetrical)
	Signal	1 kV (level 2 - asymmetrical: conductor to ground)
	Comments	Criterion B
Surge current loads (surge)	EN 61000-4-5	
	Input	6 kV (asymmetrical: Conductor to ground) 3 kV (symmetrical: Conductor to conductor)
	Output	2 kV (level 3 - asymmetrical: conductor to ground)
	Signal	1 kV (level 1 - symmetrical: conductor to conductor)
	Comments	Criterion B
Conducted interference	EN 61000-4-6	
	Input/Output/Signal	Level 3 - asymmetrical
	Frequency range	0.15 MHz ... 80 MHz
	Voltage	10 V
	Comments	Criterion A
Voltage dips	EN 61000-4-11	
	Input	(Mains buffering > 20 ms (Semi F47))
	Comments	Criterion B

**Emitted interference in acc. with EN 61000-6-3**

Radio interference voltage in acc. with EN 55011

EN 55011 (EN 55022) Class B, area of application: Industry and residential

Emitted radio interference in acc. with EN 55011

EN 55011 (EN 55022) Class B, area of application: Industry and residential

## 5 Structure

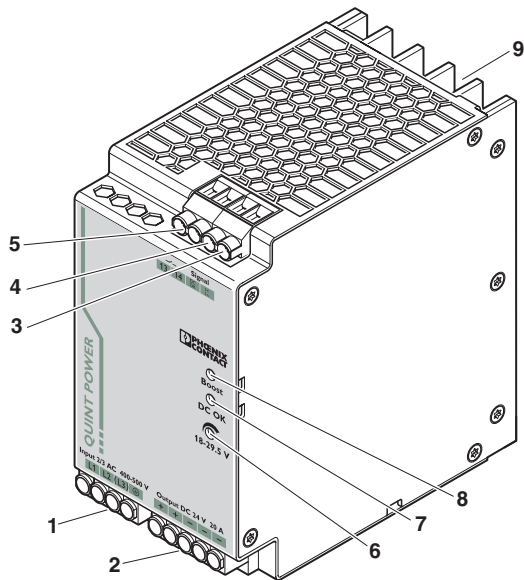

- 1 AC input
- 2 DC output
- 3 POWER BOOST switching output, active
- 4 DC OK switching output active
- 5 DC OK output, floating
- 6 Potentiometer 18 V DC ... 29.5 V DC
- 7 "DC OK" LED
- 8 "BOOST" LED
- 9 Universal DIN rail adapter UTA 107

	[mm <sup>2</sup> ]		AWG	[Nm] Torque
	solid	stranded		
Input	0.2 - 6	0.2 - 4	18 - 10	0.5 - 0.6
Output	0.2 - 6	0.2 - 4	12 - 10	0.5 - 0.6
Signal	0.2 - 6	0.2 - 4	18 - 10	0.5 - 0.6

### Input data

Input nominal voltage range	3x 400 V AC ... 500 V AC
AC input voltage range	3x 320 V AC ... 575 V AC 2x 360 V AC ... 575 V AC
DC input voltage range	450 V DC ... 800 V DC
AC frequency range	45 Hz ... 65 Hz
DC frequency range	0 Hz
Recommended backup fuse for mains protection	6 A (characteristic B) 10 A (characteristic B) 16 A (characteristic B)
Type of connection	Screw connection
Stripping length	7 mm

### Output data

Nominal output voltage	24 V DC ±1%
Setting range of the output voltage	18 V DC ... 29.5 V DC (> 24 V constant capacity)
Output current	20 A (-25°C ... 70°C, U <sub>OUT</sub> = 24 V DC) 26 A (with POWER BOOST, -25°C ... 40°C permanently, U <sub>OUT</sub> = 24 V DC) 120 A (with SFB technology, 12 ms)
Type of connection	Screw connection
Stripping length	7 mm

## 6 Block diagram

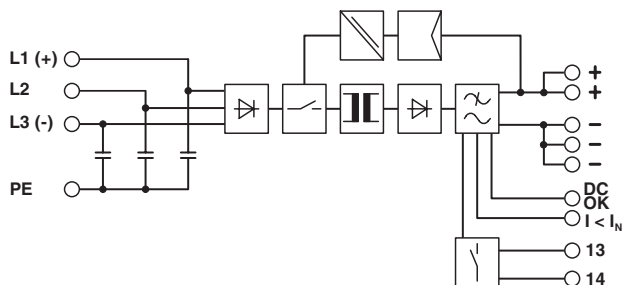

## 7 Safety notes



### DANGER OF EXPLOSION!

Only remove equipment when it is disconnected and not in the potentially explosive area.

### DANGER

Components with dangerously high voltage and high stored energy are located in the device!

Never carry out work on live parts!

Depending on the ambient temperature and the load, the housing can become very hot!



### WARNING

Before startup please ensure:

The mains connection has been carried out by a competent person and protection against electric shock is guaranteed!

The device can be disconnected outside the power supply unit in accordance with the regulations as in EN 60950 (e.g. through primary side line protection)!

The ground conductor is connected!

All feed lines are sufficiently protected and dimensioned!

All output lines are dimensioned according to the maximum output current of the device or separately protected!

Sufficient convection is guaranteed!



### ATTENTION

The power supply units are built-in devices. The device may only be installed and put into operation by qualified personnel. The corresponding national regulations must be observed.



## 8 Installation

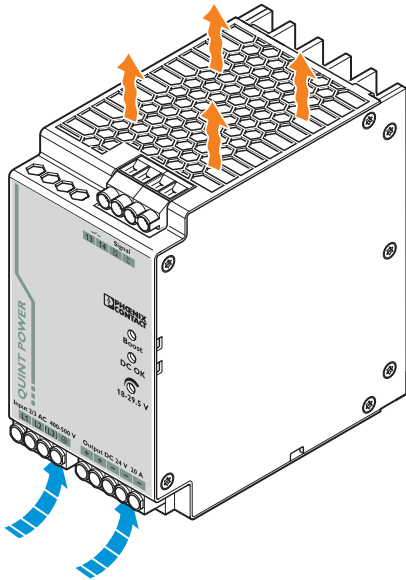

### ATTENTION

In order to ensure sufficient convection, we recommend a minimum vertical distance of 50 mm to the other modules. A lateral distance of 5 mm, and in the case of active components, that of 15 mm is necessary for proper functioning of the module.

Depending on the ambient temperature and the load of the module, the housing can become very hot!



The power supply unit can be snapped onto all DIN rails as per EN 60715; it can also be mounted on walls. The device must be mounted vertically (connecting terminals above or below).

## 9 Installation position

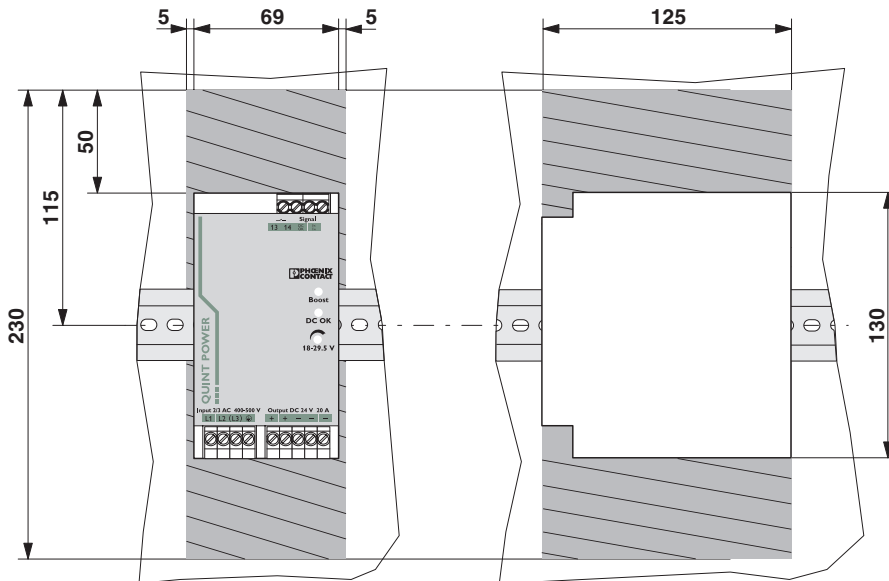

Slim-style installation: Installation depth 125 mm (+ DIN rail)  
(state at delivery)

Low-profile installation: Installation depth 72 mm (+ DIN rail)

## 10 Mounting on DIN rails

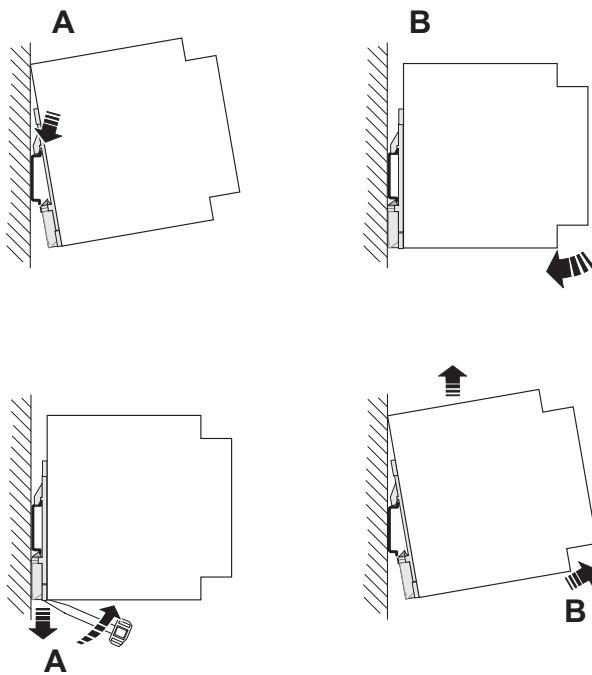

### Slim-style installation

Assembly:

Position the module with the DIN rail guide on the upper edge of the DIN rail, and snap it in with a downward motion.

Removing:

Pull the snap lever open with the aid of a screwdriver and slide the module out at the lower edge of the DIN rail.

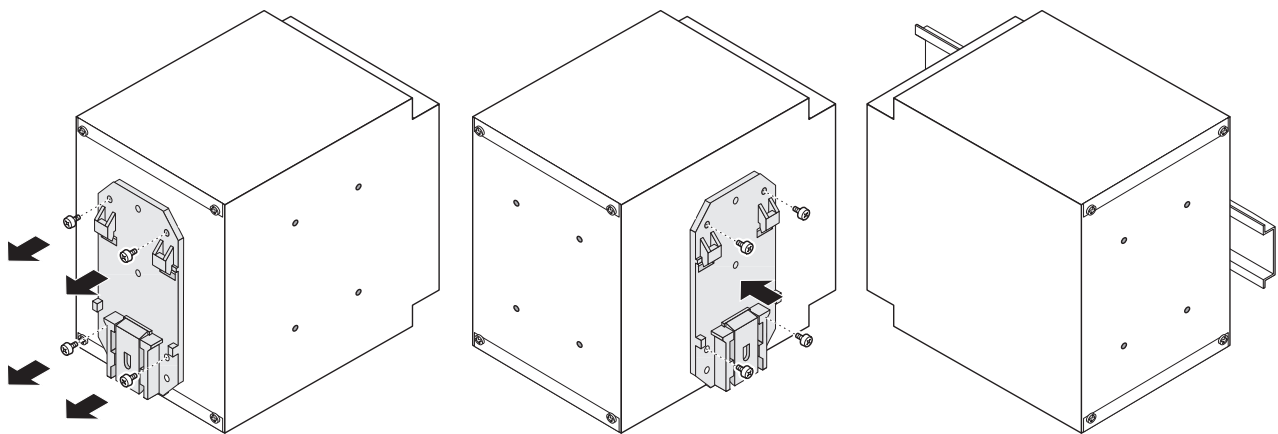

### Low-profile installation

Low-profile installation can be achieved by mounting the device at right-angles to the DIN rail. Mount the DIN rail adapter (UTA 107/30) as described in the figure. No additional mounting material is required. Fixing screws: Torx T10 (torque 0.8 Nm ... 0.9 Nm).

## 11 Connection to various systems

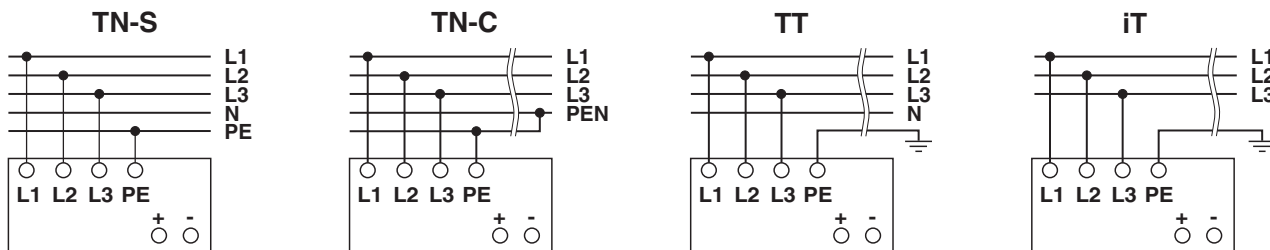

The connection for 3x 400 V AC ... 500 V AC is achieved using the L1, L2, L3 and PE screw connections. The device can be connected to 3-phase systems with nominal voltages 3x 400 V AC ... 500 V AC are connected. In the event of a phase failure, unrestricted operation is possible with nominal capacity. An operation in DC networks is also possible without any limitations.



### ATTENTION

In DC applications, a suitable fuse must be wired upstream!  
 Connect not more than one power supply unit to a fuse or a power switch.  
 Suggestion: In AC connections, connect a maximum of one power supply unit to a fuse or a power switch.  
 In order to comply with UL approval, use copper cables with an operating temperature of > 75°C (ambient temperature < 55°C) and > 90°C (ambient temperature < 75°C).

## 12 Input

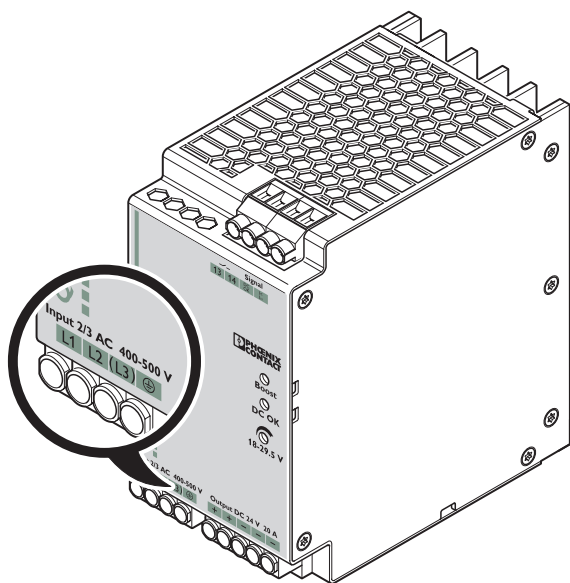

### ATTENTION

If an external fuse is triggered, there is most probably a malfunction in the device. In this case, the device must be inspected in the factory!

### Protection of the primary side

The device must be installed in acc. with the regulations as in EN 60950. It must be possible to disconnect the device using a suitable isolating facility outside the power supply. Primary circuit mains protection, for example, is suitable for this purpose.

### Required backup fuse (device and line protection)

External thermo-magnetic fuses are necessary for device protection: 2/3 x 6 A, 10 A or 16 A power circuit breaker, characteristic B (or identical function).

Connect a suitable fuse upstream for DC applications!

### 13 Output

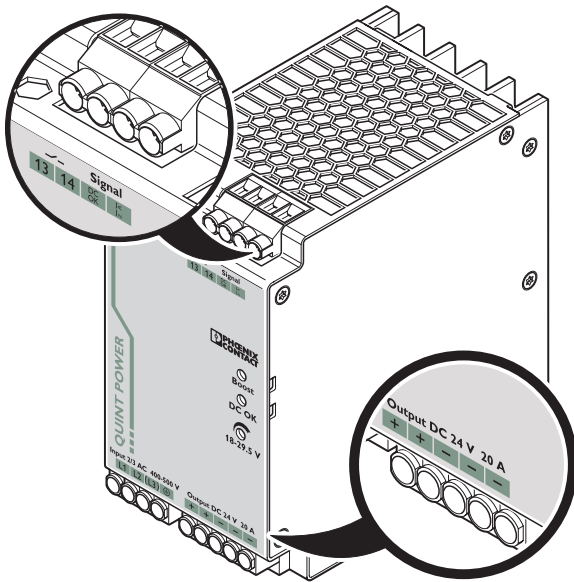

**ATTENTION**

Make sure that all output lines are dimensioned according to the maximum output current or are separately protected. The cables on the secondary side must have sufficiently large cross sections in order to keep the voltage drops on the lines as low as possible.

The connection is established using screw connections on the screw connection of the DC output:  
 24 V DC: "+" and "-"; DC OK switching output active: "DC OK" and "-"; DC OK output floating: "13" and "14"; POWER BOOST switching output active: "I < I<sub>N</sub>" and "-".  
 At the time of delivery, the output voltage is 24 V DC. The output voltage can be set on the potentiometer.

**Protection of the secondary side**

The device is electronically protected against short circuit and idling. In the event of a malfunction, the output voltage is limited to 35 V DC.

### 14 Signaling

An active signal output DC OK, a floating signal contact DC OK and an active signal output POWER BOOST are available for function monitoring. In addition, the DC OK LED and the BOOST LED can be used to evaluate the function of the power supply directly at the installation location (see output characteristic curve).

	$I < I_N$	$I > I_N$	$U_{OUT} < 0.9 \times U_N$
"DC OK" LED	ON	ON	Flashing
"BOOST" LED	OFF	ON	ON
Active DC OK switching output	ON	ON	OFF
Floating DC OK output	Closed	Closed	Open
Active POWER BOOST switching output	ON	OFF	OFF
Meaning	Normal operation of the power supply ( $U_{OUT} > 21.5 \text{ V}$ )	POWER BOOST operation, e.g. to start loads	Overload mode, e.g. consumer short circuit or overload

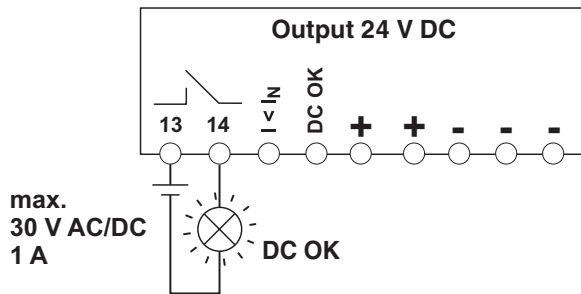

**Floating contact**

The floating signal contact opens and indicates that the set output voltage has undershot by more than 10%. Signals and ohmic loads of up to maximum 30 V and currents of maximum 1 A (or maximum 60 V with maximum 0.5 A) can be switched. For heavily inductive loads such as a relay, a suitable protection circuit (e.g. damping diode) is necessary.

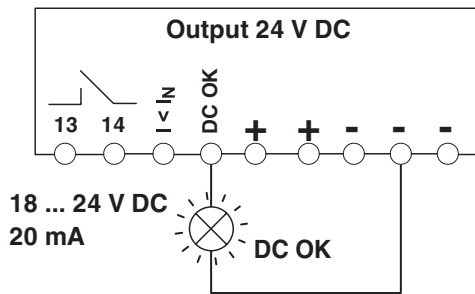

**Active signal outputs**

The 18 ... 24 V DC signal is applied between the "DC OK" and the "-" connection terminal blocks or between "I < I<sub>N</sub>" and "-" and can carry up to 20 mA. By switching from "active high" to "low", the DC OK signal output signalizes when the output voltage is fallen short of by more than 10%. The DC OK signal is decoupled from the power output. This ensures that an external supply does not enter from devices connected in parallel. The POWER BOOST signal output I < I<sub>N</sub> signalizes that the nominal current is exceeded. The power supply unit is then in the POWER BOOST mode. Using this preventive function monitoring, critical operating statuses can be governed at an early stage before it results in a voltage dip. The 18 ... 24 V DC signal can be directly connected to a logic input for evaluation.

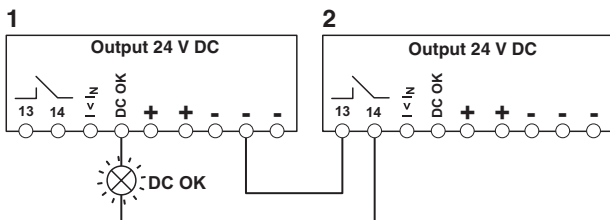

**Signal loop**

Monitoring two devices: Use the active signal output of device 1 and loop in the floating signal output of device 2. In the event of malfunctioning, a common alarm is output. Any number of devices can be looped in. This signal combination saves wiring costs and logic inputs.

15 Function

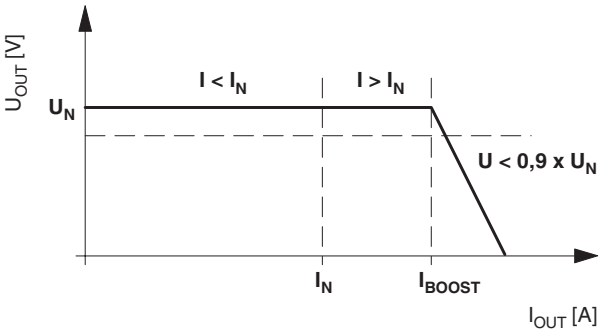

Output characteristic curve

The power supply unit works with the static power reserve POWER BOOST as shown in the U/I characteristic curve in the figure. At ambient temperatures  $T_{amb} < +40\text{ }^\circ\text{C}$ ,  $I_{BOOST}$  is available continuously. At higher temperatures, it's available for a few minutes. In the event of a secondary-side short circuit or overload, the output current is limited to  $I_{BOOST}$ . Thereby, the module does not switch off, but rather supplies a continuous output current. The secondary voltage is reduced here until the short circuit is eliminated. The U/I characteristic curve with the power reserve POWER BOOST ensures that both high inrush currents of capacitive loads as well as consumers with DC/DC converters in the primary circuit can be supplied.

In order to trip standard power circuit breakers magnetically and very quickly, power supply units must supply a multiple of their nominal current for a short period.

As can be seen from the characteristic curve, when  $I < I_N$ ,  $I > I_N$  and  $U < 0.9 \times U_N$ . The relevant signaling can be found in the table "Signaling".

- $U_N = 24\text{ V}$
- $I_N = 20\text{ A}$
- $I_{BOOST} = 26\text{ A}$
- SFB technology = 120 A
- $P_N = 480\text{ W}$
- $P_{BOOST} = 625\text{ W}$

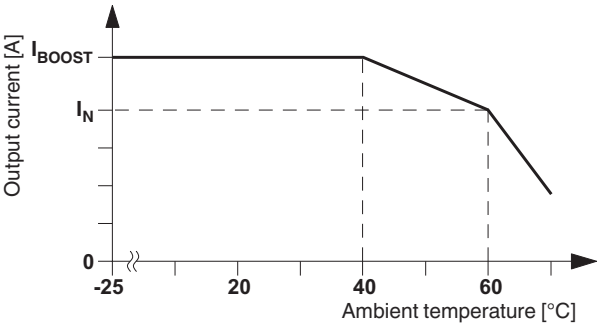

Thermal behavior

With an ambient temperature of up to  $+40\text{ }^\circ\text{C}$ , the device supplies the continuous output current of  $I_{BOOST}$ . The device can supply a nominal output current of  $I_N$  with ambient temperatures of up to  $+60\text{ }^\circ\text{C}$ . In the case of ambient temperatures above  $+60\text{ }^\circ\text{C}$ , the output current must be reduced by 2.5% per Kelvin increase in temperature. The device does not switch off at ambient temperatures of  $+70\text{ }^\circ\text{C}$  or thermal overload. The output capacity is reduced as far as necessary to provide device protection. After it has cooled down, the output capacity is increased again.

**Parallel operation**

Devices of the same type can be connected in parallel to enable both redundancy and an increase in efficiency. On default upon delivery, a further adjustment is not needed. If the output voltage is adjusted, a uniform distribution of power is guaranteed by setting all parallel operated power supply units to exactly the same output voltage. To ensure symmetrical current distribution we recommend that all cable connections from the power supply unit to the busbar are the same length and have the same cross-section! Depending on the system, for parallel connection of more than two power supply units a protective circuit should be installed at each individual device output (e.g. decoupling diode, DC fuse or power circuit breaker). This prevents high return currents in the event of a secondary device fault.

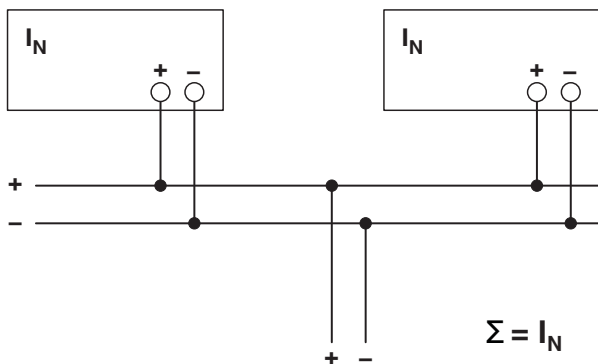

**Redundant operation**

Redundant circuits are suitable for the supply of systems which make especially high requirements on the operational safety. If a fault occurs in the primary circuit of the first power supply unit, the second device automatically takes over the entire power supply, without interruption, and vice versa. For this reason, the power supply units to be connected in parallel are dimensioned in such a way that the total current requirement of all consumers can be completely covered by one power supply unit. 100% redundancy makes external decoupling diodes necessary (QUINT-DIODE/40, Order No. 2938963)!

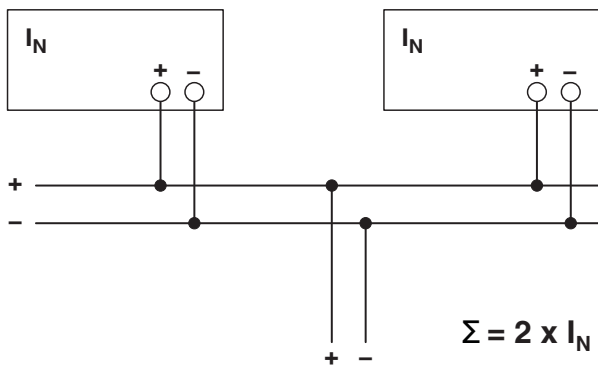

**Increased performance**

For  $n$  parallel connected devices, the output current can be increased to  $n \times I_N$ . Parallel connection for increasing power is used when extending existing systems. A parallel connection is recommended if the power supply unit does not cover the current consumption of the most powerful load. Otherwise the loads should be divided on individual devices independent from each other.

## Данный компонент на территории Российской Федерации

### Вы можете приобрести в компании MosChip.

Для оперативного оформления запроса Вам необходимо перейти по данной ссылке:

<http://moschip.ru/get-element>

Вы можете разместить у нас заказ для любого Вашего проекта, будь то серийное производство или разработка единичного прибора.

В нашем ассортименте представлены ведущие мировые производители активных и пассивных электронных компонентов.

Нашей специализацией является поставка электронной компонентной базы двойного назначения, продукции таких производителей как XILINX, Intel (ex.ALTERA), Vicor, Microchip, Texas Instruments, Analog Devices, Mini-Circuits, Amphenol, Glenair.

Сотрудничество с глобальными дистрибьюторами электронных компонентов, предоставляет возможность заказывать и получать с международных складов практически любой перечень компонентов в оптимальные для Вас сроки.

На всех этапах разработки и производства наши партнеры могут получить квалифицированную поддержку опытных инженеров.

Система менеджмента качества компании отвечает требованиям в соответствии с ГОСТ Р ИСО 9001, ГОСТ РВ 0015-002 и ЭС РД 009

### Офис по работе с юридическими лицами:

105318, г.Москва, ул.Щербаковская д.3, офис 1107, 1118, ДЦ «Щербаковский»

Телефон: +7 495 668-12-70 (многоканальный)

Факс: +7 495 668-12-70 (доб.304)

E-mail: [info@moschip.ru](mailto:info@moschip.ru)

Skype отдела продаж:

moschip.ru

moschip.ru\_4

moschip.ru\_6

moschip.ru\_9