

TRACKER™ NSE-5310 Position Sensor and Evaluation Pack



1 General Description

The TRACKER™ NSE-5310 position sensor is a magnetic sensor array with integrated on-chip digital encoding. With smallest size, 0.5µm resolution and low sensitivity to external magnetic fields, this miniature position sensor is a robust and cost-effective solution for precision positioning.

On-chip encoding provides direct digital output using standard I²C protocol, eliminating the need for external pulse counters. Efficient control system communications allows up to two TRACKER NSE-5310 position sensors for a single I²C bus.

The highest-resolution magnetic encoder available, the TRACKER NSE-5310 position sensor is insensitive to light, shock, vibration, and high-particulate environments.

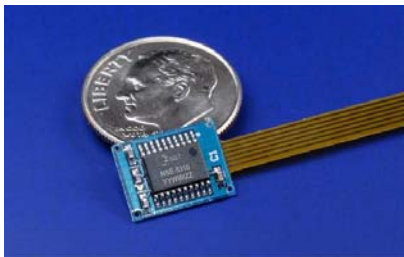

2 Key Features

- Smallest Size: Chip-scale packaging as small as 3.9 x 2.5 mm
- Accurate, Non-contact Sensing: 0.5µm resolution, < 2µm repeatability
- Complete System on a Chip: Sensing and encoding integrated in one ingeniously small package
- Direct Digital Output (I²C): Eliminates need for external pulse counters
- Robust: Insensitive to light, shock, vibration and particulates; less stringent mounting alignment
- Absolute Performance: Zero reference, automatic gain & offset correction

3 Applications

The TRACKER NSE-5310 position sensor is ideal for optical and imaging applications, such as focus and optical image stabilization as well as applications in consumer electronics, precision biomedical devices, industrial instrumentation and defense/security. Its small size makes it perfect for creating tiny, integrated closed-loop motion systems using micro motors, such as New Scale's SQUIGGLE® motor.

Figure 1. TRACKER NSE-5310 Functional Block Diagram

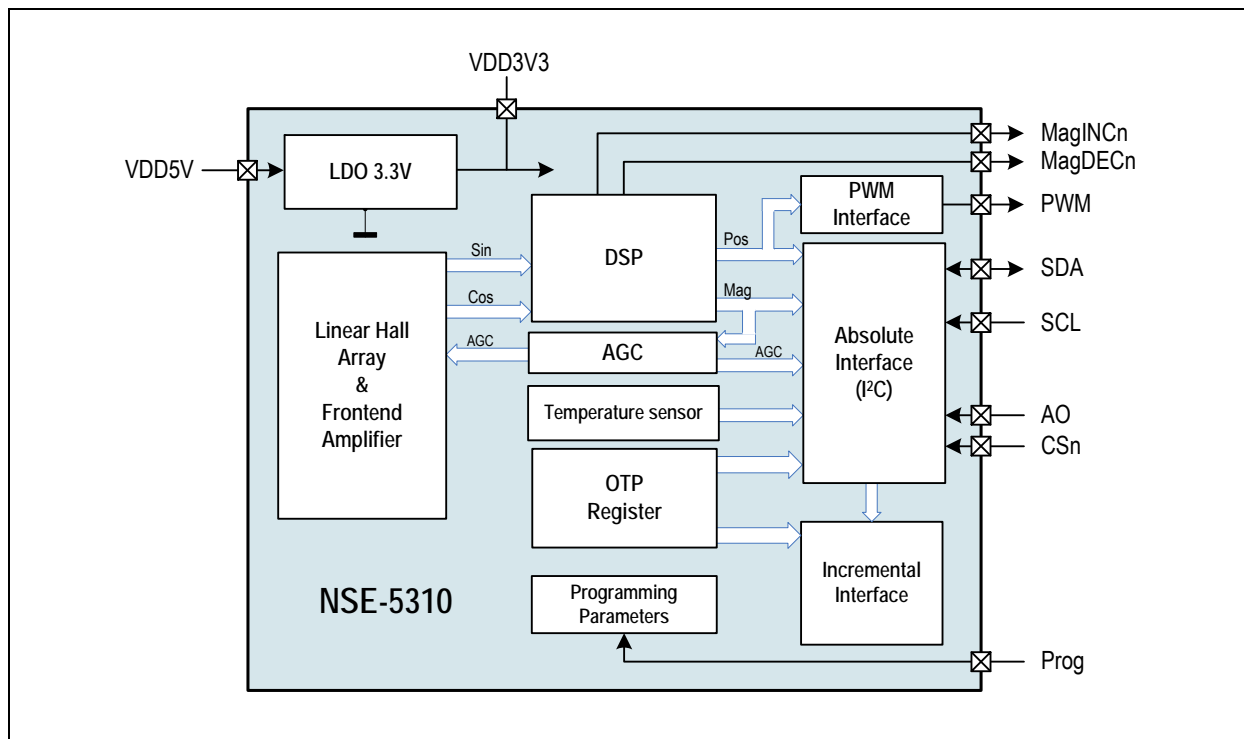

4 Specifications and Operating Conditions

Parameter	Min	Typ	Max	Units	Comments
Supply Voltage VDD3V3	3		3.6	V	
Negative Supply Voltage VSS	0			V	
Supply current			21	mA	
Resolution	0.5 μm @ 12 bits per 2 mm pole pair				
Integral error	$\pm 20 \mu\text{m} < 2\text{mm}$ 1% / 10mm				Error includes magnet error. Magnets supplied by New Scale.
Differential error	$\pm 0.97 \mu\text{m}$ 10bit, no missing codes				
Hysteresis	2-8 LSB				Incremental output, 12-bit resolution
	0				Absolute serial output
I ² C read-out frequency		400	800	kHz	
Operating temperature	-40		+125	°C	
Storage Temperature	-55		125	°C	
Humidity non-condensing	5		85	%	
Thermal Package Resistance (R _{th})			114.5	°C/W	still air

5 System Overview

The TRACKER NSE-5310 magnetic encoder achieves its precision through a linear array of eight Hall-effect sensors on the chip that measure the spatially varying magnetic field produced by moving a multi-pole magnetic strip above the sensor.

The TRK-1T02-E evaluation pack includes a TRACKER NSE-5310 mounted in a TSSOP 20 package with flex cable and a suitable linear magnetic strip, a MC-31MB interface card and New Scale Pathway™ software to facilitate evaluation. The system can be connected to your computer using a USB interface providing direct position information to your application.

TRACKER NSE-5310 in TSSOP or dice-on-foil packaging is available. Custom TRACKER NSE-5310 packaging such as wafer-level chip scale packaging and chip-on-board packaging can also be provided for qualified OEMs. Minimum order quantities may apply.

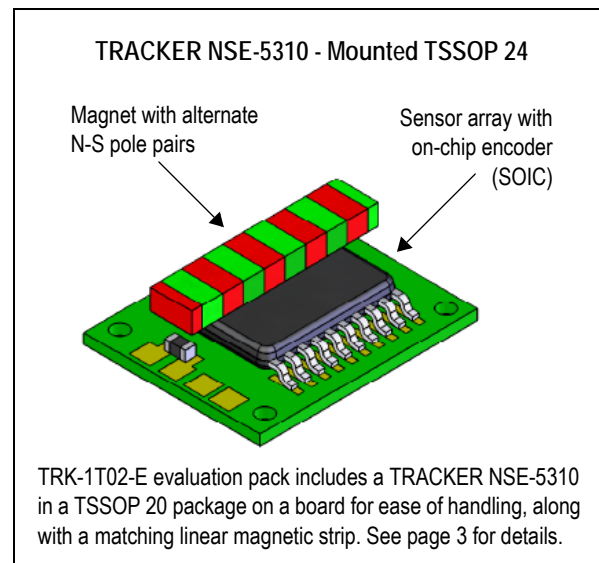

6 Functional Description

Moving a multi-pole magnetic strip over the Hall array on the encoder chip generates internal sinusoidal (SIN) and phase-shifted sinusoidal (COS) signals. These signals are filtered and transformed into angle (ANG) and magnitude (MAG), representing the absolute linear position of a 2mm long pole pair on the magnetic strip. Position information is read via I²C interface (SDA, SCL).

Automatic gain control (AGC) adjusts for DC bias in the magnetic field and provides a large magnetic field dynamic range, for high immunity to external magnetic fields. It also provides an absolute magnitude of the magnetic field intensity, which is used to detect the end of the magnetic strip and thereby serves as a built-in zero reference.

The TRK-1T02-E Evaluation Pack is a full- featured development platform for the TRACKER NSE-5310 Position Sensor. The MC-31MB interface card accepts the I²C input from one or two TRACKER NSE-5310 sensors, and connects via USB to your PC. Use the New Scale Pathway™ Software to view and collect position information. This development kit provides for easy sensor evaluation and system development.

TRK-1T02-E Evaluation Pack



7 Ordering Information

The devices are available as the standard products shown in the table below.

Ordering Code	Description
TRK-1T02	NSE-5310 SOIC TSSOP version on 8.5 x 11.6 mm printed circuit board with flex cable. (Magnet sold separately)
TRK-1T02-E Evaluation Pack	TRK-1T02 position sensor, MC-31MB interface card, power supply, cables, USB cable and New Scale Pathway Software Options: <ul style="list-style-type: none"> - 11mm magnet (for 8mm travel) - Greater than 11mm and less than or equal to 53mm, please contact New Scale.
NSE-5310 SOIC	TSSOP, die-on-foil; contact us for information.

Note: All products are RoHS compliant and Pb-free.

Buy our products or get free samples online at ICdirect: <http://www.austriamicrosystems.com/ICdirect>

Technical Support is available at <http://www.austriamicrosystems.com/Technical-Support>

For further information and requests, please contact us <mailto:sales@austriamicrosystems.com> or find your local distributor at <http://www.austriamicrosystems.com/distributor>

Copyrights

Copyright © 1997-2010, austriamicrosystems AG, Tobelbaderstrasse 30, 8141 Unterpremstaetten, Austria-Europe. Trademarks Registered ©. All rights reserved. The material herein may not be reproduced, adapted, merged, translated, stored, or used without the prior written consent of the copyright owner.

All products and companies mentioned are trademarks or registered trademarks of their respective companies.

Disclaimer

Devices sold by austriamicrosystems AG are covered by the warranty and patent indemnification provisions appearing in its Term of Sale. austriamicrosystems AG makes no warranty, express, statutory, implied, or by description regarding the information set forth herein or regarding the freedom of the described devices from patent infringement. austriamicrosystems AG reserves the right to change specifications and prices at any time and without notice. Therefore, prior to designing this product into a system, it is necessary to check with austriamicrosystems AG for current information. This product is intended for use in normal commercial applications. Applications requiring extended temperature range, unusual environmental requirements, or high reliability applications, such as military, medical life-support or life-sustaining equipment are specifically not recommended without additional processing by austriamicrosystems AG for each application. For shipments of less than 100 parts the manufacturing flow might show deviations from the standard production flow, such as test flow or test location.

The information furnished here by austriamicrosystems AG is believed to be correct and accurate. However, austriamicrosystems AG shall not be liable to recipient or any third party for any damages, including but not limited to personal injury, property damage, loss of profits, loss of use, interruption of business or indirect, special, incidental or consequential damages, of any kind, in connection with or arising out of the furnishing, performance or use of the technical data herein. No obligation or liability to recipient or any third party shall arise or flow out of austriamicrosystems AG rendering of technical or other services.



Contact Information

Headquarters

austriamicrosystems AG
Tobelbaderstrasse 30
A-8141 Unterpremstaetten, Austria

Tel: +43 (0) 3136 500 0
Fax: +43 (0) 3136 525 01

For Sales Offices, Distributors and Representatives, please visit:

<http://www.austriamicrosystems.com/contact>



Contact Information

New Scale Technologies, Inc.
121 Victor Heights Parkway
Victor, NY 14564

Tel: +1 585 924 4450
Fax: +1 585 924 4468

sales@newscaletech.com

www.newscaletech.com

Данный компонент на территории Российской Федерации

Вы можете приобрести в компании MosChip.

Для оперативного оформления запроса Вам необходимо перейти по данной ссылке:

<http://moschip.ru/get-element>

Вы можете разместить у нас заказ для любого Вашего проекта, будь то серийное производство или разработка единичного прибора.

В нашем ассортименте представлены ведущие мировые производители активных и пассивных электронных компонентов.

Нашей специализацией является поставка электронной компонентной базы двойного назначения, продукции таких производителей как XILINX, Intel (ex.ALTERA), Vicor, Microchip, Texas Instruments, Analog Devices, Mini-Circuits, Amphenol, Glenair.

Сотрудничество с глобальными дистрибьюторами электронных компонентов, предоставляет возможность заказывать и получать с международных складов практически любой перечень компонентов в оптимальные для Вас сроки.

На всех этапах разработки и производства наши партнеры могут получить квалифицированную поддержку опытных инженеров.

Система менеджмента качества компании отвечает требованиям в соответствии с ГОСТ Р ИСО 9001, ГОСТ РВ 0015-002 и ЭС РД 009

Офис по работе с юридическими лицами:

105318, г.Москва, ул.Щербаковская д.3, офис 1107, 1118, ДЦ «Щербаковский»

Телефон: +7 495 668-12-70 (многоканальный)

Факс: +7 495 668-12-70 (доб.304)

E-mail: info@moschip.ru

Skype отдела продаж:

moschip.ru

moschip.ru_4

moschip.ru_6

moschip.ru_9