

Super I/O Controller with ACPI Support, Real Time Clock and Consumer IR

FEATURES

- 5 Volt Operation
- PC98/99 and ACPI 1.0 Compliant
- Battery Back-up for Wake-Events
- ISA Plug-and-Play Compatible Register Set
 - 12 IRQ Options
 - 15 Serial IRQ Options
 - 16 Bit Address Qualification
 - Four DMA Options
 - 12mA AT Bus Drivers
- BIOS Buffer
- 20 GPI/O Pins
- 32KHz Standby Clock Output
- Soft Power Management
- ACPI/PME Support
- SCI/SMI Support
 - Watchdog timer
 - Power Button Override Event
 - Either Edge Triggered Interrupts
- Intelligent Auto Power Management
 - Shadowed Write-only Registers
 - Programmable Wake-up Event Interface
- 8042 Keyboard Controller
 - 2K Program ROM
 - 256 Bytes Data RAM
 - Asynchronous Access to Two Data Registers and One Status Register
 - Supports Interrupt and Polling Access
 - 8 Bit Timer/Counter
 - Port 92 Support
 - Fast Gate A20 and Hardware Keyboard Reset
- Real Time Clock
 - Day of Month Alarm, Century Byte
 - MC146818 and DS1287 Compatible
 - 256 Bytes of Battery Backed CMOS in Two Banks of 128 Bytes
- 128 Bytes of CMOS RAM Lockable in 4x32 Byte Blocks
- 12 and 24 Hour Time Format
- Binary and BCD Format
- 5 μ A Standby Battery Current (max)¹
- 2.88MB Super I/O Floppy Disk Controller
 - Relocatable to 480 Different Addresses
 - Licensed CMOS 765B Floppy Disk Controller
 - Advanced Digital Data Separator
 - SMSC's Proprietary 82077AA Compatible Core
 - Sophisticated Power Control Circuitry (PCC) Including Multiple Powerdown Modes for Reduced Power Consumption
 - Supports Two Floppy Drives Directly
 - Software Write Protect
 - FDC on Parallel Port
 - Low Power CMOS Design
 - Supports Vertical Recording Format
 - 16 Byte Data FIFO
 - 100% IBM Compatibility
 - Detects All Overrun and Underrun Conditions
 - 24mA Drivers and Schmitt Trigger Inputs
- Enhanced FDC Digital Data Separator
 - Low Cost Implementation
 - No Filter Components Required
 - 2 Mbps, 1 Mbps, 500 Kbps, 300 Kbps, 250 Kbps Data Rates
 - Programmable Precompensation Modes

- Serial Ports
 - Relocatable to 480 Different Addresses
 - Two High Speed NS16C550 Compatible UARTs with Send/Receive 16 Byte FIFOs
 - Programmable Baud Rate Generator
 - Modem Control Circuitry Including 230K and 460K Baud
 - IrDA 1.0, Consumer IR, HP-SIR, ASK-IR Support
 - Ring Wake Filter
- Multi-Mode Parallel Port with ChiProtect
 - Relocatable to 480 Different Addresses
 - Standard Mode
 - IBM PC/XT, PC/AT, and PS/2 Compatible Bidirectional ParallelPort
 - Enhanced Mode
- Enhanced Parallel Port (EPP) Compatible
- EPP 1.7 and EPP 1.9 (IEEE 1284 Compliant)
- High Speed Mode
- Microsoft and Hewlett Packard Extended Capabilities Port (ECP) Compatible (IEEE 1284 Compliant)
- Incorporates ChiProtect Circuitry for Protection Against Damage Due to Printer Power-On
- 14 mA Output Drivers
- 128 Pin QFP package, lead-free RoHS compliant package also available

Note 1: Please contact SMSC for the latest value.

ORDERING INFORMATION

Order Numbers:

FDC37B787QFP for 128 pin QFP package

FDC37B787-NS for 128 pin QFP lead-free RoHS compliant package

TABLE OF CONTENTS

FEATURES	1
GENERAL DESCRIPTION	6
DESCRIPTION OF PIN FUNCTIONS	7
BUFFER TYPE DESCRIPTIONS	11
REFERENCE DOCUMENTS	13
FUNCTIONAL DESCRIPTION	14
SUPER I/O REGISTERS	14
HOST PROCESSOR INTERFACE	14
FLOPPY DISK CONTROLLER	16
<i>FDC INTERNAL REGISTERS</i>	<i>16</i>
<i>COMMAND SET/DESCRIPTIONS</i>	<i>41</i>
<i>Force Write Protect</i>	<i>70</i>
SERIAL PORT (UART)	70
<i>REGISTER DESCRIPTION</i>	<i>70</i>
INFRARED INTERFACE	88
PARALLEL PORT	88
IBM XT/AT COMPATIBLE, BI-DIRECTIONAL AND EPP MODES	90
EXTENDED CAPABILITIES PARALLEL PORT	96
PARALLEL PORT FLOPPY DISK CONTROLLER	108
POWER MANAGEMENT	110
<i>FDC Power Management</i>	<i>110</i>
<i>UART Power Management</i>	<i>115</i>
<i>Parallel Port</i>	<i>115</i>
<i>V_{BAT} Support</i>	<i>115</i>
<i>V_{TR} Support</i>	<i>115</i>
<i>Internal PWRGOOD</i>	<i>116</i>
<i>CIRCC PLL Power Control</i>	<i>116</i>
<i>32.768 kHz Standby Clock Output</i>	<i>116</i>
BIOS BUFFER	121
GENERAL PURPOSE I/O	123

<i>Description</i>	123
RUN STATE GPIO DATA REGISTER ACCESS	123
GPIO OPERATION	127
8042 KEYBOARD CONTROLLER DESCRIPTION	130
RTC INTERFACE	138
SOFT POWER MANAGEMENT	148
ACPI/PME/SMI FEATURES	152
ACPI Features	152
<i>Wake Events</i>	153
PME SUPPORT	154
ACPI/PME/SMI REGISTERS.....	154
<i>Register Description</i>	154
Wakeup Event Configuration is Retained by Battery Power	156
<i>Register Block</i>	156
ACPI REGISTERS	157
CONFIGURATION	168
SYSTEM ELEMENTS.....	168
<i>Entering the Configuration State</i>	149
<i>Exiting the Configuration State</i>	149
CONFIGURATION SEQUENCE	149
CONFIGURATION REGISTERS	172
<i>Chip Level (Global) Control/Configuration Registers [0x00-0x2F]</i>	176
<i>Logical Device Configuration/Control Registers [0x30-0xFF]</i>	179
<i>Logical Device Registers</i>	179
<i>I/O Base Address Configuration Register</i>	181
<i>Interrupt Select Configuration Register</i>	183
<i>DMA Channel Select Configuration Register</i>	184
SMSC Defined Logical Device Configuration Registers	185
<i>Parallel Port, Logical Device 3</i>	188
<i>Serial Port 1, Logical Device 4</i>	189
<i>Serial Port 2, Logical Device 5</i>	191
<i>RTC, Logical Device 6</i>	192
<i>KYBD, Logical Device 7</i>	193
<i>Auxiliary I/O, Logical Device 8</i>	194
<i>ACPI, Logical Device A</i>	212
OPERATIONAL DESCRIPTION	218
MAXIMUM GUARANTEED RATINGS.....	218
DC ELECTRICAL CHARACTERISTICS.....	218

AC TIMING DIAGRAMS	223
CAPACITIVE LOADING	223
<i>IOW Timing Port 92</i>	224
POWER-UP TIMING	225
<i>Button Timing</i>	226
ROM INTERFACE	227
ISA WRITE	228
ISA READ	229
8042 CPU	231
CLOCK TIMING	232
<i>Burst Transfer DMA Timing</i>	235
DISK DRIVE TIMING	237
SERIAL PORT	238
<i>Parallel Port</i>	239
<i>EPP 1.9 Data or Address Write Cycle</i>	240
<i>EPP 1.9 Data or Address Read Cycle</i>	242
<i>EPP 1.7 Data Or Address Write Cycle</i>	244
<i>EPP 1.7 Data or Address Read Cycle</i>	246
ECP PARALLEL PORT TIMING	249
<i>Serial Port Infrared Timing</i>	254

GENERAL DESCRIPTION

The FDC37B78x with advanced Consumer IR and IrDA v1.0 support incorporates a keyboard interface, real-time clock, SMSC's true CMOS 765B floppy disk controller, advanced digital data separator, 16 byte data FIFO, two 16C550 compatible UARTs, one Multi-Mode parallel port which includes ChiProtect circuitry plus EPP and ECP support, on-chip 12 mA AT bus drivers, and two floppy direct drive support, soft power management and SMI support and Intelligent Power Management including PME and SCI/ACPI support. The true CMOS 765B core provides 100% compatibility with IBM PC/XT and PC/AT architectures in addition to providing data overflow and underflow protection. The SMSC advanced digital data separator incorporates SMSC's patented data separator technology, allowing for ease of testing and use. Both on-chip UARTs are compatible with the NS16C550. The parallel port, the IDE interface, and the game port select logic are compatible with IBM PC/AT architecture, as well as EPP and ECP. The FDC37B78x incorporates sophisticated power control circuitry (PCC) which includes support for keyboard, mouse, modem ring, power button support and consumer infrared wake-up events. The PCC supports multiple low power down modes.

The FDC37B78x provides features for compliance with the "Advanced Configuration and Power Interface Specification" (ACPI).

These features include support of both legacy and ACPI power management models through the selection of SMI or SCI. It implements a power button override event (4 second button hold to turn off the system) and either edge triggered interrupts.

The FDC37B78x provides support for the ISA Plug-and-Play Standard (Version 1.0a) and provides for the recommended functionality to support Windows '95, PC97 and PC98. Through internal configuration registers, each of the FDC37B78x 's logical device's I/O address, DMA channel and IRQ channel may be programmed. There are 480 I/O address location options, 12 IRQ options or Serial IRQ option, and four DMA channel options for each logical device.

The FDC37B78x Floppy Disk Controller and data separator do not require any external filter components and are therefore easy to use, offer lower system cost and reduced board area. The FDC is software and register compatible with SMSC's proprietary 82077AA core.

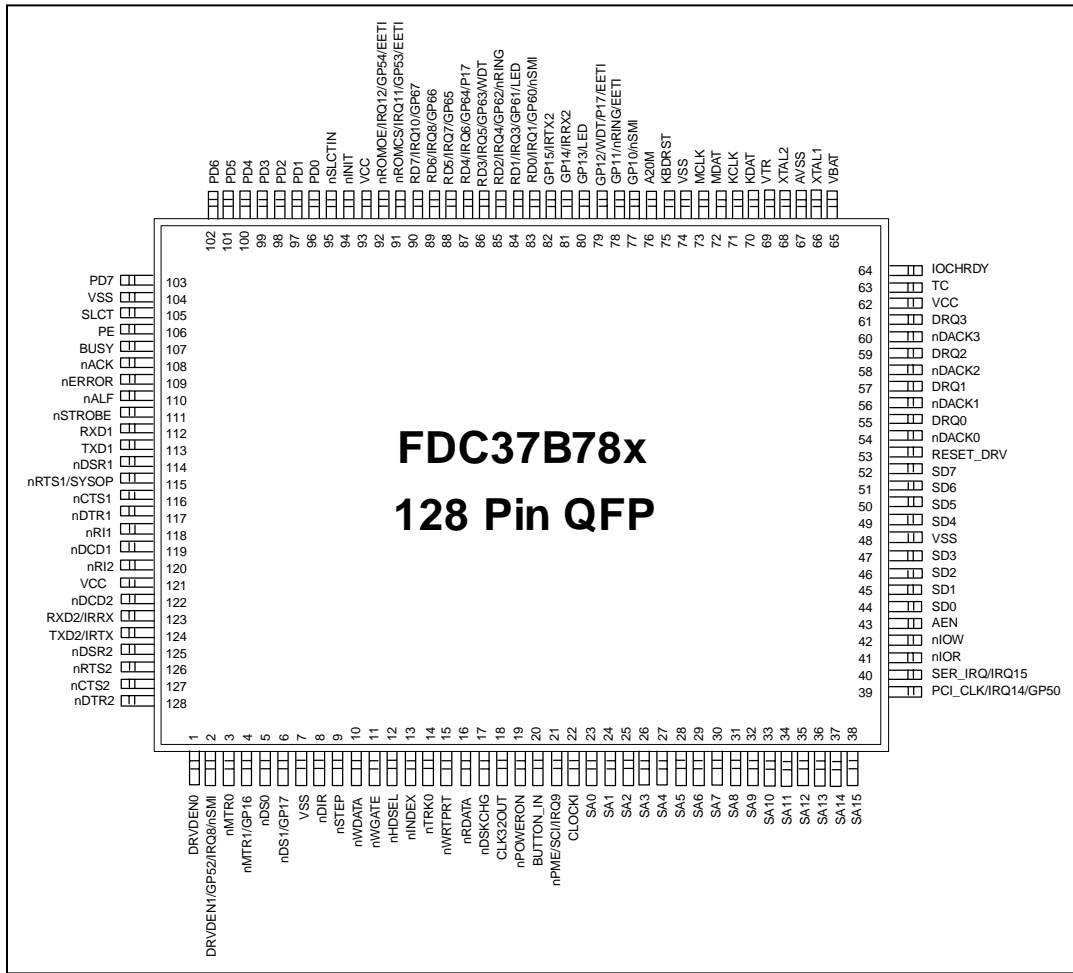

FIGURE 1 - FDC37B78x PIN CONFIGURATION

DESCRIPTION OF PIN FUNCTIONS

PIN No./QFP	NAME	TOTAL	SYMBOL	BUFFER TYPE
PROCESSOR/HOST INTERFACE (40)				
44-47, 49-52	System Data Bus	8	SD[0:7]	IO12
23-38	16-bit System Address Bus	16	SA[0:15]	I
43	Address Enable	1	AEN	I
64	I/O Channel Ready	1	IOCHRDY	OD12
53	ISA Reset Drive	1	RESET_DRV	IS
40	Serial IRQ/IRQ15	1	SER_IRQ	IO12
39	PCI Clock/IRQ14/GP50	1	PCI_CLK	IO12
55	DMA Request 0	1	DRQ0	O12
57	DMA Request 1	1	DRQ1	O12
59	DMA Request 2	1	DRQ2	O12
61	DMA Request 3	1	DRQ3	O12
54	DMA Acknowledge 0	1	nDACK0	I
56	DMA Acknowledge 1	1	nDACK1	I
58	DMA Acknowledge 2	1	nDACK2	I
60	DMA Acknowledge 3	1	nDACK3	I
63	Terminal Count	1	TC	I
41	I/O Read	1	nIOR	I
42	I/O Write	1	nIOW	I
CLOCKS (4)				
22	14.318MHz Clock Input	1	CLOCKI	I
66	32.768kHz Crystal Input	1	XTAL1	ICLK
68	32.768kHz Crystal Driver	1	XTAL2	OCLK
18	32.768kHz Clock Out	1	CLK32OUT	O8
POWER PINS (10)				
62, 93, 121	+5V Supply Voltage	3	VCC	

PIN No./QFP	NAME	TOTAL	SYMBOL	BUFFER TYPE
7, 48, 74, 104	Digital Ground	4	VSS	
67	Analog Ground	1	AVSS	
69	Trickle Supply Voltage	1	VTR	
65	Battery Voltage	1	VBAT	
POWER MANAGEMENT (3)				
19	Power On	1	nPOWERON	OD24
20	Button In	1	BUTTON_IN	I
21	Power Management Event/SCI/IRQ9	1	nPME	O12
FDD INTERFACE (16)				
16	Read Disk Data	1	nRDATA	IS
11	Write Gate	1	nWGATE	O24
10	Write Disk Data	1	nWDATA	O24
12	Head Select	1	nHDSEL	O24
8	Step Direction	1	nDIR	O24
9	Step Pulse	1	nSTEP	O24
17	Disk Change	1	nDSKCHG	IS
5	Drive Select 0	1	nDS0	O24
6	Drive Select 1/GP17	1	nDS1	IO24
3	Motor On 0	1	nMTR0	O24
4	Motor On 1/GP16	1	nMTR1	IO24
15	Write Protected	1	nWRTPRT	IS
14	Track 0	1	nTRKO	IS
13	Index Pulse Input	1	nINDEX	IS
1	Drive Density Select 0	1	DRV DEN0	O24
2	Drive Density Select 1/GP52/IRQ8/nSMI	1	DRV DEN1	IO24
GENERAL PURPOSE I/O (6)				
77	General Purpose 10/nSMI	1	GP10	IO12
78	General Purpose 11/nRING/EETI	1	GP11	IO4

PIN No./QFP	NAME	TOTAL	SYMBOL	BUFFER TYPE
79	General Purpose 12/WDT/P17/EETI	1	GP12	IO4
80	General Purpose 13/LED Driver	1	GP13	IO24
81	General Purpose 14/Infrared Rx	1	GP14	IO4
82	General Purpose 15/Infrared Tx (Note 3)	1	GP15	IO24
BIOS INTERFACE (10)				
83	ROM Bus 0/IRQ1/GP60/nSMI	1	RD0	IO12
84	ROM Bus 1/IRQ3/GP61/LED	1	RD1	IO24
85	ROM Bus 2/IRQ4/GP62/nRING	1	RD2	IO12
86	ROM Bus 3/IRQ5/GP63/WDT	1	RD3	IO12
87	ROM Bus 4/IRQ6/GP64/P17	1	RD4	IO12
88	ROM Bus 5/IRQ7/GP65	1	RD5	IO12
89	ROM Bus 6/IRQ8/GP66	1	RD6	IO12
90	ROM Bus 7/IRQ10/GP67	1	RD7	IO12
91	nROMCS/IRQ11/GP53/EETI	1	nROMCS	IO12
92	nROMOE/IRQ12/GP54/EETI	1	nROMOE	IO12
SERIAL PORT 1 INTERFACE (8)				
112	Receive Serial Data 1	1	RXD1	I
113	Transmit Serial Data 1	1	TXD1	O4
115	Request to Send 1	1	nRTS1/ SYSOP	IO4
116	Clear to Send 1	1	nCTS1	I
117	Data Terminal Ready 1	1	nDTR1	O4
114	Data Set Ready 1	1	nDSR1	I
119	Data Carrier Detect 1	1	nDCD1	I
118	Ring Indicator 1	1	nRI1	I
SERIAL PORT 2 INTERFACE (8)				
123	Receive Serial Data 2/Infrared Rx	1	RXD2/IRRX	I
124	Transmit Serial Data 2/Infrared Tx (Note 3)	1	TXD2/IRTX	O24
126	Request to Send 2	1	nRTS2	O4

PIN No./QFP	NAME	TOTAL	SYMBOL	BUFFER TYPE
127	Clear to Send 2	1	nCTS2	I
128	Data Terminal Ready	1	nDTR2	O4
125	Data Set Ready 2	1	nDSR2	I
122	Data Carrier Detect 2	1	nDCD2	I
120	Ring Indicator 2	1	nRI2	I
PARALLEL PORT INTERFACE (17)				
96-103	Parallel Port Data Bus	8	PD[0:7]	IOP14
95	Printer Select	1	nSLCTIN	OP14
94	Initiate Output	1	nINIT	OP14
110	Auto Line Feed	1	nALF	OP14
111	Strobe Signal	1	nSTROBE	OP14
107	Busy Signal	1	BUSY	I
108	Acknowledge Handshake	1	nACK	I
106	Paper End	1	PE	I
105	Printer Selected	1	SLCT	I
109	Error at Printer	1	nERROR	I
KEYBOARD/MOUSE INTERFACE (6)				
70	Keyboard Data	1	KDAT	IOD16
71	Keyboard Clock	1	KCLK	IOD16
72	Mouse Data	1	MDAT	IOD16
73	Mouse Clock	1	MCLK	IOD16
75	Keyboard Reset	1	KBDRST (Note 2)	O4
76	Gate A20	1	A20M	O4

Note 1 The "n" as the first letter of a signal name indicates an "Active Low" signal.

Note 2 KBDRST is active low.

Note 3 This pin defaults to an output and low.

BUFFER TYPE DESCRIPTIONS

TABLE 1 - BUFFER TYPES

SYMBOL	DESCRIPTION
I	Input, TTL compatible.
IS	Input with Schmitt trigger.
ICLK	RTC 32.768 kHz crystal input.
OCLK	RTC 32.768 kHz crystal output.
IO4	Input/Output, 4mA sink, 2mA source.
O4	Output, 4mA sink, 2mA source.
O8	Output, 8mA sink, 4mA source.
IO12	Input/Output, 12mA sink, 6mA source.
O12	Output, 12mA sink, 6mA source.
OD12	Output, Open Drain, 12 mA sink.
IOP14	Input/Output, 14mA sink, 14mA source. Backdrive Protected.
OD14	Output, Open Drain, 14mA sink.
OP14	Output, 14mA sink, 14mA source. Backdrive Protected.
IOD16	Input/Output, Open Drain, 16mA sink
O24	Output, 24mA sink, 12mA source.
OD24	Output, Open Drain, 24mA sink.
IO24	Input/Output, 24mA sink, 12mA source.

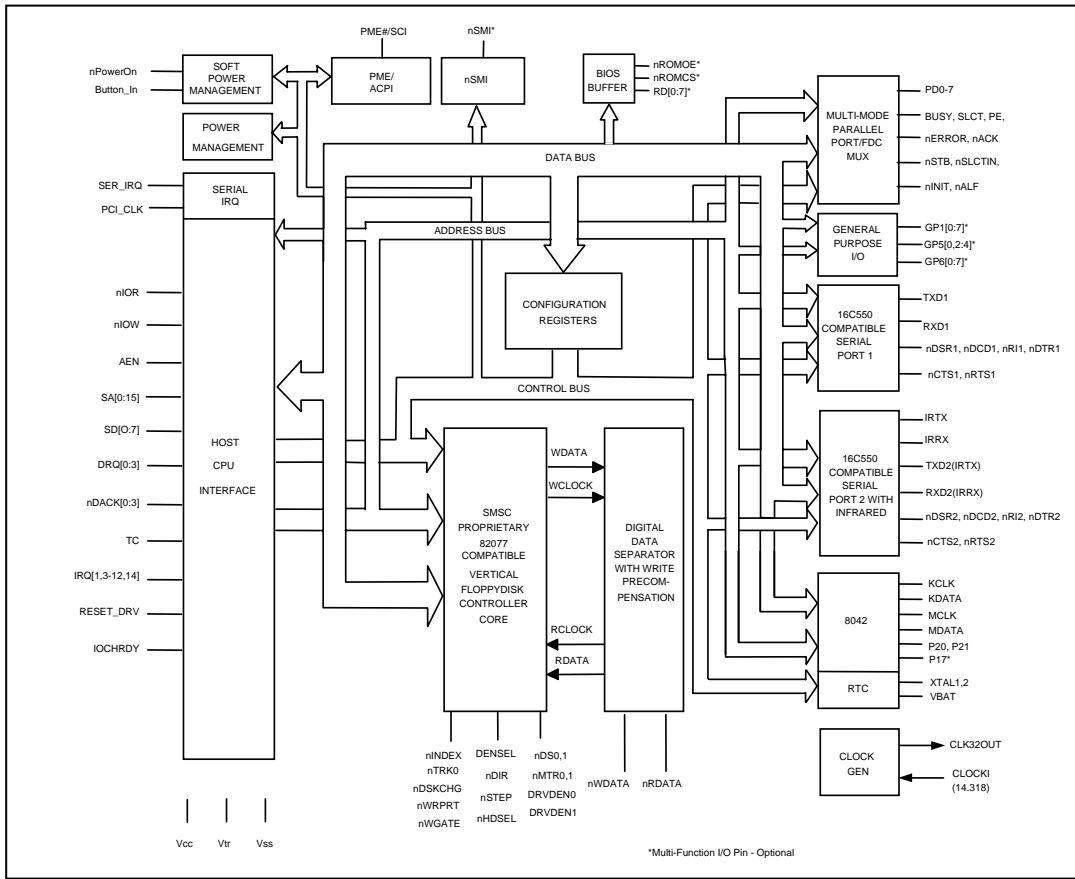

FIGURE 2 - FDC37B78x BLOCK DIAGRAM

GENERAL PURPOSE I/O PINS

TABLE 2 - GENERAL PURPOSE I/O PIN FUNCTIONS

PIN NO. QFP	DEFAULT FUNCT	ALT FUNCT 1	ALT FUNCT 2	ALT FUNCT 3	BUFFER TYPE	INDEX REGISTE R	GPIO
77	GPIO	nSMI	-	-	IO12	GP1	GP10
78	GPIO	nRING	EETI ¹	-	IO4	GP1	GP11
79	GPIO	WDT	P17	EETI ¹	IO4	GP1	GP12
80	GPIO	LED	-	-	IO24	GP1	GP13
81	GPIO	IRRX2	-	-	IO4	GP1	GP14
82	GPIO	IRTX2	-	-	IO24	GP1	GP15
4	nMTR1	GPIO	-	-	IO24	GP1	GP16
6	nDS1	GPIO	-	-	IO24	GP1	GP17
39	PCI_CLK	IRQ14	GPIO	-	IO12	GP5	GP50
2	DRV_DEN1	GPIO	IRQ8	nSMI	IO24	GP5	GP52
91	nROMCS ²	IRQ11	GPIO	EETI ¹	IO12	GP5	GP53
92	nROMOE ²	IRQ12	GPIO	EETI ¹	IO12	GP5	GP54
83	RD0 ^{2,3}	IRQ1	GPIO	nSMI	IO12	GP6	GP60
84	RD1 ^{2,3}	IRQ3	GPIO	LED	IO24	GP6	GP61
85	RD2 ^{2,3}	IRQ4	GPIO	nRING	IO12	GP6	GP62
86	RD3 ^{2,3}	IRQ5	GPIO	WDT	IO12	GP6	GP63
87	RD4 ^{2,3}	IRQ6	GPIO	P17	IO12	GP6	GP64
88	RD5 ^{2,3}	IRQ7	GPIO	-	IO12	GP6	GP65
89	RD6 ^{2,3}	IRQ8	GPIO	-	IO12	GP6	GP66
90	RD7 ^{2,3}	IRQ10	GPIO	-	IO12	GP6	GP67

Note 1 Either Edge Triggered Interrupt Inputs.

Note 2 At power-up, RD0-7, nROMCS and nROMOE function as the XD Bus. To use RD0-7 for alternate functions, nROMCS must stay high until those pins are finished being programmed.

Note 3 These pins cannot be programmed as open drain pins in their original function.

REFERENCE DOCUMENTS

- SMSC Consumer Infrared Communications Controller (CIRCC) V1.X
- IEEE 1284 Extended Capabilities Port Protocol and ISA Standard, Rev. 1.14, July 14, 1993.
- Hardware Description of the 8042, Intel 8 bit Embedded Controller Handbook.
- PCI Bus Power Management Interface Specification, Rev. 1.0, Draft, March 18, 1997.

FUNCTIONAL DESCRIPTION

SUPER I/O REGISTERS

The address map, shown below in Table 4, shows the addresses of the different blocks of the Super I/O immediately after power up. The base addresses of the FDC, serial and parallel ports can be moved via the configuration registers. Some addresses are used to access more than one register.

HOST PROCESSOR INTERFACE

The host processor communicates with the FDC37B78x through a series of read/write registers. The port addresses for these registers are shown in Table 4. Register access is accomplished through programmed I/O or DMA transfers. All registers are 8 bits wide. All host interface output buffers are capable of sinking a minimum of 12 mA.

TABLE 3 - SUPER I/O BLOCK ADDRESSES

ADDRESS	BLOCK NAME	LOGICAL DEVICE	NOTES
Base+(0-5) and +(7)	Floppy Disk	0	
Base+(0-3) Base+(0-7) Base+(0-3), +(400-402) Base+(0-7), +(400-402)	Parallel Port SPP EPP ECP ECP+EPP+SPP	3	
Base+(0-7)	Serial Port Com 1	4	
Base1+(0-7) Base2+(0-7)	Serial Port Com 2	5	IR Support Consumer IR
70,71, Base, Base+(1)	RTC	6	
60, 64	KYBD	7	
Base + (0-17h)	ACPI, PME, SMI	A	
Base + (0-1)	Configuration		

Note 1: Refer to the configuration register descriptions for setting the base address.

FLOPPY DISK CONTROLLER

The Floppy Disk Controller (FDC) provides the interface between a host microprocessor and the floppy disk drives. The FDC integrates the functions of the Formatter/Controller, Digital Data Separator, Write Precompensation and Data Rate Selection logic for an IBM XT/AT compatible FDC. The true CMOS 765B core guarantees 100% IBM PC XT/AT compatibility in addition to providing data overflow and underflow protection.

The FDC is compatible to the 82077AA using SMSC's proprietary floppy disk controller core.

FDC INTERNAL REGISTERS

The Floppy Disk Controller contains eight internal registers that facilitate the interfacing between the host microprocessor and the disk drive. TABLE 4 shows the addresses required to access these registers. Registers other than the ones shown are not supported. The rest of the description assumes that the primary addresses have been selected.

TABLE 4 - STATUS, DATA AND CONTROL REGISTERS

(Shown with base addresses of 3F0 and 370)

PRIMARY ADDRESS	SECONDARY ADDRESS	R/W	REGISTER
3F0	370	R	Status Register A (SRA)
3F1	371	R	Status Register B (SRB)
3F2	372	R/W	Digital Output Register (DOR)
3F3	373	R/W	Tape Drive Register (TSR)
3F4	374	R	Main Status Register (MSR)
3F4	374	W	Data Rate Select Register (DSR)
3F5	375	R/W	Data (FIFO)
3F6	376		Reserved
3F7	377	R	Digital Input Register (DIR)
3F7	377	W	Configuration Control Register (CCR)

STATUS REGISTER A (SRA)

Address 3F0 READ ONLY

This register is read-only and monitors the state of the FINTR pin and several disk interface pins in PS/2 and Model 30 modes. The SRA can be accessed at any time when in PS/2 mode. In the PC/AT mode the data bus pins D0 - D7 are held in a high impedance state for a read of address 3F0.

PS/2 Mode

	7	6	5	4	3	2	1	0
	INT PENDING	nDRV2	STEP	nTRK0	HDSEL	nINDX	nWP	DIR
RESET COND.	0	1	0	N/A	0	N/A	N/A	0

BIT 0 DIRECTION

Active high status indicating the direction of head movement. A logic "1" indicates inward direction; a logic "0" indicates outward direction.

BIT 1 nWRITE PROTECT

Active low status of the WRITE PROTECT disk interface input. A logic "0" indicates that the disk is write protected. (See also Force Write Protect Function)

BIT 2 nINDEX

Active low status of the INDEX disk interface input.

BIT 3 HEAD SELECT

Active high status of the HDSEL disk interface input. A logic "1" selects side 1 and a logic "0" selects side 0.

BIT 4 nTRACK 0

Active low status of the TRK0 disk interface input.

BIT 5 STEP

Active high status of the STEP output disk interface output pin.

BIT 6 nDRV2

Active low status of the DRV2 disk interface input pin, indicating that a second drive has been installed. Note: **This function is not supported in this chip. (Always 1, indicating 1 drive)**

BIT 7 INTERRUPT PENDING

Active high bit indicating the state of the Floppy Disk Interrupt output.

PS/2 Model 30 Mode

	7	6	5	4	3	2	1	0
	INT PENDING	DRQ	STEP F/F	TRK0	nHDSEL	INDX	WP	nDIR
RESET COND.	0	0	0	N/A	1	N/A	N/A	1

BIT 0 nDIRECTION

Active low status indicating the direction of head movement. A logic "0" indicates inward direction; a logic "1" indicates outward direction.

BIT 1 WRITE PROTECT

Active high status of the WRITE PROTECT disk interface input. A logic "1" indicates that the disk is write protected. (See also Force Write Protect Function)

BIT 2 INDEX

Active high status of the INDEX disk interface input.

BIT 3 nHEAD SELECT

Active low status of the HDSEL disk interface input. A logic "0" selects side 1 and a logic "1" selects side 0.

BIT 4 TRACK 0

Active high status of the TRK0 disk interface input.

BIT 5 STEP

Active high status of the latched STEP disk interface output pin. This bit is latched with the STEP output going active, and is cleared with a read from the DIR register, or with a hardware or software reset.

BIT 6 DMA REQUEST

Active high status of the DRQ output pin.

BIT 7 INTERRUPT PENDING

Active high bit indicating the state of the Floppy Disk Interrupt output.

STATUS REGISTER B (SRB)

Address 3F1 READ ONLY

This register is read-only and monitors the state of several disk interface pins in PS/2 and Model 30 modes. The SRB can be accessed at any time when in PS/2 mode. In the PC/AT mode the data bus pins D0 - D7 are held in a high impedance state for a read of address 3F1.

PS/2 Mode

	7	6	5	4	3	2	1	0
	1	1	DRIVE SEL0	WDATA TOGGLE	RDATA TOGGLE	WGATE	MOT EN1	MOT EN0
RESET COND.	1	1	0	0	0	0	0	0

BIT 0 MOTOR ENABLE 0

Active high status of the MTR0 disk interface output pin. This bit is low after a hardware reset and unaffected by a software reset.

BIT 1 MOTOR ENABLE 1

Active high status of the MTR1 disk interface output pin. This bit is low after a hardware reset and unaffected by a software reset.

BIT 2 WRITE GATE

Active high status of the WGATE disk interface output.

BIT 3 READ DATA TOGGLE

Every inactive edge of the RDATA input causes this bit to change state.

BIT 4 WRITE DATA TOGGLE

Every inactive edge of the WDATA input causes this bit to change state.

BIT 5 DRIVE SELECT 0

Reflects the status of the Drive Select 0 bit of the DOR (address 3F2 bit 0). This bit is cleared after a hardware reset and it is unaffected by a software reset.

BIT 6 RESERVED

Always read as a logic "1".

BIT 7 RESERVED

Always read as a logic "1".

PS/2 Model 30 Mode

	7	6	5	4	3	2	1	0
	nDRV2	nDS1	nDS0	WDATA F/F	RDATA F/F	WGATE F/F	nDS3	nDS2
RESET COND.	N/A	1	1	0	0	0	1	1

BIT 0 nDRIVE SELECT 2

The DS2 disk interface is not supported. (Always 1)

BIT 1 nDRIVE SELECT 3

The DS3 disk interface is not supported. (Always 1)

BIT 2 WRITE GATE

Active high status of the latched WGATE output signal. This bit is latched by the active going edge of WGATE and is cleared by the read of the DIR register.

BIT 3 READ DATA

Active high status of the latched RDATA output signal. This bit is latched by the inactive going

edge of RDATA and is cleared by the read of the DIR register.

BIT 4 WRITE DATA

Active high status of the latched WDATA output signal. This bit is latched by the inactive going edge of WDATA and is cleared by the read of the DIR register. This bit is not gated with WGATE.

BIT 5 nDRIVE SELECT 0

Active low status of the DS0 disk interface output.

BIT 6 nDRIVE SELECT 1

Active low status of the DS1 disk interface output.

BIT 7 nDRV2

Active low status of the DRV2 disk interface input, this is not supported. (Always 1)

DIGITAL OUTPUT REGISTER (DOR)

Address 3F2 READ/WRITE

The DOR controls the drive select and motor enables of the disk interface outputs. It also contains the enable for the DMA logic and a software reset bit. The contents of the DOR are unaffected by a software reset. The DOR can be written to at any time.

	7	6	5	4	3	2	1	0
	MOT EN3	MOT EN2	MOT EN1	MOT EN0	DMAEN	nRESE T	DRIVE SEL1	DRIVE SELO
RESET COND.	0	0	0	0	0	0	0	0

BIT 0 and 1 DRIVE SELECT

These two bits are binary encoded for the drive selects, thereby allowing only one drive to be selected at one time.

BIT 2 nRESET

A logic "0" written to this bit resets the Floppy disk controller. This reset will remain active until a logic "1" is written to this bit. This software reset does not affect the DSR and CCR registers, nor does it affect the other bits of the DOR register. The minimum reset duration required is 100ns, therefore toggling this bit by consecutive writes to this register is a valid method of issuing a software reset.

BIT 3 DMAEN

PC/AT and Model 30 Mode:

Writing this bit to logic "1" will enable the DRQ, nDACK, TC and FINTR outputs. This bit being a logic "0" will disable the nDACK and TC inputs, and hold the DRQ and FINTR outputs in a high

impedance state. This bit is a logic "0" after a reset and in these modes.

PS/2 Mode: In this mode the DRQ, nDACK, TC and FINTR pins are always enabled. During a reset, the DRQ, nDACK, TC, and FINTR pins will remain enabled, but this bit will be cleared to a logic "0".

BIT 4 MOTOR ENABLE 0

This bit controls the MTR0 disk interface output. A logic "1" in this bit will cause the output pin to go active.

BIT 5 MOTOR ENABLE 1

This bit controls the MTR1 disk interface output. A logic "1" in this bit will cause the output pin to go active.

BIT 6 MOTOR ENABLE 2

The MTR2 disk interface output is not. (Always 0)

BIT 7 MOTOR ENABLE 3

The MTR3 disk interface output is not. (Always 0)

Table 6 - Drive Activation Values

DRIVE	DOR VALUE
0	1CH
1	2DH

TAPE DRIVE REGISTER (TDR)

Address 3F3 READ/WRITE

TABLE 7 - TAPE SELECT BITS

TAPE SEL1 (TDR.1)	TAPE SEL0 (TDR.0)	DRIVE SELECTED
0	0	None
0	1	1
1	0	2
1	1	3

The Tape Drive Register (TDR) is included for 82077 software compatibility and allows the user to assign tape support to a particular drive during initialization. Any future references to that drive automatically invokes tape support. The TDR

Tape Select bits TDR.[1:0] determine the tape drive number. TABLE 7 illustrates the Tape Select Bit encoding. Note that drive 0 is the boot device and cannot be assigned tape support. The remaining Tape Drive Register bits TDR.[7:2] are tristated when read. The TDR is unaffected by a software reset.

TABLE 8 - INTERNAL 2 DRIVE DECODE - NORMAL

DIGITAL OUTPUT REGISTER						DRIVE SELECT OUTPUTS (ACTIVE LOW)		MOTOR ON OUTPUTS (ACTIVE LOW)	
Bit 7	Bit 6	Bit 5	Bit 4	Bit 1	Bit 0	nDS1	nDS0	nMTR1	nMTR0
X	X	X	1	0	0	1	0	nBIT 5	nBIT 4
X	X	1	X	0	1	0	1	nBIT 5	nBIT 4
X	1	X	X	1	0	1	1	nBIT 5	nBIT 4
1	X	X	X	1	1	1	1	nBIT 5	nBIT 4
0	0	0	0	X	X	1	1	nBIT 5	nBIT 4

TABLE 9 - INTERNAL 2 DRIVE DECODE - DRIVES 0 AND 1 SWAPPED

DIGITAL OUTPUT REGISTER						DRIVE SELECT OUTPUTS (ACTIVE LOW)		MOTOR ON OUTPUTS (ACTIVE LOW)	
Bit 7	Bit 6	Bit 5	Bit 4	Bit 1	Bit 0	nDS1	nDS0	nMTR1	nMTR0
X	X	X	1	0	0	0	1	nBIT 4	nBIT 5
X	X	1	X	0	1	1	0	nBIT 4	nBIT 5
X	1	X	X	1	0	1	1	nBIT 4	nBIT 5
1	X	X	X	1	1	1	1	nBIT 4	nBIT 5
0	0	0	0	X	X	1	1	nBIT 4	nBIT 5

Normal Floppy Mode

Normal mode. Register 3F3 contains only bits 0 and 1. When this register is read, bits 2 - 7 are a high impedance.

	DB7	DB6	DB5	DB4	DB3	DB2	DB1	DB0
REG 3F3	Tri-state	Tri-state	Tri-state	Tri-state	Tri-state	Tri-state	tape sel1	tape sel0

Enhanced Floppy Mode 2 (OS2)

Register 3F3 for Enhanced Floppy Mode 2 operation.

	DB7	DB6	DB5	DB4	DB3	DB2	DB1	DB0
REG 3F3	Reserved	Reserved	Drive Type ID		Floppy Boot Drive		tape sel1	tape sel0

TABLE 10 - DRIVE TYPE ID

DIGITAL OUTPUT REGISTER		REGISTER 3F3 - DRIVE TYPE ID	
Bit 1	Bit 0	Bit 5	Bit 4
0	0	L0-CRF2 - B1	L0-CRF2 - B0
0	1	L0-CRF2 - B3	L0-CRF2 - B2
1	0	L0-CRF2 - B5	L0-CRF2 - B4
1	1	L0-CRF2 - B7	L0-CRF2 - B6

Note:L0-CRF2-Bx = Logical Device 0, Configuration Register F2, Bit x.

DATA RATE SELECT REGISTER (DSR)

Address 3F4 WRITE ONLY

This register is write only. It is used to program the data rate, amount of write precompensation, power down status, and software reset. The data rate is programmed using the Configuration Control Register (CCR) not the DSR, for PC/AT

and PS/2 Model 30 and Microchannel applications. Other applications can set the data rate in the DSR. The data rate of the floppy controller is the most recent write of either the DSR or CCR. The DSR is unaffected by a software reset. A hardware reset will set the DSR to 02H, which corresponds to the default precompensation setting and 250 Kbps.

	7	6	5	4	3	2	1	0
	S/W RESET	POWER DOWN	0	PRE- COMP2	PRE- COMP1	PRE- COMP0	DRATE SEL1	DRATE SEL0
RESET COND.	0	0	0	0	0	0	1	0

BIT 0 and 1 DATA RATE SELECT

These bits control the data rate of the floppy controller. See Table 11 for the settings corresponding to the individual data rates. The data rate select bits are unaffected by a software reset, and are set to 250 Kbps after a hardware reset.

BIT 2 through 4 PRECOMPENSATION SELECT

These three bits select the value of write precompensation that will be applied to the WDATA output signal. Table 10 shows the precompensation values for the combination of these bits settings. Track 0 is the default starting track number to start precompensation. this starting track number can be changed by the configure command.

BIT 5 UNDEFINED

Should be written as a logic "0".

BIT 6 LOW POWER

A logic "1" written to this bit will put the floppy controller into manual low power mode. The floppy controller clock and data mode after a software reset or access to the Data Register or Main Status Register.

BIT 7 SOFTWARE RESET

This active high bit has the same function as the DOR RESET (DOR bit 2) except that this bit is self clearing.

Note: The DSR is Shadowed in the Floppy Data Rate Select Shadow Register, LD8:CR2[7:0]. separator circuits will be turned off. The controller will come out of manual low power.

TABLE 11 - PRECOMPENSATION DELAYS

PRECOMP 432	PRECOMPENSATION DELAY (nsec)	
	<2Mbps	2Mbps
111	0.00	0
001	41.67	20.8
010	83.34	41.7
011	125.00	62.5
100	166.67	83.3
101	208.33	104.2
110	250.00	125
000	Default	Default

Default: See Table 14

TABLE 12 - DATA RATES

DRIVE RATE		DATA RATE		DATA RATE		DENSEL	DRATE(1)	
DRT1	DRT0	SEL1	SEL0	MFM	FM		1	0
0	0	1	1	1Meg	---	1	1	1
0	0	0	0	500	250	1	0	0
0	0	0	1	300	150	0	0	1
0	0	1	0	250	125	0	1	0
0	1	1	1	1Meg	---	1	1	1
0	1	0	0	500	250	1	0	0
0	1	0	1	500	250	0	0	1
0	1	1	0	250	125	0	1	0
1	0	1	1	1Meg	---	1	1	1
1	0	0	0	500	250	1	0	0
1	0	0	1	2Meg	---	0	0	1
1	0	1	0	250	125	0	1	0

Drive Rate Table (Recommended)00 = 360K, 1.2M, 720K, 1.44M and 2.88M Vertical Format
 01 = 3-Mode Drive
 10 = 2 Meg Tape

Note 1: The DRATE and DENSEL values are mapped onto the DRV DEN pins.

TABLE 13 - DRVDEN MAPPING

DT1	DT0	DRVDEN1 (1)	DRVDEN0 (1)	DRIVE TYPE
0	0	DRATE0	DENSEL	4/2/1 MB 3.5" 2/1 MB 5.25" FDDS 2/1.6/1 MB 3.5" (3-MODE)
1	0	DRATE0	DRATE1	
0	1	DRATE0	nDENSEL	PS/2
1	1	DRATE1	DRATE0	

TABLE 14 - DEFAULT PRECOMPENSATION DELAYS

DATA RATE	PRECOMPENSATION DELAYS
2 Mbps	20.8 ns
1 Mbps	41.67 ns
500 Kbps	125 ns
300 Kbps	125 ns
250 Kbps	125 ns

MAIN STATUS REGISTER

Address 3F4 READ ONLY

The Main Status Register is a read-only register and indicates the status of the disk controller. The Main Status Register can be read at any time.

7	6	5	4	3	2	1	0
RQM	DIO	NON DMA	CMD BUSY	Reserved	Reserved	DRV1 BUSY	DRV0 BUSY

BIT 0 - 1 DRV x BUSY

These bits are set to 1s when a drive is in the seek portion of a command, including implied and overlapped seeks and recalibrates.

BIT 4 COMMAND BUSY

This bit is set to a 1 when a command is in progress. This bit will go active after the command byte has been accepted and goes inactive at the end of the results phase. If there is no result phase (Seek, Recalibrate commands), this bit is returned to a 0 after the last command byte.

BIT 5 NON-DMA

This mode is selected in the SPECIFY command and will be set to a 1 during the execution phase of a command. This is for polled data transfers and helps differentiate between the data transfer phase and the reading of result bytes.

BIT 6 DIO

Indicates the direction of a data transfer once a RQM is set. A 1 indicates a read and a 0 indicates a write is required.

BIT 7 RQM

Indicates that the host can transfer data if set to a 1. No access is permitted if set to a 0.

The MSR indicates when the disk controller is ready to receive data via the Data Register. It should be read before each byte transferring to or from the data register except in DMA mode. No delay is required when reading the MSR after a data transfer.

DATA REGISTER (FIFO)

Address 3F5 READ/WRITE

All command parameter information, disk data and result status are transferred between the host processor and the floppy disk controller through the Data Register.

Data transfers are governed by the RQM and DIO bits in the Main Status Register.

The Data Register defaults to FIFO disabled mode after any form of reset. This maintains PC/AT hardware compatibility. The default values can be changed through the Configure command (enable full FIFO operation with threshold control). The advantage of the FIFO is that it allows the system a larger DMA latency without causing a disk error. TABLE 15 gives several examples of the delays with a FIFO. The data is based upon the following formula:

$$\text{Threshold \#} \times \left| \frac{1}{\text{DATA RATE}} \times 8 \right| - 1.5 \mu\text{s} = \text{DELAY}$$

At the start of a command, the FIFO action is always disabled and command parameters must be sent based upon the RQM and DIO bit settings. As the command execution phase is entered, the FIFO is cleared of any data to ensure that invalid data is not transferred.

An overrun or underrun will terminate the current command and the transfer of data. Disk writes will complete the current sector by

generating a 00 pattern and valid CRC. Reads that the result phase may be entered.
 require the host to remove the remaining data so

TABLE 15 - FIFO SERVICE DELAY

FIFO THRESHOLD EXAMPLES	MAXIMUM DELAY TO SERVICING AT 2 Mbps DATA RATE
1 byte	$1 \times 4 \mu\text{s} - 1.5 \mu\text{s} = 2.5 \mu\text{s}$
2 bytes	$2 \times 4 \mu\text{s} - 1.5 \mu\text{s} = 6.5 \mu\text{s}$
8 bytes	$8 \times 4 \mu\text{s} - 1.5 \mu\text{s} = 30.5 \mu\text{s}$
15 bytes	$15 \times 4 \mu\text{s} - 1.5 \mu\text{s} = 58.5 \mu\text{s}$

FIFO THRESHOLD EXAMPLES	MAXIMUM DELAY TO SERVICING AT 1 Mbps DATA RATE
1 byte	$1 \times 8 \mu\text{s} - 1.5 \mu\text{s} = 6.5 \mu\text{s}$
2 bytes	$2 \times 8 \mu\text{s} - 1.5 \mu\text{s} = 14.5 \mu\text{s}$
8 bytes	$8 \times 8 \mu\text{s} - 1.5 \mu\text{s} = 62.5 \mu\text{s}$
15 bytes	$15 \times 8 \mu\text{s} - 1.5 \mu\text{s} = 118.5 \mu\text{s}$

FIFO THRESHOLD EXAMPLES	MAXIMUM DELAY TO SERVICING AT 500 Kbps DATA RATE
1 byte	$1 \times 16 \mu\text{s} - 1.5 \mu\text{s} = 14.5 \mu\text{s}$
2 bytes	$2 \times 16 \mu\text{s} - 1.5 \mu\text{s} = 30.5 \mu\text{s}$
8 bytes	$8 \times 16 \mu\text{s} - 1.5 \mu\text{s} = 126.5 \mu\text{s}$
15 bytes	$15 \times 16 \mu\text{s} - 1.5 \mu\text{s} = 238.5 \mu\text{s}$

DIGITAL INPUT REGISTER (DIR)

Address 3F7 READ ONLY

This register is read-only in all modes.

PC-AT Mode

	7	6	5	4	3	2	1	0
	DSK CHG							
RESET COND.	N/A	N/A	N/A	N/A	N/A	N/A	N/A	N/A

BIT 0 - 6 UNDEFINED

The data bus outputs D0 - 6 will remain in a high impedance state during a read of this register.

BIT 7 DSKCHG

This bit monitors the pin of the same name and reflects the opposite value seen on the disk cable or the value programmed in the Force Disk Change Register (see Configuration Register LD8:CRC1[1:0]).

PS/2 Mode

	7	6	5	4	3	2	1	0
	DSK CHG	1	1	1	1	DRATE SEL1	DRATE SEL0	nHIGH nDENS
RESET COND.	N/A	N/A	N/A	N/A	N/A	N/A	N/A	1

BIT 0 nHIGH DENS

This bit is low whenever the 500 Kbps or 1 Mbps data rates are selected, and high when 250 Kbps and 300 Kbps are selected.

BITS 1 - 2 DATA RATE SELECT

These bits control the data rate of the floppy controller. See Table 11 for the settings corresponding to the individual data rates. The data rate select bits are unaffected by a software reset, and are set to 250 Kbps after a hardware reset.

BITS 3 - 6 UNDEFINED

Always read as a logic "1"

BIT 7 DSKCHG

This bit monitors the pin of the same name and reflects the opposite value seen on the disk cable or the value programmed in the Force Disk Change Register (see Configuration Register LD8:CRC1[1:0]).

Model 30 Mode

	7	6	5	4	3	2	1	0
	DSK CHG	0	0	0	DMAEN	NOPREC	DRATE SEL1	DRATE SELO
RESET COND.	N/A	0	0	0	0	0	1	0

BITS 0 - 1 DATA RATE SELECT

These bits control the data rate of the floppy controller. See Table 14 for the settings corresponding to the individual data rates. The data rate select bits are unaffected by a software reset, and are set to 250 Kbps after a hardware reset.

BIT 2 NOPREC

This bit reflects the value of NOPREC bit set in the CCR register.

BIT 3 DMAEN

This bit reflects the value of DMAEN bit set in the DOR register bit 3.

BITS 4 - 6 UNDEFINED

Always read as a logic "0"

BIT 7 DSKCHG

This bit monitors the pin of the same name and reflects the opposite value seen on the disk cable or the value programmed in the Force Disk Change Register (see Configuration Register LD8:CRC1[1:0]).

CONFIGURATION CONTROL REGISTER (CCR)

Address 3F7 WRITE ONLY
PC/AT and PS/2 Modes

	7	6	5	4	3	2	1	0
							DRATE SEL1	DRATE SEL0
RESET COND.	N/A	N/A	N/A	N/A	N/A	N/A	1	0

BIT 0 and 1 DATA RATE SELECT 0 and 1

These bits determine the data rate of the floppy controller. See Table 14 for the appropriate values.

BIT 2 - 7 RESERVED

Should be set to a logical "0"

PS/2 Model 30 Mode

	7	6	5	4	3	2	1	0
						NOPREC	DRATE SEL1	DRATE SEL0
RESET COND.	N/A	N/A	N/A	N/A	N/A	N/A	1	0

BIT 0 and 1 DATA RATE SELECT 0 and 1

These bits determine the data rate of the floppy controller. See Table 14 for the appropriate values.

BIT 2 NO PRECOMPENSATION

This bit can be set by software, but it has no functionality. It can be read by bit 2 of the DSR when in Model 30 register mode. Unaffected by software reset.

BIT 3 - 7 RESERVED

Should be set to a logical "0"

Table 15 shows the state of the DENSEL pin. The DENSEL pin is set high after a hardware reset and is unaffected by the DOR and the DSR resets.

STATUS REGISTER ENCODING

During the Result Phase of certain commands, the Data Register contains data bytes that give the status of the command just executed.

TABLE 16 - STATUS REGISTER 0

BIT NO.	SYMBOL	NAME	DESCRIPTION
7,6	IC	Interrupt Code	00 - Normal termination of command. The specified command was properly executed and completed without error. 01 - Abnormal termination of command. Command execution was started, but was not successfully completed. 10 - Invalid command. The requested command could not be executed. 11 - Abnormal termination caused by Polling.
5	SE	Seek End	The FDC completed a Seek, Relative Seek or Recalibrate command (used during a Sense Interrupt Command).
4	EC	Equipment Check	The TRK0 pin failed to become a "1" after: 1. 80 step pulses in the Recalibrate command. 2. The Relative Seek command caused the FDC to step outward beyond Track 0.
3			Unused. This bit is always "0".
2	H	Head Address	The current head address.
1,0	DS1,0	Drive Select	The current selected drive.

TABLE 17 - STATUS REGISTER 1

BIT NO.	SYMBOL	NAME	DESCRIPTION
7	EN	End of Cylinder	The FDC tried to access a sector beyond the final sector of the track (255D). Will be set if TC is not issued after Read or Write Data command.
6			Unused. This bit is always "0".
5	DE	Data Error	The FDC detected a CRC error in either the ID field or the data field of a sector.
4	OR	Overrun/Underrun	Becomes set if the FDC does not receive CPU or DMA service within the required time interval, resulting in data overrun or underrun.
3			Unused. This bit is always "0".
2	ND	No Data	Any one of the following: 1. Read Data, Read Deleted Data command - the FDC did not find the specified sector. 2. Read ID command - the FDC cannot read the ID field without an error. 3. Read A Track command - the FDC cannot find the proper sector sequence.
1	NW	Not Writeable	WP pin became a "1" while the FDC is executing a Write Data, Write Deleted Data, or Format A Track command.
0	MA	Missing Address Mark	Any one of the following: 1. The FDC did not detect an ID address mark at the specified track after encountering the index pulse from the IDX pin twice. 2. The FDC cannot detect a data address mark or a deleted data address mark on the specified track.

TABLE 18 - STATUS REGISTER 2

BIT NO.	SYMBOL	NAME	DESCRIPTION
7			Unused. This bit is always "0".
6	CM	Control Mark	Any one of the following: 1. Read Data command - the FDC encountered a deleted data address mark. 2. Read Deleted Data command - the FDC encountered a data address mark.
5	DD	Data Error in Data Field	The FDC detected a CRC error in the data field.
4	WC	Wrong Cylinder	The track address from the sector ID field is different from the track address maintained inside the FDC.
3			Unused. This bit is always "0".
2			Unused. This bit is always "0".
1	BC	Bad Cylinder	The track address from the sector ID field is different from the track address maintained inside the FDC and is equal to FF hex, which indicates a bad track with a hard error according to the IBM soft-sectored format.
0	MD	Missing Data Address Mark	The FDC cannot detect a data address mark or a deleted data address mark.

TABLE 19 - STATUS REGISTER 3

BIT NO.	SYMBOL	NAME	DESCRIPTION
7			Unused. This bit is always "0".
6	WP	Write Protected	Indicates the status of the WP pin.
5			Unused. This bit is always "1".
4	T0	Track 0	Indicates the status of the TRK0 pin.
3			Unused. This bit is always "1".
2	HD	Head Address	Indicates the status of the HDSEL pin.
1,0	DS1,0	Drive Select	Indicates the status of the DS1, DS0 pins.

RESET

There are three sources of system reset on the FDC: the RESET pin of the FDC, a reset generated via a bit in the DOR, and a reset generated via a bit in the DSR. At power on, a Power On Reset initializes the FDC. All resets take the FDC out of the power down state.

All operations are terminated upon a RESET, and the FDC enters an idle state. A reset while a disk write is in progress will corrupt the data and CRC.

On exiting the reset state, various internal registers are cleared, including the Configure command information, and the FDC waits for a new command. Drive polling will start unless disabled by a new Configure command.

RESET Pin (Hardware Reset)

The RESET pin is a global reset and clears all registers except those programmed by the Specify command. The DOR reset bit is enabled and must be cleared by the host to exit the reset state.

DOR Reset vs. DSR Reset (Software Reset)

These two resets are functionally the same.

Both will reset the FDC core, which affects drive status information and the FIFO circuits. The DSR reset clears itself automatically while the DOR reset requires the host to manually clear it. DOR reset has precedence over the DSR reset. The DOR reset is set automatically upon a pin reset. The user must manually clear this reset bit in the DOR to exit the reset state.

MODES OF OPERATION

The FDC has three modes of operation, PC/AT mode, PS/2 mode and Model 30 mode. These are determined by the state of the IDENT and MFM bits 3 and 2 respectively of LD8CRF0.

PC/AT mode - (IDENT high, MFM a "don't care")

The PC/AT register set is enabled, the DMA enable bit of the DOR becomes valid (FINTR and DRQ can be hi Z), and TC and DENSEL become active high signals.

PS/2 mode - (IDENT low, MFM high)

This mode supports the PS/2 models 50/60/80 configuration and register set. The DMA bit of the DOR becomes a "don't care", (FINTR and DRQ are always valid), TC and DENSEL become active low.

Model 30 mode - (IDENT low, MFM low)

This mode supports PS/2 Model 30 configuration and register set. The DMA enable bit of the DOR becomes valid (FINTR and DRQ can be hi Z), TC is active high and DENSEL is active low.

DMA TRANSFERS

DMA transfers are enabled with the Specify command and are initiated by the FDC by activating the FDRQ pin during a data transfer command. The FIFO is enabled directly by asserting nDACK and addresses need not be valid.

Note that if the DMA controller (i.e. 8237A) is programmed to function in verify mode, a pseudo read is performed by the FDC based only on nDACK. This mode is only available when the FDC has been configured into byte mode (FIFO disabled) and is programmed to do a read. With the FIFO enabled, the FDC can perform the above operation by using the new Verify command; no DMA operation is needed.

Two DMA transfer modes are supported for the FDC: Single Transfer and Burst Transfer. In the case of the single transfer, the DMA Req goes active at the start of the DMA cycle, and the DMA Req is deasserted after the nDACK. In the case of the burst transfer, the Req is held active until the last transfer (independent of nDACK). See timing diagrams for more information.

Burst mode is enabled via Bit[1] of CRF0 in Logical Device 0. Setting Bit[1]=0 enables burst mode; the default is Bit[1]=1, for non-burst mode.

CONTROLLER PHASES

For simplicity, command handling in the FDC can be divided into three phases: Command, Execution, and Result. Each phase is described in the following sections.

Command Phase

After a reset, the FDC enters the command phase and is ready to accept a command from the host. For each of the commands, a defined set of

command code bytes and parameter bytes has to be written to the FDC before the command phase is complete. (Please refer to TABLE 20 for the command set descriptions). These bytes of data must be transferred in the order prescribed.

Before writing to the FDC, the host must examine the RQM and DIO bits of the Main Status Register. RQM and DIO must be equal to "1" and "0" respectively before command bytes may be written. RQM is set false by the FDC after each write cycle until the received byte is processed. The FDC asserts RQM again to request each parameter byte of the command unless an illegal command condition is detected. After the last parameter byte is received, RQM remains "0" and the FDC automatically enters the next phase as defined by the command definition.

The FIFO is disabled during the command phase to provide for the proper handling of the "Invalid Command" condition.

Execution Phase

All data transfers to or from the FDC occur during the execution phase, which can proceed in DMA or non-DMA mode as indicated in the Specify command.

After a reset, the FIFO is disabled. Each data byte is transferred by an FINT or FDRQ depending on the DMA mode. The Configure command can enable the FIFO and set the FIFO threshold value.

The following paragraphs detail the operation of the FIFO flow control. In these descriptions, <threshold> is defined as the number of bytes available to the FDC when service is requested from the host and ranges from 1 to 16. The parameter FIFOTHR, which the user programs, is one less and ranges from 0 to 15.

A low threshold value (i.e. 2) results in longer periods of time between service requests, but requires faster servicing of the request for both read and write cases. The host reads (writes) from (to) the FIFO until empty (full), then the transfer request goes inactive. The host must be

very responsive to the service request. This is the desired case for use with a "fast" system.

A high value of threshold (i.e. 12) is used with a "sluggish" system by affording a long latency period after a service request, but results in more frequent service requests.

Non-DMA Mode - Transfers from the FIFO to the Host

The FINT pin and RQM bits in the Main Status Register are activated when the FIFO contains (16-<threshold>) bytes or the last bytes of a full sector have been placed in the FIFO. The FINT pin can be used for interrupt-driven systems, and RQM can be used for polled systems. The host must respond to the request by reading data from the FIFO. This process is repeated until the last byte is transferred out of the FIFO. The FDC will deactivate the FINT pin and RQM bit when the FIFO becomes empty.

Non-DMA Mode - Transfers from the Host to the FIFO

The FINT pin and RQM bit in the Main Status Register are activated upon entering the execution phase of data transfer commands. The host must respond to the request by writing data into the FIFO. The FINT pin and RQM bit remain true until the FIFO becomes full. They are set true again when the FIFO has <threshold> bytes remaining in the FIFO. The FINT pin will also be deactivated if TC and nDACK both go inactive. The FDC enters the result phase after the last byte is taken by the FDC from the FIFO (i.e. FIFO empty condition).

DMA Mode - Transfers from the FIFO to the Host

The FDC activates the DDRQ pin when the FIFO contains (16 - <threshold>) bytes, or the last byte of a full sector transfer has been placed in the FIFO. The DMA controller must respond to the request by reading data from the FIFO. The FDC will deactivate the DDRQ pin when the FIFO becomes empty. FDRQ goes inactive after nDACK goes active for the last byte of a data transfer (or on the active edge of nLOR, on the last byte, if no edge is present on nDACK). A data

underrun may occur if FDRQ is not removed in time to prevent an unwanted cycle.

DMA Mode - Transfers from the Host to the FIFO.

The FDC activates the FDRQ pin when entering the execution phase of the data transfer commands. The DMA controller must respond by activating the nDACK and nLOW pins and placing data in the FIFO. FDRQ remains active until the FIFO becomes full. FDRQ is again set true when the FIFO has <threshold> bytes remaining in the FIFO. The FDC will also deactivate the FDRQ pin when TC becomes true (qualified by nDACK), indicating that no more data is required. FDRQ goes inactive after nDACK goes active for the last byte of a data transfer (or on the active edge of nLOW of the last byte, if no edge is present on nDACK). A data overrun may occur if FDRQ is not removed in time to prevent an unwanted cycle.

Data Transfer Termination

The FDC supports terminal count explicitly through the TC pin and implicitly through the underrun/overrun and end-of-track (EOT) functions. For full sector transfers, the EOT parameter can define the last sector to be transferred in a single or multi-sector transfer.

If the last sector to be transferred is a partial sector, the host can stop transferring the data in mid-sector, and the FDC will continue to complete the sector as if a hardware TC was received. The only difference between these implicit functions and TC is that they return "abnormal termination" result status. Such status indications can be ignored if they were expected.

Note that when the host is sending data to the FIFO of the FDC, the internal sector count will be complete when the FDC reads the last byte from its side of the FIFO. There may be a delay in the removal of the transfer request signal of up to the time taken for the FDC to read the last 16 bytes from the FIFO. The host must tolerate this delay.

Result Phase

The generation of FINT determines the beginning of the result phase. For each of the commands, a defined set of result bytes has to be read from the FDC before the result phase is complete. These bytes of data must be read out for another command to start.

RQM and DIO must both equal "1" before the result bytes may be read. After all the result bytes have been read, the RQM and DIO bits switch to "1" and "0" respectively, and the CB bit is cleared, indicating that the FDC is ready to accept the next command.

COMMAND SET/DESCRIPTIONS

Commands can be written whenever the FDC is in the command phase. Each command has a unique set of needed parameters and status results. The FDC checks to see that the first byte is a valid command and, if valid, proceeds with the command. If it is invalid, an interrupt is issued.

The user sends a Sense Interrupt Status command which returns an invalid command error. Refer to TABLE 20 for explanations of the various symbols used. TABLE 21 lists the required parameters and the results associated with each command that the FDC is capable of performing.

TABLE 20 - DESCRIPTION OF COMMAND SYMBOLS

SYMBOL	NAME	DESCRIPTION									
C	Cylinder Address	The currently selected address; 0 to 255.									
D	Data Pattern	The pattern to be written in each sector data field during formatting.									
D0, D1	Drive Select 0-1	Designates which drives are perpendicular drives on the Perpendicular Mode Command. A "1" indicates a perpendicular drive.									
DIR	Direction Control	If this bit is 0, then the head will step out from the spindle during a relative seek. If set to a 1, the head will step in toward the spindle.									
DS0, DS1	Disk Drive Select	<table style="width: 100%; border-collapse: collapse;"> <tr> <td style="text-align: center; border-bottom: 1px solid black;">DS1</td> <td style="text-align: center; border-bottom: 1px solid black;">DS0</td> <td style="text-align: center; border-bottom: 1px solid black;">Drive Selected</td> </tr> <tr> <td style="text-align: center;">0</td> <td style="text-align: center;">0</td> <td style="text-align: center;">Drive 0</td> </tr> <tr> <td style="text-align: center;">0</td> <td style="text-align: center;">1</td> <td style="text-align: center;">Drive 1</td> </tr> </table>	DS1	DS0	Drive Selected	0	0	Drive 0	0	1	Drive 1
DS1	DS0	Drive Selected									
0	0	Drive 0									
0	1	Drive 1									
DTL	Special Sector Size	By setting N to zero (00), DTL may be used to control the number of bytes transferred in disk read/write commands. The sector size (N = 0) is set to 128. If the actual sector (on the diskette) is larger than DTL, the remainder of the actual sector is read but is not passed to the host during read commands; during write commands, the remainder of the actual sector is written with all zero bytes. The CRC check code is calculated with the actual sector. When N is not zero, DTL has no meaning and should be set to FF HEX.									
EC	Enable Count	When this bit is "1" the "DTL" parameter of the Verify command becomes SC (number of sectors per track).									
EFIFO	Enable FIFO	This active low bit when a 0, enables the FIFO. A "1" disables the FIFO (default).									
EIS	Enable Implied Seek	When set, a seek operation will be performed before executing any read or write command that requires the C parameter in the command phase. A "0" disables the implied seek.									
EOT	End of Track	The final sector number of the current track.									
GAP		Alters Gap 2 length when using Perpendicular Mode.									
GPL	Gap Length	The Gap 3 size. (Gap 3 is the space between sectors excluding the VCO synchronization field).									
H/HDS	Head Address	Selected head: 0 or 1 (disk side 0 or 1) as encoded in the sector ID field.									

SYMBOL	NAME	DESCRIPTION
HLT	Head Load Time	The time interval that FDC waits after loading the head and before initializing a read or write operation. Refer to the Specify command for actual delays.
HUT	Head Unload Time	The time interval from the end of the execution phase (of a read or write command) until the head is unloaded. Refer to the Specify command for actual delays.
LOCK		Lock defines whether EFIFO, FIFOTHR, and PRETRK parameters of the CONFIGURE COMMAND can be reset to their default values by a "software Reset". (A reset caused by writing to the appropriate bits of either the DSR or DOR)
MFM	MFM/FM Mode Selector	A one selects the double density (MFM) mode. A zero selects single density (FM) mode.

TABLE 21 - DESCRIPTION OF COMMAND SYMBOLS

MT	Multi-Track Selector	When set, this flag selects the multi-track operating mode. In this mode, the FDC treats a complete cylinder under head 0 and 1 as a single track. The FDC operates as this expanded track started at the first sector under head 0 and ended at the last sector under head 1. With this flag set, a multitrack read or write operation will automatically continue to the first sector under head 1 when the FDC finishes operating on the last sector under head 0.
N	Sector Size Code	This specifies the number of bytes in a sector. If this parameter is "00", then the sector size is 128 bytes. The number of bytes transferred is determined by the DTL parameter. Otherwise the sector size is (2 raised to the "N'th" power) times 128. All values up to "07" hex are allowable. "07" would equal a sector size of 16k. It is the user's responsibility to not select combinations that are not possible with the drive. <u>N Sector Size</u> 0 128 Bytes 1 256 Bytes 2 512 Bytes 3 1024 Bytes
NCN	New Cylinder Number	The desired cylinder number.
ND	Non-DMA Mode Flag	When set to 1, indicates that the FDC is to operate in the non-DMA mode. In this mode, the host is interrupted for each data transfer. When set to 0, the FDC operates in DMA mode, interfacing to a DMA controller by means of the DRQ and nDACK signals.
OW	Overwrite	The bits D0-D3 of the Perpendicular Mode Command can only be modified if OW is set to 1. OW is defined in the Lock command.
PCN	Present Cylinder Number	The current position of the head at the completion of Sense Interrupt Status command.

TABLE 21 - DESCRIPTION OF COMMAND SYMBOLS

POLL	Polling Disable	When set, the internal polling routine is disabled. When clear, polling is enabled.
PRETRK	Precompensation Start Track Number	Programmable from track 00 to FFH.
R	Sector Address	The sector number to be read or written. In multi-sector transfers, this parameter specifies the sector number of the first sector to be read or written.
RCN	Relative Cylinder Number	Relative cylinder offset from present cylinder as used by the Relative Seek command.
SC	Number of Sectors Per Track	The number of sectors per track to be initialized by the Format command. The number of sectors per track to be verified during a Verify command when EC is set.
SK	Skip Flag	When set to 1, sectors containing a deleted data address mark will automatically be skipped during the execution of Read Data. If Read Deleted is executed, only sectors with a deleted address mark will be accessed. When set to "0", the sector is read or written the same as the read and write commands.
SRT	Step Rate Interval	The time interval between step pulses issued by the FDC. Programmable from 0.5 to 8 milliseconds in increments of 0.5 ms at the 1 Mbit data rate. Refer to the SPECIFY command for actual delays.
ST0 ST1 ST2 ST3	Status 0 Status 1 Status 2 Status 3	Registers within the FDC which store status information after a command has been executed. This status information is available to the host during the result phase after command execution.
WGATE	Write Gate	Alters timing of WE to allow for pre-erase loads in perpendicular drives.

INSTRUCTION SET

TABLE 22 - INSTRUCTION SET

READ DATA											
PHASE	R/W	DATA BUS								REMARKS	
		D7	D6	D5	D4	D3	D2	D1	D0		
Command	W	MT	MFM	SK	0	0	1	1	0	Command Codes Sector ID information prior to Command execution.	
	W	0	0	0	0	0	HDS	DS1	DS0		
	W										----- C -----
	W										----- H -----
	W										----- R -----
	W										----- N -----
	W										----- EOT -----
	W										----- GPL ----- ----- DTL -----
Execution										Data transfer between the FDD and system.	
Result	R									----- ST0 -----	Status information after Command execution.
	R									----- ST1 -----	
	R									----- ST2 -----	
	R									----- C -----	Sector ID information after Command execution.
	R									----- H -----	
	R									----- R -----	
	R									----- N -----	

READ DELETED DATA										
PHASE	R/W	DATA BUS								REMARKS
		D7	D6	D5	D4	D3	D2	D1	D0	
Command	W	MT	MFM	SK	0	1	1	0	0	Command Codes Sector ID information prior to Command execution.
	W	0	0	0	0	0	HDS	DS1	DS0	
	W				-----	C	-----			
	W				-----	H	-----			
	W				-----	R	-----			
	W				-----	N	-----			
	W				-----	EOT	-----			
	W				-----	GPL	-----			
	W				-----	DTL	-----			
Execution									Data transfer between the FDD and system.	
Result	R				-----	ST0	-----			Status information after Command execution. Sector ID information after Command execution.
	R				-----	ST1	-----			
	R				-----	ST2	-----			
	R				-----	C	-----			
	R				-----	H	-----			
	R				-----	R	-----			
	R				-----	N	-----			

WRITE DATA											
PHASE	R/W	DATA BUS								REMARKS	
		D7	D6	D5	D4	D3	D2	D1	D0		
Command	W	MT	MFM	0	0	0	1	0	1	Command Codes Sector ID information prior to Command execution.	
	W	0	0	0	0	0	HDS	DS1	DS0		
	W										----- C -----
	W										----- H -----
	W										----- R -----
	W										----- N -----
	W										----- EOT -----
	W										----- GPL -----
	W										----- DTL -----
Execution										Data transfer between the FDD and system.	
Result	R									Status information after Command execution. Sector ID information after Command execution.	
	R										----- ST0 -----
	R										----- ST1 -----
	R										----- ST2 -----
	R										----- C -----
	R										----- H -----
	R										----- R -----
R									----- N -----		

WRITE DELETED DATA											
PHASE	R/W	DATA BUS								REMARKS	
		D7	D6	D5	D4	D3	D2	D1	D0		
Command	W	MT	MFM	0	0	1	0	0	1	Command Codes Sector ID information prior to Command execution.	
	W	0	0	0	0	0	HDS	DS1	DS0		
	W										----- C -----
	W										----- H -----
	W										----- R -----
	W										----- N -----
	W										----- EOT -----
	W										----- GPL -----
	W										----- DTL -----
Execution										Data transfer between the FDD and system.	
Result	R									Status information after Command execution.	
	R									----- ST0 -----	
	R									----- ST1 -----	
	R									----- ST2 -----	
	R									----- C -----	
	R									----- H -----	
	R									----- R -----	
R									----- N -----		
										Sector ID information after Command execution.	

READ A TRACK											
PHASE	R/W	DATA BUS								REMARKS	
		D7	D6	D5	D4	D3	D2	D1	D0		
Command	W	0	MFM	0	0	0	0	1	0	Command Codes	
	W	0	0	0	0	0	HDS	DS1	DS0		
	W										Sector ID information prior to Command execution.
	W										
	W										
	W										
	W										
	W										
Execution										Data transfer between the FDD and system. FDC reads all of cylinders' contents from index hole to EOT.	
Result	R									Status information after Command execution.	
	R										
	R									Sector ID information after Command execution.	
	R										
	R										
	R										

VERIFY											
PHASE	R/W	DATA BUS								REMARKS	
		D7	D6	D5	D4	D3	D2	D1	D0		
Command	W	MT	MFM	SK	1	0	1	1	0	Command Codes	
	W	EC	0	0	0	0	HDS	DS1	DS0		
	W				-----	C	-----				Sector ID information prior to Command execution.
	W				-----	H	-----				
	W				-----	R	-----				
	W				-----	N	-----				
	W				-----	EOT	-----				
	W				-----	GPL	-----				
W				-----	DTL/SC	-----					
Execution										No data transfer takes place.	
Result	R				-----	ST0	-----			Status information after Command execution.	
	R				-----	ST1	-----				
	R				-----	ST2	-----				
	R				-----	C	-----			Sector ID information after Command execution.	
	R				-----	H	-----				
	R				-----	R	-----				
	R				-----	N	-----				

VERSION										
PHASE	R/W	DATA BUS								REMARKS
		D7	D6	D5	D4	D3	D2	D1	D0	
Command	W	0	0	0	1	0	0	0	0	Command Code
Result	R	1	0	0	1	0	0	0	0	Enhanced Controller

FORMAT A TRACK											
PHASE	R/W	DATA BUS								REMARKS	
		D7	D6	D5	D4	D3	D2	D1	D0		
Command	W	0	MFM	0	0	1	1	0	1	Command Codes	
	W	0	0	0	0	0	HDS	DS1	DS0		
	W										Bytes/Sector
	W										Sectors/Cylinder
	W										Gap 3
	W										Filler Byte
	W										Input Sector Parameters
Execution for Each Sector Repeat:	W										
	W										
	W										
	W										
Result	R									FDC formats an entire cylinder Status information after Command execution	
	R										
	R										
	R										
	R										
	R										
	R										

RECALIBRATE										
PHASE	R/W	DATA BUS								REMARKS
		D7	D6	D5	D4	D3	D2	D1	D0	
Command	W	0	0	0	0	0	1	1	1	Command Codes Head retracted to Track 0 Interrupt.
Execution	W	0	0	0	0	0	0	DS1	DS0	

SENSE INTERRUPT STATUS										
PHASE	R/W	DATA BUS								REMARKS
		D7	D6	D5	D4	D3	D2	D1	D0	
Command	W	0	0	0	0	1	0	0	0	Command Codes Status information at the end of each seek operation.
Result	R	----- ST0 -----								
	R	----- PCN -----								

SPECIFY										
PHASE	R/W	DATA BUS								REMARKS
		D7	D6	D5	D4	D3	D2	D1	D0	
Command	W	0	0	0	0	0	0	1	1	Command Codes
	W	--- SRT ---			--- HUT ---					
	W	----- HLT -----							ND	

SENSE DRIVE STATUS										
PHASE	R/W	DATA BUS								REMARKS
		D7	D6	D5	D4	D3	D2	D1	D0	
Command	W	0	0	0	0	0	1	0	0	Command Codes Status information about FDD
Result	W	0	0	0	0	0	HDS	DS1	DS0	
	R	----- ST3 -----								

SEEK										
PHASE	R/W	DATA BUS								REMARKS
		D7	D6	D5	D4	D3	D2	D1	D0	
Command	W	0	0	0	0	1	1	1	1	Command Codes Head positioned over proper cylinder on diskette.
Execution	W	0	0	0	0	0	HDS	DS1	DS0	
	W	----- NCN -----								

CONFIGURE										
PHASE	R/W	DATA BUS								REMARKS
		D7	D6	D5	D4	D3	D2	D1	D0	
Command	W	0	0	0	1	0	0	1	1	Configure Information
Execution	W	0	0	0	0	0	0	0	0	
	W	0	EIS	EFIFO	POLL		--- FIFOTHR ---			
	W	----- PRETRK -----								

RELATIVE SEEK										
PHASE	R/W	DATA BUS								REMARKS
		D7	D6	D5	D4	D3	D2	D1	D0	
Command	W	1	DIR	0	0	1	1	1	1	
	W	0	0	0	0	0	HDS	DS1	DS0	
	W	----- RCN -----								

DUMPREG											
PHASE	R/W	DATA BUS								REMARKS	
		D7	D6	D5	D4	D3	D2	D1	D0		
Command	W	0	0	0	0	1	1	1	0	*Note: Registers placed in FIFO	
Execution Result	R	----- PCN-Drive 0 -----									
	R	----- PCN-Drive 1 -----									
	R	----- PCN-Drive 2 -----									
	R	----- PCN-Drive 3 -----									
	R	---	SRT	---					---	HUT	---
	R	----- HLT -----									ND
	R	----- SC/EOT -----									
	R	LOCK	0	D3	D2	D1	D0	GAP	WGATE		
	R	0	EIS	EFIFO	POLL			--	FIFOTHR	--	
	R	----- PRETRK -----									

READ ID										
PHASE	R/W	DATA BUS								REMARKS
		D7	D6	D5	D4	D3	D2	D1	D0	
Command	W	0	MFM	0	0	1	0	1	0	Commands
Execution	W	0	0	0	0	0	HDS	DS1	DS0	
Result	R	----- ST0 -----								Status information after Command execution.
	R	----- ST1 -----								Disk status after the Command has completed
	R	----- ST2 -----								
	R	----- C -----								
	R	----- H -----								
	R	----- R -----								
	R	----- N -----								

PERPENDICULAR MODE										
PHASE	R/W	DATA BUS								REMARKS
		D7	D6	D5	D4	D3	D2	D1	D0	
Command	W	0	0	0	1	0	0	1	0	Command Codes
		OW	0	D3	D2	D1	D0	GAP	WGATE	

INVALID CODES										
PHASE	R/W	DATA BUS								REMARKS
		D7	D6	D5	D4	D3	D2	D1	D0	
Command	W	----- Invalid Codes -----								Invalid Command Codes (NoOp - FDC goes into Stand- by State) ST0 = 80H
Result	R	----- ST0 -----								

LOCK										
PHASE	R/W	DATA BUS								REMARKS
		D7	D6	D5	D4	D3	D2	D1	D0	
Command	W	LOCK	0	0	1	0	1	0	0	Command Codes
Result	R	0	0	0	LOCK	0	0	0	0	

SC is returned if the last command that was issued was the Format command. EOT is returned if the last command was a Read or Write.

Note: These bits are used internally only. They are not reflected in the Drive Select pins. It is the user's responsibility to maintain correspondence between these bits and the Drive Select pins (DOR).

DATA TRANSFER COMMANDS

All of the Read Data, Write Data and Verify type commands use the same parameter bytes and return the same results information, the only difference being the coding of bits 0-4 in the first byte.

An implied seek will be executed if the feature was enabled by the Configure command. This seek is completely transparent to the user. The Drive Busy bit for the drive will go active in the Main Status Register during the seek portion of the command. If the seek portion fails, it is reflected in the results status normally returned for a Read/Write Data command. Status Register 0 (ST0) would contain the error code and C would contain the cylinder on which the seek failed.

Read Data

A set of nine (9) bytes is required to place the FDC in the Read Data Mode. After the Read Data command has been issued, the FDC loads the head (if it is in the unloaded state), waits the specified head settling time (defined in the Specify command), and begins reading ID

Address Marks and ID fields. When the sector address read off the diskette matches with the sector address specified in the command, the FDC reads the sector's data field and transfers the data to the FIFO.

After completion of the read operation from the current sector, the sector address is incremented by one and the data from the next logical sector is read and output via the FIFO. This continuous read function is called "Multi-Sector Read Operation". Upon receipt of TC, or an implied TC (FIFO overrun/underrun), the FDC stops sending data but will continue to read data from the current sector, check the CRC bytes, and at the end of the sector, terminate the Read Data Command. N determines the number of bytes per sector (see Table 23 below). If N is set to zero, the sector size is set to 128. The DTL value determines the number of bytes to be transferred. If DTL is less than 128, the FDC transfers the specified number of bytes to the host. For reads, it continues to read the entire 128-byte sector and checks for CRC errors. For writes, it completes the 128-byte sector by filling in zeros. If N is not set to 00 Hex, DTL should be set to FF Hex and has no impact on the number of bytes transferred.

TABLE 23 - SECTOR SIZES

N	SECTOR SIZE
00	128 bytes
01	256 bytes
02	512 bytes
03	1024 bytes
..	...
07	16 Kbytes

The amount of data which can be handled with a single command to the FDC depends upon MT (multi-track) and N (number of bytes/sector).

The Multi-Track function (MT) allows the FDC to read data from both sides of the diskette. For a particular cylinder, data will be transferred starting at Sector 1, Side 0 and completing the last sector of the same track at Side 1.

If the host terminates a read or write operation in the FDC, the ID information in the result phase is dependent upon the state of the MT bit and EOT byte. Refer to Table 24.

At the completion of the Read Data command, the head is not unloaded until after the Head Unload Time Interval (specified in the Specify command) has elapsed. If the host issues another command before the head unloads, then the head settling time may be saved between subsequent reads.

If the FDC detects a pulse on the nINDEX pin twice without finding the specified sector (meaning that the diskette's index hole passes through index detect logic in the drive twice), the FDC sets the IC code in Status Register 0 to "01" indicating abnormal termination, sets the ND bit in Status Register 1 to "1" indicating a sector not found, and terminates the Read Data Command.

After reading the ID and Data Fields in each sector, the FDC checks the CRC bytes. If a CRC error occurs in the ID or data field, the FDC sets the IC code in Status Register 0 to "01" indicating abnormal termination, sets the DE bit flag in Status Register 1 to "1", sets the DD bit in Status Register 2 to "1" if CRC is incorrect in the ID field, and terminates the Read Data Command. Table 25 describes the effect of the SK bit on the Read Data command execution and results. Except where noted in Table 25, the C or R value of the sector address is automatically incremented.

TABLE 24 - EFFECTS OF MT AND N BITS

MT	N	MAXIMUM TRANSFER CAPACITY	FINAL SECTOR READ FROM DISK
0	1	256 x 26 = 6,656	26 at side 0 or 1
1	1	256 x 52 = 13,312	26 at side 1
0	2	512 x 15 = 7,680	15 at side 0 or 1
1	2	512 x 30 = 15,360	15 at side 1
0	3	1024 x 8 = 8,192	8 at side 0 or 1
1	3	1024 x 16 = 16,384	16 at side 1

TABLE 25 - SKIP BIT VS READ DATA COMMAND

SK BIT VALUE	DATA ADDRESS MARK TYPE ENCOUNTERED	RESULTS		
		SECTOR READ?	CM BIT OF ST2 SET?	DESCRIPTION OF RESULTS
0	Normal Data	Yes	No	Normal termination.
0	Deleted Data	Yes	Yes	Address not incremented. Next sector not searched for.
1	Normal Data	Yes	No	Normal termination.
1	Deleted Data	No	Yes	Normal termination. Sector not read ("skipped").

Read Deleted Data

This command is the same as the Read Data command, only it operates on sectors that contain a Deleted Data Address Mark at the beginning of a Data Field.

TABLE 26 describes the effect of the SK bit on the Read Deleted Data command execution and results.

Except where noted in Table 26, the C or R value of the sector address is automatically incremented (see Table 27).

TABLE 26 - SKIP BIT VS. READ DELETED DATA COMMAND

SK BIT VALUE	DATA ADDRESS MARK TYPE ENCOUNTERED	RESULTS		
		SECTOR READ?	CM BIT OF ST2 SET?	DESCRIPTION OF RESULTS
0	Normal Data	Yes	Yes	Address not incremented. Next sector not searched for.
0	Deleted Data	Yes	No	Normal termination.
1	Normal Data	No	Yes	Normal termination. Sector not read ("skipped").
1	Deleted Data	Yes	No	Normal termination.

Read A Track

This command is similar to the Read Data command except that the entire data field is read continuously from each of the sectors of a track. Immediately after encountering a pulse on the nINDEX pin, the FDC starts to read all data fields on the track as continuous blocks of data without regard to logical sector numbers. If the FDC finds an error in the ID or DATA CRC check bytes, it continues to read data from the track and sets the appropriate error bits at the end of the command. The FDC compares the ID information read from each sector with the specified value in the command and sets the ND flag of Status Register

1 to a "1" if there is no comparison. Multi-track or skip operations are not allowed with this command. The MT and SK bits (bits D7 and D5 of the first command byte respectively) should always be set to "0".

This command terminates when the EOT specified number of sectors has not been read. If the FDC does not find an ID Address Mark on the diskette after the second occurrence of a pulse on the IDX pin, then it sets the IC code in Status Register 0 to "01" (abnormal termination), sets the MA bit in Status Register 1 to "1", and terminates the command.

TABLE 27 - RESULT PHASE TABLE

MT	HEAD	FINAL SECTOR TRANSFERRED TO HOST	ID INFORMATION AT RESULT PHASE			
			C	H	R	N
0	0	Less than EOT	NC	NC	R + 1	NC
		Equal to EOT	C + 1	NC	01	NC
	1	Less than EOT	NC	NC	R + 1	NC
		Equal to EOT	C + 1	NC	01	NC
1	0	Less than EOT	NC	NC	R + 1	NC
		Equal to EOT	NC	LSB	01	NC
	1	Less than EOT	NC	NC	R + 1	NC
		Equal to EOT	C + 1	LSB	01	NC

NC: No Change, the same value as the one at the beginning of command execution.
 LSB: Least Significant Bit, the LSB of H is complemented.

Write Data

After the Write Data command has been issued, the FDC loads the head (if it is in the unloaded state), waits the specified head load time if unloaded (defined in the Specify command), and begins reading ID fields. When the sector address read from the diskette matches the sector address specified in the command, the FDC reads the data from the host via the FIFO and writes it to the sector's data field.

After writing data into the current sector, the FDC computes the CRC value and writes it into the CRC field at the end of the sector transfer. The Sector Number stored in "R" is incremented by one, and the FDC continues writing to the next data field. The FDC continues this "Multi-Sector Write Operation". Upon receipt of a terminal count signal or if a FIFO over/under run occurs while a data field is being written, then the remainder of the data field is filled with zeros. The FDC reads the ID field of each sector and checks the CRC bytes. If it detects a CRC error in one of the ID fields, it sets the IC code in Status Register 0 to "01" (abnormal termination), sets the DE bit of Status Register 1 to "1", and terminates the Write Data command.

The Write Data command operates in much the same manner as the Read Data command. The following items are the same. Please refer to the Read Data Command for details:

- Transfer Capacity
- EN (End of Cylinder) bit
- ND (No Data) bit
- Head Load, Unload Time Interval
- ID information when the host terminates the command
- Definition of DTL when N = 0 and when N does not = 0

Write Deleted Data

This command is almost the same as the Write Data command except that a Deleted Data Address Mark is written at the beginning of the Data Field instead of the normal Data Address Mark. This command is typically used to mark a bad sector containing an error on the floppy disk.

Verify

The Verify command is used to verify the data stored on a disk. This command acts exactly like a Read Data command except that no data is transferred to the host. Data is read from the disk and CRC is computed and checked against the previously-stored value.

Because data is not transferred to the host, TC (pin 89) cannot be used to terminate this command. By setting the EC bit to "1", an implicit TC will be issued to the FDC. This implicit TC will occur when the SC value has decremented to 0 (an SC value of 0 will verify 256 sectors). This

command can also be terminated by setting the EC bit to "0" and the EOT value equal to the final sector to be checked. If EC is set to "0", DTL/SC should be programmed to 0FFH. Refer to Table 27 and Table 28 for information concerning the values of MT and EC versus SC and EOT value.

Definitions:

Sectors Per Side = Number of formatted sectors per each side of the disk.

Sectors Remaining = Number of formatted sectors left which can be read, including side 1 of the disk if MT is set to "1".

TABLE 28 - VERIFY COMMAND RESULT PHASE

MT	EC	SC/EOT VALUE	TERMINATION RESULT
0	0	SC = DTL EOT ≤ # Sectors Per Side	Success Termination Result Phase Valid
0	0	SC = DTL EOT > # Sectors Per Side	Unsuccessful Termination Result Phase Invalid
0	1	SC ≤ # Sectors Remaining AND EOT ≤ # Sectors Per Side	Successful Termination Result Phase Valid
0	1	SC > # Sectors Remaining OR EOT > # Sectors Per Side	Unsuccessful Termination Result Phase Invalid
1	0	SC = DTL EOT ≤ # Sectors Per Side	Successful Termination Result Phase Valid
1	0	SC = DTL EOT > # Sectors Per Side	Unsuccessful Termination Result Phase Invalid
1	1	SC ≤ # Sectors Remaining AND EOT ≤ # Sectors Per Side	Successful Termination Result Phase Valid
1	1	SC > # Sectors Remaining OR EOT > # Sectors Per Side	Unsuccessful Termination Result Phase Invalid

Note: If MT is set to "1" and the SC value is greater than the number of remaining formatted sectors on Side 0, verifying will continue on Side 1 of the disk.

Format A Track

The Format command allows an entire track to be formatted. After a pulse from the IDX pin is detected, the FDC starts writing data on the disk including gaps, address marks, ID fields, and data fields per the IBM System 34 or 3740 format (MFM or FM respectively). The particular values that will be written to the gap and data field are controlled by the values programmed into N, SC, GPL, and D which are specified by the host during the command phase. The data field of the sector is filled with the data byte specified by D. The ID field for each sector is supplied by the host; that is, four data bytes per sector are needed by the FDC for

C, H, R, and N (cylinder, head, sector number and sector size respectively).

After formatting each sector, the host must send new values for C, H, R and N to the FDC for the next sector on the track. The R value (sector number) is the only value that must be changed by the host after each sector is formatted. This allows the disk to be formatted with nonsequential sector addresses (interleaving). This incrementing and formatting continues for the whole track until the FDC encounters a pulse on the IDX pin again and it terminates the command.

TABLE 29 contains typical values for gap fields which are dependent upon the size of the sector and the number of sectors on each track. Actual values can vary due to drive electronics.

FORMAT FIELDS

SYSTEM 34 (DOUBLE DENSITY) FORMAT

GAP4a 80x 4E	SYNC 12x 00	IAM		GAP1 50x 4E	SYNC 12x 00	IDAM		C Y L	H D	S E C	N O	C R C	GAP2 22x 4E	SYNC 12x 00	DATA AM		DATA	C R C	GAP3	GAP 4b
		3x C2	FC			3x A1	FE								3x A1	FB F8				

SYSTEM 3740 (SINGLE DENSITY) FORMAT

GAP4a 40x FF	SYNC 6x 00	IAM		GAP1 26x FF	SYNC 6x 00	IDAM		C Y L	H D	S E C	N O	C R C	GAP2 11x FF	SYNC 6x 00	DATA AM		DATA	C R C	GAP3	GAP 4b
		FC				FE									FB or F8					

PERPENDICULAR FORMAT

GAP4a 80x 4E	SYNC 12x 00	IAM		GAP1 50x 4E	SYNC 12x 00	IDAM		C Y L	H D	S E C	N O	C R C	GAP2 41x 4E	SYNC 12x 00	DATA AM		DATA	C R C	GAP3	GAP 4b
		3x C2	FC			3x A1	FE								3x A1	FB F8				

TABLE 29 - TYPICAL VALUES FOR FORMATTING

	FORMAT	SECTOR SIZE	N	SC	GPL1	GPL2
5.25" Drives	FM	128	00	12	07	09
		128	00	10	10	19
		512	02	08	18	30
		1024	03	04	46	87
		2048	04	02	C8	FF
		4096	05	01	C8	FF
				
	MFM	256	01	12	0A	0C
		256	01	10	20	32
		512*	02	09	2A	50
		1024	03	04	80	F0
		2048	04	02	C8	FF
		4096	05	01	C8	FF
				
3.5" Drives	FM	128	0	0F	07	1B
		256	1	09	0F	2A
		512	2	05	1B	3A
	MFM	256	1	0F	0E	36
		512**	2	09	1B	54
		1024	3	05	35	74

GPL1 = suggested GPL values in Read and Write commands to avoid splice point between data field and ID field of contiguous sections.

GPL2 = suggested GPL value in Format A Track command.

*PC/AT values (typical)

**PS/2 values (typical). Applies with 1.0 MB and 2.0 MB drives.

NOTE: All values except sector size are in hex.

CONTROL COMMANDS

Control commands differ from the other commands in that no data transfer takes place. Three commands generate an interrupt when complete: Read ID, Recalibrate, and Seek. The other control commands do not generate an interrupt.

Read ID

The Read ID command is used to find the present position of the recording heads. The FDC stores the values from the first ID field it is able to read into its registers. If the FDC does not find an ID address mark on the diskette after the second occurrence of a pulse on the nINDEX pin, it then sets the IC code in Status Register 0 to "01" (abnormal termination), sets the MA bit in Status Register 1 to "1", and terminates the command.

The following commands will generate an interrupt upon completion. They do not return any result bytes. It is highly recommended that control commands be followed by the Sense Interrupt Status command. Otherwise, valuable interrupt status information will be lost.

Recalibrate

This command causes the read/write head within the FDC to retract to the track 0 position. The FDC clears the contents of the PCN counter and checks the status of the nTR0 pin from the FDD. As long as the nTR0 pin is low, the DIR pin remains 0 and step pulses are issued. When the nTR0 pin goes high, the SE bit in Status Register 0 is set to "1" and the command is terminated. If the nTR0 pin is still low after 79 step pulses have been issued, the FDC sets the SE and the EC bits of Status Register 0 to "1" and terminates the command. Disks capable of handling more than 80 tracks per side may require more than one Recalibrate command to return the head back to physical Track 0.

The Recalibrate command does not have a result phase. The Sense Interrupt Status command must be issued after the Recalibrate command to effectively terminate it and to provide verification of the head position (PCN). During the command

phase of the recalibrate operation, the FDC is in the BUSY state, but during the execution phase it is in a NON-BUSY state. At this time, another Recalibrate command may be issued, and in this manner parallel Recalibrate operations may be done on up to four drives at once.

Upon power up, the software must issue a Recalibrate command to properly initialize all drives and the controller.

Seek

The read/write head within the drive is moved from track to track under the control of the Seek command. The FDC compares the PCN, which is the current head position, with the NCN and performs the following operation if there is a difference:

PCN < NCN: Direction signal to drive set to "1" (step in) and issues step pulses.

PCN > NCN: Direction signal to drive set to "0" (step out) and issues step pulses.

The rate at which step pulses are issued is controlled by SRT (Stepping Rate Time) in the Specify command. After each step pulse is issued, NCN is compared against PCN, and when NCN = PCN the SE bit in Status Register 0 is set to "1" and the command is terminated. During the command phase of the seek or recalibrate operation, the FDC is in the BUSY state, but during the execution phase it is in the NON-BUSY state. At this time, another Seek or Recalibrate command may be issued, and in this manner, parallel seek operations may be done on up to four drives at once.

Note that if implied seek is not enabled, the read and write commands should be preceded by:

- 1) Seek command - Step to the proper track
- 2) Sense Interrupt Status command - Terminate the Seek command
- 3) Read ID - Verify head is on proper track
- 4) Issue Read/Write command.

The Seek command does not have a result phase. Therefore, it is highly recommended that the

Sense Interrupt Status command is issued after the Seek command to terminate it and to provide verification of the head position (PCN). The H bit (Head Address) in ST0 will always return to a "0". When exiting POWERDOWN mode, the FDC clears the PCN value and the status information to zero. Prior to issuing the POWERDOWN command, it is highly recommended that the user service all pending interrupts through the Sense Interrupt Status command.

Sense Interrupt Status

An interrupt signal on FINT pin is generated by the FDC for one of the following reasons:

1. Upon entering the Result Phase of:
 - a. Read Data command
 - b. Read A Track command
 - c. Read ID command
 - d. Read Deleted Data command
 - e. Write Data command
 - f. Format A Track command
 - g. Write Deleted Data command
 - h. Verify command
2. End of Seek, Relative Seek, or Recalibrate command
3. FDC requires a data transfer during the execution phase in the non-DMA mode

The Sense Interrupt Status command resets the interrupt signal and, via the IC code and SE bit of Status Register 0, identifies the cause of the interrupt.

TABLE 30 - INTERRUPT IDENTIFICATION

SE	IC	INTERRUPT DUE TO
0	11	Polling
1	00	Normal termination of Seek or Recalibrate command
1	01	Abnormal termination of Seek or Recalibrate command

The Seek, Relative Seek, and Recalibrate commands have no result phase. The Sense Interrupt Status command must be issued immediately after these commands to terminate them and to provide verification of the head position (PCN). The H (Head Address) bit in ST0 will always return a "0". If a Sense Interrupt Status is not issued, the drive will continue to be BUSY and may affect the operation of the next command.

Sense Drive Status

Sense Drive Status obtains drive status information. It has no execution phase and goes directly to the result phase from the command phase. Status Register 3 contains the drive status information.

Specify

The Specify command sets the initial values for each of the three internal times. The HUT (Head Unload Time) defines the time from the end of the execution phase of one of the read/write commands to the head unload state. The SRT (Step Rate Time) defines the time interval between adjacent step pulses. Note that the spacing between the first and second step pulses may be shorter than the remaining step pulses. The HLT (Head Load Time) defines the time between when the Head Load signal goes high and the read/write operation starts. The values change with the data rate speed selection and are documented in TABLE 31. The values are the same for MFM and FM.

TABLE 31 - DRIVE CONTROL DELAYS (MS)

	HUT					SRT				
	2M	1M	500K	300K	250K	2M	1M	500K	300K	250K
0	64	128	256	426	512	4	8	16	26.7	32
1	4	8	16	26.7	32	3.75	7.5	15	25	30

..
E	56	112	224	373	448	0.5	1	2	3.33	4
F	60	120	240	400	480	0.25	0.5	1	1.67	2

HLT					
	2M	1M	500K	300K	250K
00	64	128	256	426	512
01	0.5	1	2	3.3	4
02	1	2	4	6.7	8
..
7F	63	126	252	420	504
7F	63.5	127	254	423	508

The choice of DMA or non-DMA operations is made by the ND bit. When this bit is "1", the non-DMA mode is selected, and when ND is "0", the DMA mode is selected. In DMA mode, data transfers are signaled by the FDRQ pin. Non-DMA mode uses the RQM bit and the FINT pin to signal data transfers.

Configure

The Configure command is issued to select the special features of the FDC. A Configure command need not be issued if the default values of the FDC meet the system requirements.

Configure Default Values:

- EIS - No Implied Seeks
- EFIFO - FIFO Disabled
- POLL - Polling Enabled
- FIFOTHR - FIFO Threshold Set to 1 Byte
- PRETRK - Pre-Compensation Set to Track 0

EIS - Enable Implied Seek. When set to "1", the FDC will perform a Seek operation before executing a read or write command. Defaults to no implied seek.

EFIFO - A "1" disables the FIFO (default). This means data transfers are asked for on a byte-by-byte basis. Defaults to "1", FIFO disabled. The threshold defaults to "1".

POLL - Disable polling of the drives. Defaults to "0", polling enabled. When enabled, a single interrupt is generated after a reset. No polling is

performed while the drive head is loaded and the head unload delay has not expired.

FIFOTHR - The FIFO threshold in the execution phase of read or write commands. This is programmable from 1 to 16 bytes. Defaults to one byte. A "00" selects one byte; "0F" selects 16 bytes.

PRETRK - Pre-Compensation Start Track Number. Programmable from track 0 to 255. Defaults to track 0. A "00" selects track 0; "FF" selects track 255.

Version

The Version command checks to see if the controller is an enhanced type or the older type (765A). A value of 90 H is returned as the result byte.

Relative Seek

The command is coded the same as for Seek, except for the MSB of the first byte and the DIR bit.

DIR	ACTION
0	Step Head Out
1	Step Head In

DIR Head Step Direction Control

RCN Relative Cylinder Number that determines how many tracks to step the head in or out from the current track number.

The Relative Seek command differs from the Seek command in that it steps the head the absolute number of tracks specified in the command instead of making a comparison against an internal register. The Seek command is good for drives that support a maximum of 256 tracks. Relative Seeks cannot be overlapped with other Relative Seeks. Only one Relative Seek can be active at a time. Relative Seeks may be overlapped with Seeks and Recalibrates. Bit 4 of Status Register 0 (EC) will be set if Relative Seek attempts to step outward beyond Track 0.

As an example, assume that a floppy drive has 300 useable tracks. The host needs to read track 300 and the head is on any track (0-255). If a Seek command is issued, the head will stop at track 255. If a Relative Seek command is issued, the FDC will move the head the specified number of tracks, regardless of the internal cylinder position register (but will increment the register). If the head was on track 40 (d), the maximum track that the FDC could position the head on using Relative Seek will be 295 (D), the initial track + 255 (D). The maximum count that the head can be moved with a single Relative Seek command is 255 (D).

The internal register, PCN, will overflow as the cylinder number crosses track 255 and will contain 39 (D). The resulting PCN value is thus $(RCN + PCN) \text{ mod } 256$. Functionally, the FDC starts counting from 0 again as the track number goes above 255 (D). It is the user's responsibility to compensate FDC functions (precompensation track number) when accessing tracks greater than 255. The FDC does not keep track that it is working in an "extended track area" (greater than 255). Any command issued will use the current PCN value except for the Recalibrate command, which only looks for the TRACK0 signal. Recalibrate will return an error if the head is farther than 79 due to its limitation of issuing a maximum of 80 step pulses. The user simply needs to issue a second Recalibrate command. The Seek command and implied seeks will function correctly within the 44 (D) track (299-255) area of the "extended track area". It is the user's responsibility not to issue a new track position that will exceed the maximum track that is present in the extended area.

To return to the standard floppy range (0-255) of tracks, a Relative Seek should be issued to cross the track 255 boundary.

A Relative Seek can be used instead of the normal Seek, but the host is required to calculate the difference between the current head location and the new (target) head location. This may require the host to issue a Read ID command to ensure that the head is physically on the track that software assumes it to be. Different FDC commands will return different cylinder results which may be difficult to keep track of with software without the Read ID command.

Perpendicular Mode

The Perpendicular Mode command should be issued prior to executing Read/Write/Format commands that access a disk drive with perpendicular recording capability. With this command, the length of the Gap2 field and VCO enable timing can be altered to accommodate the unique requirements of these drives. TABLE 32 describes the effects of the WGATE and GAP bits for the Perpendicular Mode command. Upon a

reset, the FDC will default to the conventional mode (WGATE = 0, GAP = 0).

Selection of the 500 Kbps and 1 Mbps perpendicular modes is independent of the actual data rate selected in the Data Rate Select Register. The user must ensure that these two data rates remain consistent.

The Gap2 and VCO timing requirements for perpendicular recording type drives are dictated by the design of the read/write head. In the design of this head, a pre-erase head precedes the normal read/write head by a distance of 200 micrometers. This works out to about 38 bytes at a 1 Mbps recording density. Whenever the write head is enabled by the Write Gate signal, the pre-erase head is also activated at the same time. Thus, when the write head is initially turned on, flux transitions recorded on the media for the first 38 bytes will not be preconditioned with the pre-erase head since it has not yet been activated. To accommodate this head activation and deactivation time, the Gap2 field is expanded to a length of 41 bytes. The format field shown on Page 58 illustrates the change in the Gap2 field size for the perpendicular format.

On the read back by the FDC, the controller must begin synchronization at the beginning of the sync field. For the conventional mode, the internal PLL VCO is enabled (VCOEN) approximately 24 bytes from the start of the Gap2 field. But, when the controller operates in the 1 Mbps perpendicular mode (WGATE = 1, GAP = 1), VCOEN goes active after 43 bytes to accommodate the increased Gap2 field size. For both cases, an approximate two-byte cushion is maintained from the beginning of the sync field for the purposes of avoiding write splices in the presence of motor speed variation.

For the Write Data case, the FDC activates Write Gate at the beginning of the sync field under the conventional mode. The controller then writes a new sync field, data address mark, data field, and CRC as shown on page 57. With the pre-erase head of the perpendicular drive, the write head must be activated in the Gap2 field to insure a proper write of the new sync field. For the 1 Mbps

perpendicular mode (WGATE = 1, GAP = 1), 38 bytes will be written in the Gap2 space. Since the bit density is proportional to the data rate, 19 bytes will be written in the Gap2 field for the 500 Kbps perpendicular mode (WGATE = 1, GAP = 0).

It should be noted that none of the alterations in Gap2 size, VCO timing, or Write Gate timing affect normal program flow. The information provided here is just for background purposes and is not needed for normal operation. Once the Perpendicular Mode command is invoked, FDC software behavior from the user standpoint is unchanged.

The perpendicular mode command is enhanced to allow specific drives to be designated Perpendicular recording drives. This enhancement allows data transfers between Conventional and Perpendicular drives without having to issue Perpendicular mode commands between the accesses of the different drive types, nor having to change write pre-compensation values.

When both GAP and WGATE bits of the PERPENDICULAR MODE COMMAND are both programmed to "0" (Conventional mode), then D0, D1, D2, D3, and D4 can be programmed independently to "1" for that drive to be set automatically to Perpendicular mode. In this mode the following set of conditions also apply:

1. The GAP2 written to a perpendicular drive during a write operation will depend upon the programmed data rate.
2. The write pre-compensation given to a perpendicular mode drive will be 0ns.
3. For D0-D3 programmed to "0" for conventional mode drives any data written will be at the currently programmed write pre-compensation.

Note: Bits D0-D3 can only be overwritten when OW is programmed as a "1". If either GAP or WGATE is a "1" then D0-D3 are ignored.

Software and hardware resets have the following effect on the PERPENDICULAR MODE COMMAND:

1. "Software" resets (via the DOR or DSR registers) will only clear GAP and WGATE bits

to "0". D0-D3 are unaffected and retain their previous value.

(GAP, WGATE and D0-D3) to "0", i.e all conventional mode.

- "Hardware" resets will clear all bits

TABLE 32 - EFFECTS OF WGATE AND GAP BITS

WGATE	GAP	MODE	LENGTH OF GAP2 FORMAT FIELD	PORTION OF GAP 2 WRITTEN BY WRITE DATA OPERATION
0	0	Conventional	22 Bytes	0 Bytes
0	1	Perpendicular (500 Kbps)	22 Bytes	19 Bytes
1	0	Reserved (Conventional)	22 Bytes	0 Bytes
1	1	Perpendicular (1 Mbps)	41 Bytes	38 Bytes

LOCK

In order to protect systems with long DMA latencies against older application software that can disable the FIFO the LOCK Command has been added. This command should only be used by the FDC routines, and application software should refrain from using it. If an application calls for the FIFO to be disabled then the CONFIGURE command should be used.

The LOCK command defines whether the EFIFO, FIFOTHR, and PRETRK parameters of the CONFIGURE command can be RESET by the DOR and DSR registers. When the LOCK bit is set to logic "1" all subsequent "software RESETS" by the DOR and DSR registers will not change the previously set parameters to their default values. All "hardware" RESET from the RESET pin will set the LOCK bit to logic "0" and return the EFIFO, FIFOTHR, and PRETRK to their default values. A status byte is returned immediately after issuing a LOCK command. This byte reflects the value of the LOCK bit set by the command byte.

ENHANCED DUMPREG

The DUMPREG command is designed to support system run-time diagnostics and application software development and debug. To accommodate the LOCK command and the enhanced PERPENDICULAR MODE command

the eighth byte of the DUMPREG command has been modified to contain the additional data from these two commands.

COMPATIBILITY

This chip was designed with software compatibility in mind. It is a fully backwards-compatible solution with the older generation 765A/B disk controllers. The FDC also implements on-board registers for compatibility with the PS/2, as well as PC/AT and PC/XT, floppy disk controller subsystems. After a hardware reset of the FDC, all registers, functions and enhancements default to a PC/AT, PS/2 or PS/2 Model 30 compatible operating mode, depending on how the IDENT and MFM bits are configured by the system BIOS.

Force Write Protect

The *Force Write Protect* function forces the FDD nWRTPRT input active if the FORCE WRTPRT bit is active. The *Force Write Protect* function applies to the nWRTPRT pin in the FDD Interface as well as the nWRTPRT pin in the Parallel Port FDC. Refer to Configuration Register L8CR_C5 for more information.

SERIAL PORT (UART)

The chip incorporates two full function UARTs. They are compatible with the NS16450, the 16450 ACE registers and the NS16C550A. The UARTS perform serial-to-parallel conversion on received characters and parallel-to-serial conversion on transmit characters. The data rates are independently programmable from 460.8K baud down to 50 baud. The character options are programmable for 1 start; 1, 1.5 or 2 stop bits; even, odd, sticky or no parity; and prioritized interrupts. The UARTs each contain a programmable baud rate generator that is capable of dividing the input clock or crystal by a number from 1 to 65535. The UARTs are also capable of supporting the MIDI data rate. Refer to the Configuration Registers for information on

disabling, power down and changing the base address of the UARTs. The interrupt from a UART is enabled by programming OUT2 of that UART to a logic "1". OUT2 being a logic "0" disables that UART's interrupt. The second UART also supports IrDA 1.0, HP-SIR, ASK-IR and Consumer IR infrared modes of operation.

Note: The UARTs may be configured to share an interrupt. Refer to the Configuration section for more information.

REGISTER DESCRIPTION

Addressing of the accessible registers of the Serial Port is shown below. The configuration registers

(see Configuration section) define the base addresses of the serial ports. The Serial Port registers are located at sequentially increasing addresses above these base addresses. The chip

contains two serial ports, each of which contain a register set as described below.

TABLE 33 - ADDRESSING THE SERIAL PORT

DLAB*	A2	A1	A0	REGISTER NAME
0	0	0	0	Receive Buffer (read)
0	0	0	0	Transmit Buffer (write)
0	0	0	1	Interrupt Enable (read/write)
X	0	1	0	Interrupt Identification (read)
X	0	1	0	FIFO Control (write)
X	0	1	1	Line Control (read/write)
X	1	0	0	Modem Control (read/write)
X	1	0	1	Line Status (read/write)
X	1	1	0	Modem Status (read/write)
X	1	1	1	Scratchpad (read/write)
1	0	0	0	Divisor LSB (read/write)
1	0	0	1	Divisor MSB (read/write)

*Note: DLAB is Bit 7 of the Line Control Register

The following section describes the operation of the registers.

RECEIVE BUFFER REGISTER (RB)

Address Offset = 0H, DLAB = 0, READ ONLY

This register holds the received incoming data byte. Bit 0 is the least significant bit, which is transmitted and received first. Received data is double buffered; this uses an additional shift register to receive the serial data stream and convert it to a parallel 8 bit word which is transferred to the Receive Buffer register. The shift register is not accessible.

TRANSMIT BUFFER REGISTER (TB)

Address Offset = 0H, DLAB = 0, WRITE ONLY

This register contains the data byte to be transmitted. The transmit buffer is double buffered, utilizing an additional shift register (not accessible) to convert the 8 bit data word to a serial format. This shift register is loaded from the Transmit Buffer when the transmission of the previous byte is complete.

INTERRUPT ENABLE REGISTER (IER)

Address Offset = 1H, DLAB = 0, READ/WRITE

The lower four bits of this register control the enables of the five interrupt sources of the Serial Port interrupt. It is possible to totally disable the interrupt system by resetting bits 0 through 3 of this register. Similarly, setting the appropriate bits of this register to a high, selected interrupts can be enabled. Disabling the interrupt system inhibits the Interrupt Identification Register and disables any Serial Port interrupt out of the chip. All other system functions operate in their normal manner, including the Line Status and MODEM Status Registers. The contents of the Interrupt Enable Register are described below.

Bit 0

This bit enables the Received Data Available Interrupt (and timeout interrupts in the FIFO mode) when set to logic "1".

Bit 1

This bit enables the Transmitter Holding Register Empty Interrupt when set to logic "1".

Bit 2

This bit enables the Received Line Status Interrupt when set to logic "1". The error sources causing the interrupt are Overrun, Parity, Framing and Break. The Line Status Register must be read to determine the source.

Bit 3

This bit enables the MODEM Status Interrupt when set to logic "1". This is caused when one of the Modem Status Register bits changes state.

Bits 4 through 7

These bits are always logic "0".

FIFO CONTROL REGISTER (FCR)

Address Offset = 2H, DLAB = X, WRITE

This is a write only register at the same location as the IIR. This register is used to enable and clear the FIFOs, set the RCVR FIFO trigger level. Note: DMA is not supported. The UART1 and UART2 FCR's are shadowed in the UART1 FIFO Control Shadow Register (LD8:CRC3[7:0]) and UART2 FIFO Control Shadow Register (LD8:CRC4[7:0]).

Bit 0

Setting this bit to a logic "1" enables both the XMIT and RCVR FIFOs. Clearing this bit to a logic "0" disables both the XMIT and RCVR FIFOs and clears all bytes from both FIFOs. When changing from FIFO Mode to non-FIFO (16450) mode, data is automatically cleared from the FIFOs. This bit must be a 1 when other bits in this register are written to or they will not be properly programmed.

Bit 1

Setting this bit to a logic "1" clears all bytes in the RCVR FIFO and resets its counter logic to 0. The shift register is not cleared. This bit is self-clearing.

Bit 2

Setting this bit to a logic "1" clears all bytes in the XMIT FIFO and resets its counter logic to 0. The shift register is not cleared. This bit is self-clearing.

Bit 3

Writing to this bit has no effect on the operation of the UART. The RXRDY and TXRDY pins are not available on this chip.

Bit 4,5

Reserved

Bit 6,7

These bits are used to set the trigger level for the RCVR FIFO interrupt.

Bit 7	Bit 6	RCVR FIFO Trigger Level (BYTES)
0	0	1
0	1	4
1	0	8
1	1	14

INTERRUPT IDENTIFICATION REGISTER (IIR)

Address Offset = 2H, DLAB = X, READ

By accessing this register, the host CPU can determine the highest priority interrupt and its source. Four levels of priority interrupt exist. They are in descending order of priority:

1. Receiver Line Status (highest priority)
2. Received Data Ready

3. Transmitter Holding Register Empty
4. MODEM Status (lowest priority)

Information indicating that a prioritized interrupt is pending and the source of that interrupt is stored in the Interrupt Identification Register (refer to Interrupt Control Table). When the CPU accesses the IIR, the Serial Port freezes all interrupts and indicates the highest priority pending interrupt to the CPU. During this CPU access, even if the Serial Port records new interrupts, the current indication does not change until access is completed. The contents of the IIR are described below.

Bit 0

This bit can be used in either a hardwired prioritized or polled environment to indicate whether an interrupt is pending. When bit 0 is a logic "0", an interrupt is pending and the contents of the IIR may be used as a pointer to the appropriate internal service routine. When bit 0 is a logic "1", no interrupt is pending.

Bits 1 and 2

These two bits of the IIR are used to identify the highest priority interrupt pending as indicated by the Interrupt Control Table.

Bit 3

In non-FIFO mode, this bit is a logic "0". In FIFO mode this bit is set along with bit 2 when a timeout interrupt is pending.

Bits 4 and 5

These bits of the IIR are always logic "0".

Bits 6 and 7

These two bits are set when the FIFO CONTROL Register bit 0 equals 1.

TABLE 34 - INTERRUPT CONTROL

FIFO MODE ONLY	INTERRUPT IDENTIFICATION REGISTER			INTERRUPT SET AND RESET FUNCTIONS			
	BIT 3	BIT 2	BIT 1	BIT 0	PRIORITY LEVEL	INTERRUPT TYPE	INTERRUPT SOURCE
0	0	0	1	-	None	None	-
0	1	1	0	Highest	Receiver Line Status	Overrun Error, Parity Error, Framing Error or Break Interrupt	Reading the Line Status Register
0	1	0	0	Second	Received Data Available	Receiver Data Available	Read Receiver Buffer or the FIFO drops below the trigger level.
1	1	0	0	Second	Character Timeout Indication	No Characters Have Been Removed From or Input to the RCVR FIFO during the last 4 Char times and there is at least 1 char in it during this time	Reading the Receiver Buffer Register
0	0	1	0	Third	Transmitter Holding Register Empty	Transmitter Holding Register Empty	Reading the IIR Register (if Source of Interrupt) or Writing the Transmitter Holding Register
0	0	0	0	Fourth	MODEM Status	Clear to Send or Data Set Ready or Ring Indicator or Data Carrier Detect	Reading the MODEM Status Register

LINE CONTROL REGISTER (LCR)

Address Offset = 3H, DLAB = 0, READ/WRITE

This register contains the format information of the serial line. The bit definitions are:

Bits 0 and 1

These two bits specify the number of bits in each transmitted or received serial character. The encoding of bits 0 and 1 is as follows:

The Start, Stop and Parity bits are not included in the word length.

BIT 1	BIT 0	WORD LENGTH
0	0	5 Bits
0	1	6 Bits
1	0	7 Bits
1	1	8 Bits

Bit 2

This bit specifies the number of stop bits in each transmitted or received serial character. The following table summarizes the information. Note: The receiver will ignore all stop bits beyond the first, regardless of the number used in transmitting.

BIT 2	WORD LENGTH	NUMBER OF STOP BITS
0	--	1
1	5 bits	1.5
1	6 bits	2
1	7 bits	2
1	8 bits	2

Bit 3

Parity Enable bit. When bit 3 is a logic "1", a parity bit is generated (transmit data) or checked (receive data) between the last data word bit and the first stop bit of the serial data. (The parity bit is used to generate an even or odd number of 1s when the data word bits and the parity bit are summed).

Bit 4

Even Parity Select bit. When bit 3 is a logic "1" and bit 4 is a logic "0", an odd number of logic "1"s is transmitted or checked in the data word bits and the parity bit. When bit 3 is a logic "1" and bit 4 is a logic "1" an even number of bits is transmitted and checked.

Bit 5

Stick Parity bit. When bit 3 is a logic "1" and bit 5 is a logic "1", the parity bit is transmitted and then detected by the receiver in the opposite state indicated by bit 4.

Bit 6

Set Break Control bit. When bit 6 is a logic "1", the transmit data output (TXD) is forced to the Spacing or logic "0" state and remains there (until

reset by a low level bit 6) regardless of other transmitter activity. This feature enables the Serial Port to alert a terminal in a communications system.

Bit 7

Divisor Latch Access bit (DLAB). It must be set high (logic "1") to access the Divisor Latches of the Baud Rate Generator during read or write operations. It must be set low (logic "0") to access the Receiver Buffer Register, the Transmitter Holding Register, or the Interrupt Enable Register.

MODEM CONTROL REGISTER (MCR)

Address Offset = 4H, DLAB = X, READ/WRITE

This 8 bit register controls the interface with the MODEM or data set (or device emulating a MODEM). The contents of the MODEM control register are described below.

Bit 0

This bit controls the Data Terminal Ready (nDTR) output. When bit 0 is set to a logic "1", the nDTR output is forced to a logic "0". When bit 0 is a logic "0", the nDTR output is forced to a logic "1".

Bit 1

This bit controls the Request To Send (nRTS) output. Bit 1 affects the nRTS output in a manner identical to that described above for bit 0.

Bit 2

This bit controls the Output 1 (OUT1) bit. This bit does not have an output pin and can only be read or written by the CPU.

Bit 3

Output 2 (OUT2). This bit is used to enable an UART interrupt. When OUT2 is a logic "0", the serial port interrupt output is forced to a high impedance state - disabled. When OUT2 is a logic "1", the serial port interrupt outputs are enabled.

Bit 4

This bit provides the loopback feature for diagnostic testing of the Serial Port. When bit 4 is set to logic "1", the following occur:

1. The TXD is set to the Marking State(logic "1").
2. The receiver Serial Input (RXD) is disconnected.
3. The output of the Transmitter Shift Register is "looped back" into the Receiver Shift Register input.
4. All MODEM Control inputs (nCTS, nDSR, nRI and nDCD) are disconnected.
5. The four MODEM Control outputs (nDTR, nRTS, OUT1 and OUT2) are internally connected to the four MODEM Control inputs (nDSR, nCTS, RI, DCD).
6. The Modem Control output pins are forced inactive high.
7. Data that is transmitted is immediately received.

This feature allows the processor to verify the transmit and receive data paths of the Serial Port. In the diagnostic mode, the receiver and the transmitter interrupts are fully operational. The MODEM Control Interrupts are also operational but the interrupts' sources are now the lower four bits of the MODEM Control Register instead of the MODEM Control inputs. The interrupts are still controlled by the Interrupt Enable Register.

Bits 5 through 7

These bits are permanently set to logic zero.

LINE STATUS REGISTER (LSR)

Address Offset = 5H, DLAB = X, READ/WRITE

Bit 0

Data Ready (DR). It is set to a logic "1" whenever a complete incoming character has been received and transferred into the Receiver Buffer Register or the FIFO. Bit 0 is reset to a logic "0" by reading all of the data in the Receive Buffer Register or the FIFO.

Bit 1

Overrun Error (OE). Bit 1 indicates that data in the Receiver Buffer Register was not read before the next character was transferred into the register, thereby destroying the previous character. In FIFO mode, an overrun error will occur only when the FIFO is full and the next character has been completely received in the shift register, the character in the shift register is overwritten but not transferred to the FIFO. The OE indicator is set to a logic "1" immediately upon detection of an overrun condition, and reset whenever the Line Status Register is read.

Bit 2

Parity Error (PE). Bit 2 indicates that the received data character does not have the correct even or odd parity, as selected by the even parity select bit. The PE is set to a logic "1" upon detection of a parity error and is reset to a logic "0" whenever the Line Status Register is read. In the FIFO mode this error is associated with the particular character in the FIFO it applies to. This error is indicated when the associated character is at the top of the FIFO.

Bit 3

Framing Error (FE). Bit 3 indicates that the received character did not have a valid stop bit. Bit 3 is set to a logic "1" whenever the stop bit following the last data bit or parity bit is detected as a zero bit (Spacing level). The FE is reset to a logic "0" whenever the Line Status Register is read. In the FIFO mode this error is associated with the particular character in the FIFO it applies to. This error is indicated when the associated character is at the top of the FIFO. The Serial Port will try to resynchronize after a framing error. To do this, it assumes that the framing error was due to the next start bit, so it samples this 'start' bit twice and then takes in the 'data'.

Bit 4

Break Interrupt (BI). Bit 4 is set to a logic "1" whenever the received data input is held in the Spacing state (logic "0") for longer than a full word transmission time (that is, the total time of the start bit + data bits + parity bits + stop bits). The BI is reset after the CPU reads the contents of the Line Status Register. In the FIFO mode this error is associated with the particular character in the FIFO it applies to. This error is indicated when the associated character is at the top of the FIFO. When break occurs only one zero character is loaded into the FIFO. Restarting after a break is received, requires the serial data (RXD) to be logic "1" for at least 1/2 bit time.

Note: Bits 1 through 4 are the error conditions that produce a Receiver Line Status Interrupt whenever any of the corresponding conditions are detected and the interrupt is enabled.

Bit 5

Transmitter Holding Register Empty (THRE). Bit 5 indicates that the Serial Port is ready to accept a new character for transmission. In addition, this bit causes the Serial Port to issue an interrupt when the Transmitter Holding Register interrupt enable is set high. The THRE bit is set to a logic "1" when a character is transferred from the Transmitter Holding Register into the Transmitter Shift Register. The bit is reset to logic "0" whenever the CPU loads the Transmitter Holding Register. In the FIFO mode this bit is set when the XMIT FIFO is empty, it is cleared when at least 1 byte is written to the XMIT FIFO. Bit 5 is a read only bit.

Bit 6

Transmitter Empty (TEMT). Bit 6 is set to a logic "1" whenever the Transmitter Holding Register (THR) and Transmitter Shift Register (TSR) are both empty. It is reset to logic "0" whenever either the THR or TSR contains a data character. Bit 6 is a read only bit. In the FIFO mode this bit is set whenever the THR and TSR are both empty,

Bit 7

This bit is permanently set to logic "0" in the 450 mode. In the FIFO mode, this bit is set to a logic "1" when there is at least one parity error, framing error or break indication in the FIFO. This bit is cleared when the LSR is read if there are no subsequent errors in the FIFO.

MODEM STATUS REGISTER (MSR)

Address Offset = 6H, DLAB = X, READ/WRITE

This 8 bit register provides the current state of the control lines from the MODEM (or peripheral device). In addition to this current state information, four bits of the MODEM Status Register (MSR) provide change information. These bits are set to logic "1" whenever a control input from the MODEM changes state. They are reset to logic "0" whenever the MODEM Status Register is read.

Bit 0

Delta Clear To Send (DCTS). Bit 0 indicates that the nCTS input to the chip has changed state since the last time the MSR was read.

Bit 1

Delta Data Set Ready (DDSR). Bit 1 indicates that the nDSR input has changed state since the last time the MSR was read.

Bit 2

Trailing Edge of Ring Indicator (TERI). Bit 2 indicates that the nRI input has changed from logic "0" to logic "1".

Bit 3

Delta Data Carrier Detect (DDCD). Bit 3 indicates that the nDCD input to the chip has changed state.

Note: Whenever bit 0, 1, 2, or 3 is set to a logic "1", a MODEM Status Interrupt is generated.

Bit 4

This bit is the complement of the Clear To Send (nCTS) input. If bit 4 of the MCR is set to logic "1", this bit is equivalent to nRTS in the MCR.

Bit 5

This bit is the complement of the Data Set Ready (nDSR) input. If bit 4 of the MCR is set to logic "1", this bit is equivalent to DTR in the MCR.

Bit 6

This bit is the complement of the Ring Indicator (nRI) input. If bit 4 of the MCR is set to logic "1", this bit is equivalent to OUT1 in the MCR.

Bit 7

This bit is the complement of the Data Carrier Detect (nDCD) input. If bit 4 of the MCR is set to logic "1", this bit is equivalent to OUT2 in the MCR.

SCRATCHPAD REGISTER (SCR)**Address Offset =7H, DLAB =X, READ/WRITE**

This 8 bit read/write register has no effect on the operation of the Serial Port. It is intended as a scratchpad register to be used by the programmer to hold data temporarily.

PROGRAMMABLE BAUD RATE GENERATOR (AND DIVISOR LATCHES DLH, DLL)

The Serial Port contains a programmable Baud Rate Generator that is capable of taking any clock input (DC to 3 MHz) and dividing it by any divisor from 1 to 65535. This output frequency of the Baud Rate Generator is 16x the Baud rate. Two 8 bit latches store the divisor in 16 bit binary format. These Divisor Latches must be loaded during initialization in order to insure desired operation of the Baud Rate Generator. Upon loading either of the Divisor Latches, a 16 bit Baud counter is immediately loaded. This prevents long counts on initial load. If a 0 is loaded into the BRG registers the output divides the clock by the number 3. If a 1 is loaded the output is the inverse of the input oscillator. If a two is loaded the output is a divide by 2 signal with a 50% duty cycle. If a 3 or greater is loaded the output is low for 2 bits and high for the remainder of the count. The input clock to the BRG is a 1.8462 MHz clock.

Table 35 shows the baud rates possible with a 1.8462 MHz crystal.

Table 35 - Baud Rates Using 1.8462 MHz Clock for <= 38.4K; Using 1.8432MHz Clock for 115.2k ; Using 3.6864MHz Clock for 230.4k; Using 7.3728 MHz Clock for 460.8k

DESIRED BAUD RATE	DIVISOR USED TO GENERATE 16X CLOCK	PERCENT ERROR DIFFERENCE BETWEEN DESIRED AND ACTUAL¹	HIGH SPEED BIT²
50	2304	0.001	X
75	1536	-	X
110	1047	-	X
134.5	857	0.004	X
150	768	-	X
300	384	-	X
600	192	-	X
1200	96	-	X
1800	64	-	X
2000	58	0.005	X
2400	48	-	X
3600	32	-	X
4800	24	-	X
7200	16	-	X
9600	12	-	X
19200	6	-	X
38400	3	0.030	X
57600	2	0.16	X
115200	1	0.16	X
230400	32770	0.16	1
460800	32769	0.16	1

Note¹: The percentage error for all baud rates, except where indicated otherwise, is 0.2%.

Note²: The High Speed bit is located in the Device Configuration Space.

Effect Of The Reset on Register File

The Reset Function Table (TABLE 36) details the effect of the Reset input on each of the registers of the Serial Port.

FIFO INTERRUPT MODE OPERATION

When the RCVR FIFO and receiver interrupts are enabled (FCR bit 0 = "1", IER bit 0 = "1"), RCVR interrupts occur as follows:

- A. The receive data available interrupt will be issued when the FIFO has reached its programmed trigger level; it is cleared as soon as the FIFO drops below its programmed trigger level.
- B. The IIR receive data available indication also occurs when the FIFO trigger level is reached. It is cleared when the FIFO drops below the trigger level.
- C. The receiver line status interrupt (IIR=06H), has higher priority than the received data available (IIR=04H) interrupt.
- D. The data ready bit (LSR bit 0) is set as soon as a character is transferred from the shift register to the RCVR FIFO. It is reset when the FIFO is empty.

When RCVR FIFO and receiver interrupts are enabled, RCVR FIFO timeout interrupts occur as follows:

- A. A FIFO timeout interrupt occurs if all the following conditions exist:
 - At least one character is in the FIFO.
 - The most recent serial character received was longer than 4 continuous character times ago. (If 2 stop bits are programmed, the second one is included in this time delay).
 - The most recent CPU read of the FIFO was longer than 4 continuous character times ago.

This will cause a maximum character received to interrupt issued delay of 160 msec at 300 BAUD with a 12 bit character.

- B. Character times are calculated by using the RCLK input for a clock signal (this makes the delay proportional to the baudrate).
- C. When a timeout interrupt has occurred it is cleared and the timer reset when the CPU reads one character from the RCVR FIFO.
- D. When a timeout interrupt has not occurred the timeout timer is reset after a new character is received or after the CPU reads the RCVR FIFO.

When the XMIT FIFO and transmitter interrupts are enabled (FCR bit 0 = "1", IER bit 1 = "1"), XMIT interrupts occur as follows:

- A. The transmitter holding register interrupt (02H) occurs when the XMIT FIFO is empty; it is cleared as soon as the transmitter holding register is written to (1 of 16 characters may be written to the XMIT FIFO while servicing this interrupt) or the IIR is read.
- B. The transmitter FIFO empty indications will be delayed 1 character time minus the last stop bit time whenever the following occurs: THRE=1 and there have not been at least two bytes at the same time in the transmitter FIFO since the last THRE=1. The transmitter interrupt after changing FCR0 will be immediate, if it is enabled.

Character timeout and RCVR FIFO trigger level interrupts have the same priority as the current received data available interrupt; XMIT FIFO empty has the same priority as the current transmitter holding register empty interrupt.

FIFO POLLED MODE OPERATION

With FCR bit 0 = "1" resetting IER bits 0, 1, 2 or 3 or all to zero puts the UART in the FIFO Polled Mode of operation. Since the RCVR and XMITTER are controlled separately, either one or both can be in the polled mode of operation. In this mode, the user's program will check RCVR and XMITTER status via the LSR. LSR definitions for the FIFO Polled Mode are as follows:

- Bit 0=1 as long as there is one byte in the RCVR FIFO.
- Bits 1 to 4 specify which error(s) have occurred. Character error status is handled

the same way as when in the interrupt mode, the IIR is not affected since EIR bit 2=0.

- Bit 5 indicates when the XMIT FIFO is empty.
- Bit 6 indicates that both the XMIT FIFO and shift register are empty.
- Bit 7 indicates whether there are any errors in the RCVR FIFO.

There is no trigger level reached or timeout condition indicated in the FIFO Polled Mode, however, the RCVR and XMIT FIFOs are still fully capable of holding characters.

TABLE 36 - RESET FUNCTION

REGISTER/SIGNAL	RESET CONTROL	RESET STATE
Interrupt Enable Register	RESET	All bits low
Interrupt Identification Reg.	RESET	Bit 0 is high; Bits 1 - 7 low
FIFO Control	RESET	All bits low
Line Control Reg.	RESET	All bits low
MODEM Control Reg.	RESET	All bits low
Line Status Reg.	RESET	All bits low except 5, 6 high
MODEM Status Reg.	RESET	Bits 0 - 3 low; Bits 4 - 7 input
TXD1, TXD2	RESET	High
INTRPT (RCVR errs)	RESET/Read LSR	Low
INTRPT (RCVR Data Ready)	RESET/Read RBR	Low
INTRPT (THRE)	RESET/Read IIR/Write THR	Low
OUT2B	RESET	High
RTSB	RESET	High
DTRB	RESET	High
OUT1B	RESET	High
RCVR FIFO	RESET/ FCR1*FCR0/_FCR0	All Bits Low
XMIT FIFO	RESET/ FCR1*FCR0/_FCR0	All Bits Low

TABLE 37 - REGISTER SUMMARY FOR AN INDIVIDUAL UART CHANNEL

REGISTER ADDRESS*	REGISTER NAME	REGISTER SYMBOL	BIT 0	BIT 1
ADDR = 0 DLAB = 0	Receive Buffer Register (Read Only)	RBR	Data Bit 0 (Note 1)	Data Bit 1
ADDR = 0 DLAB = 0	Transmitter Holding Register (Write Only)	THR	Data Bit 0	Data Bit 1
ADDR = 1 DLAB = 0	Interrupt Enable Register	IER	Enable Received Data Available Interrupt (ERDAI)	Enable Transmitter Holding Register Empty Interrupt (ETHREI)
ADDR = 2	Interrupt Ident. Register (Read Only)	IIR	"0" if Interrupt Pending	Interrupt ID Bit
ADDR = 2	FIFO Control Register (Write Only)	FCR (Note 7)	FIFO Enable	RCVR FIFO Reset
ADDR = 3	Line Control Register	LCR	Word Length Select Bit 0 (WLS0)	Word Length Select Bit 1 (WLS1)
ADDR = 4	MODEM Control Register	MCR	Data Terminal Ready (DTR)	Request to Send (RTS)
ADDR = 5	Line Status Register	LSR	Data Ready (DR)	Overrun Error (OE)
ADDR = 6	MODEM Status Register	MSR	Delta Clear to Send (DCTS)	Delta Data Set Ready (DDSR)
ADDR = 7	Scratch Register (Note 4)	SCR	Bit 0	Bit 1
ADDR = 0 DLAB = 1	Divisor Latch (LS)	DDL	Bit 0	Bit 1
ADDR = 1 DLAB = 1	Divisor Latch (MS)	DLM	Bit 8	Bit 9

*DLAB is Bit 7 of the Line Control Register (ADDR = 3).

Note 1: Bit 0 is the least significant bit. It is the first bit serially transmitted or received.

Note 2: When operating in the XT mode, this bit will be set any time that the transmitter shift register is empty.

TABLE 38 - REGISTER SUMMARY FOR AN INDIVIDUAL UART CHANNEL (CONTINUED)

BIT 2	BIT 3	BIT 4	BIT 5	BIT 6	BIT 7
Data Bit 2	Data Bit 3	Data Bit 4	Data Bit 5	Data Bit 6	Data Bit 7
Data Bit 2	Data Bit 3	Data Bit 4	Data Bit 5	Data Bit 6	Data Bit 7
Enable Receiver Line Status Interrupt (ELSI)	Enable MODEM Status Interrupt (EMSI)	0	0	0	0
Interrupt ID Bit	Interrupt ID Bit (Note 5)	0	0	FIFOs Enabled (Note 5)	FIFOs Enabled (Note 5)
XMIT FIFO Reset	DMA Mode Select (Note 6)	Reserved	Reserved	RCVR Trigger LSB	RCVR Trigger MSB
Number of Stop Bits (STB)	Parity Enable (PEN)	Even Parity Select (EPS)	Stick Parity	Set Break	Divisor Latch Access Bit (DLAB)
OUT1 (Note 3)	OUT2 (Note 3)	Loop	0	0	0
Parity Error (PE)	Framing Error (FE)	Break Interrupt (BI)	Transmitter Holding Register (THRE)	Transmitter Empty (TEMT) (Note 2)	Error in RCVR FIFO (Note 5)
Trailing Edge Ring Indicator (TERI)	Delta Data Carrier Detect (DDCD)	Clear to Send (CTS)	Data Set Ready (DSR)	Ring Indicator (RI)	Data Carrier Detect (DCD)
Bit 2	Bit 3	Bit 4	Bit 5	Bit 6	Bit 7
Bit 2	Bit 3	Bit 4	Bit 5	Bit 6	Bit 7
Bit 10	Bit 11	Bit 12	Bit 13	Bit 14	Bit 15

Note 3: This bit no longer has a pin associated with it.

Note 4: When operating in the XT mode, this register is not available.

Note 5: These bits are always zero in the non-FIFO mode.

Note 6: Writing a one to this bit has no effect. DMA modes are not supported in this chip.

Note 7: The UART1 and UART2 FCR's are shadowed in the UART1 FIFO Control Shadow Register (LD8:CRC3[7:0]) and UART2 FIFO Control Shadow Register (LD8:CRC4[7:0]).

NOTES ON SERIAL PORT OPERATION

FIFO MODE OPERATION:

GENERAL

The RCVR FIFO will hold up to 16 bytes regardless of which trigger level is selected.

TX AND RX FIFO OPERATION

The Tx portion of the UART transmits data through TXD as soon as the CPU loads a byte into the Tx FIFO. **The UART will prevent loads to the Tx FIFO if it currently holds 16 characters.** Loading to the Tx FIFO will again be enabled as soon as the next character is transferred to the Tx shift register. These capabilities account for the largely autonomous operation of the Tx.

The UART starts the above operations typically with a Tx interrupt. The chip issues a Tx interrupt whenever the Tx FIFO is empty and the Tx interrupt is enabled, except in the following instance. Assume that the Tx FIFO is empty and the CPU starts to load it. When the first byte enters the FIFO the Tx FIFO empty interrupt will transition from active to inactive. Depending on the execution speed of the service routine software, the UART may be able to transfer this byte from the FIFO to the shift register before the CPU loads another byte. If this happens, the Tx FIFO will be empty again and typically the UART's interrupt line would transition to the active state. This could cause a system with an interrupt control unit to record a Tx FIFO empty condition, even though the CPU is currently servicing that interrupt. **Therefore, after the first byte has been loaded into the FIFO the UART will wait one serial character transmission time before issuing a new Tx FIFO empty interrupt. This one character Tx interrupt delay will remain active until at least two bytes have the Tx FIFO empties after this condition, the Tx been loaded into the FIFO, concurrently. When interrupt will be activated without a one character delay.**

Rx support functions and operation are quite different from those described for the transmitter.

The Rx FIFO receives data until the number of bytes in the FIFO equals the selected interrupt trigger level. At that time if Rx interrupts are enabled, the UART will issue an interrupt to the CPU. The Rx FIFO will continue to store bytes until it holds 16 of them. It will not accept any more data when it is full. Any more data entering the Rx shift register will set the Overrun Error flag. Normally, the FIFO depth and the programmable trigger levels will give the CPU ample time to empty the Rx FIFO before an overrun occurs.

One side-effect of having a Rx FIFO is that the selected interrupt trigger level may be above the data level in the FIFO. This could occur when data at the end of the block contains fewer bytes than the trigger level. No interrupt would be issued to the CPU and the data would remain in the UART. **To prevent the software from having to check for this situation the chip incorporates a timeout interrupt.**

The timeout interrupt is activated when there is a least one byte in the Rx FIFO, and neither the CPU nor the Rx shift register has accessed the Rx FIFO within 4 character times of the last byte. The timeout interrupt is cleared or reset when the CPU reads the Rx FIFO or another character enters it.

These FIFO related features allow optimization of CPU/UART transactions and are especially useful given the higher baud rate capability (256 kbaud).

Ring Wake Filter

An optional filter is provided to prevent glitches to the wakeup circuitry and prevent unnecessary wakeup of the system when a phone is picked up or hung up. If enabled, this filter will be placed into the soft power management, SMI and PME/SCI wakeup event path of either of the UART ring indicator pins (nRI1, nRI2), or the nRING pin, which is an alternate function on GP11 and GP62.

This feature is enabled onto the nRING pin or one of the ring indicator pins (nRI1, nRI2) via the Ring Filter Select Register defined below. If enabled, a frequency detection filter is placed in the path to the soft power management block, SMI and PME interface that generates an active

low pulse for the duration of a signal that produces 3 edges in a 200msec time period i.e., detects a pulse train of frequency 15Hz or higher.

This filter circuit runs off of the 32 KHz clock. This circuit is powered by the VTR power supply. When this circuit is disabled, it will draw no current.

The nRING function is part of the soft power management block as an additional wakeup event, and the SMI and PME interface logic.

1. A status and enable bit is in the soft power status and enable registers as follows:

- RING Status bit - R/W: RING_STS, Bit 3 of Soft Power Status Register 2 (Logical Device 8, 0xB3); latched, cleared on read. 1= Ring indicator input occurred on the nRING pin and, if enabled, caused the wakeup (activated nPowerOn). 0= nRING input did not occur.
- RING Enable bit - R/W: RING_EN, Bit 3 of Soft Power Enable Register 2 (Logical Device 8, 0xB1). 1=Enable ring indication on nRING pin as wakeup function to activate nPowerOn. 0=Disable.

2. An enable bit is in the SMI Enable Register 1 as follows:

- RING Enable bit - R/W: RING_EN, Bit 0 of SMI Register 1 (System I/O Space, at

<PM1_BLK>+14h). 1=Enable ring indication on nRING pin as SMI function. 0=Disable. Note: the PME status bit for RING is used as the SMI status bit for RING (see PME Status Register).

3. A status and enable bit is in the PME status and enable registers as follows:

- RING Status bit - R/W: RING_STS, Bit 5 of PME Status Register 1 (System I/O Space, at <PM1_BLK>+Ch); latched, cleared by writing a "1" to this bit. 1= Ring indicator input occurred on the nRING pin and, if enabled, caused the nPME/SCI or SMI. 0= nRING input did not occur.
- RING Enable bit - R/W: RING_EN, Bit 5 of PME Enable Register 1 (System I/O Space, at <PM1_BLK>+Eh). 1=Enable ring indication on nRING pin as PME wakeup function. 0=Disable.

Refer to Logical Device 8, 0xC6 for programming information

The ring wakeup filter will produce an active low pulse for the period of time that nRING, nRI1 and/or nRI2 is toggling. See figure below.

RING WAKEUP FILTER OUTPUT

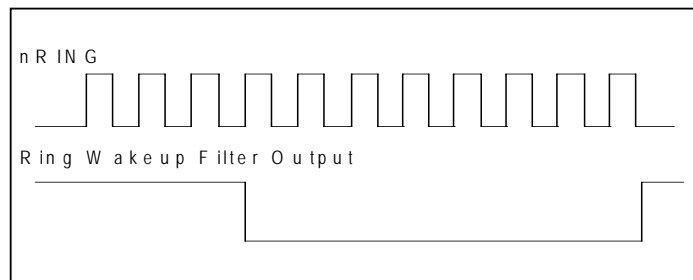

INFRARED INTERFACE

The infrared interface provides a two-way wireless communications port using infrared as a transmission medium. Several IR implementations have been provided for the second UART in this chip (logical device 5), IrDA, Consumer Remote Control, and Amplitude Shift Keyed IR. The IR transmission can use the standard UART2 TXD2 and RXD2 pins or optional IRTX and IRRX pins. These can be selected through the configuration registers.

IrDA 1.0 allows serial communication at baud rates up to 115.2 kbps. Each word is sent serially beginning with a zero value start bit. A zero is signaled by sending a single IR pulse at the beginning of the serial bit time. A one is signaled by sending no IR pulse during the bit time. Please refer to the AC timing for the parameters of these pulses and the IrDA waveform.

The consumer remote control interface can decode NEC PPM remote control frames in hardware as well provide a general-purpose synchronous ASK encoder/decoder with programmable carrier frequency and bit rates to emulate many other popular remote control encoding formats; including 38 kHz PPM, PWM and RC-5. **Consult the SMSC CirCC data sheet for more details.**

The Amplitude Shift Keyed IR allows asynchronous serial communication at baud rates up to 19.2K Baud. Each word is sent serially beginning with a zero value start bit. A zero is signaled by sending a 500KHz waveform for the duration of the serial bit time. A one is signaled by sending no transmission during the bit time. Please refer to the AC timing for the parameters of the ASK-IR waveform.

If the Half-Duplex option is chosen, there is a time-out when the direction of the transmission is changed. This time-out starts at the last bit transferred during a transmission and blocks the receiver input until the timeout expires. If the transmit buffer is loaded with more data before the time-out expires, the timer is restarted after the new byte is transmitted. If data is loaded into the transmit buffer while a character is being received, the transmission will not start until the time-out expires after the last receive bit has been received. If the start bit of another character is received during this time-out, the timer is restarted after the new character is received. The IR half-duplex time-out is programmable via CRF2 in Logical Device 5. This register allows the time-out to be programmed to any value between 0 and 10msec in 100usec increments.

PARALLEL PORT

This chip incorporates an IBM XT/AT compatible parallel port. This supports the optional PS/2 type bi-directional parallel port (SPP), the Enhanced Parallel Port (EPP) and the Extended Capabilities Port (ECP) parallel port modes. Refer to the Configuration Registers for information on disabling, power down, changing the base address of the parallel port, and selecting the mode of operation.

This chip also provides a mode for support of the floppy disk controller on the parallel port. The parallel port also incorporates SMSC's ChiProtect circuitry, which prevents possible

damage to the parallel port due to printer power-up.

The functionality of the Parallel Port is achieved through the use of eight addressable ports, with their associated registers and control gating. The control and data port are read/write by the CPU, the status port is read/write in the EPP mode. The address map of the Parallel Port is shown below:

DATA PORT	BASE ADDRESS + 00H
STATUS PORT	BASE ADDRESS + 01H
CONTROL PORT	BASE ADDRESS + 02H
EPP ADDR PORT	BASE ADDRESS + 03H
EPP DATA PORT 0	BASE ADDRESS + 04H

EPP DATA PORT 1 BASE ADDRESS + 05H
 EPP DATA PORT 2 BASE ADDRESS + 06H
 EPP DATA PORT 3 BASE ADDRESS + 07H

The bit map of these registers is:

	D0	D1	D2	D3	D4	D5	D6	D7	Note
DATA PORT	PD0	PD1	PD2	PD3	PD4	PD5	PD6	PD7	1
STATUS PORT	TMOUT	0	0	nERR	SLCT	PE	nACK	nBUSY	1
CONTROL PORT	STROBE	AUTOFD	nINIT	SLC	IRQE	PCD	0	0	1
EPP ADDR PORT	PD0	PD1	PD2	PD3	PD4	PD5	PD6	AD7	2,3
EPP DATA PORT 0	PD0	PD1	PD2	PD3	PD4	PD5	PD6	PD7	2,3
EPP DATA PORT 1	PD0	PD1	PD2	PD3	PD4	PD5	PD6	PD7	2,3
EPP DATA PORT 2	PD0	PD1	PD2	PD3	PD4	PD5	PD6	PD7	2,3
EPP DATA PORT 3	PD0	PD1	PD2	PD3	PD4	PD5	PD6	PD7	2,3

Note 1: These registers are available in all modes.

Note 2: These registers are only available in EPP mode.

Note 3: For EPP mode, IOCHRDY must be connected to the ISA bus.

TABLE 39 - PARALLEL PORT CONNECTOR

HOST CONNECTOR	PIN NUMBER	STANDARD	EPP	ECP
1		nStrobe	nWrite	nStrobe
2-9		PData<0:7>	PData<0:7>	PData<0:7>
10		nAck	Intr	nAck
11		Busy	nWait	Busy, PeriphAck(3)
12		PE	(NU)	PError, nAckReverse(3)
13		Select	(NU)	Select
14		nAutofd	nDatastb	nAutoFd, HostAck(3)
15		nError	(NU)	nFault(1) nPeriphRequest(3)
16		nInit	(NU)	nInit(1) nReverseRqst(3)
17		nSelectin	nAddrstrb	nSelectIn(1,3)

(1) = Compatible Mode
 (3) = High Speed Mode

Note: For the cable interconnection required for ECP support and the Slave Connector pin numbers, refer to the IEEE 1284 Extended Capabilities Port Protocol and ISA Standard, Rev. 1.14, July 14, 1993. This document is available from Microsoft.

IBM XT/AT COMPATIBLE, BI-DIRECTIONAL AND EPP MODES

DATA PORT

ADDRESS OFFSET = 00H

The Data Port is located at an offset of '00H' from the base address. The data register is cleared at initialization by RESET. During a WRITE operation, the Data Register latches the contents of the data bus with the rising edge of the nIOW input. The contents of this register are buffered (non inverting) and output onto the PD0 - PD7 ports. During a READ operation in SPP mode, PD0 - PD7 ports are buffered (not latched) and output to the host CPU.

STATUS PORT

ADDRESS OFFSET = 01H

The Status Port is located at an offset of '01H' from the base address. The contents of this register are latched for the duration of an nIOR read cycle. The bits of the Status Port are defined as follows:

BIT 0 TMOUT - TIME OUT

This bit is valid in EPP mode only and indicates that a 10 usec time out has occurred on the EPP bus. A logic 0 means that no time out error has occurred; a logic 1 means that a time out error has been detected. This bit is cleared by a RESET. Writing a one to this bit clears the time out status bit. On a write, this bit is self clearing and does not require a write of a zero. Writing a zero to this bit has no effect.

BITS 1, 2 - are not implemented as register bits, during a read of the Printer Status Register these bits are a low level.

BIT 3 nERR - nERROR

The level on the nERROR input is read by the CPU as bit 3 of the Printer Status Register. A logic 0 means an error has been detected; a logic 1 means no error has been detected.

BIT 4 SLCT - PRINTER SELECTED STATUS

The level on the SLCT input is read by the CPU as bit 4 of the Printer Status Register. A logic 1 means the printer is on line; a logic 0 means it is not selected.

BIT 5 PE - PAPER END

The level on the PE input is read by the CPU as bit 5 of the Printer Status Register. A logic 1 indicates a paper end; a logic 0 indicates the presence of paper.

BIT 6 nACK - nACKNOWLEDGE

The level on the nACK input is read by the CPU as bit 6 of the Printer Status Register. A logic 0 means that the printer has received a character and can now accept another. A logic 1 means that it is still processing the last character or has not received the data.

BIT 7 nBUSY - nBUSY

The complement of the level on the BUSY input is read by the CPU as bit 7 of the Printer Status Register. A logic 0 in this bit means that the printer is busy and cannot accept a new character. A logic 1 means that it is ready to accept the next character.

CONTROL PORT

ADDRESS OFFSET = 02H

The Control Port is located at an offset of '02H' from the base address. The Control Register is initialized by the RESET input, bits 0 to 5 only being affected; bits 6 and 7 are hard wired low.

BIT 0 STROBE - STROBE

This bit is inverted and output onto the nSTROBE output.

BIT 1 AUTOFD - AUTOFEED

This bit is inverted and output onto the nAUTOFD output. A logic 1 causes the printer to generate a line feed after each line is printed. A logic 0 means no autofeed.

BIT 2 nINIT - nINITIATE OUTPUT

This bit is output onto the nINIT output without inversion.

BIT 3 SLCTIN - PRINTER SELECT INPUT

This bit is inverted and output onto the nSLCTIN output. A logic 1 on this bit selects the printer; a logic 0 means the printer is not selected.

BIT 4 IRQE - INTERRUPT REQUEST ENABLE

The interrupt request enable bit when set to a high level may be used to enable interrupt requests from the Parallel Port to the CPU. An interrupt request is generated on the IRQ port by a positive going nACK input. When the IRQE bit is programmed low the IRQ is disabled.

BIT 5 PCD - PARALLEL CONTROL DIRECTION

Parallel Control Direction is not valid in printer mode. In printer mode, the direction is always out regardless of the state of this bit. In bi-directional, EPP or ECP mode, a logic 0 means that the printer port is in output mode (write); a logic 1 means that the printer port is in input mode (read).

Bits 6 and 7 during a read are a low level, and cannot be written.

EPP ADDRESS PORT

ADDRESS OFFSET = 03H

The EPP Address Port is located at an offset of '03H' from the base address. The address register is cleared at initialization by RESET. During a WRITE operation, the contents of DB0-DB7 are buffered (non inverting) and output onto the PD0 - PD7 ports, the leading edge of nIOW causes an EPP ADDRESS WRITE cycle to be performed, the trailing edge of IOW latches the data for the duration of the EPP write cycle. During a READ operation, PD0 - PD7 ports are read, the leading edge of IOR causes an EPP ADDRESS READ cycle to be performed and the data output to the host CPU, the deassertion of ADDRSTB latches the PData for the duration of the IOR cycle. This register is only available in EPP mode.

EPP DATA PORT 0

ADDRESS OFFSET = 04H

The EPP Data Port 0 is located at an offset of '04H' from the base address. The data register is

cleared at initialization by RESET. During a WRITE operation, the contents of DB0-DB7 are buffered (non inverting) and output onto the PD0 - PD7 ports, the leading edge of nIOW causes an EPP DATA WRITE cycle to be performed, the trailing edge of IOW latches the data for the duration of the EPP write cycle. During a READ operation, PD0 - PD7 ports are read, the leading edge of IOR causes an EPP READ cycle to be performed and the data output to the host CPU, the deassertion of DATASTB latches the PData for the duration of the IOR cycle. This register is only available in EPP mode.

EPP DATA PORT 1

ADDRESS OFFSET = 05H

The EPP Data Port 1 is located at an offset of '05H' from the base address. Refer to EPP DATA PORT 0 for a description of operation. This register is only available in EPP mode.

EPP DATA PORT 2

ADDRESS OFFSET = 06H

The EPP Data Port 2 is located at an offset of '06H' from the base address. Refer to EPP DATA PORT 0 for a description of operation. This register is only available in EPP mode.

EPP DATA PORT 3

ADDRESS OFFSET = 07H

The EPP Data Port 3 is located at an offset of '07H' from the base address. Refer to EPP DATA PORT 0 for a description of operation. This register is only available in EPP mode.

EPP 1.9 OPERATION

When the EPP mode is selected in the configuration register, the standard and bi-directional modes are also available. If no EPP Read, Write or Address cycle is currently executing, then the PDx bus is in the standard or bi-directional mode, and all output signals (STROBE, AUTOFD, INIT) are as set by the SPP Control Port and direction is controlled by PCD of the Control port.

In EPP mode, the system timing is closely coupled to the EPP timing. For this reason, a watchdog timer is required to prevent system lockup. The timer indicates if more than 10µsec have elapsed from the start of the EPP cycle (nIOR or nIOW asserted) to nWAIT being deasserted (after command). If a time-out occurs, the current EPP cycle is aborted and the time-out condition is indicated in Status bit 0.

During an EPP cycle, if STROBE is active, it overrides the EPP write signal forcing the PDx bus to always be in a write mode and the nWRITE signal to always be asserted.

Software Constraints

Before an EPP cycle is executed, the software must ensure that the control register bit PCD is a logic "0" (ie a 04H or 05H should be written to the Control port). If the user leaves PCD as a logic "1", and attempts to perform an EPP write, the chip is unable to perform the write (because PCD is a logic "1") and will appear to perform an EPP read on the parallel bus, no error is indicated.

EPP 1.9 Write

The timing for a write operation (address or data) is shown in timing diagram EPP Write Data or Address cycle. IOCHRDY is driven active low at the start of each EPP write and is released when it has been determined that the write cycle can complete. The write cycle can complete under the following circumstances:

1. If the EPP bus is not ready (nWAIT is active low) when nDATASTB or nADDRSTB goes active then the write can complete when nWAIT goes inactive high.
2. If the EPP bus is ready (nWAIT is inactive high) then the chip must wait for it to go active low before changing the state of nDATASTB, nWRITE or nADDRSTB. The write can complete once nWAIT is determined inactive.

Write Sequence of operation

1. The host selects an EPP register, places data on the SData bus and drives nIOW active.
2. The chip drives IOCHRDY inactive (low).
3. If WAIT is not asserted, the chip must wait until WAIT is asserted.
4. The chip places address or data on PData bus, clears PDIR, and asserts nWRITE.
5. Chip asserts nDATASTB or nADDRSTRB indicating that PData bus contains valid information, and the WRITE signal is valid.
6. Peripheral deasserts nWAIT, indicating that any setup requirements have been satisfied and the chip may begin the termination phase of the cycle.
 - a) The chip deasserts nDATASTB or nADDRSTRB, this marks the beginning of the termination phase. If it has not already done so, the peripheral should latch the information byte now.
 - b) The chip latches the data from the SData bus for the PData bus and asserts (releases) IOCHRDY allowing the host to complete the write cycle.
8. Peripheral asserts nWAIT, indicating to the host that any hold time requirements have been satisfied and acknowledging the termination of the cycle.
9. Chip may modify nWRITE and nPDATA in preparation for the next cycle.

EPP 1.9 Read

The timing for a read operation (data) is shown in timing diagram EPP Read Data cycle. IOCHRDY is driven active low at the start of each EPP read and is released when it has been determined that the read cycle can complete. The read cycle can complete under the following circumstances:

1. If the EPP bus is not ready (nWAIT is active low) when nDATASTB goes active then the read can complete when nWAIT goes inactive high.
2. If the EPP bus is ready (nWAIT is inactive high) then the chip must wait for it to go active low before changing the state of WRITE or before nDATASTB goes active. The read can complete once nWAIT is determined inactive.

Read Sequence of Operation

1. The host selects an EPP register and drives nIOR active.
2. The chip drives IOCHRDY inactive (low).
3. If WAIT is not asserted, the chip must wait until WAIT is asserted.
4. The chip tri-states the PData bus and deasserts nWRITE.
5. Chip asserts nDATASTB or nADDRSTRB indicating that PData bus is tri-stated, PDIR is set and the nWRITE signal is valid.
6. Peripheral drives PData bus valid.
7. Peripheral deasserts nWAIT, indicating that PData is valid and the chip may begin the termination phase of the cycle.
8. a) The chip latches the data from the PData bus for the SData bus and deasserts nDATASTB or nADDRSTRB. This marks the beginning of the termination phase.
b) The chip drives the valid data onto the SData bus and asserts (releases) IOCHRDY allowing the host to complete the read cycle.
9. Peripheral tri-states the PData bus and asserts nWAIT, indicating to the host that the PData bus is tri-stated.
10. Chip may modify nWRITE, PDIR and nPDATA in preparation for the next cycle.

EPP 1.7 OPERATION

When the EPP 1.7 mode is selected in the configuration register, the standard and bi-directional modes are also available. If no EPP Read, Write or Address cycle is currently executing, then the PDx bus is in the standard or bi-directional mode, and all output signals (STROBE, AUTOFD, INIT) are as set by the SPP Control Port and direction is controlled by PCD of the Control port.

In EPP mode, the system timing is closely coupled to the EPP timing. For this reason, a watchdog timer is required to prevent system lockup. The timer indicates if more than 10usec have elapsed from the start of the EPP cycle (nIOR or nIOW asserted) to the end of the cycle nIOR or nIOW deasserted). If a time-out occurs, the current EPP

cycle is aborted and the time-out condition is indicated in Status bit 0.

Software Constraints

Before an EPP cycle is executed, the software must ensure that the control register bits D0, D1 and D3 are set to zero. Also, bit D5 (PCD) is a logic "0" for an EPP write or a logic "1" for an EPP read.

EPP 1.7 Write

The timing for a write operation (address or data) is shown in timing diagram EPP 1.7 Write Data or Address cycle. IOCHRDY is driven active low when nWAIT is active low during the EPP cycle. This can be used to extend the cycle time. The write cycle can complete when nWAIT is inactive high.

Write Sequence of Operation

1. The host sets PDIR bit in the control register to a logic "0". This asserts nWRITE.
2. The host selects an EPP register, places data on the SData bus and drives nIOW active.
3. The chip places address or data on PData bus.
4. Chip asserts nDATASTB or nADDRSTRB indicating that PData bus contains valid information, and the WRITE signal is valid.
5. If nWAIT is asserted, IOCHRDY is deasserted until the peripheral deasserts nWAIT or a time-out occurs.
6. When the host deasserts nIOW the chip deasserts nDATASTB or nADDRSTRB and latches the data from the SData bus for the PData bus.
7. Chip may modify nWRITE, PDIR and nPDATA in preparation of the next cycle.

EPP 1.7 Read

The timing for a read operation (data) is shown in timing diagram EPP 1.7 Read Data cycle. IOCHRDY is driven active low when nWAIT is active low during the EPP cycle. This can be used to extend the cycle time. The read cycle can complete when nWAIT is inactive high.

Read Sequence of Operation

1. The host sets PDIR bit in the control register to a logic "1". This deasserts nWRITE and tri-states the PData bus.
2. The host selects an EPP register and drives nIOR active.
3. Chip asserts nDATASTB or nADDRSTRB indicating that PData bus is tri-stated, PDIR is set and the nWRITE signal is valid.
4. If nWAIT is asserted, IOCHRDY is deasserted until the peripheral deasserts nWAIT or a time-out occurs.
5. The Peripheral drives PData bus valid.
6. The Peripheral deasserts nWAIT, indicating that PData is valid and the chip may begin the termination phase of the cycle.
7. When the host deasserts nIOR the chip deasserts nDATASTB or nADDRSTRB.
8. Peripheral tri-states the PData bus.
9. Chip may modify nWRITE, PDIR and nPDATA in preparation of the next cycle.

TABLE 40 - EPP PIN DESCRIPTIONS

EPP SIGNAL	EPP NAME	TYPE	EPP DESCRIPTION
nWRITE	nWrite	O	This signal is active low. It denotes a write operation.
PD<0:7>	Address/Data	I/O	Bi-directional EPP byte wide address and data bus.
INTR	Interrupt	I	This signal is active high and positive edge triggered. (Pass through with no inversion, Same as SPP).
WAIT	nWait	I	This signal is active low. It is driven inactive as a positive acknowledgement from the device that the transfer of data is completed. It is driven active as an indication that the device is ready for the next transfer.
DATASTB	nData Strobe	O	This signal is active low. It is used to denote data read or write operation.
RESET	nReset	O	This signal is active low. When driven active, the EPP device is reset to its initial operational mode.
ADDRSTB	nAddress Strobe	O	This signal is active low. It is used to denote address read or write operation.
PE	Paper End	I	Same as SPP mode.
SLCT	Printer Selected Status	I	Same as SPP mode.
nERR	Error	I	Same as SPP mode.
PDIR	Parallel Port Direction	O	This output shows the direction of the data transfer on the parallel port bus. A low means an output/write condition and a high means an input/read condition. This signal is normally a low (output/write) unless PCD of the control register is set or if an EPP read cycle is in progress.

Note 1: SPP and EPP can use 1 common register.

Note 2: nWrite is the only EPP output that can be over-riden by SPP control port during an EPP cycle. For correct EPP read cycles, PCD is required to be a low.

EXTENDED CAPABILITIES PARALLEL PORT

ECP provides a number of advantages, some of which are listed below. The individual features are explained in greater detail in the remainder of this section.

- High performance half-duplex forward and reverse channel
- Interlocked handshake, for fast reliable transfer
- Optional single byte RLE compression for improved throughput (64:1)
- Channel addressing for low-cost peripherals
- Maintains link and data layer separation
- Permits the use of active output drivers
- Permits the use of adaptive signal timing
- Peer-to-peer capability

Vocabulary

The following terms are used in this document:

assert: When a signal asserts it transitions to a "true" state, when a signal deasserts it transitions to a "false" state.

forward: Host to Peripheral communication.

reverse: Peripheral to Host communication

Pword: A port word; equal in size to the width of the ISA interface. For this implementation, PWord is always 8 bits.

1 A high level.

0 A low level.

These terms may be considered synonymous:

- PeriphClk, nAck
- HostAck, nAutoFd
- PeriphAck, Busy
- nPeriphRequest, nFault
- nReverseRequest, nInit
- nAckReverse, PError
- Xflag, Select
- ECPMode, nSelectIn
- HostClk, nStrobe

Reference Document: IEEE 1284 Extended Capabilities Port Protocol and ISA Interface Standard, Rev 1.14, July 14, 1993. This document is available from Microsoft.

The bit map of the Extended Parallel Port registers is:

	D7	D6	D5	D4	D3	D2	D1	D0	Note
data	PD7	PD6	PD5	PD4	PD3	PD2	PD1	PD0	
ecpAFifo	Addr/RLE	Address or RLE field							2
dsr	nBusy	nAck	PError	Select	nFault	0	0	0	1
dcr	0	0	Direction	ackIntrEn	SelectIn	nInit	autofd	strobe	1
cFifo	Parallel Port Data FIFO								2
ecpDFifo	ECP Data FIFO								2
tFifo	Test FIFO								2
cnfgA	0	0	0	1	0	0	0	0	
cnfgB	compress	intrValue	Parallel Port IRQ			Parallel Port DMA			
ecr	MODE			nErrIntrEn	dmaEn	serviceIntr	full	empty	

Note 1: These registers are available in all modes.

Note 2: All FIFOs use one common 16 byte FIFO.

Note 3: The ECP Parallel Port Config Reg B reflects the IRQ and DRQ selected by the Configuration Registers.

ISA IMPLEMENTATION STANDARD

This specification describes the standard ISA interface to the Extended Capabilities Port (ECP). All ISA devices supporting ECP must meet the requirements contained in this section or the port will not be supported by Microsoft. For a description of the ECP Protocol, please refer to the [IEEE 1284 Extended Capabilities Port Protocol and ISA Interface Standard](#), Rev. 1.14, July 14, 1993. This document is available from Microsoft.

Description

The port is software and hardware compatible with existing parallel ports so that it may be used as a standard LPT port if ECP is not required. The port is designed to be simple and requires a small number of gates to implement. It does not do any "protocol" negotiation, rather it provides an automatic high burst-bandwidth channel that

supports DMA for ECP in both the forward and reverse directions.

Small FIFOs are employed in both forward and reverse directions to smooth data flow and improve the maximum bandwidth requirement. The size of the FIFO is 16 bytes deep. The port supports an automatic handshake for the standard parallel port to improve compatibility mode transfer speed.

The port also supports run length encoded (RLE) decompression (required) in hardware. Compression is accomplished by counting identical bytes and transmitting an RLE byte that indicates how many times the next byte is to be repeated. Decompression simply intercepts the RLE byte and repeats the following byte the specified number of times. Hardware support for compression is optional.

TABLE 41 - ECP PIN DESCRIPTIONS

NAME	TYPE	DESCRIPTION
nStrobe	O	During write operations nStrobe registers data or address into the slave on the asserting edge (handshakes with Busy).
PData 7:0	I/O	Contains address or data or RLE data.
nAck	I	Indicates valid data driven by the peripheral when asserted. This signal handshakes with nAutoFd in reverse.
PeriphAck (Busy)	I	This signal deasserts to indicate that the peripheral can accept data. This signal handshakes with nStrobe in the forward direction. In the reverse direction this signal indicates whether the data lines contain ECP command information or data. The peripheral uses this signal to flow control in the forward direction. It is an "interlocked" handshake with nStrobe. PeriphAck also provides command information in the reverse direction.
PError (nAckReverse)	I	Used to acknowledge a change in the direction the transfer (asserted = forward). The peripheral drives this signal low to acknowledge nReverseRequest. It is an "interlocked" handshake with nReverseRequest. The host relies upon nAckReverse to determine when it is permitted to drive the data bus.
Select	I	Indicates printer on line.
nAutoFd (HostAck)	O	Requests a byte of data from the peripheral when asserted, handshaking with nAck in the reverse direction. In the forward direction this signal indicates whether the data lines contain ECP address or data. The host drives this signal to flow control in the reverse direction. It is an "interlocked" handshake with nAck. HostAck also provides command information in the forward phase.
nFault (nPeriphRequest)	I	Generates an error interrupt when asserted. This signal provides a mechanism for peer-to-peer communication. This signal is valid only in the forward direction. During ECP Mode the peripheral is permitted (but not required) to drive this pin low to request a reverse transfer. The request is merely a "hint" to the host; the host has ultimate control over the transfer direction. This signal would be typically used to generate an interrupt to the host CPU.
nInit	O	Sets the transfer direction (asserted = reverse, deasserted = forward). This pin is driven low to place the channel in the reverse direction. The peripheral is only allowed to drive the bi-directional data bus while in ECP Mode and HostAck is low and nSelectIn is high.
nSelectIn	O	Always deasserted in ECP mode.

Register Definitions

The register definitions are based on the standard IBM addresses for LPT. All of the standard printer ports are supported. The additional registers attach to an upper bit decode of the standard LPT port definition to avoid conflict with standard ISA

devices. The port is equivalent to a generic parallel port interface and may be operated in that mode. The port registers vary depending on the mode field in the ecr. The table below lists these dependencies. Operation of the devices in modes other than those specified is undefined.

TABLE 42 - ECP REGISTER DEFINITIONS

NAME	ADDRESS (Note 1)	ECP MODES	FUNCTION
data	+000h R/W	000-001	Data Register
ecpAFifo	+000h R/W	011	ECP FIFO (Address)
dsr	+001h R/W	All	Status Register
dcr	+002h R/W	All	Control Register
cFifo	+400h R/W	010	Parallel Port Data FIFO
ecpDFifo	+400h R/W	011	ECP FIFO (DATA)
tFifo	+400h R/W	110	Test FIFO
cnfgA	+400h R	111	Configuration Register A
cnfgB	+401h R/W	111	Configuration Register B
ecr	+402h R/W	All	Extended Control Register

Note 1: These addresses are added to the parallel port base address as selected by configuration register or jumpers.

Note 2: All addresses are qualified with AEN. Refer to the AEN pin definition.

TABLE 43 - MODE DESCRIPTIONS

MODE	DESCRIPTION*
000	SPP mode
001	PS/2 Parallel Port mode
010	Parallel Port Data FIFO mode
011	ECP Parallel Port mode
100	EPP mode (If this option is enabled in the configuration registers)
101	Reserved
110	Test mode
111	Configuration mode

*Refer to ECR Register Description

DATA and ecpAFifo PORT
ADDRESS OFFSET = 00H

Modes 000 and 001 (Data Port)

The Data Port is located at an offset of '00H' from the base address. The data register is cleared at initialization by RESET. During a WRITE operation, the Data Register latches the contents of the data bus on the rising edge of the nIOW input. The contents of this register are buffered (non inverting) and output onto the PD0 - PD7 ports. During a READ operation, PD0 - PD7 ports are read and output to the host CPU.

Mode 011 (ECP FIFO - Address/RLE)

A data byte written to this address is placed in the FIFO and tagged as an ECP Address/RLE. The hardware at the ECP port transmits this byte to the peripheral automatically. The operation of this register is only defined for the forward direction (direction is 0). Refer to the ECP Parallel Port Forward Timing Diagram, located in the Timing Diagrams section of this data sheet .

DEVICE STATUS REGISTER (dsr)
ADDRESS OFFSET = 01H

The Status Port is located at an offset of '01H' from the base address. Bits 0 - 2 are not implemented as register bits, during a read of the Printer Status Register these bits are a low level. The bits of the Status Port are defined as follows:

BIT 3 nFault

The level on the nFault input is read by the CPU as bit 3 of the Device Status Register.

BIT 4 Select

The level on the Select input is read by the CPU as bit 4 of the Device Status Register.

BIT 5 PError

The level on the PError input is read by the CPU as bit 5 of the Device Status Register. Printer Status Register.

BIT 6 nAck

The level on the nAck input is read by the CPU as bit 6 of the Device Status Register.

BIT 7 nBusy

The complement of the level on the BUSY input is read by the CPU as bit 7 of the Device Status Register.

DEVICE CONTROL REGISTER (dcr)
ADDRESS OFFSET = 02H

The Control Register is located at an offset of '02H' from the base address. The Control Register is initialized to zero by the RESET input, bits 0 to 5 only being affected; bits 6 and 7 are hard wired low.

BIT 0 STROBE - STROBE

This bit is inverted and output onto the nSTROBE output.

BIT 1 AUTOFD - AUTOFEED

This bit is inverted and output onto the nAUTOFD output. A logic 1 causes the printer to generate a line feed after each line is printed. A logic 0 means no autofeed.

BIT 2 nINIT - nINITIATE OUTPUT

This bit is output onto the nINIT output without inversion.

BIT 3 SELECTIN

This bit is inverted and output onto the nSLCTIN output. A logic 1 on this bit selects the printer; a logic 0 means the printer is not selected.

BIT 4 ackIntEn - INTERRUPT REQUEST ENABLE

The interrupt request enable bit when set to a high level may be used to enable interrupt requests from the Parallel Port to the CPU due to a low to high transition on the nACK input. Refer to the description of the interrupt under Operation, Interrupts.

BIT 5 DIRECTION

If mode=000 or mode=010, this bit has no effect and the direction is always out regardless of the state of this bit. In all other modes, Direction is valid and a logic 0 means that the printer port is in output mode (write); a logic 1 means that the printer port is in input mode (read).

BITS 6 and 7 during a read are a low level, and cannot be written.

cFifo (Parallel Port Data FIFO)

ADDRESS OFFSET = 400h

Mode = 010

Bytes written or DMAed from the system to this FIFO are transmitted by a hardware handshake to the peripheral using the standard parallel port protocol. Transfers to the FIFO are byte aligned. This mode is only defined for the forward direction.

ecpDFifo (ECP Data FIFO)

ADDRESS OFFSET = 400H

Mode = 011

Bytes written or DMAed from the system to this FIFO, when the direction bit is 0, are transmitted by a hardware handshake to the peripheral using the ECP parallel port protocol. Transfers to the FIFO are byte aligned.

Data bytes from the peripheral are read under automatic hardware handshake from ECP into this FIFO when the direction bit is 1. Reads or DMAs from the FIFO will return bytes of ECP data to the system.

tFifo (Test FIFO Mode)

ADDRESS OFFSET = 400H

Mode = 110

Data bytes may be read, written or DMAed to or from the system to this FIFO in any direction. Data in the tFIFO will not be transmitted to the parallel port lines using a hardware protocol handshake. However, data in the tFIFO may be displayed on the parallel port data lines.

The tFIFO will not stall when overwritten or underrun. If an attempt is made to write data to a full tFIFO, the new data is not accepted into the

tFIFO. If an attempt is made to read data from an empty tFIFO, the last data byte is re-read again. The full and empty bits must always keep track of the correct FIFO state. The tFIFO will transfer data at the maximum ISA rate so that software may generate performance metrics.

The FIFO size and interrupt threshold can be determined by writing bytes to the FIFO and checking the full and serviceIntr bits.

The writeIntrThreshold can be determined by starting with a full tFIFO, setting the direction bit to 0 and emptying it a byte at a time until serviceIntr is set. This may generate a spurious interrupt, but will indicate that the threshold has been reached.

The readIntrThreshold can be determined by setting the direction bit to 1 and filling the empty tFIFO a byte at a time until serviceIntr is set. This may generate a spurious interrupt, but will indicate that the threshold has been reached.

Data bytes are always read from the head of tFIFO regardless of the value of the direction bit. For example if 44h, 33h, 22h is written to the FIFO, then reading the tFIFO will return 44h, 33h, 22h in the same order as was written.

cnfgA (Configuration Register A)

ADDRESS OFFSET = 400H

Mode = 111

This register is a read only register. When read, 10H is returned. This indicates to the system that this is an 8-bit implementation. (PWord = 1 byte)

cnfgB (Configuration Register B)

ADDRESS OFFSET = 401H

Mode = 111

BIT 7 compress

This bit is read only. During a read it is a low level. This means that this chip does not support hardware RLE compression. It does support hardware de-compression!

BIT 6 intrValue

Returns the value on the ISA IRq line to determine possible conflicts.

BITS [5:3] Parallel Port IRQ (read-only)

Refer to Table 44B.

BITS [2:0] Parallel Port DMA (read-only)

Refer to Table 44C.

ecr (Extended Control Register)**ADDRESS OFFSET = 402H**

Mode = all

This register controls the extended ECP parallel port functions.

BITS 7,6,5

These bits are Read/Write and select the Mode.

BIT 4 nErrIntrEn

Read/Write (Valid only in ECP Mode)

- 1: Disables the interrupt generated on the asserting edge of nFault.
- 0: Enables an interrupt pulse on the high to low edge of nFault. Note that an interrupt will be generated if nFault is asserted (interrupting) and this bit is written from a 1 to a 0. This prevents interrupts from being lost in the time between the read of the ecr and the write of the ecr.

BIT 3 dmaEn

Read/Write

- 1: Enables DMA (DMA starts when serviceIntr is 0).
- 0: Disables DMA unconditionally.

BIT 2 serviceIntr

Read/Write

- 1: Disables DMA and all of the service interrupts.
- 0: Enables one of the following 3 cases of interrupts. Once one of the 3 service interrupts has occurred serviceIntr bit shall be set to a 1 by hardware. It must be reset to 0 to re-enable the interrupts. Writing this bit to a 1 will not cause an interrupt.

case dmaEn=1:

During DMA (this bit is set to a 1 when terminal count is reached).

case dmaEn=0 direction=0:

This bit shall be set to 1 whenever there are writeIntrThreshold or more bytes free in the FIFO.

case dmaEn=0 direction=1:

This bit shall be set to 1 whenever there are readIntrThreshold or more valid bytes to be read from the FIFO.

BIT 1 full

Read only

- 1: The FIFO cannot accept another byte or the FIFO is completely full.
- 0: The FIFO has at least 1 free byte.

BIT 0 empty

Read only

- 1: The FIFO is completely empty.
- 0: The FIFO contains at least 1 byte of data.

TABLE 44 - EXTENDED CONTROL REGISTER

R/W	MODE
000:	Standard Parallel Port Mode . In this mode the FIFO is reset and common collector drivers are used on the control lines (nStrobe, nAutoFd, nInIt and nSelectIn). Setting the direction bit will not tri-state the output drivers in this mode.
001:	PS/2 Parallel Port Mode. Same as above except that direction may be used to tri-state the data lines and reading the data register returns the value on the data lines and not the value in the data register. All drivers have active pull-ups (push-pull).
010:	Parallel Port FIFO Mode. This is the same as 000 except that bytes are written or DMAed to the FIFO. FIFO data is automatically transmitted using the standard parallel port protocol. Note that this mode is only useful when direction is 0. All drivers have active pull-ups (push-pull).
011:	ECP Parallel Port Mode. In the forward direction (direction is 0) bytes placed into the ecpDFifo and bytes written to the ecpAFifo are placed in a single FIFO and transmitted automatically to the peripheral using ECP Protocol. In the reverse direction (direction is 1) bytes are moved from the ECP parallel port and packed into bytes in the ecpDFifo. All drivers have active pull-ups (push-pull).
100:	Selects EPP Mode: In this mode, EPP is selected if the EPP supported option is selected in configuration register L3-CRF0. All drivers have active pull-ups (push-pull).
101:	Reserved
110:	Test Mode. In this mode the FIFO may be written and read, but the data will not be transmitted on the parallel port. All drivers have active pull-ups (push-pull).
111:	Configuration Mode. In this mode the configA, configB registers are accessible at 0x400 and 0x401. All drivers have active pull-ups (push-pull).

TABLE 44B

IRQ SELECTED	CONFIG REG B BITS 5:3
15	110
14	101
11	100
10	011
9	010
7	001
5	111
All Others	000

TABLE 44C

DMA SELECTED	CONFIG REG B BITS 2:0
3	011
2	010
1	001
All Others	000

OPERATION

Mode Switching/Software Control

Software will execute P1284 negotiation and all operation prior to a data transfer phase under programmed I/O control (mode 000 or 001). Hardware provides an automatic control line handshake, moving data between the FIFO and the ECP port only in the data transfer phase (modes 011 or 010).

Setting the mode to 011 or 010 will cause the hardware to initiate data transfer.

If the port is in mode 000 or 001 it may switch to any other mode. If the port is not in mode 000 or 001 it can only be switched into mode 000 or 001. The direction can only be changed in mode 001.

Once in an extended forward mode the software should wait for the FIFO to be empty before switching back to mode 000 or 001. In this case all control signals will be deasserted before the mode switch. In an ecp reverse mode the software waits for all the data to be read from the FIFO before changing back to mode 000 or 001. Since the automatic hardware ecp reverse handshake only cares about the state of the FIFO it may have acquired extra data which will be discarded. It may in fact be in the middle of a transfer when the mode is changed back to 000 or 001. In this case the port will deassert nAutoFd independent of the state of the transfer. The design shall not cause glitches on the handshake signals if the software meets the constraints above.

ECP Operation

Prior to ECP operation the Host must negotiate on the parallel port to determine if the peripheral supports the ECP protocol. This is a somewhat complex negotiation carried out under program control in mode 000.

After negotiation, it is necessary to initialize some of the port bits. The following are required:

- Set Direction = 0, enabling the drivers.
- Set strobe = 0, causing the nStrobe signal to default to the deasserted state.

- Set autoFd = 0, causing the nAutoFd signal to default to the deasserted state.
- Set mode = 011 (ECP Mode)

ECP address/RLE bytes or data bytes may be sent automatically by writing the ecpAFifo or ecpDFifo respectively.

Note that all FIFO data transfers are byte wide and byte aligned. Address/RLE transfers are byte-wide and only allowed in the forward direction.

The host may switch directions by first switching to mode = 001, negotiating for the forward or reverse channel, setting direction to 1 or 0, then setting mode = 011. When direction is 1 the hardware shall handshake for each ECP read data byte and attempt to fill the FIFO. Bytes may then be read from the ecpDFifo as long as it is not empty.

ECP transfers may also be accomplished (albeit slowly) by handshaking individual bytes under program control in mode = 001, or 000.

Termination from ECP Mode

Termination from ECP Mode is similar to the termination from Nibble/Byte Modes. The host is permitted to terminate from ECP Mode only in specific well-defined states. The termination can only be executed while the bus is in the forward direction. To terminate while the channel is in the reverse direction, it must first be transitioned into the forward direction.

Command/Data

ECP Mode supports two advanced features to improve the effectiveness of the protocol for some applications. The features are implemented by allowing the transfer of normal 8 bit data or 8 bit commands.

When in the forward direction, normal data is transferred when HostAck is high and an 8 bit command is transferred when HostAck is low.

The most significant bit of the command indicates whether it is a run-length count (for compression) or a channel address.

When in the reverse direction, normal data is transferred when PeriphAck is high and an 8 bit command is transferred when PeriphAck is low. The most significant bit of the command is always zero. Reverse channel addresses are seldom used and may not be supported in hardware.

**Table 45 –
Forward Channel Commands (HostAck Low)
Reverse Channel Commands (PeriphAck Low)**

D7	D[6:0]
0	Run-Length Count (0-127) (mode 0011 0X00 only)
1	Channel Address (0-127)

Data Compression

The ECP port supports run length encoded (RLE) decompression in hardware and can transfer compressed data to a peripheral. Run length encoded (RLE) compression in hardware is not supported. To transfer compressed data in ECP mode, the compression count is written to the ecpAFifo and the data byte is written to the ecpDFifo.

Compression is accomplished by counting identical bytes and transmitting an RLE byte that indicates how many times the next byte is to be repeated. Decompression simply intercepts the RLE byte and repeats the following byte the specified number of times. When a run-length count is received from a peripheral, the

subsequent data byte is replicated the specified number of times. A run-length count of zero specifies that only one byte of data is represented by the next data byte, whereas a run-length count of 127 indicates that the next byte should be expanded to 128 bytes. To prevent data expansion, however, run-length counts of zero should be avoided.

Pin Definition

The drivers for nStrobe, nAutoFd, nIntr and nSelectIn are open-collector in mode 000 and are push-pull in all other modes.

ISA Connections

The interface can never stall causing the host to hang. The width of data transfers is strictly controlled on an I/O address basis per this specification. All FIFO-DMA transfers are byte wide, byte aligned and end on a byte boundary. (The PWord value can be obtained by reading Configuration Register A, cnfgA, described in the next section). Single byte wide transfers are always possible with standard or PS/2 mode using program control of the control signals.

Interrupts

The interrupts are enabled by serviceIntr in the ecr register.

serviceIntr = 1 Disables the DMA and all of the service interrupts.

serviceIntr = 0 Enables the selected interrupt condition. If the interrupting condition is valid, then the interrupt is generated immediately when this bit is changed from a 1 to a 0. This can occur during Programmed I/O if the number of bytes removed or added from/to the FIFO does not cross the threshold.

The interrupt generated is ISA friendly in that it must pulse the interrupt line low, allowing for

interrupt sharing. After a brief pulse low following the interrupt event, the interrupt line is tri-stated so that other interrupts may assert.

An interrupt is generated when:

1. For DMA transfers: When `serviceIntr` is 0, `dmaEn` is 1 and the DMA TC is received.
2. For Programmed I/O:
 - a. When `serviceIntr` is 0, `dmaEn` is 0, `direction` is 0 and there are `writeIntrThreshold` or more free bytes in the FIFO. Also, an interrupt is generated when `serviceIntr` is cleared to 0 whenever there are `writeIntrThreshold` or more free bytes in the FIFO.
 - b.(1) When `serviceIntr` is 0, `dmaEn` is 0, `direction` is 1 and there are `readIntrThreshold` or more bytes in the FIFO. Also, an interrupt is generated when `serviceIntr` is cleared to 0 whenever there are `readIntrThreshold` or more bytes in the FIFO.
3. When `nErrIntrEn` is 0 and `nFault` transitions from high to low or when `nErrIntrEn` is set from 1 to 0 and `nFault` is asserted.
4. When `ackIntEn` is 1 and the `nAck` signal transitions from a low to a high.

FIFO Operation

The FIFO threshold is set in the chip configuration registers. All data transfers to or from the parallel port can proceed in DMA or Programmed I/O (non-DMA) mode as indicated by the selected mode. The FIFO is used by selecting the Parallel Port FIFO mode or ECP Parallel Port Mode. (FIFO test mode will be addressed separately.) After a reset, the FIFO is disabled. Each data byte is transferred by a Programmed I/O cycle or PDRQ depending on the selection of DMA or Programmed I/O mode.

The following paragraphs detail the operation of the FIFO flow control. In these descriptions, `<threshold>` ranges from 1 to 16. The parameter

FIFOTHR, which the user programs, is one less and ranges from 0 to 15.

A low threshold value (i.e. 2) results in longer periods of time between service requests, but requires faster servicing of the request for both read and write cases. The host must be very responsive to the service request. This is the desired case for use with a "fast" system. A high value of threshold (i.e. 12) is used with a "sluggish" system by affording a long latency period after a service request, but results in more frequent service requests.

DMA TRANSFERS

DMA transfers are always to or from the `ecpDFifo`, `tFifo` or `CFifo`. DMA utilizes the standard PC DMA services. To use the DMA transfers, the host first sets up the direction and state as in the programmed I/O case. Then it programs the DMA controller in the host with the desired count and memory address. Lastly it sets `dmaEn` to 1 and `serviceIntr` to 0. The ECP requests DMA transfers from the host by activating the PDRQ pin. The DMA will empty or fill the FIFO using the appropriate direction and mode. When the terminal count in the DMA controller is reached, an interrupt is generated and `serviceIntr` is asserted, disabling DMA. In order to prevent possible blocking of refresh requests `dReq` shall not be asserted for more than 32 DMA cycles in a row. The FIFO is enabled directly by asserting `nPDACK` and addresses need not be valid. `PINTR` is generated when a TC is received. `PDRQ` must not be asserted for more than 32 DMA cycles in a row. After the 32nd cycle, `PDRQ` must be kept unasserted until `nPDACK` is deasserted for a minimum of 350nsec. (Note: The only way to properly terminate DMA transfers is with a TC.)

DMA may be disabled in the middle of a transfer by first disabling the host DMA controller. Then setting `serviceIntr` to 1, followed by setting `dmaEn` to 0, and waiting for the FIFO to become empty or full. Restarting the DMA is accomplished by enabling DMA in the host, setting `dmaEn` to 1, followed by setting `serviceIntr` to 0.

DMA Mode - Transfers from the FIFO to the Host

(Note: In the reverse mode, the peripheral may not continue to fill the FIFO if it runs out of data to transfer, even if the chip continues to request more data from the peripheral.)

The ECP activates the PDRQ pin whenever there is data in the FIFO. The DMA controller must respond to the request by reading data from the FIFO. The ECP will deactivate the PDRQ pin when the FIFO becomes empty or when the TC becomes true (qualified by nPDACK), indicating that no more data is required. PDRQ goes inactive after nPDACK goes active for the last byte of a data transfer (or on the active edge of nIOR, on the last byte, if no edge is present on nPDACK). If PDRQ goes inactive due to the FIFO going empty, then PDRQ is active again as soon as there is one byte in the FIFO. If PDRQ goes inactive due to the TC, then PDRQ is active again when there is one byte in the FIFO, and serviceIntr has been re-enabled. (Note: A data underrun may occur if PDRQ is not removed in time to prevent an unwanted cycle).

Programmed I/O Mode or Non-DMA Mode

The ECP or parallel port FIFOs may also be operated using interrupt driven programmed I/O. Software can determine the writeIntrThreshold, readIntrThreshold, and FIFO depth by accessing the FIFO in Test Mode.

Programmed I/O transfers are to the ecpDFifo at 400H and ecpAFifo at 000H or from the ecpDFifo located at 400H, or to/from the tFifo at 400H. To use the programmed I/O transfers, the host first sets up the direction and state, sets dmaEn to 0 and serviceIntr to 0.

The ECP requests programmed I/O transfers from the host by activating the PINTR pin. The programmed I/O will empty or fill the FIFO using the appropriate direction and mode.

Note: A threshold of 16 is equivalent to a threshold of 15. These two cases are treated the same.

Programmed I/O - Transfers from the FIFO to the Host

In the reverse direction an interrupt occurs when serviceIntr is 0 and readIntrThreshold bytes are available in the FIFO. If at this time the FIFO is full it can be emptied completely in a single burst, otherwise readIntrThreshold bytes may be read from the FIFO in a single burst.

$\text{readIntrThreshold} = (16 - \langle \text{threshold} \rangle) \text{ data bytes in FIFO}$

An interrupt is generated when serviceIntr is 0 and the number of bytes in the FIFO is greater than or equal to $(16 - \langle \text{threshold} \rangle)$. (If the threshold = 12, then the interrupt is set whenever there are 4-16 bytes in the FIFO). The PINT pin can be used for interrupt-driven systems. The host must respond to the request by reading data from the FIFO. This process is repeated until the last byte is transferred out of the FIFO. If at this time the FIFO is full, it can be completely emptied in a single burst, otherwise a minimum of $(16 - \langle \text{threshold} \rangle)$ bytes may be read from the FIFO in a single burst.

Programmed I/O - Transfers from the Host to the FIFO

In the forward direction an interrupt occurs when serviceIntr is 0 and there are writeIntrThreshold or more bytes free in the FIFO. At this time if the FIFO is empty it can be filled with a single burst before the empty bit needs to be re-read. Otherwise it may be filled with writeIntrThreshold bytes.

$\text{writeIntrThreshold} = (16 - \langle \text{threshold} \rangle) \text{ free bytes in FIFO}$

An interrupt is generated when servicelntr is 0 and the number of bytes in the FIFO is less than or equal to <threshold>. (If the threshold = 12, then the interrupt is set whenever there are 12 or less bytes of data in the FIFO.) The PINT pin can be used for interrupt-driven systems. The host must respond to the request by writing data to the FIFO.

If at this time the FIFO is empty, it can be completely filled in a single burst, otherwise a minimum of (16-<threshold>) bytes may be written to the FIFO in a single burst. This process is repeated until the last byte is transferred into the FIFO.

PARALLEL PORT FLOPPY DISK CONTROLLER

The Floppy Disk Control signals are available optionally on the parallel port pins. When this mode is selected, the parallel port is not available. There are two modes of operation, PPF1 and PPF2. These modes can be selected in the Parallel Port Mode Register, as defined in the Parallel Port Mode Register, Logical Device 3, at 0xF1. PPF1 has only drive 1 on the parallel port pins; PPF2 has drive 0 and 1 on the parallel port pins.

1. Control Register read as "cable not connected" STROBE, AUTOFD and SLC = 0 and nINIT = 1
3. Status Register reads: nBUSY = 0, PE = 0, SLCT = 0, nACK = 1, nERR = 1

The following FDC pins are all in the high impedance state when the PPFDC is actually selected by the drive select register:

When the PPFDC is selected the following pins are set as follows:

1. nWDATA, DENSEL, nHDSEL, nWGATE, nDIR, nSTEP, nDS1, nDS0, nMTR0, nMTR1.
2. If PPFdx is selected, then the parallel port can not be used as a parallel port until "Normal" mode is selected.

1. nPDACK: high-Z
2. PDRQ: not ECP = high-Z, ECP & dmaEn = 0, ECP & not dmaEn = high-Z
3. PINTR: not active, this is hi-Z or Low depending on settings.

The FDC signals are muxed onto the Parallel Port pins as shown in TABLE 47.

Note: nPDACK, PDRQ and PINTR refer to the nDACK, DRQ and IRQ chosen for the parallel port.

For ACPI compliance the FDD pins that are multiplexed onto the Parallel Port function independently of the state of the Parallel Port controller. For example, if the FDC is enabled onto the Parallel Port the multiplexed FDD interface functions normally regardless of the Parallel Port Power control, CR22.3. TABLE 46 illustrates this functionality.

The following parallel port pins are read as follows by a read of the parallel port register:

1. Data Register (read) = last Data Register (write)

TABLE 46 - PARALLEL PORT FDD CONTROL

PARALLEL PORT POWER	PARALLEL PORT FDC CONTROL		PARALLEL PORT FDC STATE	PARALLEL PORT STATE
	LD3:CRF1.1	LD3:CRF1.0		
CR22.3				
1	0	0	OFF	ON
0	0	0	OFF	OFF
X	1	X	ON	OFF (NOTE ¹)
	X	1		

NOTE¹: The Parallel Port Control register reads as “Cable Not Connected” when the Parallel Port FDC is enabled; i.e., STROBE = AUTOFD = SLC = 0 and nINIT = 1.

TABLE 47 - FDC PARALLEL PORT PINS

SPP MODE	PIN DIRECTION	FDC MODE	PIN DIRECTION
nSTROBE	I/O	(nDS0)	I/(O) Note1
PD0	I/O	nINDEX	I
PD1	I/O	nTRK0	I
PD2	I/O	nWP	I
PD3	I/O	nRDATA	I
PD4	I/O	nDSKCHG	I
PD5	I/O	-	-
PD6	I/O	(nMTR0)	I/(O) Note1
PD7	I/O	-	-
nACK	I	nDS1	O
BUSY	I	nMTR1	O
PE	I	nWDATA	O
SLCT	I	nWGATE	O
nALF	I/O	DRV DEN0	O
nERROR	I	nHDSEL	O
nINIT	I/O	nDIR	O
nSLCTIN	I/O	nSTEP	O

Note 1: These pins are outputs in mode PPF2, inputs in mode PPF1.

Refer to Force Write Protect in the Floppy Disk Controller section for information on the Floppy disk Controller Force Write Protect function.

POWER MANAGEMENT

Power management capabilities are provided for the following logical devices: floppy disk, UART 1, UART 2 and the parallel port. For each logical device, two types of power management are provided; direct powerdown and auto powerdown.

FDC Power Management

Direct power management is controlled by CR22. Refer to CR22 for more information.

Auto Power Management is enabled by CR23-B0. When set, this bit allows FDC to enter powerdown when all of the following conditions have been met:

1. The motor enable pins of register 3F2H are inactive (zero).
2. The part must be idle; MSR=80H and INT = 0 (INT may be high even if MSR = 80H due to polling interrupts).
3. The head unload timer must have expired.

4. The Auto powerdown timer (10msec) must have timed out.

An internal timer is initiated as soon as the auto powerdown command is enabled. The part is then powered down when all the conditions are met.

Disabling the auto powerdown mode cancels the timer and holds the FDC block out of auto powerdown.

DSR From Powerdown

If DSR powerdown is used when the part is in auto powerdown, the DSR powerdown will override the auto powerdown. However, when the part is awakened from DSR powerdown, the auto powerdown will once again become effective.

Wake Up From Auto Powerdown

If the part enters the powerdown state through the auto powerdown mode, then the part can be awakened by reset or by appropriate access to certain registers.

If a hardware or software reset is used then the part will go through the normal reset sequence. If the access is through the selected registers, then the FDC resumes operation as though it was never in powerdown. Besides activating the RESET pin or one of the software reset bits in the DOR or DSR, the following register accesses will wake up the part:

1. Enabling any one of the motor enable bits in the DOR register (reading the DOR does not awaken the part).
2. A read from the MSR register.
3. A read or write to the Data register.

Once awake, the FDC will reinitiate the auto powerdown timer for 10 ms. The part will powerdown again when all the powerdown conditions are satisfied.

Register Behavior

TABLE 48 illustrates the AT and PS/2 (including Model 30) configuration registers available and the type of access permitted. In order to maintain software transparency, access to all the registers must be maintained. As TABLE 48 shows, two sets of registers are distinguished based on whether their access results in the part remaining in powerdown state or exiting it.

Access to all other registers is possible without awakening the part. These registers can be accessed during powerdown without changing the status of the part. A read from these registers will reflect the true status as shown in the register description in the FDC description. A write to the part will result in the part retaining the data and subsequently reflecting it when the part awakens. Accessing the part during powerdown may cause an increase in the power consumption by the part. The part will revert back to its low power mode when the access has been completed.

Pin Behavior

This chip is specifically designed for systems in which power conservation is a primary concern. This makes the behavior of the pins during powerdown very important.

The pins can be divided into two major categories: system interface and floppy disk drive interface. The floppy disk drive pins are disabled so that no power will be drawn through the part as a result of any voltage applied to the pin within the part's power supply range. Most of the system interface pins are left active to monitor system accesses that may wake up the part.

System Interface Pins

TABLE 49 gives the state of the system interface pins in the powerdown state. Pins unaffected by the powerdown are labeled "Unchanged". Input pins are "Disabled" to prevent them from causing currents internal to the chip when they have indeterminate input values.

TABLE 48 - PC/AT AND PS/2 AVAILABLE REGISTERS

BASE + ADDRESS	AVAILABLE REGISTERS		
	PC-AT	PS/2 (MODEL 30)	ACCESS PERMITTED
Access to these registers DOES NOT wake up the part			
00H	----	SRA	R
01H	----	SRB	R
02H	DOR (1)	DOR (1)	R/W
03H	---	---	---
04H	DSR (1)	DSR (1)	W
06H	---	---	---
07H	DIR	DIR	R
07H	CCR	CCR	W
Access to these registers wakes up the part			
04H	MSR	MSR	R
05H	Data	Data	R/W

Note 1: Writing to the DOR or DSR does not wake up the part, however, writing any of the motor enable bits or doing a software reset (via DOR or DSR reset bits) will wake up the part.

TABLE 49 - STATE OF SYSTEM PINS IN AUTO POWERDOWN

SYSTEM PINS	STATE IN AUTO POWERDOWN
INPUT PINS	
nIOR	Unchanged
nIOW	Unchanged
SA[0:9]	Unchanged
SD[0:7]	Unchanged
RESET_DRV	Unchanged
DACKx	Unchanged
TC	Unchanged
OUTPUT PINS	
IRQx	Unchanged (low)
SD[0:7]	Unchanged
DRQx	Unchanged (low)

FDD Interface Pins

All pins in the FDD interface which can be connected directly to the floppy disk drive itself are either DISABLED or TRISTATED.

Pins used for local logic control or part programming are unaffected. TABLE 50 depicts the state of the floppy disk drive interface pins in the powerdown state.

TABLE 50 - STATE OF FLOPPY DISK DRIVE INTERFACE PINS IN POWERDOWN

FDD PINS	STATE IN AUTO POWERDOWN
INPUT PINS	
nRDATA	Input
nWPROT	Input
nTR0	Input
nINDEX	Input
nDSKCHG	Input
OUTPUT PINS	
nMTR0	Tristated
nDS0	Tristated
nDIR	Active
nSTEP	Active
nWDATA	Tristated
nWGATE	Tristated
nHDSEL	Active
DRV DEN[0:1]	Active

UART Power Management

Direct power management is controlled by CR22. Refer to CR22 for more information.

Auto Power Management is enabled by CR23-B4 and B5. When set, these bits allow the following auto power management operations:

1. The transmitter enters auto powerdown when the transmit buffer and shift register are empty.
2. The receiver enters powerdown when the following conditions are all met:
 - A. Receive FIFO is empty
 - B. The receiver is waiting for a start bit.

Note: While in powerdown the Ring Indicator interrupt is still valid and transitions when the RI input changes.

Exit Auto Powerdown

The transmitter exits powerdown on a write to the XMIT buffer. The receiver exits auto powerdown when RXDx changes state.

Parallel Port

Direct power management is controlled by CR22. Refer to CR22 for more information.

Auto Power Management is enabled by CR23-B3. When set, this bit allows the ECP or EPP logical parallel port blocks to be placed into powerdown when not being used.

The EPP logic is in powerdown under any of the following conditions:

1. EPP is not enabled in the configuration registers.
2. EPP is not selected through ecr while in ECP mode.

The ECP logic is in powerdown under any of the following conditions:

1. ECP is not enabled in the configuration registers.
2. SPP, PS/2 Parallel port or EPP mode is selected through ecr while in ECP mode.

Exit Auto Powerdown

The parallel port logic can change powerdown modes when the ECP mode is changed through the ecr register or when the parallel port mode is changed through the configuration registers.

V_{BAT} Support

This chip requires a (TBD) MicroAmp battery supply (V_{BAT}) to provide battery backed up registers. These registers retain the contents of the general purpose registers and wake-up event registers. The RTC and CMOS registers are also battery backed up. Note: The configuration of the Consumer IR wake-up functionality is not battery backed-up.

V_{TR} Support

The FDC37B78x requires a 25 mA trickle supply (V_{TR}) to provide sleep current for the programmable wake-up events in the Soft Power Management logic, SCI, PME and SMI interfaces when V_{CC} is removed. If the FDC37B78x is not intended to provide wake-up capabilities on standby current, V_{TR} can be connected to V_{CC}. V_{TR} powers the Consumer IR receiver, IR interface, the CIR run-time registers, the PME configuration registers, and the PME interface. The V_{TR} pin generates a V_{TR} Power-on-Reset signal to initialize certain components. All wakeup event registers and related logic are battery backed-up to retain the configuration of the wakeup events upon a power loss (i.e., V_{CC} = 0 V and V_{TR} = 0 V). These registers are reset on a V_{BAT} POR.

Internal PWRGOOD

An internal PWRGOOD logical control is included to minimize the effects of pin-state uncertainty in the host interface as V_{CC} cycles on and off. When the internal PWRGOOD signal is “1” (active), V_{CC} is $> 4V$, and the FDC37B78x host interface is active. When the internal PWRGOOD signal is “0” (inactive), V_{CC} is $\leq 4V$, and the FDC37B78x host interface is inactive; that is, ISA bus reads and writes will not be decoded.

The FDC37B78x device pins nPME, KCLK, MCLK, IRRX, nRI1, nRI2, RXD1, RXD2, nRING, Button_In and GP53 are part of the PME interface and remain active when the internal PWRGOOD signal has gone inactive, provided V_{TR} is powered. In addition, the nPowerOn and CLK32OUT pins remain active when the internal PWRGOOD is inactive and V_{TR} is powered. When the internal PWRGOOD is inactive, and V_{TR} is powered, the GPIOs (excluding GP53) become tri-state (input) and are able to generate wake-up events. The internal PWRGOOD signal is also used to determine the clock source for the CirCC CIR and to disable the IR Half Duplex Timeout.

Note: If V_{TR} is to be used for programmable wake-up events when V_{CC} is removed, V_{TR} must be at its full minimum potential at least 10 μs before V_{CC} begins a power-on cycle. When V_{TR} and V_{CC} are fully powered, the potential difference between the two supplies must not exceed 500mV.

CIRCC PLL Power Control

The FDC37B78x uses the 32.768 kHz RTC clock and a clock multiplier (PLL) to drive the CirCC Wakeup function when V_{CC} has been removed. The CIR PLL Power bit, located in the Sleep/Wake Configuration Register, is used to enable (power-up) the 32.768 kHz clock PLL. When the CIR PLL Power bit is set to “1” (active), the 32.768 kHz clock PLL is running and can replace the 14.318 MHz clock source for the CIR Wake Event, depending upon the state of the internal PWRGOOD signal (TABLE 51). When the CIR PLL Power bit is reset to “0” (inactive/default), the 32.768 kHz clock PLL is unpowered.

TABLE 51 - FDC37B78x PLL CONTROLS AND SELECTS

PLL CONTROL BIT (CR24.1)	CIR PLL POWER BIT	INTERNAL PWRGOOD	DESCRIPTION
1	X	X	All PLLs Powered Down
0	0	0	
0	0	1	32KHz PLL Unpowered, Not Selected, 14MHz PLL Powered, Selected.
0	1	0	32KHz PLL Powered, Selected, 14MHz PLL Unpowered, Not Selected.
0	1	1	32KHz PLL Powered, Not Selected, 14MHz PLL Powered, Selected.

32.768 kHz Standby Clock Output

The FDC37B78x provides a 32.768 kHz trickle clock output pin. This output is active as long as V_{TR} is present.

SERIAL INTERRUPTS

The FDC37B78x will support the serial interrupt to transmit interrupt information to the host system. The serial interrupt scheme adheres to the Serial IRQ Specification for PCI Systems, Version 6.0.

Timing Diagrams For IRQSER Cycle

PCICLK = 33Mhz_IN pin
 IRQSER = SIRQ pin

A) Start Frame timing with source sampled a low pulse on IRQ1

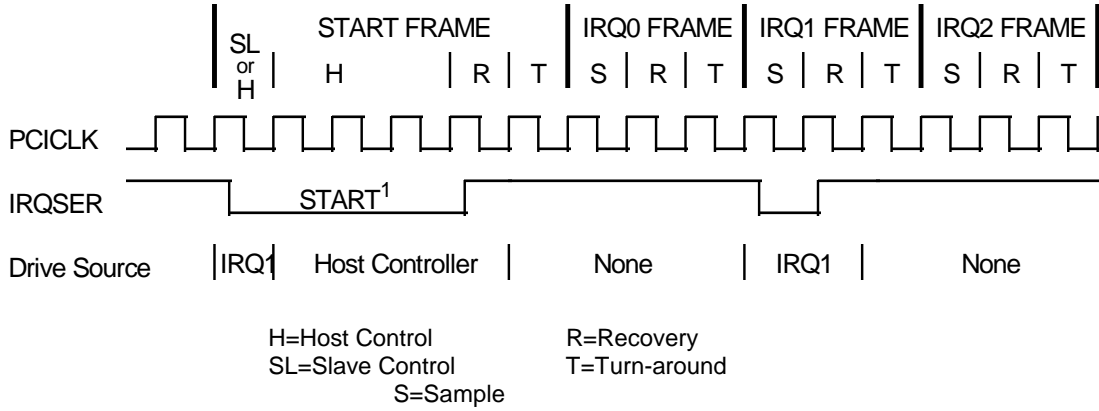

1) Start Frame pulse can be 4-8 clocks wide.

B) Stop Frame Timing with Host using 17 IRQSER sampling period

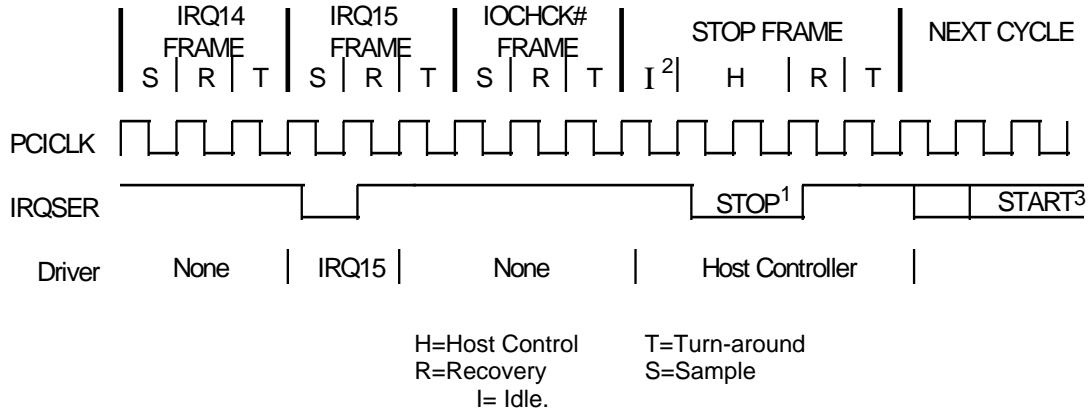

- 1) Stop pulse is 2 clocks wide for Quiet mode, 3 clocks wide for Continuous mode.
- 2) There may be none, one or more Idle states during the Stop Frame.
- 3) The next IRQSER cycle's Start Frame pulse may or may not start immediately after the turn-around clock of the Stop Frame.

IRQSER Cycle Control

There are two modes of operation for the IRQSER Start Frame.

1) **Quiet (Active) Mode:** Any device may initiate a Start Frame by driving the IRQSER low for one clock, while the IRQSER is Idle. After driving low for one clock the IRQSER must immediately be tri-stated without at any time driving high. A Start Frame may not be initiated while the IRQSER is Active. The IRQSER is Idle between Stop and Start Frames. The IRQSER is Active between Start and Stop Frames. This mode of operation allows the IRQSER to be Idle when there are no IRQ/Data transitions which should be most of the time.

Once a Start Frame has been initiated the Host Controller will take over driving the IRQSER low in the next clock and will continue driving the IRQSER low for a programmable period of three to seven clocks. This makes a total low pulse width of four to eight clocks. Finally, the Host Controller will drive the IRQSER back high for one clock, then tri-state.

Any IRQSER Device (i.e., The FDC37B78x) which detects any transition on an IRQ/Data line for which it is responsible must initiate a Start Frame in order to update the Host Controller unless the IRQSER is already in an IRQSER Cycle and the IRQ/Data transition can be delivered in that IRQSER Cycle.

2) **Continuous (Idle) Mode:** Only the Host controller can initiate a Start Frame to update IRQ/Data line information. All other IRQSER agents become passive and may not initiate a Start Frame. IRQSER will be driven low for four to eight clocks by Host Controller. This mode has two functions. It can be used to stop or idle the IRQSER or the Host Controller can operate IRQSER in a continuous mode by initiating a Start Frame at the end of every Stop Frame.

An IRQSER mode transition can only occur during the Stop Frame. **Upon reset, IRQSER bus is defaulted to Continuous mode, therefore only the Host controller can initiate the first Start Frame. Slaves must continuously sample the Stop Frames pulse width to determine the next IRQSER Cycle's mode.**

IRQSER Data Frame

Once a Start Frame has been initiated, the FDC37B78x will watch for the rising edge of the Start Pulse and start counting IRQ/Data Frames from there. Each IRQ/Data Frame is three clocks: Sample phase, Recovery phase, and Turn-around phase. During the Sample phase the FDC37B78x must drive the IRQSER (SIRQ pin) low, if and only if, its last detected IRQ/Data value was low. If its detected IRQ/Data value is high, IRQSER must be left tri-stated. During the Recovery phase the FDC37B78x must drive the SERIRQ high, if and only if, it had driven the IRQSER low during the previous Sample Phase.

During the Turn-around Phase the FDC37B78x must tri-state the SERIRQ. The FDC37B78x will drive the IRQSER line low at the appropriate sample point if its associated IRQ/Data line is low, regardless of which device initiated the Start Frame.

The Sample Phase for each IRQ/Data follows the low to high transition of the Start Frame pulse by a number of clocks equal to the IRQ/Data Frame times three, minus one. (e.g. The IRQ5 Sample clock is the sixth IRQ/Data Frame, $(6 \times 3) - 1 = 17$ th clock after the rising edge of the Start Pulse).

IRQSER Sampling Periods

IRQSER PERIOD	SIGNAL SAMPLED	# OF CLOCKS PAST START
1	Not Used	2
2	IRQ1	5
3	nSMI/IRQ2	8
4	IRQ3	11
5	IRQ4	14
6	IRQ5	17
7	IRQ6	20
8	IRQ7	23
9	IRQ8	26
10	IRQ9	29
11	IRQ10	32
12	IRQ11	35
13	IRQ12	38
14	IRQ13	41
15	IRQ14	44
16	IRQ15	47

Note: It is the responsibility of the software to ensure that two IRQ's are not set to the same IRQ number.

The SIRQ data frame will now support IRQ2 from a logical device, previously IRQSER Period 3 was reserved for use by the System Management Interrupt (nSMI). When using Period 3 for IRQ2 the user should mask off the SMI via the SMI Enable Register. Likewise, when using Period 3 for nSMI the user should not configure any logical devices as using IRQ2.

IRQSER Period 14 is used to transfer IRQ13. Logical devices 0 (FDC), 3 (Par Port), 4 (Ser Port 1), 5 (Ser Port 2), 6 (RTC), and 7 (KBD) shall have IRQ13 as a choice for their primary interrupt.

Note: When Serial IRQs are used, the RTC IRQ, nSCI and nSMI may be output on one of their respective pin options. See the IRQ MUX Configuration Register.

Stop Cycle Control

Once all IRQ/Data Frames have completed the Host Controller will terminate IRQSER activity by initiating a Stop Frame. Only the Host Controller can initiate the Stop Frame. A Stop Frame is indicated when the IRQSER is low for two or three clocks. If the Stop Frame's low time is two clocks then the next IRQSER Cycle's sampled mode is the Quiet mode; and any IRQSER device may initiate a Start Frame in the second clock or more after the rising edge of the Stop Frame's pulse. If the Stop Frame's low time is three clocks then the next IRQSER Cycle's sampled mode is the Continuous mode; and only the Host Controller may initiate a Start Frame in the second clock or more after the rising edge of the Stop Frame's pulse.

Latency

Latency for IRQ/Data updates over the IRQSER bus in bridge-less systems with the minimum IRQ/Data Frames of seventeen, will range up to 96 clocks (3.84µS with a 25MHz PCI Bus or 2.88µS with a 33MHz PCI Bus). If one or more PCI to PCI Bridge is added to a system, the latency for IRQ/Data updates from the secondary or tertiary buses will be a few clocks longer for synchronous buses, and approximately double for asynchronous buses.

EOI/ISR Read Latency

Any serialized IRQ scheme has a potential implementation issue related to IRQ latency. IRQ latency could cause an EOI or ISR Read to precede an IRQ transition that it should have

followed. This could cause a system fault. The host interrupt controller is responsible for ensuring that these latency issues are mitigated. The recommended solution is to delay EOIs and ISR Reads to the interrupt controller by the same amount as the IRQSER Cycle latency in order to ensure that these events do not occur out of order.

AC/DC Specification Issue

All IRQSER agents must drive / sample IRQSER synchronously related to the rising edge of PCI bus clock. IRQSER (SIRQ) pin uses the electrical specification of PCI bus. Electrical parameters will follow PCI spec. section 4, sustained tri-state.

Reset and Initialization

The IRQSER bus uses RESET_DRV as its reset signal. The IRQSER pin is tri-stated by all agents while RESET_DRV is active. With reset, IRQSER Slaves are put into the (continuous) IDLE mode. The Host Controller is responsible for starting the initial IRQSER Cycle to collect system's IRQ/Data default values. The system then follows with the Continuous/Quiet mode protocol (Stop Frame pulse width) for subsequent IRQSER Cycles. It is Host Controller's responsibility to provide the default values to 8259's and other system logic before the first IRQSER Cycle is performed. For IRQSER system suspend, insertion, or removal application, the Host controller should be programmed into Continuous (IDLE) mode first. This is to guarantee IRQSER bus is in IDLE state before the system configuration changes.

BIOS BUFFER

The chip contains one 245 type buffer that can be used for a BIOS Buffer. If the BIOS buffer is not used, then nROMCS must be tied high or pulled up to Vcc with a resistor so as not to interfere with the boot ROM. This function allows data

transmission from the RD bus to the SD bus or from the SD bus to the RD bus. The direction of the transfer is controlled by nROMOE. The enable input, nROMCS, can be used to disable the transfer and isolate the buses.

nROMCS	nROMOE	DESCRIPTION
L	L	RD[0:7] data to SD[0:7] bus
L	H	SD[0:7] data to RD[0:7]
H	X	Isolation

RD Bus Functionality

The following cases described below illustrate the use of the RD Bus.

Case 1: nROMCS and nROMOE as original function. The RD bus can be used as the RD bus or one or more RD pins can be programmed as alternate function. These alternate functions behave as follows: if in RD to SD mode, any value on RDx will appear on SDx; if in SD to RD mode, SDx will not appear on RDx, RDx gets the alternate function value. Note: In this case, nROMCS=0, nROMOE=1.

Case 2: nROMOE as GPIO function. (nROMOE internally tied to ground). In this case, the RD bus is a unidirectional bus (read only) controlled by nROMCS. If nROMCS = 0, the values on RD0-7

appear on SD0-7. If nROMCS = 1, the RD bus is disabled, and nothing appears on the SD bus. Note: any RD bus pin can be programmed as an alternate function, however, if nROMCS=0, then anything on the RD bus will appear on the SD bus.

Case 3: nROMCS as GPIO function. (nROMCS internally tied to VDD.) The RD bus floats - cannot use as a bus. Any pin can be programmed as an alternate function.

Case 4: nROMCS and nROMOE as GPIO function. Same as Case 3.

Case 5: Parallel IRQ enabled; RD Bus pins, nROMOE, nROMCS are used as IRQ pins.

GENERAL PURPOSE I/O

The FDC37B78x provides a set of flexible Input/Output control functions to the system designer through the 21 dedicated independently programmable General Purpose I/O pins (GPIO). The GPIO pins can perform simple I/O or can be individually configured to provide predefined alternate functions. VBAT Power-On-Reset configures all GPIO pins as non-inverting inputs.

Description

Each GPIO port requires a 1-bit data register

and an 8-bit configuration control register. The data register for each GPIO port is represented as a bit in one of three 8-bit GPIO DATA Registers, GP1, GP5, and GP6. All of the GPIO registers are located in Logical Device Block No. 8 in the FDC37B78x device configuration space. The GPIO DATA Registers are also optionally available at different addresses when the FDC37B78x is in the Run state. The GPIO ports with their alternate functions and configuration state register addresses are listed in. Note: three bits 5-7 of GP5 are not implemented.

TABLE 52 - GENERAL PURPOSE I/O PORT ASSIGNMENTS

PIN NO. QFP	DEFAULT FUNCTION	ALT. FUNC. 1	ALT. FUNC. 2	ALT. FUNC. 3	DATA REGISTER ⁴ (HEX)	DATA REGISTER BIT NO.	CONFIG. REGISTER ⁴ (HEX)
77	GPIO	nSMI	-	-	GP1 (CRF6)	0	CRE0
78	GPIO	nRING	EETI ¹	-		1	CRE1
79	GPIO	WDT	P17	EETI ¹		2	CRE2
80	GPIO	LED	-	-		3	CRE3
81	GPIO	IRRX2	-	-		4	CRE4
82	GPIO	IRTX2	-	-		5	CRE5
4	GPIO	nMTR1	-	-		6	CRE6
6	GPIO	nDS1	-	-		7	CRE7
39	PCI_CLK	IRQ14	GPIO	-	GP5 (CRF9)	0	CRC8
2	DRV DEN ⁵	GPIO	IRQ8	nSMI		2	CRCA
91	nROMCS ²	IRQ11	GPIO	EETI ¹		3	CRCB
92	nROMOE ²	IRQ12	GPIO	EETI ¹		4	CRCC
83	RD0 ^{2,3}	IRQ1	GPIO	nSMI	GP6 (CRFA)	0	CRD0
84	RD1 ^{2,3}	IRQ3	GPIO	LED		1	CRD1
85	RD2 ^{2,3}	IRQ4	GPIO	nRING		2	CRD2
86	RD3 ^{2,3}	IRQ5	GPIO	WDT		3	CRD3
87	RD4 ^{2,3}	IRQ6	GPIO	P17		4	CRD4
88	RD5 ^{2,3}	IRQ7	GPIO	-		5	CRD5
89	RD6 ^{2,3}	IRQ8	GPIO	-		6	CRD6
90	RD7 ^{2,3}	IRQ10	GPIO	-		7	CRD7

Note 1. Refer to the section on Either Edge Triggered Interrupt Inputs.

Note 2. At power-up, RD0-7, nROMCS and nROMOE function as the XD Bus. To use RD0-7 for alternate functions, nROMCS must stay high until those pins are finished being programmed.

Note 3. These pins cannot be programmed as open drain pins in their original function.

Note 4. The GPIO Data and Configuration Registers are located in Logical Device 8.

Note 5. This pin defaults to its GPIO function. See Configuration Registers.

RUN STATE GPIO DATA REGISTER ACCESS

The GPIO data registers as well as the Watchdog Timer Control, and the Soft Power Enable and Status registers can be accessed by the host

when the chip is in the run state if CR03 Bit[7] = 1. The host uses an Index and Data port to access these registers. The Index and Data port power-on default addresses are 0xEA and 0xEB respectively. In the configuration state the Index

port address may be re-programmed to 0xE0, 0xE2, 0xE4 or 0xEA; the Data port address is automatically set to the Index port address + 1. Upon exiting the configuration state the new Index

and Data port addresses are used to access the GPIO data, Soft Power Status and Enable, and the Watchdog Timer Control registers.

For example, to access the GP1 data register when in the run state, the host should perform an I/O Write of 0x01 to the Index port address (0xEX) to select GP1 and then read or write the Data port (at Index+1) to access the GP1 register. Generally, to access any GPIO data register GPx the host should perform an I/O Write of 0x0X to the Index port address and then access GPX through the Data port. The Soft Power and Watchdog Timer Control registers are accessed similarly.

TABLE 53 - INDEX AND DATA PORTS

PORT NAME	PORT ADDRESS	RUN STATE ACCESS
Index	0xE0, E2, E4, EA	0x01-0x0F
Data	Index address + 1	Access to GP1, Watchdog Timer Control, GP5, GP6, and the Soft Power Status and Enable registers (see TABLE 54).

TABLE 54 - RUN STATE ACCESSIBLE CONFIGURATION REGISTERS

RUN STATE REGISTER ADDRESS (INDEX)	REGISTER (CONFIGURATION STATE ADDRESSING ¹)
0x01	GP1 (L8 - CRF6)
0x03	Watchdog Timer Control (L8 - CRF4)
0x05	GP5 (L8 - CRF9)
0x06	GP6 (L8 - CRFA)
0x08	Soft Power Enable Register 1 (L8-CRB0)
0x09	Soft Power Enable Register 2 (L8-CRB1)
0x0A	Soft Power Status Register 1 (L8-CRB2)
0x0B	Soft Power Status Register 2 (L8-CRB3)

Note 1: These registers can also be accessed through the configuration registers L8 - CRxx, as shown, when the FDC37B78x is in the configuration state.

GPIO CONFIGURATION

Each GPIO port has an 8-bit configuration register that controls the behavior of the pin. The GPIO configuration registers are only accessible when the FDC37B78x is in the Configuration state; more information can be found in the Configuration section of this specification.

Each GPIO port may be configured as either an input or an output. If the pin is configured as an output, it can be programmed as open-drain or push-pull. Inputs and outputs can be configured as non-inverting or inverting and can be programmed to generate an interrupt. GPIO ports can also be configured as a pre-defined alternate function. Bit[0] of each GPIO Configuration Register determines the port direction, bit[1] determines the signal polarity, bits[4:3] select the port function, bit[5] enables the interrupt, and bit[7] determines the output driver type select. The GPIO configuration register Output Type select bit[7] applies to GPIO functions, the Watchdog Timer WDT, the LED and the nSMI Alternate functions. The basic GPIO configuration options are summarized in TABLE 55. For Alternate functions, the pin direction is set and controlled internally, regardless of the state of the GPIO Direction bit[0]. Also, selected Alternate INPUT functions cannot be inverted, regardless of

The state of the GPIO polarity bit[1], except for the EETI function.

The interrupt channel for the group Interrupts is selected by the GP_INT[2:1] configuration registers defined in the FDC37B78x Configuration Register Section. The group interrupts are the "ORed" function of the group interrupt enabled GPIO ports and will represent a standard ISA interrupt (edge high). GPIO Group 1 and 2 Interrupts can generate SMI events, wake-up events through the Soft Power Management logic, and SCI/PME events. See the ACPI, PME and SMI section for details. When the group interrupt is enabled on a GPIO input port, the interrupt circuitry contains a selectable digital debounce filter so that switches or push-buttons may be directly connected to the chip. The debounce filters reject signals with pulse widths $\leq 1\text{ms}$ and are enabled per interrupt group in the GP_INT[2:1] configuration registers.

The state of unconnected GPIO alternate input functions is inactive. For example, if bits[4:3] in LD8 -CRCB are not "00", i.e. nROMCS is not the selected function for GP53, internally the state of nROMCS is inactive, "1".

TABLE 55 - GPIO CONFIGURATION SUMMARY

SELECTED FUNCTION	DIRECTION BIT	POLARITY BIT	GROUP INT. ENABLE BIT	DESCRIPTION
	B0	B1	B5	
GPIO	0	0	0	Pin is a non-inverted output with the Interrupt disabled.
	0	0	1	Pin is a non-inverted output with the Interrupt enabled.
	0	1	0	Pin is an inverted output with the Interrupt disabled.
	0	1	1	Pin is a inverted output with the Interrupt enabled.
	1	0	0	Pin is a non-inverted input with the Interrupt disabled.
	1	0	1	Pin is a non-inverted input with the Interrupt enabled.
	1	1	0	Pin is an inverted input with the Interrupt disabled.
	1	1	1	Pin is a inverted input with the Interrupt enabled.
ALT.	X ¹	0	0	Non-inverted alternate function with Interrupt disabled.
		0	1	Non-inverted alternate function with Interrupt enabled.
		1 ²	0	Alternate OUTPUT functions are inverted, Alternate INPUT functions are non-inverted; Interrupts are disabled.
			1	Alternate OUTPUT functions are inverted, Alternate INPUT functions are non-inverted; Interrupts are enabled.

Note 1. For alternate function selects, the pin direction is set and controlled internally; i.e., regardless of the state of the GPIO configuration register Direction bit.

Note 2. For alternate function selects, INPUT functions cannot be inverted, regardless of the state of the GPIO polarity bit, except for the EETI function.

When a GPIO port is programmed as an input, reading it through the GPIO data register latches either the inverted or non-inverted logic value present at the GPIO pin. Writing to a GPIO port that is programmed as an input has no effect.

When a GPIO port is programmed as an output, the logic value or the inverted logic value that has been written into the GPIO data register is output to the GPIO pin. Reading from a GPIO port that is programmed as an output returns the last value written to the data register.

TABLE 56 - GPIO READ/WRITE BEHAVIOR

HOST OPERATION	GPIO INPUT PORT	GPIO OUTPUT PORT
READ	LATCHED VALUE OF GPIO PIN	LAST WRITE TO GPIO DATA REGISTER
WRITE	NO EFFECT	BIT PLACED IN GPIO DATA REGISTER

8042 KEYBOARD CONTROLLER DESCRIPTION

A Universal Keyboard Controller designed for intelligent keyboard management in desktop computer applications is implemented. The Universal Keyboard Controller uses an 8042 microcontroller CPU core. This section

concentrates on the enhancements to the 8042. For general information about the 8042, refer to the "Hardware Description of the 8042" in the 8-Bit Embedded Controller Handbook.

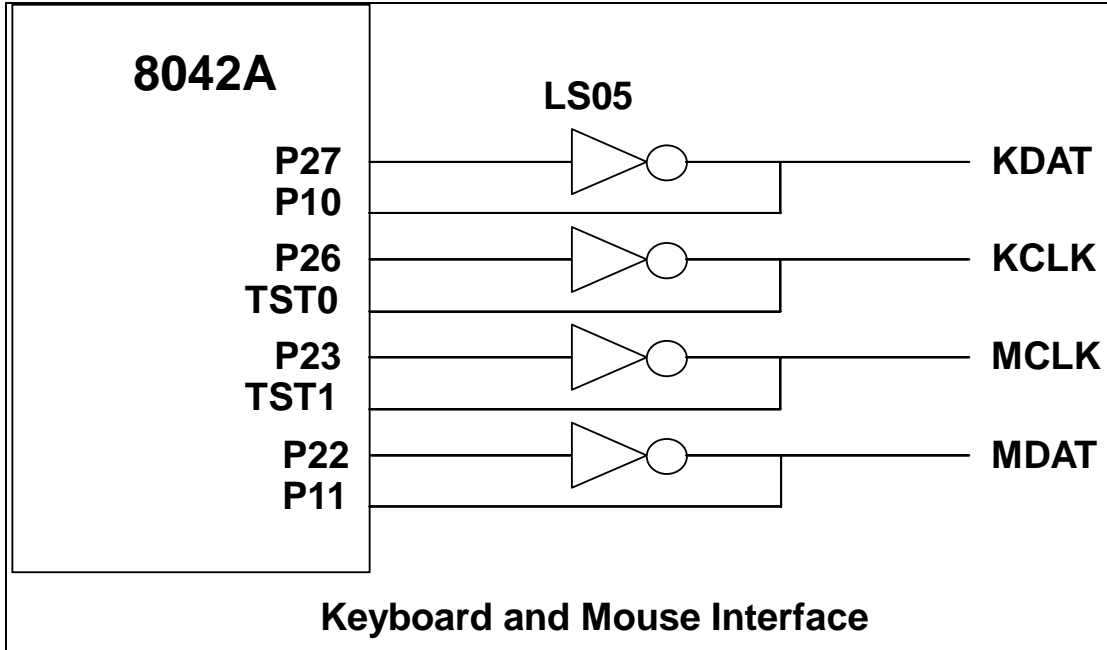

KIRQ is the Keyboard IRQ

MIRQ is the Mouse IRQ

Port 21 is used to create a GATEA20 signal from the FDC37B78x.

KEYBOARD ISA INTERFACE

The FDC37B78x ISA interface is functionally compatible with the 8042-style host interface. It consists of the D0-7 data bus; the nIOR, nIOW

and the Status register, Input Data register, and Output Data register. TABLE 57 shows how the interface decodes the control signals. In addition to the above signals, the host interface includes keyboard and mouse IRQs.

TABLE 57 - ISA I/O ADDRESS MAP

ISA ADDRESS	nIOW	nIOR	BLOCK	FUNCTION (NOTE 1)
0x60	0	1	KDATA	Keyboard Data Write (C/D=0)
	1	0	KDATA	Keyboard Data Read
0x64	0	1	KDCTL	Keyboard Command Write (C/D=1)
	1	0	KDCTL	Keyboard Status Read

Note 1: These registers consist of three separate 8 bit registers. Status, Data/Command Write and Data Read.

Keyboard Data Write

This is an 8 bit write only register. When written, the C/D status bit of the status register is cleared to zero and the IBF bit is set.

Keyboard Command Write

This is an 8 bit write only register. When written, the C/D status bit of the status register is set to one and the IBF bit is set.

Keyboard Data Read

This is an 8 bit read only register. If enabled by "ENABLE FLAGS", when read, the KIRQ output is cleared and the OBF flag in the status register is cleared. If not enabled, the KIRQ and/or AUXOBF1 must be cleared in software.

Keyboard Status Read

This is an 8 bit read only register. Refer to the description of the Status Register for more information.

CPU-to-Host Communication

The FDC37B78x CPU can write to the Output Data register via register DBB. A write to this register automatically sets Bit 0 (OBF) in the Status register. See Table 58.

Table 58 - Host Interface Flags

8042 INSTRUCTION	FLAG
OUT DBB	Set OBF, and, if enabled, the KIRQ output signal goes high

Host-to-CPU Communication

The host system can send both commands and data to the Input Data register. The CPU differentiates between commands and data by reading the value of Bit 3 of the Status register. When bit 3 is "1", the CPU interprets the register contents as a command. When bit 3 is "0", the CPU interprets the register contents as data. During a host write operation, bit 3 is set to "1" if SA2 = 1 or reset to "0" if SA2 = 0.

KIRQ

If "EN FLAGS" has been executed and P24 is set to a one: the OBF flag is gated onto KIRQ. The KIRQ signal can be connected to system interrupt to signify that the FDC37B78x CPU has written to the output data register via "OUT DBB,A". If P24 is set to a zero, KIRQ is forced low. On power-up, after a valid RST pulse has been delivered to the device, KIRQ is reset to 0. KIRQ will normally reflect the status of writes "DBB". (KIRQ is normally selected as IRQ1 for keyboard support.)

If "EN FLAGS" has not been executed: KIRQ can be controlled by writing to P24. Writing a zero to P24 forces KIRQ low; a high forces KIRQ high.

MIRQ

If "EN FLAGS" has been executed and P25 is set to a one:; IBF is inverted and gated onto MIRQ. The MIRQ signal can be connected to system interrupt to signify that the FDC37B78x CPU has read the DBB register.

If "EN FLAGS" has not been executed, MIRQ is controlled by P25, Writing a zero to P25 forces MIRQ low, a high forces MIRQ high. (MIRQ is normally selected as IRQ12 for mouse support).

Gate A20

A general purpose P21 is used as a software controlled Gate A20 or user defined output.

EXTERNAL KEYBOARD AND MOUSE INTERFACE

Industry-standard PC-AT-compatible keyboards employ a two-wire, bidirectional TTL interface for data transmission. Several sources also supply

PS/2 mouse products that employ the same type of interface. To facilitate system expansion, the FDC37B78x provides four signal pins that may be used to implement this interface directly for an external keyboard and mouse.

The FDC37B78x has four high-drive, open-drain output, bidirectional port pins that can be used for external serial interfaces, such as ISA external keyboard and PS/2-type mouse interfaces. They are KCLK, KDAT, MCLK, and MDAT. P26 is inverted and output as KCLK. The KCLK pin is connected to TEST0. P27 is inverted and output as KDAT. The KDAT pin is connected to P10. P23 is inverted and output as MCLK. The MCLK pin is connected to TEST1. P22 is inverted and output as MDAT. The MDAT pin is connected to P11. NOTE: External pull-ups may be required.

KEYBOARD POWER MANAGEMENT

The keyboard provides support for two power-saving modes: soft powerdown mode and hard powerdown mode. In soft powerdown mode, the clock to the ALU is stopped but the timer/counter and interrupts are still active. In hard power down mode the clock to the 8042 is stopped.

Soft Power Down Mode

This mode is entered by executing a HALT instruction. The execution of program code is halted until either RESET is driven active or a data byte is written to the DBBIN register by a master CPU. If this mode is exited using the interrupt, and the IBF interrupt is enabled, then program execution resumes with a CALL to the interrupt routine, otherwise the next instruction is executed. If it is exited using RESET then a normal reset sequence is initiated and program execution starts from program memory location 0.

Hard Power Down Mode

Hard Power Down Mode is entered by executing a STOP instruction. Disabling the oscillator driver cell stops the oscillator. When either RESET is driven active or a data byte is written to the DBBIN register by a master CPU, this mode will be exited

(as above). However, as the oscillator cell will require an initialization time, either RESET must be held active for sufficient time to allow the oscillator to stabilize. Program execution will resume as above.

INTERRUPTS

The FDC37B78x provides the two 8042 interrupts, the IBF and the Timer/Counter Overflow.

MEMORY CONFIGURATIONS

The FDC37B78x provides 2K of on-chip ROM and 256 bytes of on-chip RAM.

Register Definitions

Host I/F Data Register

The Input Data and Output Data registers are each 8 bits wide. A write to this 8 bit register will load the Keyboard Data Read Buffer, set the OBF flag and set the KIRQ output if enabled. A read of this register will read the data from the Keyboard Data or Command Write Buffer and clear the IBF flag. Refer to the KIRQ and Status register descriptions for more information.

Host I/F Status Register

The Status register is 8 bits wide. TABLE 59 shows the contents of the Status register.

TABLE 59 - STATUS REGISTER

D7	D6	D5	D4	D3	D2	D1	D0
UD	UD	UD	UD	C/D	UD	IBF	OBF

Status Register

This register is cleared on a reset. This register is read-only for the Host and read/write by the FDC37B78x CPU.

UDWritable by FDC37B78x CPU. These bits are user-definable.

C/D(Command Data)-This bit specifies whether the input data register contains data or a command (0 = data, 1 = command). During a host data/command write operation, this bit is set to "1" if SA2 = 1 or reset to "0" if SA2 = 0.

IBF(Input Buffer Full)- This flag is set to 1 whenever the host system writes data into the input data register. Setting this flag activates the FDC37B78x CPU's nIBF (MIRQ) interrupt if enabled. When the FDC37B78x CPU reads the input data register (DBB), this bit is automatically reset and the interrupt is cleared. There is no output pin associated with this internal signal.

OBF(Output Buffer Full) - This flag is set to whenever the FDC37B78x CPU write to the output data register (DBB). When the host system reads the output data register, this bit is automatically reset.

EXTERNAL CLOCK SIGNAL

The FDC37B78x Keyboard Controller clock source is a 12 MHz clock generated from a 14.318 MHz clock. The reset pulse must last for at least 24 16 MHz clock periods. The pulse-width requirement applies to both internally (Vcc POR) and externally generated reset signals. In powerdown mode, the external clock signal is not loaded by the chip.

DEFAULT RESET CONDITIONS

The FDC37B78x has one source of reset: an external reset via the RESET_DRV pin. Refer to TABLE 60 for the effect of each type of reset on the internal registers.

TABLE 60 - RESETS

DESCRIPTION	HARDWARE RESET (RESET)
KCLK	Input
KDAT	Input
MCLK	Input
MDAT	Input
Host I/F Data Reg	N/A
Host I/F Status Reg	00H

N/A: Not Applicable

GATEA20 AND KEYBOARD RESET

The FDC37B78x provides two options for GateA20 and Keyboard Reset: 8042 Software Generated GateA20 and KRESET and Port 92 Fast GateA20 and KRESET.

PORT 92 FAST GATEA20 AND KEYBOARD RESET

Port 92 Register

This port can only be read or written if Port 92 has been enabled via bit 2 of the KRST_GA20 Register (Logical Device 7, 0xF0) set to 1.

This register is used to support the alternate reset (nALT_RST) and alternate A20 (ALT_A20) functions.

Name	Port 92
Location	92h
Default Value	24h
Attribute	Read/Write
Size	8 bits

Port 92 Register	
Bit	Function
7:6	Reserved. Returns 00 when read
5	Reserved. Returns a 1 when read
4	Reserved. Returns a 0 when read
3	Reserved. Returns a 0 when read
2	Reserved. Returns a 1 when read
1	ALT_A20 Signal control. Writing a 0 to this bit causes the ALT_A20 signal to be driven low. Writing a 1 to this bit causes the ALT_A20 signal to be driven high.
0	Alternate System Reset. This read/write bit provides an alternate system reset function. This function provides an alternate means to reset the system CPU to effect a mode switch from Protected Virtual Address Mode to the Real Address Mode. This provides a faster means of reset than is provided by the Keyboard controller. This bit is set to a 0 by a system reset. Writing a 1 to this bit will cause the nALT_RST signal to pulse active (low) for a minimum of 1 μ s after a delay of 500 ns. Before another nALT_RST pulse can be generated, this bit must be written back to a 0.

nGATEA20		
8042 P21	ALT_A20	System nA20M
0	0	0
0	1	1
1	0	1
1	1	1

Bit 0 of Port 92, which generates the nALT_RST signal, is used to reset the CPU under program control. This signal is AND'ed together externally with the reset signal (nKBDRST) from the keyboard controller to provide a software means of resetting the CPU. This provides a faster means of reset than is provided by the keyboard controller. Writing a 1 to bit 0 in the Port 92 Register causes this signal to pulse low for a minimum of 6 μ s, after a delay of a minimum of 14 μ s.

Before another nALT_RST pulse can be generated, bit 0 must be set to 0 either by a system reset or a write to Port 92. Upon reset, this signal is driven inactive high (bit 0 in the Port 92 Register is set to 0).

If Port 92 is enabled, i.e., bit 2 of KRST_GA20 is set to 1, then a pulse is generated by writing a 1 to bit 0 of the Port 92 Register and this pulse is AND'ed with the pulse generated from the 8042. This pulse is output on pin KRESET and its polarity is controlled by the GPI/O polarity configuration.

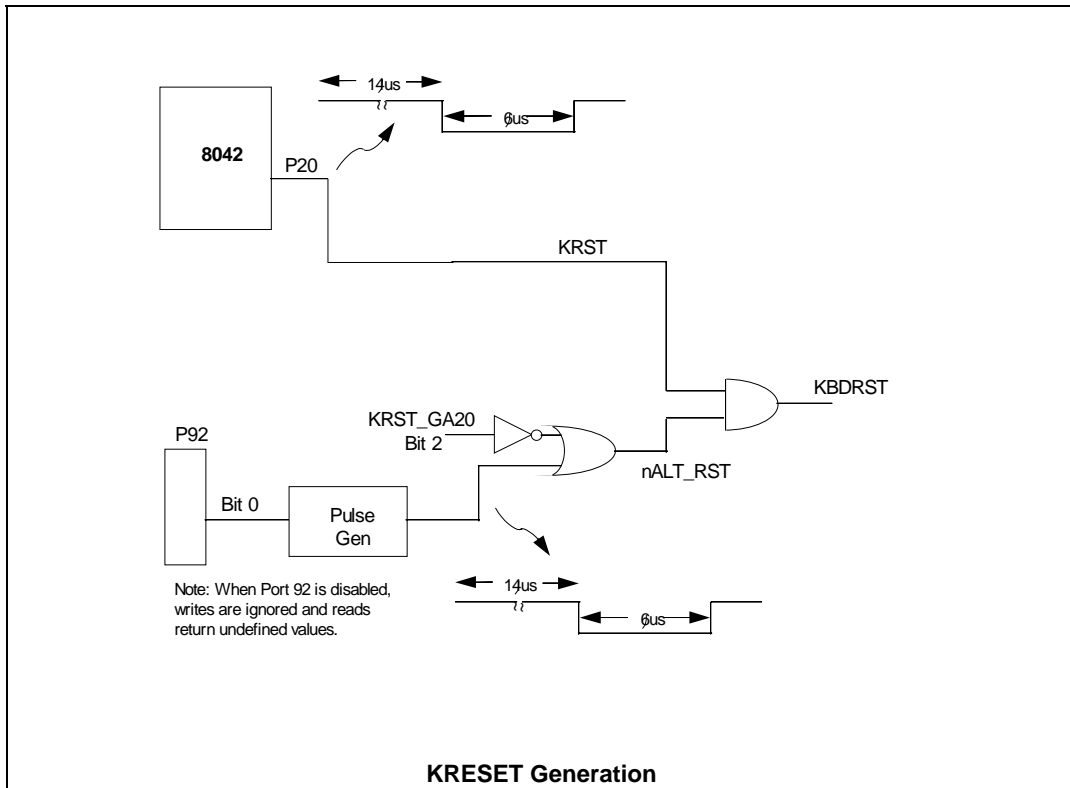

Bit 1 of Port 92, the ALT_A20 signal, is used to force nA20M to the CPU low for support of real mode compatible software. This signal is externally OR'ed with the A20GATE signal from the keyboard controller and CPURST to control the nA20M input of the CPU. Writing a 0 to bit 1 of the Port 92 Register forces ALT_A20 low. ALT_A20 low drives nA20M to the CPU low, if A20GATE from the keyboard controller is also low. Writing a 1 to bit 1 of the Port 92 Register forces ALT_A20 high. ALT_A20 high drives nA20M to the CPU high, regardless of the state of A20GATE from the keyboard controller. Upon reset, this signal is driven low.

8042 P17 Functions

8042 function P17 is implemented as in a true 8042 part. Reference the 8042 spec for all timing. A port signal of 0 drives the output to 0. A port signal of 1 causes the port enable signal to drive the output to 1 within 20-30nsec. After several (# TBD) clocks, the port enable goes away and the internal 90µA pull-up maintains the output signal as 1.

In 8042 mode, the pins can be programmed as open drain. When programmed in open drain mode, the port enables do not come into play. If the port signal is 0 the output will be 0. If the port signal is 1, the output tristates: an external pull-up can pull the pin high, and the pin can be shared i.e., P17 and nSMI can be externally tied together. In 8042 mode, the pins cannot be programmed as input nor inverted through the GP configuration registers.

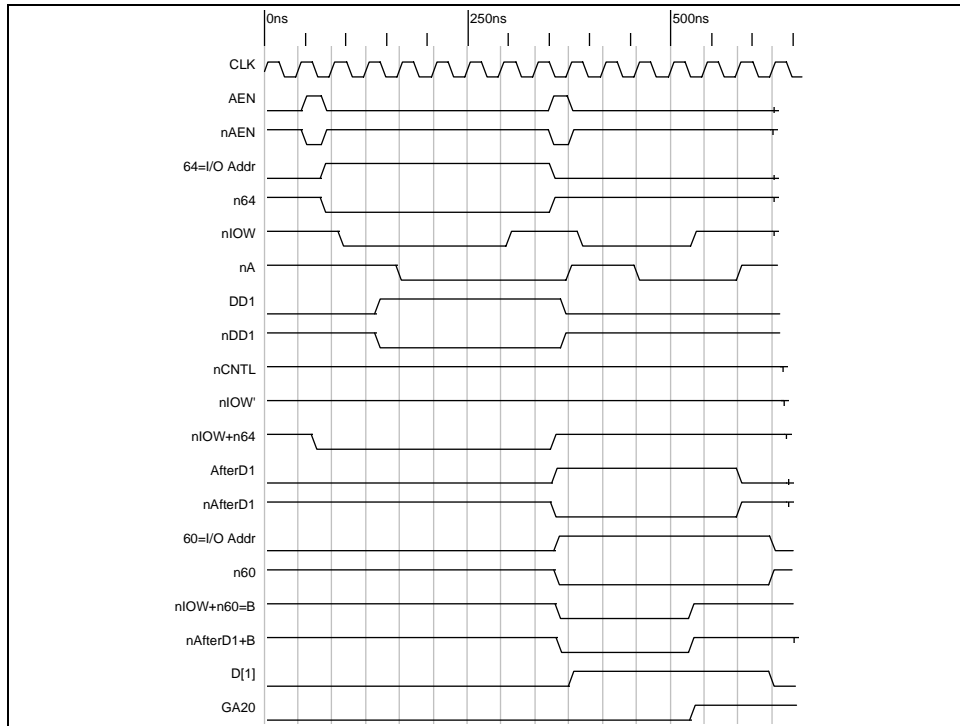

Gate A20 Turn-On Sequence Timing

When writing to the command and data port with hardware speedup, the IOW timing shown in the figure titled "IOW Timing for Port 92" in the Timing Diagrams Section is used. This setup

time is only required to be met when using hardware speedup; the data must be valid a minimum of 0 nsec from the leading edge of the write and held throughout the entire write cycle.

RTC INTERFACE

The ISA interface is functionally compatible with the 8042-style host interface. It consists of the D0-7 data bus, the nIOR, nIOW and the Status

register, Input Data register, and Output Data register. Table 61 shows how the interface decodes the control signals. In addition to the above signals, the host interface includes keyboard and mouse IRQs.

Table 61 - ISA I/O Address Map
Addresses 0x60, 0x64, 0x70 and 0x71 are qualified by AEN

ISA ADDRESS*	BLOCK	FUNCTION
0x70 (R/W)	RTC	Address Register
0x71 (R/W)	RTC	Data Register
Base*	RTC Bank 1	Address Register
Base* + 1	RTC Bank 1	Data Register

*Bank 0 is at 70h. Bank 1 is relocatable via the RTC Mode Register and the Secondary Base Address for RTC Bank 1 (CR62 and CR63). See Configuration section.

RTC Address Register

Writing to this register sets the CMOS address that will be read or written.

RTC Data Register

A read of this register will read the contents of the selected CMOS register. A write to this register will write to the selected CMOS register.

REAL TIME CLOCK

The Real Time Clock is a complete time of day clock with a day of month alarm, calendar (up to the year 9999), a programmable periodic interrupt, and a programmable square wave generator.

Features

Counts seconds, minutes, and hours of the day. Counts days of the week, date, month, year and century.

Day of Month Wake-Up Alarm

Binary or BCD representation of time, calendar and alarms.

Three interrupts - each is separately software maskable. (No daylight savings time)

256 Bytes of CMOS RAM.

Port Definition and Description

OSCILLATOR

Crystal Oscillator input. A 32.768 kHz crystal connected externally on the XTAL1 and XTAL2 pins generates the 32.768 kHz RTC input clock. Maximum clock frequency is 32.768 KHz.

RTC Reset

The clock, calendar, or RAM functions are not affected by the system reset (RESET_DRV active). When the RESET_DRV pin is active (i.e., system reset) and the battery voltage is above 1 volt nominal, the following occurs:

- 1) Periodic Interrupt Enable (PIE) is cleared to 0.
- 2) Alarm Interrupt Enable (AIE) bit is cleared to 0.
- 3) Update Ended Interrupt Enable (UIE) bit is cleared to 0.
- 4) Update Ended Interrupt Flag (UF) bit is cleared to 0.
- 5) Interrupt Request Status Flag (IRQF) bit is cleared to 0.
- 6) Periodic Interrupt Flag (PIF) is cleared to 0.
- 7) The RTC and CMOS registers are not accessible.
- 8) Alarm Interrupt Flag (AF) is cleared to 0.
- 9) nIRQ pin is in high impedance state.

When RESET_DRV is active and the battery voltage is below 1-volt nominal, the following occurs:

1. Registers 00-0D are initialized to 00h.
2. Access to all registers from the host are blocked.

RTC Interrupt

The interrupt generated by the RTC is an active high output. The RTC interrupt output remains high as long as the status bit causing the interrupt is present and the corresponding interrupt-enable bit is set. Activating RESET_DRV or reading register C clears the RTC interrupt.

The RTC Interrupt is brought out by programming the RTC Primary Interrupt Select to a non-zero value. If IRQ 8 is selected then the polarity of this IRQ 8 output is programmable through a bit in the OSC Global Configuration Register.

Internal Registers

Table 62 shows the address map for bank 0 of the RTC; time, calendar, alarm, control, status bytes and 114 bytes of "CMOS" registers.

Table 62 - Real Time Clock Address Map, Bank 0

ADDRESS	REGISTER TYPE	REGISTER FUNCTION
0	R/W	Register 0: Seconds
1	R/W	Register 1: Seconds Alarm
2	R/W	Register 2: Minutes
3	R/W	Register 3: Minutes Alarm
4	R/W	Register 4: Hours
5	R/W	Register 5: Hours Alarm
6	R/W	Register 6: Day of Week
7	R/W	Register 7: Date of Month
8	R/W	Register 8: Month
9	R/W	Register 9: Year
A	R/W	Register A:
B	R/W	Register B: (Bit 0 is Read Only)
C	R	Register C:
D	R/W	Register D:VRT and Day of Month Alarm
0E-7Ch	R/W	Register E-7C: General Purpose
7Dh	R/W	Register 7D: Century Byte
7Eh	R/W	Register 7E: Control Register 1
7Fh	R/W	Register 7F:General Purpose

All 14 bytes are directly writable and readable by the host with the following exceptions:

- a. Register C is read only
- b. Bit 7 of Register A and Bit 7 of Register D are read only
- c. Bit 0 of Register B is read only

Table 63 shows Bank 1, the second bank of CMOS registers which contains an additional 128 bytes of general purpose CMOS registers.

All 128 bytes are directly writeable and readable by the host.

Table 63 - Real Time Clock Address Map, Bank 1

ADDRESS	REGISTER TYPE	REGISTER FUNCTION
0-7F	R/W	Register 0-7F: General Purpose

Note: CMOS Bank 1 is relocatable via the RTC Mode Register and the Secondary Base Address (CR62 and CR63). See Configuration Section.

Time, Calendar and Alarm

The processor program obtains time and calendar information by reading the appropriate locations. The program may initialize the time, calendar and alarm by writing to these locations. The contents of the time, calendar, century and alarm bytes can be in binary or BCD as shown in Table 64.

Before initializing the internal registers, the SET bit in Register B should be set to a "1" to prevent time/calendar updates from occurring. The program initializes the ten locations in the binary or BCD format as defined by the DM bit in Register B. The SET bit may now be cleared to allow updates.

The 12/24 bit in Register B establishes whether the hour locations represent 1 to 12 or 0 to 23. The 12/24 bit cannot be changed without reinitializing the hour locations. When the 12 hour format is selected, the high order bit of the hours byte represents PM when it is a "1".

Once per second, the time, calendar and alarm bytes, as well as the century byte switched to the

update logic to be advanced by one second and to check for an alarm condition. If any of these bytes are read at this time, the data outputs are undefined. The update cycle time is shown in Table 65. The update logic contains circuitry for automatic end-of-month recognition as well as automatic leap year compensation.

An alarm can be generated for day of month, day, hour, minute, or seconds. The alarm may be used in two ways. First, when the program inserts an alarm time in the appropriate date, hours, minutes and seconds alarm locations, the alarm interrupt is initiated at the specified time each day if the alarm enable bit is high. The second usage is to insert a "don't care" state in one or more of three alarm bytes. The "don't care" code is any hexadecimal byte from C0 to FF inclusive. That is the two most significant bits of each byte, when set to "1", create a "don't care" situation. An alarm interrupt each hour is created with a "don't care" code in the hours and date alarm location. Similarly, an alarm is generated every minute with "don't care" codes in the hours, date and minutes alarm bytes. The "don't care" codes in all three alarm bytes create an interrupt every second.

Table 64 - Time, Calendar and Alarm Bytes

ADD	REGISTER FUNCTION	BCD RANGE	BINARY RANGE
0h	Register 0: Seconds	00-59	00-3B
1h	Register 1: Seconds Alarm	00-59	00-3B
2h	Register 2: Minutes	00-59	00-3B
3h	Register 3: Minutes Alarm	00-59	00-3B
4h	Register 4: Hours	01-12 am	01-0C
	(12 hour mode)	81-92 pm	81-8C
	(24 hour mode)	00-23	00-17
5h	Register 5: Hours Alarm	01-12 am	01-0C
	(12 hour mode)	81-92 pm	81-8C
	(24 hour mode)	00-23	00-17
6h	Register 6: Day of Week	01-07	01-07
7h	Register 7: Day of Month	01-31	01-1F
8h	Register 8: Month	01-12	01-0C
9h	Register 9: Year	00-99	00-63
Dh	Date of Month Alarm	1-31	01-1F
7Dh	Century Byte	00-99	00-63
7Eh	Control Register 1		

Wake-up Alarm Function

The Alarm can be used as a wake-up alarm to turn on power to the system when the system is powered off. There are two bits used to control alarm. The Alarm wake-up function is enabled via the Alarm Enable bit, AIE. The Alarm Remember Enable bit, AL_REM_EN, in the RTC Control Register 1, is used to power-up the system upon return of power if the Alarm time has passed during loss of power. These bits function as follows:

If VTR is present: AIE controls whether or not the alarm is enabled as a wake-up function. If AIE is set and VTR=5V, the nPowerOn pin will go active (low) when the date/time is equal to the alarm date/time and the power supply will turn on the machine.

If VTR is not present: AL_REM_EN controls whether or not the alarm will power-up the system upon the return of VTR, regardless of the value of AIE. If AL_REM_EN is set and VTR=0 at the date/time that alarm 2 is set for, the nPowerOn pin will go active (low) as soon as VTR comes back and the machine will power-up.

Update Cycle

An update cycle is executed once per second if the SET bit in Register B is clear and the DV0-DV2 divider is not clear. The SET bit in the "1" state permits the program to initialize the time and calendar bytes by stopping an existing update and preventing a new one from occurring.

The primary function of the update cycle is to increment the seconds' byte, check for overflow, and increment the minute's byte when appropriate and so forth through to the year of the century byte. The update cycle also compares each alarm byte with the corresponding time byte and issues an alarm if a match or if a "don't care" code is present.

The length of an update cycle is shown in Table 65. During the update cycle, the time, calendar and alarm bytes are not accessible by the processor program. If the processor reads these locations before the update cycle is complete, the output will be undefined. The UIP (update in progress) status bit is set during the interval. When the UIP bit goes high, the update cycle will begin 244 μ s later. Therefore, if a low is read on the UIP bit, the user has at least 244 μ s before time/calendar data will be changed.

Table 65 - Update Cycle Time

INPUT CLOCK FREQUENCY	UIP BIT	UPDATE CYCLE TIME	MINIMUM TIME UPDATE CYCLE
32.768 kHz	1	1948 μ s	-
32.768 kHz	0	-	244 μ s

CONTROL AND STATUS REGISTERS, BANK 0

Bank 0 of the RTC has five registers that are accessible to the processor program at all times

when Bank 0 is enabled, even during the update cycle. Note Register D, Bits[6:0] are not accessible during an update cycle.

REGISTER A (AH)

MSB				LSB			
b7	b6	b5	b4	b3	b2	b1	b0
UIP	DV2	DV1	DV0	RS3	RS2	RS1	RS0

UIP

The update in progress bit is a status flag that may be monitored by the program. When UIP is a "1" the update cycle is in progress or will soon begin. When UIP is a "0" the update cycle is not in progress and will not be for at least 244 μ s. The time, calendar, and alarm information is fully available to the program when the UIP bit is zero. The UIP bit is a read- only bit and is not affected by RESET_DRV. Writing the SET bit in Register B to a "1" inhibits any update cycle and then clears the UIP status bit. The UIP bit is only valid when the RTC is enabled. Refer to Table 66.

divider chain. When the time/calendar is first initialized, the program may start the divider chain at the precise time stored in the registers. When the divider reset is removed the first update begins one-half second later. These three read/write bits are not affected by RESET_DRV.

DV2-0

Three bits are used to permit the program to select various conditions of the 22-stage divider chain. Table 66 shows the allowable combinations. The divider selection bits are also used to reset the

RS3-0

The four rate selection bits select one of 15 taps on the divider chain or disable the divider output. The selected tap determines rate or frequency of the periodic interrupt. The program may enable or disable the interrupt with the PIE bit in Register B. Table 67 lists the periodic interrupt rates and equivalent output frequencies that may be chosen with the RS0-RS3 bits. These four bits are read/write bits, which are not affected by RESET_DRV.

Table 66 - Divider Selection Bits

OSCILLATOR FREQUENCY	REGISTER A BITS			MODE
	DV2	DV1	DV0	
32.768 KHz	0	0	0	Reset Divider
32.768 KHz	0	0	1	Reset Divider
32.768 KHz	0	1	0	Normal Operate
32.768 KHz	0	1	1	Test
32.768 KHz	1	0	X	Test
	1	1	X	Reset Divider

Table 67 - Periodic Interrupt Rates

RATE SELECT				32.768 KHz TIME BASE	
RS3	RS2	RS1	RS0	PERIOD RATE OF INTERRUPT	FREQUENCY OF INTERRUPT
0	0	0	0	0.0	
0	0	0	1	3.90625 ms	256 Hz
0	0	1	0	7.8125 ms	128 Hz
0	0	1	1	122.070 μ s	8.192 KHz
0	1	0	0	244.141 μ s	4.096 KHz
0	1	0	1	488.281 μ s	2.048 KHz
0	1	1	0	976.562 μ s	1.024 KHz
0	1	1	1	1.953125 ms	512 Hz
1	0	0	0	3.90625 ms	256 Hz
1	0	0	1	7.8125 ms	128 Hz
1	0	1	0	15.625 ms	64 Hz
1	0	1	1	31.25 ms	32 Hz
1	1	0	0	62.5 ms	16 Hz
1	1	0	1	125 ms	8 Hz
1	1	1	0	250 ms	4 Hz
1	1	1	1	500 ms	2 Hz

REGISTER B (BH)

MSB				LSB			
b7	b6	b5	b4	b3	b2	b1	b0
SET	PIE	AIE	UIE	RES	DM2	24/12	DSE

SET

When the SET bit is a "0", the update functions normally by advancing the counts once per second. When the SET bit is a "1", an update

cycle in progress is aborted and the program may initialize the time and calendar bytes without an update occurring in the middle of initialization. SET is a read/write bit which is not modified by RESET_DRV or any internal functions.

PIE

The periodic interrupt enable bit is a read/write bit which allows the periodic-interrupt flag (PF) bit in Register C to cause the IRQB port to be driven

low. The program writes a "1" to the PIE bit in order to receive periodic interrupts at the rate specified by the RS3-RS0 bits in Register A. A zero in PIE blocks IRQB from being initiated by a

periodic interrupt, but the periodic flag (PF) is still set at the periodic rate. PIE is not modified by any internal function, but is cleared to "0" by a RESET_DRV.

AIE

The alarm interrupt enable bit is a read/write bit, which when set to a "1" permits the alarm flag (AF) bit in Register C to assert IRQB. An alarm interrupt occurs for each second that the three time Bytes equal the three alarm bytes (including a "don't care" alarm code of binary 11XXXXXX). When the AIE bit is a "0", the AF bit does not initiate an IRQB signal. The RESET_DRV port clears AIE to "0". The AIE bit is not affected by any internal functions.

UIE

The update-ended interrupt enable bit is a read/write bit which enables the update-end flag (UF) bit in Register C to assert IRQB. The RESET_DRV port or the SET bit going high clears the UIE bit.

RES

Reserved - read as "0".

DM

The data mode bit indicates whether time and calendar updates are to use binary or BCD formats. The DM bit is written by the processor program and may be read by the program, but is not modified by any internal functions or by RESET_DRV. A "1" in DM signifies binary data, while a "0" in DM specifies BCD data.

24/12

The 24/12 control bit establishes the format of the hours byte as either the 24 hour mode if set to a "1", or the 12 hour mode if cleared to a "0". This is a read/write bit which is not affected by RESET_DRV or any internal function.

DSE

The daylight savings enable bit is read only and is always set to a "0" to indicate that the daylight savings time option is not available.

REGISTER C (CH) - READ ONLY REGISTER

MSB				LSB			
b7	b6	b5	b4	b3	b2	b1	b0
IRQF	PF	AF	UF	0	0	0	0

IRQF

The interrupt request flag is set to a "1" when one or more of the following are true:

- PF = PIE = 1
- AF = AIE = 1
- UF = UIE = 1

Any time the IRQF bit is a "1", the IRQB signal is driven low. All flag bits are cleared after Register C is read or by the RESET_DRV port.

PF

The periodic interrupt flag is a read-only bit which is set to a "1" when a particular edge is detected

on the selected tap of the divider chain. The RS3-RS0 bits establish the periodic rate. PF is set to a "1" independent of the state of the PIE bit. PF being a "1" sets the IRQF bit and initiates an IRQB signal when PIE is also a "1". The PF bit is cleared by RESET_DRV or by a read of Register C.

AF

The alarm interrupt flag when set to a "1" indicates that the current time has matched the alarm time. A "1" in AF causes a "1" to appear in IRQF and the IRQB port to go low when the AIE bit is also a "1". A RESET_DRV or a read of Register C clears the AF bit.

UF

The update-ended interrupt flag bit is set after each update cycle. When the UIE bit is also a "1", the "1" in UF causes the IRQF bit to be set and asserts IRQB. A RESET_DRV or a read of Register C causes UF to be cleared.

b3-0

The unused bits of Register C are read as zeros and cannot be written.

REGISTER D (DH) - BITS[7,6] ARE READ-ONLY, BITS[5:0] ARE READ/WRITE

MSB				LSB			
b7	b6	b5	b4	b3	b2	b1	b0
VRT	0	Date Alarm					

VRT

When a "1", this bit indicates that the contents of the RTC are valid. A "0" appears in the VRT bit when the battery voltage is low. The VRT bit is a read-only bit, which can only be set by a read of Register D. Refer to Power Management for the conditions when this bit is reset. The processor program can set the VRT bit when the time and calendar are initialized to indicate that the time is valid.

b6

Read as zero and cannot be written.

b5:b0

Date Alarm; These bits store the date of month alarm value. If set to 000000b, then a don't care state is assumed. The host must configure the date alarm for these bits to do anything, yet they can be written at any time. If the date alarm is not enabled, these bits will return zeros. These bits are not affected by RESET_DRV.

Note: Bits[6:0] are not accessible during an update cycle.

REGISTER 7E (7Eh) CONTROL REGISTER 1

Default is 0; cleared upon Vbat POR. This register is battery backed-up.

D7	D6	D5	D4	D3	D2	D1	D0
XTAL_CAP	0	0	0	0	VTR_POR_EN	VTR_POR_OFF	AL_REM_EN

BIT 0 - AL_REM_EN

One of the two control bits for the alarm wakeup function; it is the “remember” enable bit for the second alarm. This bit, if set to 1, will cause the system to power-up upon return of power if the alarm 2 time has passed during loss of power. It is only applicable when VTR=0. This bit is independent of the other control bit for the alarm wakeup function, AIE.

If AL_REM_EN is set and VTR=0 at the date/time that the alarm is set for, the nPowerOn pin will go active (low) and the machine will power-up as soon as VTR comes back.

Bit 1 – VTR_POR_OFF

If VTR_POR_OFF is set, the nPowerOn pin will go inactive (float) and the main power (Vcc) will remain off when the VTR POR occurs. The software must not set VTR_POR_OFF and VTR_POR_EN at the same time.

BIT 2 - VTR_POR_EN

The enable bit for VTR POR. If VTR_POR_EN is set, the nPowerOn pin will go active (low) and the machine will power-up as soon as a VTR POR occurs. The software must not set VTR_POR_OFF and VTR_POR_EN at the same time.

Bits 3:6 - Reserved

Read as zero, ignore writes

Bit 7 - XTAL_CAP

This bit is used to specify the 32Khz XTAL load capacitance (12pF vs. 6pF):
0=12pF, 1=6pF.

Registers 0Eh-7Ch, 7Fh in Bank 0 and 00h-7Fh in Bank 1: General Purpose

Registers 0Eh-7Ch, 7Fh in Bank 0 and 00h-7Fh in Bank 1 are general purpose CMOS registers. These registers can be used by the host and are fully available during the time update cycle. The contents of these registers are preserved by the battery power.

Interrupts

The RTC includes three separate fully-automatic sources of interrupts to the processor. The alarm interrupt may be programmed to occur at rates from one-per-second to one-a-day. The periodic interrupt may be selected for rates from half-a-second to 122.070 μ s. The update ended interrupt may be used to indicate to the program that an update cycle is completed. Each of these independent interrupts are described in greater detail in other sections.

The processor program selects which interrupts, if any, it wishes to receive by writing a "1" to the appropriate enable bits in Register B. A "0" in an enable bit prohibits the IRQB port from being asserted due to that interrupt cause. When an interrupt event occurs a flag bit is set to a "1" in Register C. Each of the three interrupt sources have separate flag bits in Register C, which are set independent of the state of the corresponding enable bits in Register B. The flag bits may be used with or without enabling the corresponding enable bits. The flag bits in Register C are cleared (record of the interrupt event is erased) when Register C is read. Double latching is included in Register C to ensure the bits that are set are stable throughout the read cycle. All bits which are high when read by the program are cleared, and new interrupts are held until after the read cycle. If an interrupt flag is already set when the interrupt becomes enabled, the IRQB port is immediately activated, though the interrupt initiating the event may have occurred much earlier.

When an interrupt flag bit is set and the corresponding interrupt-enable bit is also set, the IRQB port is driven low. IRQB is asserted as long as at least one of the three interrupt sources has its flag and enable bits both set. The IRQF bit in Register C is a "1" whenever the IRQB port is being driven low.

Frequency Divider

The RTC has 22 binary divider stages following the clock input. The output of the divider is a 1 Hz signal to the update-cycle logic. The divider is controlled by the three divider bits (DV3-DV0) in Register A. As shown in Table

66 the divider control bits can select the operating mode, or be used to hold the divider chain reset which allows precision setting of the time. When the divider chain is changed from reset to the operating mode, the first update cycle is one-half second later. The divider control bits are also used to facilitate testing of the RTC.

Periodic Interrupt Selection

The periodic interrupt allows the IRQB port to be triggered from once every 500 ms to once every 122.07 μ s. As Table 67 shows, the periodic interrupt is selected with the RS0-RS3 bits in Register A. The periodic interrupt is enabled with the PIE bit in Register B.

SOFT POWER MANAGEMENT

This chip employs soft power management to allow the chip to enter low power mode and to provide a variety of wakeup events to power up the chip. This technique allows for software control over powerdown and wakeup events. In low power mode, the chip runs off of the trickle voltage, VTR. In this mode, the chip is ready to power up from either the power button or from one of a number of wakeup events including pressing a key, touching the mouse or receiving data from one of the UARTs. The alarm can also be set to power up the system at a predetermined time to perform one or more tasks.

The implementation of Soft Power Management is illustrated in Figure 11. A high to low transition on the Button input or on any of the enabled wakeup events (SPx) causes the nPowerOn output to go active low which turns on the main power supply. Even if the power supply is completely lost (i.e., VTR is not present) the power supply can still be turned on upon the return of VTR. This is accomplished by an alarm event that has already passed (if the alarm remember bit is enabled) or by a VTR power on reset (if the VTR POR bit is enabled). These bits are described in the RTC

section. The chip can also be programmed to always stay off when the AC power returns. (See VTR_POR_OFF in the RTC section.)

The Button input can be used to turn off the power supply after a debounce delay. The power supply can also be turned off under software control (via a write to register WDT_CTRL with bit 7 set).

Configuration registers L8-CR_B0 and L8-CR_B1 select the wakes-up events (SPx). The Configuration registers L8-CR_B2 and L8-CR_B3 indicate the wake-up event status. The possible wake-events are:

- UART1 and UART 2 Ring Indicator Pin
- Keyboard and Mouse clock Pin
- Group Interrupt 1, Group Interrupt 2
- IRRX2 input pin
- RTC Alarm
- UART 1 and UART 2 Receive Data Pin
- nRING pin
- Consumer IR (CIR)
- Power Button input pin
- VTR_POR

FIGURE 3 - SOFT POWER MANAGEMENT FUNCTIONAL DIAGRAM

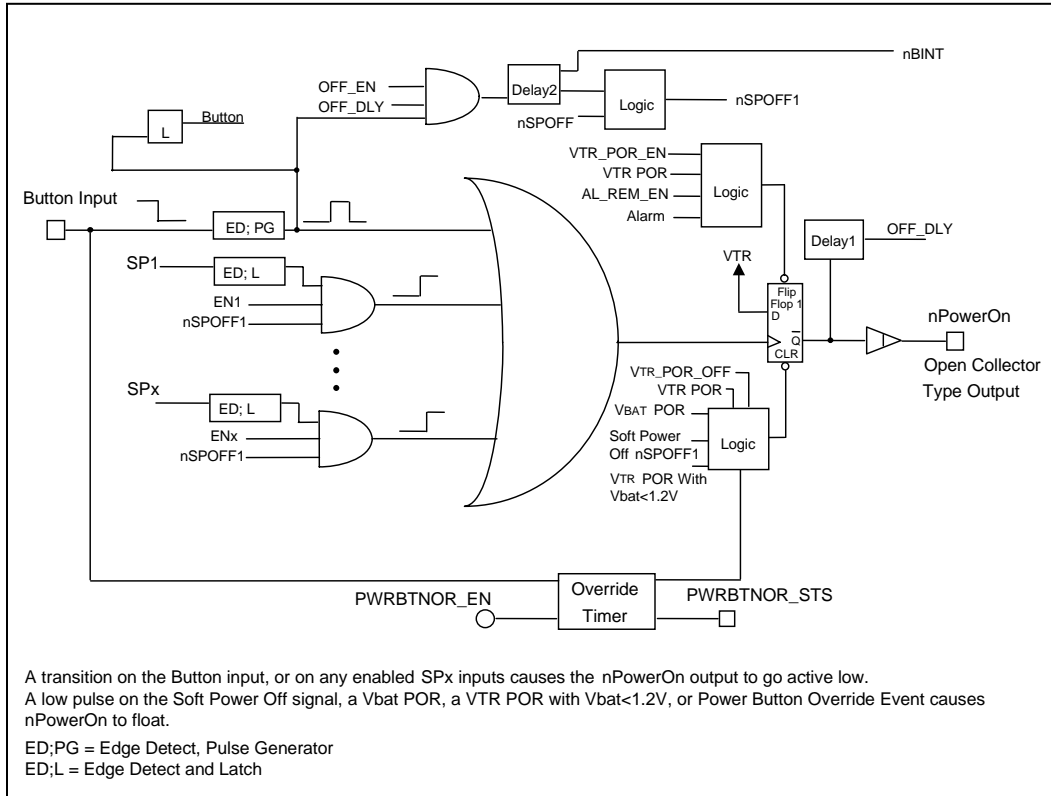

Note 1: All soft power management functions run off of VTR. When VTR is present, it supplies power to the RTC. When VTR is not present, Vbat supplies power to the RTC and Flip Flop 1.

Note 2: Flip Flop 1 is battery backed-up so that it returns the last valid state of the machine.

Note 3: A battery backed-up enable bit in the alarm control register can be set to force Flip Flop 1 in the soft power management circuit to come up 'on' if an alarm occurred when VTR was not present. This is gated into wakeup circuitry. Refer to the AL_REM_EN Bit description in the RTC Control Register section for more information.

Note 4: A battery backed-up enable bit in the alarm control register can be set to force Flip Flop 1 to come up 'off' after a VTR POR, see VTR_POR_OFF.

REGISTERS

The following registers can be accessed when in configuration mode at Logical Device 8, Registers B0-B3, B8 and F4, and when not in configuration they can be accessed through the Index and Data Register. All soft power management configuration registers are battery backed up and are reset on Vbat POR.

Soft Power Enable Registers

SOFT POWER ENABLE REGISTER 1
(Configuration Register B0, Logical Device 8)

This register contains the enable bits for the wake-up function of the nPowerOn bit. When enabled, these bits allow their corresponding function to turn on power to the system.

SOFT POWER ENABLE REGISTER 2
(Configuration Register B1, Logical Device 8)

This register contains additional enable bits for the wake-up function of the nPowerOn bit. When enabled, these bits allow their corresponding function to turn on power to the system. It also contains OFF_EN: After power up, this bit defaults to 1, i.e., enabled. This bit allows the software to enable or disable the button control of power off.

Soft Power Status Registers

Soft Power Status Register 1
(Configuration Register B2, Logical Device 8)

This register contains the status for the wake-up events. Note: The status bit gets set if the wakeup event occurs, whether or not it is enabled as a wakeup function by setting the corresponding bit in Soft Power Enable Register 1. However, only the enabled wakeup functions will turn on power to the system.

Soft Power Status Register 2
(Configuration Register B3, Logical Device 8)

This register contains additional status for the wake-up events. Note: The status bit gets set if the wakeup event occurs, whether or not it is enabled as a wakeup function by setting the corresponding bit in Soft Power Enable Register

2. However, only the enabled wakeup functions will turn on power to the system.

Soft Power Control Registers

WDT_CTRL
(Configuration Register F4, Logical Device 8)
This register is used for soft power management and watchdog timer control. Bits [7:5] are for soft power management: SPOFF, Restart_Cnt, Stop_Cnt.

Delay 2 Time Set Register
(Configuration Register B8, Logical Device 8)
This register is used to set Delay 2 to value from 500msec to 32sec. The default value is 500msec.

The power button has an override event as required by the ACPI specification. If the user presses the power button for more than four seconds while the system is in the working state, a hardware event is generated and the system will transition to the off state. There are status bits and enable bits associated with this feature in the PM1_BLK registers. See the ACPI section.

This override event utilizes power button logic to determine that the power button (Button_In) has been pressed for more than four seconds. The override enable/disable bit, PWRBTNOR_EN, allows this override function to be turned on/off. If enabled, this override event will result in setting the override status bit, PWRBTNOR_STS (to be cleared by writing a 1 to its bit position - writing a 0 has no effect), clearing the regular button status bit, PWRBTN_STS, and generating an event to be routed into the soft power management logic to turn off the system. The override status bit alerts the system upon power-up that an override event was used to power down the system, and will be used to properly power-up the system.

Figure 11 shows the soft power management logic with the override timer path from the button input. The override timer counts while the button is held (in the present implementation this would be when the button input is high) and is cleared

upon release of the button. It has a 0.5 second or faster resolution (run off of the 32kHz clock divided down) and the minimum time for triggering the override power down is four seconds, with a maximum of 4.5 seconds. The

timer output will pulse the clear on the Flip Flop 1.

Figure 12 illustrates the timing of the blanking period relative to Button_In and nPowerOn for the override event.

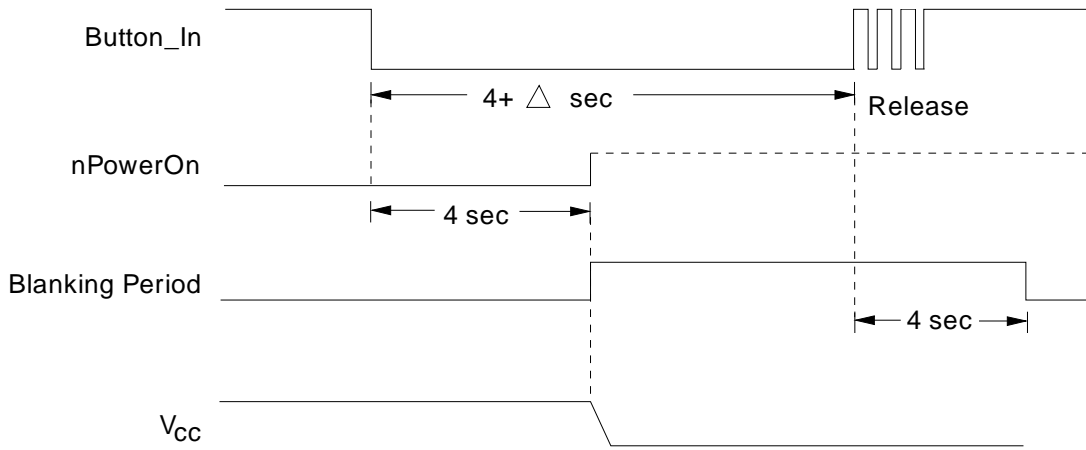

FIGURE 4 - BLANKING PERIOD

ACPI/PME/SMI FEATURES

ACPI Features

The FDC37B78x supports ACPI as described in this section. These features comply with the ACPI Specification, Revision 1.0.

Legacy/ACPI Select Capability

This capability consists of an SMI/SCI switch which is required in a system that supports both legacy and ACPI power management models. This is due to the fact that the system software for legacy power management consists of the SMI interrupt handler while for ACPI it consists of the ACPI driver (SCI interrupt handler). This support uses Logical Device A at 0x0A to hold the address pointers to the ACPI power management register block, PM1_BLK, which consists of run-time registers. Included in the PM1_BLK is an enable bit, SCI_EN, to allow the SCI interrupt to be generated upon an enabled SCI event. This SCI interrupt can be switched out to the nPME/SCI pin or routed to one of the parallel interrupts, IRQ11, or any Serial IRQ frame. Note that the Serial IRQ is not available under V_{TR} power. The polarity and output type (open collector or push-pull) of the SCI is selected through the IRQ MUX Register.

The software power management events (those that generate an SMI in legacy mode and an SCI in ACPI mode) are controlled by the EN_SMI and SCI_EN bits. The SCI enable bit, SCI_EN, is located in the PM1_CNTRL register, bit 0. This bit is used in conjunction with EN_SMI, bit 7 of the SMI enable register 2, to enable either SCI or SMI (or both). For legacy power management, the EN_SMI bit is used; if set, it routes the power management events to the SMI interrupt logic. For ACPI power management, the SCI_EN bit is used; if set, it routes the power management events to the SCI interrupt logic.

Power Button With Override

The power button has a status and an enable bit in the PM1_BLK of registers to provide an SCI upon the button press. The power button can also turn the system on and off through the soft power management logic. The power button also has an override event as required by the ACPI specification. See The Soft Power Management Section. This override event is described as follows: If the user presses the power button for more than 4 seconds while the system is in the working state, a hardware event is generated and the system will transition to the off state. There are status and enable bits associated with this feature in the PM1_BLK registers.

RTC Alarm

The ACPI specification requires that the RTC alarm generate a hardware wake-up event from the sleeping state. The RTC alarm event can be enabled as both a PME and an SCI event through bits in the PM1_BLK of registers. In addition, the can also turn the system on due to the RTC alarm through the soft power management logic.

There is a bit in the PME Enable Register and the PME Status Register 1 to enable the RTC alarm event as a nPME event and to read its status. The status bit is set when the RTC generates an alarm event and is cleared by writing a 1 to this bit (writing a 0 has no effect). When the RTC generates an alarm event, the RTC_PME_STS bit will be set. If the RTC_PME_EN bit is set, an RTC PME power management event will be generated.

For SCI, the RTC_STS and RTC_EN bits are in the PM1_STS and PM1_EN registers.

General Purpose ACPI Events

The General Purpose ACPI events are enabled through the SCI_EN1 bit in the GPE_EN register. This bit, if set, allows any of the enabled PME events to generate an SCI. In addition, if the DEVINT_EN bit in the PME_EN 1 Register is set, and if the EN_SMI_PME bit in the SMI_EN 2 register is set, then any of the SMI Events can also generate an SCI. See the SCI/PME and SMI/PME logic diagrams below.

Device Sleep States

Each device in the FDC37B78x supports two device sleep states, D0 (on) and D3 (off). The D3 state corresponds to the PCI defined D3cold state. With all devices off, the part is powered

either by main power (Vcc) or standby power (Vtr), depending on the system sleep state. In both cases, the part can provide wakeup capability through the soft power management logic and generate a nPME or nSCI. In an ACPI system, the devices are powered on and off through control methods.

Wake Events

Wake events are events that turn power on (activate nPowerOn output) if enabled. These events can also be enabled as SMI, SCI and nPME events as shown in the following table. In addition, these wake events set the WAK_STS bit if enabled (see ACPI PM1_STS2 Register description).

	WAKE EVENTS	INPUT TO SOFT POWER MANAGEMENT	SMI/SCI/PME GENERATION
Pins	KCLK	KCLK	SMI/SCI/PME
	MCLK	MCLK	SMI/SCI/PME
	IRRX2 (Includes CIR)	IRRX2	SMI/SCI/PME
	RXD2/IRRX (Includes CIR)	RXD2/IRRX	SMI/SCI/PME
	(CIR)	CIR	SMI/SCI/PME
	RXD1	RXD1	SMI/SCI ¹ /PME ¹
	nRI1	nRI1	SMI/SCI/PME
	nRI2	nRI2	SMI/SCI/PME
	nRING	nRING	SMI/SCI/PME
	Button	Button	SMI/SCI ² /PME ¹
	GP10-17	GPINT1	SMI/SCI ¹ /PME
GP50-54, GP60-67	GPINT2	SMI/SCI ¹ /PME ¹	
Internal	RTC Alarm (includes AL_REM)	RTC Alarm + AL_REM	SCI ²
Signals	VTR POR	VTR POR	SCI

Note 1: These SCI/PME events are SMI events that are enabled through DEVINT_EN

Note 2: These SCI events have Status and Enable bits in the PM1 registers

The following are SMI events that are not wake events:

- Floppy Interrupt
- Parallel Port Interrupt
- WDT
- P12
- UART1 and UART2 interrupts
- Mouse and keyboard interrupts
- SLP_EN

Any wakeup logic that affects the configuration of the wakeup events is implemented so that the configuration of the wakeup events is retained (in the event of total power loss) upon Vtr POR.

PME SUPPORT

The FDC37B78x offers support for PCI power management events (PMEs). A power management event is requested by a PCI function via the assertion of the nPME signal. The assertion and deassertion of nPME is asynchronous to the PCI clock. In the FDC37B78x, active transitions on the ring indicator inputs nRI1 and nRI2 or the nRING pin, valid NEC infrared remote control frames, active keyboard-clock edges, active mouse-clock edges, RTC alarm, and GPIOs GP10-GP17 can directly assert the nPME signal. In addition, if the DEVINT_EN bit in the PME_EN 1 Register is set, and if the EN_SMI_PME bit in the SMI_EN 2 register is set, then any of the SMI Events can also generate a nPME. See the SCI/PME and SMI/PME logic diagrams in FIGURE 5 and FIGURE 6.

nPME functionality is controlled by the runtime registers at <PM1_BLK>+Ch through <PM1_BLK>+11h. The PME Enable bit, PME_EN, globally controls PME Wake-up events.

ACPI/PME/SMI REGISTERS

Logical Device A in the configuration section contains the address pointer to the ACPI power management register block, and PM1_BLK. These are run-time registers; Included in the PM1_BLK is an enable bit to allow the SCI group interrupt to be routed to any serial interrupt or the IRQ11 pin, or onto the nPME/SCI pin. Note: See IRQ mux control register for SCI/PME/SMI selection function and pin configuration bits.

Register Description

The ACPI register model consists of a number of fixed register blocks that perform designated functions. A register block consists of a number of registers that perform Status, Enable and Control functions. The ACPI specification deals with events (which have an associated interrupt status and enable bits, and sometimes an associated control function) and control features. The status registers illustrate what defined function is requesting ACPI interrupt services

When PME_EN is inactive, the nPME signal can not be asserted. When PME_EN is asserted, any wake source whose individual PME Wake Enable register bit is asserted can cause nPME to become asserted. The PME Wake Status register indicates which wake source has asserted the nPME signal. The PME Status bit, PME_STS, is asserted by active transitions of PME Wake sources. PME_STS will become asserted independent of the state of the global PME enable, PME_EN.

In the FDC37B78x the nPME pin is an open drain, active low, driver. The FDC37B78x nPME pin is fully isolated from other external devices that might pull the PCI nPME signal low; i.e., the PCI nPME signal is capable of being driven high externally by another active device or pullup even when the the FDC37B78x VDD is grounded, providing VTR power is active. The FDC37B78x nPME driver sinks 6mA at .55V max (see section 4.2.1.1 DC Specifications, page 122, in the PCI Local Bus Specification, Revision 2.1).

(SCI). Any status bit in the ACPI specification has the following attributes:

- A. Status bits are only set through some defined "hardware event."
- B. Unless otherwise noted, Status bits are cleared by writing a "HIGH" to that bit position, and upon VTR POR. Writing a 0 has no effect.
- C. Status bits only generate interrupts while their associated bit in the enable register is set.
- D. Function bit positions in the status register have the same bit position in the enable register (there are exceptions to this rule, special status bits have no enables).

Note that this implies that if the respective enable bit is reset and the hardware event occurs, the respective status bit is set, however no interrupt is generated until the enable bit is set. This allows software to test the state of the event (by examining the status bit) without necessarily generating an interrupt. There are a special class of status bits that have no respective enable bit,

these are called out specifically, and the respective enable bit in the enable register is marked as reserved for these special cases.

The enable registers allow the setting of the status bit to generate an interrupt. As a general rule there is an enable bit in the enable register for every status bit in the status register. The control register provides special controls for the associated event, or special control features that are not associated with an interrupt event. The ordering of a register block is the status registers, followed by enable registers, followed by control registers.

TABLE 68 and TABLE 69 list the PM1/GPE and PME/SMI/MSM register blocks and the locations

of the registers contained in these blocks. All of these registers are powered by VTR and battery backed-up and are reset on Vbat POR.

Wakeup Event Configuration is Retained by Battery Power

To preserve the configuration of the wakeup functions that were programmed prior to the loss of Vtr upon its return, the soft power management registers, PME, SCI, SMI registers and GPIO registers are all powered by the battery. These registers are reset to their default values only on Vbat POR. These registers are described in the sections below.

Register Block

The registers in this block are powered by VTR and battery backed up.

TABLE 68 - PM1/GPE REGISTER BLOCK

Register	Size	Address
PM1_STS 1	8	<PM1_BLK>
PM1_STS 2	8	<PM1_BLK>+1h
PM1_EN 1	8	<PM1_BLK>+2h
PM1_EN 2	8	<PM1_BLK>+3h
PM1_CNTRL 1	8	<PM1_BLK>+4h
PM1_CNTRL 2	8	<PM1_BLK>+5h
Reserved	8	<PM1_BLK>+6h
Reserved	8	<PM1_BLK>+7h
GPE_STS 1	8	<PM1_BLK>+8h
GPE_EN 1	8	<PM1_BLK>+9h
Reserved	8	<PM1_BLK>+Ah
Reserved	8	<PM1_BLK>+Bh

TABLE 69 - PME/SMI/MSC REGISTER BLOCK

Register	Size	Address
PME_STS 1	8	< PM1_BLK>+Ch
PME_STS 2	8	< PM1_BLK>+Dh
PME_EN 1	8	< PM1_BLK>+Eh
PME_EN 2	8	< PM1_BLK>+Fh
PME_STS	8	< PM1_BLK>+10h
PME_EN	8	< PM1_BLK>+11h
SMI_STS 1	8	< PM1_BLK>+12h
SMI_STS 2	8	< PM1_BLK>+13h
SMI_EN 1	8	< PM1_BLK>+14h
SMI_EN 2	8	< PM1_BLK>+15h
MSC_STS	8	< PM1_BLK>+16h
Reserved	8	< PM1_BLK>+17h

TABLE 70 shows the block size and range of base addresses for each block.

TABLE 70 - REGISTER BLOCK ATTRIBUTES

Block Name	Block Size	Base Address Range
PM1_BLK	24-bytes	0-FFF

ACPI REGISTERS

In the FDC37B78x, the PME wakeup events can be enabled as SCI events through the SCI_STS1 and SCI_EN1 bits in the GPE status and enable registers. See PME Interface and SMI/PME/SCI logic sections.

Power Management 1 Status Register 1 (PM1_STS 1)

Register Location: <PM1_BLK> System I/O Space

Default Value: 00h on Vbat POR

Attribute: Read/Write (Note 0)

Size: 8-bits

BIT	NAME	DESCRIPTION
0-7	Reserved	Reserved. These bits always return a value of zero.

Note 0: All bits described as "reserved" in writeable registers must be written with the value 0 when the register is written.

Note 1: This bit is set by hardware and can only be cleared by software writing a one to this bit position and by Vbat POR. Writing a 0 has no effect.

Power Management 1 Status Register 2 (PM1_STS 2)

Register Location: <PM1_BLK>+1h System I/O Space

Default Value: 00h on Vbat POR

Attribute: Read/Write (Note 0)

Size: 8-bits

BIT	NAME	DESCRIPTION
0	PWRBTN_STS	This bit is set when the Button_In signal is asserted. In the system working state, while PWRBTN_EN and PWRBTN_STS are both set an SCI interrupt event is raised. In the sleeping or soft off state, a wake-up event is generated (regardless of the setting of PWRBTN_EN) (Note 2). This bit is only set by hardware and is reset by software writing a one to this bit position, and by Vbat POR. Writing a 0 has no effect. It is also reset as follows: If PWRBTNOR_EN is set, and if the Button_In signal is held asserted for more than four seconds, then this bit is cleared, the PWRBTNOR_STS bit is set and the system will transition into the soft off state (nPowerOn floats).
1	Reserved	Reserved.
2	RTC_STS	This bit is set when the RTC generates an alarm. Additionally if the RTC_EN bit is set then the setting of the RTC_STS bit will generate an SCI. When the AL_REM_EN bit is set in the RTC control register 1, then the RTC_STS bit is set due to an RTC alarm event occurring when Vtr is not present. This will indicate to the OS the cause of the wakeup event (nPowerOn pin asserted when Vtr returns) caused by the "alarm remember" logic in the Soft Power Management block. (Note 1)
3	PWRBTNOR_STS	This bit is set when the power switch over-ride function is set: If PWRBTNOR_EN is set, and if the Button_In signal is held asserted for more than four seconds. Hardware is also required to reset the PWRBTN_STS when issuing a power switch over-ride function.

BIT	NAME	DESCRIPTION
		(Note 1)
4-6	Reserved	Reserved. These bits always return a value of zero.
7	WAK_STS	This bit is set when the system is in the sleeping state and an enabled wakeup event occurs. This bit is set on the high-to-low transition of nPowerOn, if the WAK_CTRL bit in the sleep / wake configuration register (0xF0 in Logical Device A) is cleared. If the WAK_CTRL bit is set, then any enabled wakeup event will also set the WAK_STS bit in addition to the high-to-low transition of nPowerOn. It is cleared by writing a 1 to its bit location when nPowerOn is active (low). Upon setting this bit, the system will transition to the working state. (Note 1)

Note 1: This bit is set by hardware and can only be cleared by software writing a one to this bit position and by Vbat POR. Writing a 0 has no effect.

Note 2: In the present implementation of Button_In, pressing the button will always wake the machine (i.e., activate nPowerOn).

Power Management 1 Enable Register 1 (PM1_EN 1)

Register Location: <PM1_BLK>+2 System I/O Space

Default Value:00h on Vbat POR

Attribute:Read/Write (Note 0)

Size:8-bits

BIT	NAME	DESCRIPTION
0-7	Reserved	Reserved. These bits always return a value of zero.

Power Management 1 Enable Register 2 (PM1_EN 2)

Register Location: <PM1_BLK>+3 System I/O Space

Default Value:00h on Vbat POR

Attribute:Read/Write (Note 0)

Size:8-bits

BIT	NAME	DESCRIPTION
0	PWRBTN_EN	This bit is used to enable the assertion of the Button_In to generate an SCI event. The PWRBTN_STS bit is set anytime the Button_In signal is asserted. The enable bit does not have to be set to enable the setting of the PWRBTN_STS bit by the assertion of the Button_In signal.
1	Reserved	Reserved.
2	RTC_EN	This bit is used to enable the setting of the RTC_STS bit to generate an SCI. The RTC_STS bit is set anytime the RTC generates an alarm.
3-7	Reserved	Reserved. These bits always return a value of zero.

Power Management 1 Control Register 1 (PM1_CNTRL 1)

Register Location: <PM1_BLK>+4 System I/O Space

Default Value:00h on Vbat POR

Attribute:Read/Write (Note 0)

Size:8-bits

BIT	NAME	DESCRIPTION
0	SCI_EN	When this bit is set, then the SCI enabled power management events will

BIT	NAME	DESCRIPTION
		generate an SCI interrupt. When this bit is reset power management events will not generate an SCI interrupt.
1-7	Reserved	Reserved. These bits always return a value of zero.

Power Management 1 Control Register 2 (PM1_CNTRL 2)

Register Location: <PM1_BLK>+5 System I/O Space

Default Value:00h on Vbat POR

Attribute:Read/Write (Note 0)

Size:8-bits

BIT	NAME	DESCRIPTION
0	Reserved	Reserved. This field always returns zero.
1	PWRBTNOR_EN	This bit controls the power button over-ride function. When set, then anytime the Button_In signal is asserted for more than four seconds the system will transition to the off state. When a power button over-ride event occurs, the logic should clear the PWRBTN_STS bit, and set the PWRBTNOR_STS bit.
2-4	SLP_TYPx	This 3-bit field defines the type of hardware sleep state the system enters when the SLP_EN bit is set to one. When this field is 000 the FDC37B78x will transition the machine to the off state when the SLP_EN bit is set to one. That is, with this field set to 000, nPowerOn will go inactive (float) after a 1-2 RTC clock delay when SLP_EN is set. This delay is a minimum of one 32kHz clock and a maximum of two 32kHz clocks (31.25µsec-62.5µsec). When this field is any other value, there is no effect.
5	SLP_EN	This is a write-only bit and reads to it always return a zero. Writing '1' to this bit causes the system to sequence into the sleeping state associated with the SLP_TYPx fields after a 1-2 RTC clock delay, if the SLP_CTRL bit in the sleep / wake configuration register (0xF0 in Logical Device A) is cleared. If the SLP_CTRL bit is set, do not sequence into the sleeping state associated with the SLP_TYPx field, but generate an SMI. Note: the SLP_EN_SMI bit in the SMI Status Register 2 is always set upon writing '1' to the SLP_EN bit. Writing '0' to this bit has no effect.
6-7	Reserved	Reserved. This field always returns zero.

General Purpose Event Status Register 1 (GPE_STS1)

Register Location: <PM1_BLK>+8 System I/O Space

Default Value:00h on Vbat POR

Attribute:Read/Write (Note 0)

Size:8-bits

BIT	NAME	DESCRIPTION
0	SCI_STS1	This bit is set when the device power management events (PME events) occur. When enabled, the setting of this bit will generate an SCI Interrupt (Note 1). Writing a "1" to this bit will clear it if there are no pending PME events. See Figure 5.
1-7	Reserved	Reserved. These bits always return a value of zero.

Note 1: This bit is set by hardware and can only be cleared by software writing a one to this bit position and by Vbat POR. Writing a 0 has no effect.

General Purpose Event Enable Register 1 (GPE_EN1)

Register Location: <PM1_BLK>+9 System I/O Space

Default Value:00h on Vbat POR

Attribute:Read/Write (Note 0)

Size:8-bits

BIT	NAME	DESCRIPTION
0	SCI_EN1	When this bit is set, then the enabled device power management events (PME events) will generate an SCI interrupt. When this bit is reset, device power management events will not generate an SCI interrupt.
1-7	Reserved	Reserved. These bits always return a value of zero.

Note 0: all bits described as "reserved" in writeable registers must be written with the value 0 when the register is written.

PME Registers

The power management event function has a PME_Status bit and a PME_En bit. These bits are defined in the PCI Bus Power Management Interface Specification, Revision 1.0, Draft, Copyright © 1997, PCI Special Interest Group, Mar. 18, 1997.

The default states for the PME_Status and PME_En bits are controlled by V_{bat} Power-On-Reset.

PME Status Register (PME_STS)

Register Location: <PM1_BLK>+10h System I/O Space

Default Value:00h on Vbat POR

Attribute:Read/Write (Note 0)

Size:8-bits

D7	D6	D5	D4	D3	D2	D1	D0	DEFAULT
RESERVED							PME_Status	0x00

- The PME_Status bit is set when the FDC37B78x would normally assert the PCI nPME signal, independent of the state of the PME_En bit. Only active transitions on the PME Wake sources can set the PME_Status bit.

- The PME_Status bit is read/write-clear. Writing a “1” to the PME_Status bit will clear it (if there are no pending PME events) and cause the FDC37C78X to stop asserting the nPME, if enabled. See Figure 5.
- Writing a “0” has no effect on the PME_Status bit.
- The PME_Status bit is reset to “0” during VBAT Power-On-Reset.

PME Enable Register (PME_EN)

Register Location: <PM1_BLK>+11h System I/O Space

Default Value:00h on Vbat POR

Attribute:Read/Write (Note 0)

Size:8-bits

D7	D6	D5	D4	D3	D2	D1	D0	DEFAULT
RESERVED							PME_En	0x00

- Setting the PME_En bit to “1” enables the FDC37B78x to assert the nPME signal.
- When the PME_En bit is reset to “0”, nPME signal assertion is disabled.
- The PME_En bit is reset to “0” during VBAT Power-On-Reset.

PME Status Register 1 (PME_STS 1)

Register Location: <PM1_BLK>+Ch System I/O Space

Default Value:00h on Vbat POR

Attribute:Read/Write (Note 0)

Size:8-bits

D7	D6	D5	D4	D3	D2	D1	D0	DEFAULT
DEVINT_STS	RTC_PME_STS	nRING	MOUSE	KBD	RI1	RI2	CIR	0x00

PME Status Register 2 (PME_STS2)

Register Location: <PM1_BLK>+Dh System I/O Space

Default Value:00h on Vbat POR

Attribute:Read/Write (Note 0)

Size:8-bits

D7	D6	D5	D4	D3	D2	D1	D0	DEFAULT
GP17	GP16	GP15	GP14	GP13	GP12	GP11	GP10	0x00

- The PME Status registers indicate the state of the individual FDC37B78x PME wake sources, independent of the state of the individual source enables or the PME_En bit.
- If the wake source has asserted a wake event, the associated PME Status bit will be “1”. The wake source bits in the PME Status registers are read/write-clear: an active (“1”) PME Status bit can only be cleared by writing a “1” to the bit. Writing a “0” to bits in the PME Wake Status register has no effect.

PME Enable Register 1 (PME_EN1)

Register Location: <PM1_BLK>+Eh System I/O Space

Default Value:00h on Vbat POR

Attribute:Read/Write (Note 0)

Size:8-bits

D7	D6	D5	D4	D3	D2	D1	D0	DEFAULT
DEVINT_EN	RTC_PME_EN	nRING	MOUSE	KBD	R11	RI2	CIR	0x00

PME Enable Register 2 (PME_EN2)

Register Location: <PM1_BLK>+Fh System I/O Space

Default Value:00h on Vbat POR

Attribute:Read/Write (Note 0)

Size:8-bits

D7	D6	D5	D4	D3	D2	D1	D0	DEFAULT
GP17	GP16	GP15	GP14	GP13	GP12	GP11	GP10	0x00

- The PME Enable registers enable the individual FDC37B78x wake sources onto the nPME bus.
- When the PME Enable register bit for a wake source is active ("1"), if the source asserts a wake event and the PME_En bit is "1", the source will assert the PCI nPME signal.
- When the PME Enable register bit for a wake source is inactive ("0"), the PME Status register will indicate the state of the wake source but will not assert the PCI nPME signal.

SMI Registers

The FDC37B78x implements a group nSMI output pin. The nSMI group interrupt output consists of the enabled interrupts from each of the functional blocks in the chip plus other SMI events. The interrupts are enabled onto the group nSMI output via the SMI Enable Registers 1 and 2. The nSMI output is then enabled onto the group nSMI output pin or Serial IRQ Frame (IRQ2) via bit[7] in the SMI Enable Register 2. These SMI events can also be enabled as nPME/SCI events by setting the EN_SMI_PME bit, bit[6] of SMI Enable Register 2.

This register is also used to enable the group nSMI output onto the nSMI Serial/Parallel IRQ pin and the routing of 8042 P12 internally to nSMI.

The IRQ mux Register Bit 7 is used to select the SMI on the SMI pin or the Serial IRQ frame.

SMI Status Register 1 (SMI_STS1)

Register Location: <PM1_BLK>+12h System I/O Space

Default Value:00h on Vbat POR

Attribute:Read/Write

Size:8-bits

NAME	DESCRIPTION
SMI Status Register 1 Default = 0x00 on Vbat POR	This register is used to read the status of the SMI inputs. The following bits must be cleared at their source. Bit[0] Reserved Bit[1] PINT (Parallel Port Interrupt) Bit[2] U2INT (UART 2 Interrupt) Bit[3] U1INT (UART 1 Interrupt) Bit[4] FINT (Floppy Disk Controller Interrupt) Bit[5] GPINT2 (Group Interrupt 2) Bit[6] GPINT1 (Group Interrupt 1) Bit[7] WDT (Watch Dog Timer)

SMI Status Register 2 (SMI_STS2)

Register Location: <PM1_BLK>+13h System I/O Space

Default Value:00h on Vbat POR

Attribute:Read/Write

Size:8-bits

NAME	DESCRIPTION
SMI Status Register 2 Default = 0x00 on Vbat POR	This register is used to read the status of the SMI inputs. Bit[0] MINT: Mouse Interrupt. Cleared at source. Bit[1] KINT: Keyboard Interrupt. Cleared at source. Bit[2] IRINT: This bit is set by a transition on the IR pin (RXD2 or IRRX2 as selected by Bit 6 of Configuration Register 0xF1 in Logical Device 5, i.e., after the MUX). Cleared by a read of this register. Bit[3] BINT: Cleared by a read of this register. Bit[4] P12: 8042 P1.2. Cleared at source Bits[5:6] Reserved Bit[7] SLP_EN_SMI. The SLP_EN SMI status bit. Cleared by a read of this register. (See Sleep Enable Config Reg.) 0=no SMI due to setting SLP_EN bit 1=SMI generated due to setting SLP_EN bit.

SMI Enable Register 1 (SMI_EN1)

Register Location: < PM1_BLK >+14h System I/O Space

Default Value:00h on Vbat POR

Attribute:Read/Write

Size:8-bits

NAME	DESCRIPTION
SMI Enable Register 1 Default = 0x00 on Vbat POR	This register is used to enable the different interrupt sources onto the group nSMI output. 1=Enable 0=Disable Bit[0] EN_RING Note: the PME status bit for RING is used as the SMI status bit for RING (see PME Status Register). Bit[1] EN_PINT Bit[2] EN_U2INT Bit[3] EN_U1INT Bit[4] EN_FINT Bit[5] EN_GPINT2 Bit[6] EN_GPINT1 Bit[7] EN_WDT

SMI Enable Register 2 (SMI_EN2)

Register Location: < PM1_BLK >+15h System I/O Space

Default Value:00h on Vbat POR

Attribute:Read/Write

Size:8-bits

NAME	DESCRIPTION
SMI Enable Register 2 Default = 0x00 on Vbat POR	This register is used to enable the different interrupt sources onto the group nSMI output, and the group nSMI output onto the nSMI GPI/O pin. Unless otherwise noted, 1=Enable 0=Disable Bit[0] EN_MINT Bit[1] EN_KINT Bit[2] EN_IRINT Bit[3] EN_BINT Bit[4] EN_P12: Enable 8042 P1.2 to route internally to nSMI 0=Do not route to nSMI 1=Enable routing to nSMI. Bit [5] EN_CIR Note: the PME status bit for CIR is used as the SMI status bit for CIR (see PME Status Register). Bit[6] EN_SMI_PME: Enable the group nSMI output into the PME interface logic. 0= Group SMI output does not go to PME interface logic 1= Enable group SMI output to PME interface logic Bit[7] EN_SMI: Enable the group nSMI output onto the nSMI pin or Serial IRQ frame (IRQ2). 0=SMI pin floats 1=Enable group nSMI output onto nSMI pin or serial IRQ frame Note: the selection of either the nSMI pin or serial IRQ frame is done via bit 7 of the IRQ Mux Control Register (0xC0 in Logical Device 8).

EITHER EDGE TRIGGERED INTERRUPTS

Four GPIO pins are implemented that allow an interrupt to be generated on both a high-to-low and a low-to-high edge transition, instead of one or the other as selected by the polarity bit.

The either edge triggered interrupts function as follows: Selecting the Either Edge Triggered Interrupt (EETI) function for these GPIO pins is applicable when the combined interrupt is enabled for the GPIO pin (GPINT1 for GP10-GP17, and GPINT2 for GP50-GP54 and GP60-GP67). Otherwise, selection of the EETI function will produce no function for the pin. If the EETI

function is selected for the GPIO pin, then the bits that control input/output, polarity and open collector/push-pull have no effect on the function of the pin. However, the polarity bit does affect the value of the GP bit (i.e., register GP1, bit 2 for GP12).

An interrupt occurs if the status bit is set and the interrupt is enabled. The status bits indicate which of the EETI interrupts transitioned. These status bits are located in the MSC_STS register. The status is valid whether or not the interrupt is enabled and whether or not the EETI function is selected for the pin.

Miscellaneous Status Register

The MSC_STS register is implemented as follows to hold the status bits of these four GPIOs.

Miscellaneous Status Register (PM1_STS)
 Register Location: <PM1_BLK>+16h System I/O Space
 Default Value: 00h on Vbat POR
 Attribute: Read/Write (Note 0)
 Size: 8-bits

BIT	NAME	DEFINITION
0	EETI1_STS	Either Edge Triggered Interrupt Input 1 Status. This bit is set when an edge occurs on the GP11 pin. This bit is cleared by writing a 1 to this bit position (writing a 0 has no effect).
1	EETI2_STS	Either Edge Triggered Interrupt Input 2 Status. This bit is set when an edge occurs on the GP12 pin. This bit is cleared by writing a 1 to this bit position (writing a 0 has no effect).
2	EETI3_STS	Either Edge Triggered Interrupt Input 3 Status. This bit is set when an edge occurs on the GP53 pin. This bit is cleared by writing a 1 to this bit position (writing a 0 has no effect).
3	EETI4_STS	Either Edge Triggered Interrupt Input 4 Status. This bit is set when an edge occurs on the GP54 pin. This bit is cleared by writing a 1 to this bit position (writing a 0 has no effect).
4	VTRPOR_STS	This bit is set upon VTR POR. This bit is cleared by writing a 1 to this bit position (writing a 0 has no effect). Additionally, when the system turns on (nPowerOn active low) due to a VTR POR, then an SCI is generated.
5-7	Reserved	Reserved. This bit always returns zero.

SMI/PME/SCI Logic

The logic for the SMI, PME and SCI signals is shown in the figures that follow.

FIGURE 5 - PME/SCI LOGIC

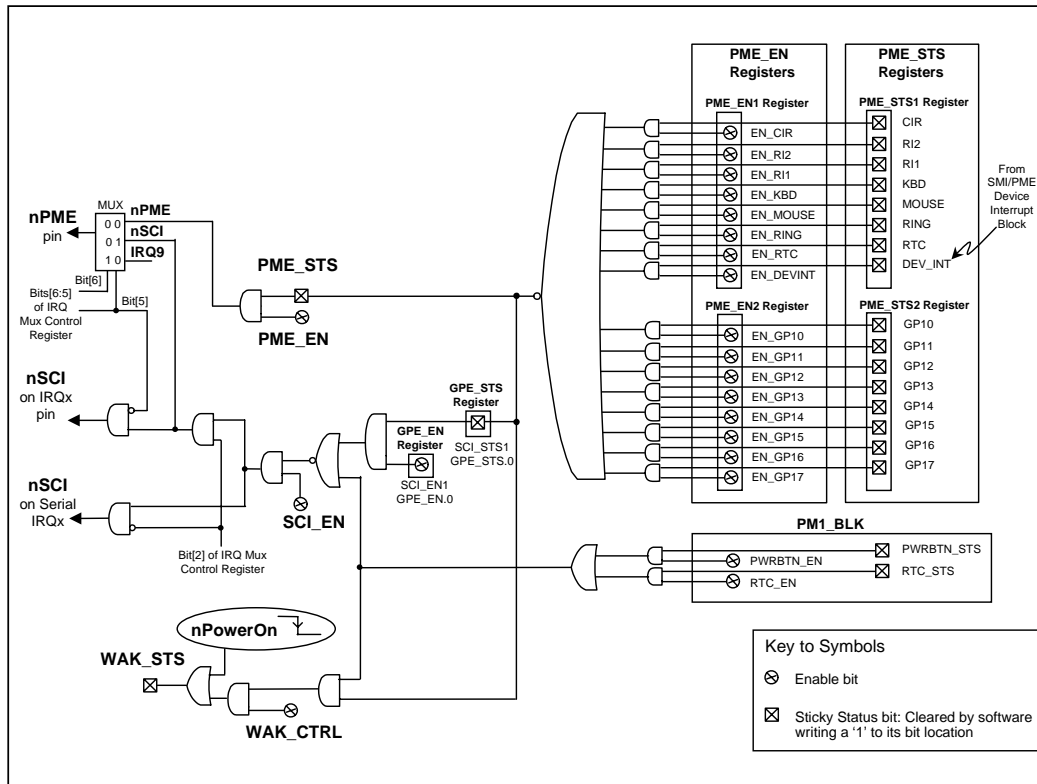
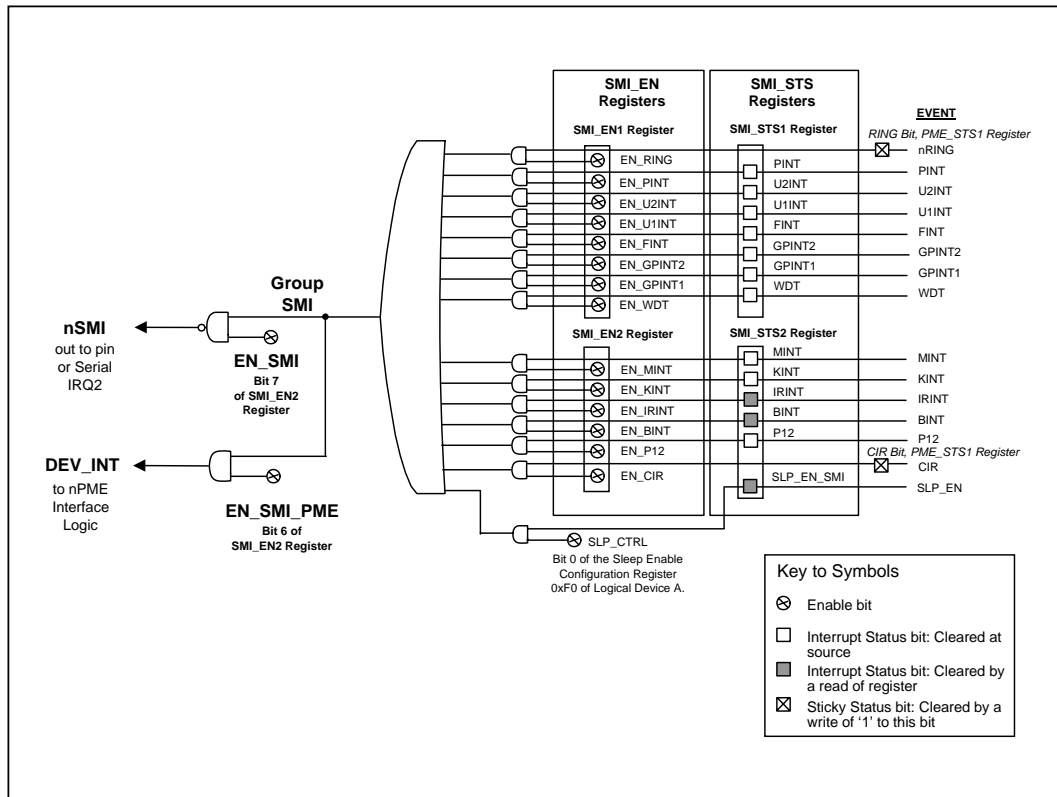

FIGURE 6 - SMI/PME LOGIC



PORT NAME	SYSOPT= 0 (Pull-down resistor) Refer to Note 1	SYSOPT= 1 (10K Pull-up resistor)	TYPE
CONFIG PORT (Note 2)	0x03F0	0x0370	Write
INDEX PORT (Note 2)	0x03F0	0x0370	Read/Write
DATA PORT	INDEX PORT + 1		Read/Write

Note 1: If using TTL RS232 drivers use 1K pull-down. If using CMOS RS232 drivers use 10K pull-down.
 Note 2: The configuration port base address can be relocated through CR26 and CR27.

Entering the Configuration State

The device enters the Configuration State when the following Config Key is successfully written to the CONFIG PORT.

Config Key = < 0x55>

When in configuration mode, all logical devices function properly. Entering and exiting configuration mode has no effect on the devices.

Exiting the Configuration State

The device exits the Configuration State when the following Config Key is successfully written to the CONFIG PORT.

Config Key = < 0xAA>

CONFIGURATION SEQUENCE

To program the configuration registers, the following sequence must be followed:

1. Enter Configuration Mode
2. Configure the Configuration Registers
3. Exit Configuration Mode.

Enter Configuration Mode

To place the chip into the Configuration State the Config Key is sent to the chip's CONFIG PORT. The config key consists of a write of 0x55 data to the CONFIG PORT. Once the initiation key is received correctly the chip enters into the Configuration State (The auto Config ports are enabled).

Configuration Mode

The system sets the logical device information and activates desired logical devices through the INDEX and DATA ports. In configuration mode, the INDEX PORT is located at the CONFIG PORT address and the DATA PORT is at INDEX PORT address + 1.

The desired configuration registers are accessed in two steps:

- a. Write the index of the Logical Device Number Configuration Register (i.e., 0x07) to the INDEX PORT and then write the number of the desired logical device to the DATA PORT.
- b. Write the address of the desired configuration register within the logical device to the INDEX PORT and then write or read the configuration register through the DATA PORT.

Note: if accessing the Global Configuration Registers, step (a) is not required.

Exit Configuration Mode

To exit the Configuration State the system writes 0xAA to the CONFIG PORT. The chip returns to the RUN State.

Note: Only two states are defined (Run and Configuration). In the Run State the chip will always be ready to enter the Configuration State.

Programming Example

The following is an example of a configuration program in Intel 8086 assembly language.

```
;-----  
; ENTER CONFIGURATION MODE  
;-----  
MOV DX,3F0H  
MOV AX,055H  
CLI; disable interrupts  
OUT DX,AL  
STI; enable interrupts  
;-----  
; CONFIGURE REGISTER CRE0,  
; LOGICAL DEVICE 8  
;-----  
MOV DX,3F0H  
MOV AL,07H  
OUT DX,AL ; Point to LD# Config Reg  
MOV DX,3F1H  
MOV AL, 08H  
OUT DX,AL ; Point to Logical Device 8  
;  
MOV DX,3F0H  
MOV AL,E0H  
OUT DX,AL; Point to CRE0  
MOV DX,3F1H  
MOV AL,02H  
OUT DX,AL; Update CRE0  
;-----  
; EXIT CONFIGURATION MODE  
;-----  
MOV DX,3F0H  
MOV AX,0AAH  
OUT DX,AL
```

- Notes: 1. HARD RESET: RESET_DRV pin asserted
2. SOFT RESET: Bit 0 of Configuration Control register set to one
3. All host accesses are blocked for 500µs after Vcc POR (see Power-up Timing Diagram)

CONFIGURATION REGISTERS

INDEX	TYPE	HARD RESET	Vcc POR	Vtr POR	Vbat POR	SOFT RESET	CONFIGURATION REGISTER
GLOBAL CONFIGURATION REGISTERS							
0x02	W	0x00	0x00	0x00	-	-	Config Control
0x03	R/W	0x03	0x03	0x03	-	-	Index Address
0x07	R/W	0x00	0x00	0x00	-	0x00	Logical Device Number
0x20	R	0x44	0x44	0x44	-	0x44	Device ID - hard wired
0x21	R	0x00	0x00	0x00	-	0x00	Device Rev - hard wired
0x22	R/W	0x00 ^(Note 0)	0x00 ^(Note 0)	0x00 ^(Note 0)	-	0x00 ^(Note 0)	Power Control
0x23	R/W	0x00	0x00	0x00	-	-	Power Mgmt
0x24	R/W	0x04	0x04	0x04	-	-	OSC
0x26	R/W	Sysopt=0: 0xF0 Sysopt=1: 0x70	Sysopt=0: 0xF0 Sysopt=1: 0x70	-	-	-	Configuration Port Address Byte 0
0x27	R/W	Sysopt=0: 0x03 Sysopt=1: 0x03	Sysopt=0: 0x03 Sysopt=1: 0x03	-	-	-	Configuration Port Address Byte 1
0x28	R/W	0x00	0x00	-	-	0x00	Clock Mask Register
0x2B	R/W	-	0x00	0x00	-	-	TEST 4
0x2C	R/W	-	0x00	0x00	-	-	TEST 5
0x2D	R/W	-	0x00	0x00	-	-	TEST 1
0x2E	R/W	-	0x00	0x00	-	-	TEST 2
0x2F	R/W	-	0x00	0x00	-	-	TEST 3
LOGICAL DEVICE 0 CONFIGURATION REGISTERS (FDD)							
0x30	R/W	0x00	0x00	0x00	-	0x00	Activate
0x60, 0x61	R/W	0x03, 0xF0	0x03, 0xF0	0x03, 0xF0	-	0x03, 0xF0	Primary Base I/O Address
0x70	R/W	0x06	0x06	0x06	-	0x06	Primary Interrupt Select
0x74	R/W	0x02	0x02	0x02	-	0x02	DMA Channel Select
0xF0	R/W	0x0E	0x0E	0x0E	-	-	FDD Mode Register
0xF1	R/W	0x00	0x00	0x00	-	-	FDD Option Register
0xF2	R/W	0xFF	0xFF	0xFF	-	-	FDD Type Register
0xF4	R/W	0x00	0x00	0x00	-	-	FDD0
0xF5	R/W	0x00	0x00	0x00	-	-	FDD1
LOGICAL DEVICE 1 CONFIGURATION REGISTERS (Reserved)							
LOGICAL DEVICE 2 CONFIGURATION REGISTERS (Reserved)							
LOGICAL DEVICE 3 CONFIGURATION REGISTERS (Parallel Port)							

INDEX	TYPE	HARD RESET	Vcc POR	Vtr POR	Vbat POR	SOFT RESET	CONFIGURATION REGISTER
0x30	R/W	0x00	0x00	0x00	-	0x00	Activate
0x60, 0x61	R/W	0x00, 0x00	0x00, 0x00	0x00, 0x00	-	0x00, 0x00	Primary Base I/O Address
0x70	R/W	0x00	0x00	0x00	-	0x00	Primary Interrupt Select
0x74	R/W	0x04	0x04	0x04	-	0x04	DMA Channel Select
0xF0	R/W	0x3C	0x3C	0x3C	-	-	Parallel Port Mode Register
0xF1	R/W	0x00	0x00	0x00	-	-	Parallel Port Mode Register 2
LOGICAL DEVICE 4 CONFIGURATION REGISTERS (Serial Port 1)							
0x30	R/W	0x00	0x00	0x00	-	0x00	Activate
0x60, 0x61	R/W	0x00, 0x00	0x00, 0x00	0x00, 0x00	-	0x00, 0x00	Primary Base I/O Address
0x70	R/W	0x00	0x00	0x00	-	0x00	Primary Interrupt Select
0xF0	R/W	0x00	0x00	0x00	-	-	Serial Port 1 Mode Register
LOGICAL DEVICE 5 CONFIGURATION REGISTERS (Serial Port 2)							
0x30	R/W	-	-	0x00	-	-	Activate
0x60, 0x61	R/W	0x00, 0x00	0x00, 0x00	0x00, 0x00	-	0x00, 0x00	Primary Base I/O Address
0x62, 0x63	R/W	0x00, 0x00	0x00, 0x00	0x00, 0x00	-	0x00, 0x00	CIR Base I/O Address
0x70	R/W	0x00	0x00	0x00	-	0x00	Primary Interrupt Select
0x74	R/W	0x04	0x04	0x04	-	0x04	DMA Channel Select
0xF0	R/W	0x00	0x00	0x00	-	-	Serial Port 2 Mode Register
0xF1	R/W	0x02	0x02	0x02	-	-	IR Options Register
0xF2	R/W	0x03	0x03	0x03	-	-	IR Half Duplex Timeout
LOGICAL DEVICE 6 CONFIGURATION REGISTERS (RTC)							
0x30	R/W	0x00	0x00	0x00	-	0x00	Activate
0x62, 0x63	R/W	0x00, 0x70	0x00, 0x70	0x00, 0x70	-	0x00, 0x70	Secondary Base Address for RTC Bank 1
0x70	R/W	0x00	0x00	0x00	-	0x00	Primary Interrupt Select
0xF0	R/W	0x00	0x00	n/a	-	n/a	Real Time Clock Mode Register
LOGICAL DEVICE 7 CONFIGURATION REGISTERS (Keyboard)							
0x30	R/W	0x00	0x00	0x00	-	0x00	Activate
0x70	R/W	0x00	0x00	0x00	-	0x00	Primary Interrupt Select
0x72	R/W	0x00	0x00	0x00	-	0x00	Second Interrupt Select
0xF0	R/W	0x00	0x00	0x00	-	-	KRESET and GateA20 Select

INDEX	TYPE	HARD RESET	Vcc POR	Vtr POR	Vbat POR	SOFT RESET	CONFIGURATION REGISTER
LOGICAL DEVICE 8 CONFIGURATION REGISTERS (Aux I/O)							
0x30	R/W	0x00	0x00	0x00	-	0x00	Activate
0xB0	R/W	-	-	-	0x00	-	Soft Power Enable Register 1 ³
0xB1	R/W	-	-	-	0x80	-	Soft Power Enable Register 2 ³
0xB2	R/W	-	-	-	0x00	-	Soft Power Status Register 1 ³
0xB3	R/W	-	-	-	0x00	-	Soft Power Status Register 2 ³
0xB8	R/W	-	-	0x00	-	-	Delay 2 Time Set Register
0xC0	R/W	-	-	-	0x00	-	IRQ Mux Control ³
0xC1	R/W	0x01	0x01	-	-	-	Force Disk Change
0xC2	R	-	-	-	-	-	Floppy Data Rate Select Shadow
0xC3	R	-	-	-	-	-	UART1 FIFO Control Shadow
0xC4	R	-	-	-	-	-	UART2 FIFO Control Shadow
0xC5	R/W	0x00	0x00	-	-	-	FDC Force Write Protect
0xC6	R/W	-	-	-	0x00	-	Ring Filter Select ³
0xC8	R/W	-	-	-	0x01	-	GP50 ³
0xCA	R/W	-	-	-	0x09	-	GP52 ³
0xCB	R/W	-	-	-	0x01	-	GP53 ³
0xCC	R/W	-	-	-	0x01	-	GP54 ³
0xD0	R/W	-	-	-	0x01	-	GP60 ³
0xD1	R/W	-	-	-	0x01	-	GP61 ³
0xD2	R/W	-	-	-	0x01	-	GP62 ³
0xD3	R/W	-	-	-	0x01	-	GP63 ³
0xD4	R/W	-	-	-	0x01	-	GP64 ³
0xD5	R/W	-	-	-	0x01	-	GP65 ³
0xD6	R/W	-	-	-	0x01	-	GP66 ³
0xD7	R/W	-	-	-	0x01	-	GP67 ³
0xE0	R/W	-	-	-	0x01	-	GP10 ³
0xE1	R/W	-	-	-	0x01	-	GP11 ³
0xE2	R/W	-	-	-	0x01	-	GP12 ³
0xE3	R/W	-	-	-	0x01	-	GP13 ³
0xE4	R/W	-	-	-	0x01	-	GP14 ³

INDEX	TYPE	HARD RESET	Vcc POR	Vtr POR	Vbat POR	SOFT RESET	CONFIGURATION REGISTER
0xE5	R/W	-	-	-	0x00	-	GP15 ³
0xE6	R/W	-	-	-	0x01	-	GP16 ³
0xE7	R/W	-	-	-	0x01	-	GP17 ³
0xEF	R/W	-	-	-	0x00	-	GP_INT2 ³
0xF0	R/W	-	-	-	0x00	-	GP_INT1 ³
0xF1	R/W	0x00	0x00	0x00	-	-	WDT_UNITS
0xF2	R/W	0x00	0x00	0x00	-	-	WDT_VAL
0xF3	R/W	0x00	0x00	0x00	-	-	WDT_CFG
0xF4	R/W ⁽¹⁾	0x00	0x00	0x00	-	-	WDT_CTRL
0xF6	R/W	-	-	-	0x00	-	GP1 ³
0xF9	R/W	-	-	-	0x00	-	GP5 ³
0xFA	R/W	-	-	-	0x00	-	GP6 ³
LOGICAL DEVICE A CONFIGURATION REGISTERS (ACPI)							
0x30	R/W	0x00	0x00	0x00	-	0x00	Activate ⁴
0x60, 0x61 ⁽²⁾	R/W	0x00, 0x00	0x00, 0x00	0x00, 0x00	-	0x00, 0x00	Primary Base I/O Address PM1_BLK
0x70	R/W	-	-	-	0x00	-	Primary Interrupt Select ³
0xF0	R/W	-	-	-	0x00	-	Sleep/Wake Configuration ³

Notes

- 0) CR22 Bit 5 is reset on Vtr POR only
- 1) This register contains some bits which are read or write only.
- 2) Register 60 is the high byte; 61 is the low byte. For example to set the primary base address to 1234h, write 12h into 60, and 34h into 61.
- 3) These configuration registers are powered by Vtr and battery backed up.
- 4) The Activate bit for Logical Device A does not effect the generation of an interrupt (SCI).

Chip Level (Global) Control/Configuration Registers [0x00-0x2F]

The chip-level (global) registers lie in the address range [0x00-0x2F]. The design MUST use all 8 bits of the ADDRESS Port for register selection. All unimplemented registers and bits ignore writes and return zero when read. The INDEX PORT is used to select a configuration register in the chip. The DATA PORT is then used to access the selected register. These registers are accessible only in the Configuration Mode.

TABLE 71 - CHIP LEVEL REGISTERS

REGISTER	ADDRESS	DESCRIPTION	STATE
Chip (Global) Control Registers			
	0x00 - 0x01	Reserved - Writes are ignored, reads return 0.	
Config Control Default = 0x00 on Vcc POR or Reset_Drv	0x02 W	The hardware automatically clears this bit after the write, there is no need for software to clear the bits. Bit 0 = 1: Soft Reset. Refer to the "Configuration Registers" table for the soft reset value for each register.	C
Index Address Default = 0x03 on Vcc POR or Reset_Drv	0x03 R/W	Bit[7] = 1 Enable GP1, WDT_CTRL, GP5, GP6, Soft Power Enable and Status Register access when not in configuration mode = 0 Disable GP1, WDT_CTRL, GP5, GP6, Soft Power Enable and Status Register access when not in configuration mode (Default) Bits [6:2] Reserved - Writes are ignored, reads return 0. Bits[1:0] Sets GP1 etc. selection register used when in Run mode (not in Configuration Mode). = 11 0xEA (Default) = 10 0xE4 = 01 0xE2 = 00 0xE0	
	0x04 - 0x06	Reserved - Writes are ignored, reads return 0.	
Logical Device # Default = 0x00 on Vcc POR or Reset_Drv	0x07 R/W	A write to this register selects the current logical device. This allows access to the control and configuration registers for each logical device. Note: the Activate command operates only on the selected logical device.	C
Card Level Reserved	0x08 - 0x1F	Reserved - Writes are ignored, reads return 0.	
Chip Level, SMSC Defined			

REGISTER	ADDRESS	DESCRIPTION	STATE
Device ID Hard wired = 0x44	0x20 R	A read only register which provides device identification. Bits[7:0] = 0x44 when read	C
Device Rev Hard wired = 0x00	0x21 R	A read only register which provides device revision information. Bits[7:0] = 0x00 when read	C
PowerControl Default = 0x00. on Vcc POR or Reset_Drv hardware signal.	0x22 R/W	Bit[0] FDC Power Bit[1] Reserved Bit[2] Reserved Bit[3] Parallel Port Power Bit[4] Serial Port 1 Power Bit[5] Serial Port 2 Power Bit[6] Reserved Bit[7] Reserved = 0 Power off or disabled = 1 Power on or enabled	C
Power Mgmt Default = 0x00. on Vcc POR or Reset_Drv hardware signal	0x23 R/W	Bit[0] FDC Bit[1] Reserved Bit[2] Reserved Bit[3] Parallel Port Bit[4] Serial Port 1 Bit[5] Serial Port 2 Bit[6] Reserved (read as 0) Bit[7] Reserved (read as 0) = 0 Intelligent Pwr Mgmt off = 1 Intelligent Pwr Mgmt on	C
OSC Default = 0x04, on Vcc POR or Reset_Drv hardware signal.	0x24 R/W	Bit[0] Reserved Bit [1] PLL Control = 0 PLL is on (backward Compatible) = 1 PLL is off Bits[3:2] OSC = 01 Osc is on, BRG clock is on. = 10 Same as above (01) case. = 00 Osc is on, BRG Clock Enabled. = 11 Osc is off, BRG clock is disabled. Bit [6:4] Reserved, set to zero Bit[7] IRQ8 Polarity = 0 IRQ8 is active high = 1 IRQ8 is active low	C
Chip Level Vendor Defined	0x25	Reserved - Writes are ignored, reads return 0.	

REGISTER	ADDRESS	DESCRIPTION	STATE
Configuration Address Byte 0 Default=0xF0 (Sysopt=0) =0x70 (Sysopt=1) on Vcc POR or Reset_Drv	0x26	Bit[7:1] Configuration Address Bits [7:1] Bit[0] = 0 See Note 1 Below	C
Configuration Address Byte 1 Default = 0x03 on Vcc POR or Reset_Drv	0x27	Bit[7:0] Configuration Address Bits [15:8] See Note 1 Below	C
Chip Level Vendor Defined	0x28 -0x2A	Reserved - Writes are ignored, reads return 0.	
TEST 4	0x2B R/W	Test Modes: Reserved for SMSC. Users should not write to this register, may produce undesired results.	C
TEST 5	0x2C R/W	Test Modes: Reserved for SMSC. Users should not write to this register, may produce undesired results.	C
TEST 1	0x2D R/W	Test Modes: Reserved for SMSC. Users should not write to this register, may produce undesired results.	C
TEST 2	0x2E R/W	Test Modes: Reserved for SMSC. Users should not write to this register, may produce undesired results.	C
TEST 3 Default = 0x00, on Vcc POR or Reset_Drv hardware signal.	0x2F R/W	Test Modes: Reserved for SMSC. Users should not write to this register, may produce undesired results.	C

Note 1: To allow the selection of the configuration address to a user defined location, these Configuration Address Bytes are used. There is no restriction on the address chosen, except that A0 is 0, that is, the address must be on an even byte boundary. As soon as both bytes are changed, the configuration space is moved to the specified location with no delay (Note: Write byte 0, then byte 1; writing CR27 changes the base address).

The configuration address is only reset to its default address upon a Hard Reset or Vcc POR.
Note: the default configuration address is either 3F0 or 370, as specified by the SYSOPT pin.

This change affects SMSC Mode only.

Logical Device Configuration/Control Registers [0x30-0xFF]

Used to access the registers that are assigned to each logical unit. This chip supports eight logical units and has eight sets of logical device registers. The eight logical devices are Floppy, Parallel Port, Serial Port 1 and Serial Port 2, Real Time Clock, Keyboard Controller, Auxiliary I/O and ACPI. A separate set (bank) of control and configuration register exists for each logical device and is selected with the Logical Device # Register (0x07).

The INDEX PORT is used to select a specific logical device register. These registers are then accessed through the DATA PORT.

The Logical Device registers are accessible only when the device is in the Configuration State. The logical register addresses are:

Logical Device Registers

TABLE 72 - CHIP LEVEL REGISTERS

LOGICAL DEVICE REGISTER	ADDRESS	DESCRIPTION	STATE
Activate ^{Note1} Default = 0x00 on Vcc POR or Reset_Drv ^{Note 2}	(0x30)	Bits[7:1] Reserved, set to zero. Bit[0] = 1 Activates the logical device currently selected through the Logical Device # register. = 0 Logical device currently selected is inactive	C
Logical Device Control	(0x31-0x37)	Reserved - Writes are ignored, reads return 0.	C
Logical Device Control	(0x38-0x3f)	Vendor Defined - Reserved - Writes are ignored, reads return 0.	C
Mem Base Addr	(0x40-0x5F)	Reserved - Writes are ignored, reads return 0.	C
I/O Base Addr. (see Device Base I/O Address Table) Default = 0x00 on Vcc POR or Reset_Drv	(0x60-0x6F) 0x60,2,... = addr[15:8] 0x61,3,... = addr[7:0]	Registers 0x60 and 0x61 set the base address for the device. If more than one base address is required, the second base address is set by registers 0x62 and 0x63. Unused registers will ignore writes and return zero when read.	C
Interrupt Select Defaults : 0x70 = 0x00, on Vcc POR or Reset_Drv 0x72 = 0x00, on Vcc POR or Reset_Drv	(0x70,072)	0x70 is implemented for each logical device. Refer to Interrupt Configuration Register description. Only the keyboard controller uses Interrupt Select register 0x72. Unused register (0x72) will ignore writes and return zero when read. Interrupts default to edge high (ISA compatible).	C

LOGICAL DEVICE REGISTER	ADDRESS (0x71,0x73)	DESCRIPTION	STATE
		Reserved - not implemented. These register locations ignore writes and return zero when read.	
DMA Channel Select Default = 0x04 on Vcc POR or Reset_Drv	(0x74,0x75)	Only 0x74 is implemented for FDC, Serial Port 2 and Parallel port. 0x75 is not implemented and ignores writes and returns zero when read. Refer to DMA Channel Configuration.	C
32-Bit Memory Space Configuration	(0x76-0xA8)	Reserved - not implemented. These register locations ignore writes and return zero when read.	
Logical Device	(0xA9-0xDF)	Reserved - not implemented. These register locations ignore writes and return zero when read.	C
Logical Device Config.	(0xE0-0xFE)	Reserved - Vendor Defined (see SMSC defined Logical Device Configuration Registers)	C
Reserved	0xFF	Reserved	C

Note 1: A logical device will be active and powered up according to the following equation:

DEVICE ON (ACTIVE) = (Activate Bit SET or Pwr/Control Bit SET).

The Logical device's Activate Bit and its Pwr/Control Bit are linked such that setting or clearing one sets or clears the other.

Note: If the I/O Base Addr of the logical device is not within the Base I/O range as shown in the Logical Device I/O map, then read or write is not valid and is ignored.

Note 2. The activate bit for Logical Device 5 (Serial Port 2) is reset on Vtr POR only.

I/O Base Address Configuration Register

TABLE 73 - I/O BASE ADDRESS CONFIGURATION REGISTER DESCRIPTION

LOGICAL DEVICE NUMBER	LOGICAL DEVICE	REGISTER INDEX	BASE I/O RANGE (NOTE3)	FIXED BASE OFFSETS
0x00	FDC (Note 4)	0x60,0x61	[0x100:0x0FF8] ON 8 BYTE BOUNDARIES	+0 : SRA +1 : SRB +2 : DOR +3 : TSR +4 : MSR/DSR +5 : FIFO +7 : DIR/CCR
0x03	Parallel Port	0x60,0x61	[0x100:0x0FFC] ON 4 BYTE BOUNDARIES (EPP Not supported) or [0x100:0x0FF8] ON 8 BYTE BOUNDARIES (all modes supported, EPP is only available when the base address is on an 8- byte boundary)	+0 : Data ecpAfifo +1 : Status +2 : Control +3 : EPP Address +4 : EPP Data 0 +5 : EPP Data 1 +6 : EPP Data 2 +7 : EPP Data 3 +400h : cfifo ecpDfifo tfifo cnfgA +401h : cnfgB +402h : ecr
0x04	Serial Port 1	0x60,0x61	[0x100:0x0FF8] ON 8 BYTE BOUNDARIES	+0 : RB/TB LSB div +1 : IER MSB div +2 : IIR/FCR +3 : LCR +4 : MSR +5 : LSR +6 : MSR +7 : SCR
0x05	Serial Port 2	0x60,0x61	[0x100:0x0FF8] ON 8 BYTE BOUNDARIES	+0 : RB/TB LSB div +1 : IER MSB div +2 : IIR/FCR +3 : LCR +4 : MSR +5 : LSR +6 : MSR +7 : SCR

LOGICAL DEVICE NUMBER	LOGICAL DEVICE	REGISTER INDEX	BASE I/O RANGE (NOTE3)	FIXED BASE OFFSETS
		0x62,0x63	[0x100:0x0FF8] ON 8 BYTE BOUNDARIES	+0 : CIR Registers +1 : CIR Registers +2 : CIR Registers +3 : CIR Registers +4 : CIR Registers +5 : CIR Registers +6 : CIR Registers +7 : CIR Registers
0x06	RTC	n/a	Not Relocatable Fixed Base Address: 70,71	+0: Index Register +1: Data Register
		0x62, 0x63	[0x00:0xFFE] ON 2 BYTE BOUNDARIES	+0: Index Register +1: Data Register
0x07	KYBD	n/a	Not Relocatable Fixed Base Address: 60,64	+0 : Data Register +4 : Command/Status Reg.
0x0A	ACPI	0x60,0x61	[0x00:0x0FE7] ON 24 BYTE BOUNDARIES	

Note 3: This chip uses ISA address bits [A11:A0] to decode the base address of each of its logical devices.

Interrupt Select Configuration Register

TABLE 74 - INTERRUPT SELECT CONFIGURATION REGISTER DESCRIPTION

NAME	REG INDEX	DEFINITION	STATE
Interrupt Request Level Select 0 Default = 0x00 on Vcc POR or Reset_Drv	0x70 (R/W)	Bits[3:0] selects which interrupt level is used for Interrupt 0. 0x00=no interrupt selected. 0x01=IRQ1 0x02=IRQ2 • • • 0x0E=IRQ14 0x0F=IRQ15 Note: All interrupts are edge high (except ECP/EPP)	C

Note: It is the responsibility of the software to ensure that two IRQ's are not set to the same IRQ number.

Note: An Interrupt is activated by setting the Interrupt Request Level Select 0 register to a non-zero value **AND**:

- for the FDC logical device by setting DMAEN, bit D3 of the Digital Output Register.
- for the PP logical device by setting IRQE, bit D4 of the Control Port and in addition for the PP logical device in ECP mode by clearing serviceIntr, bit D2 of the ecr.
- for the Serial Port logical device by setting any combination of bits D0-D3 in the IER and by setting the OUT2 bit in the UART's Modem Control (MCR) Register.
- for the RTC by (refer to the RTC section of this spec.)
- for the KYBD by (refer to the KYBD controller section of this spec.)

Note: IRQ pins must tri-state if not used/selected by any Logical Device. Refer to Note A.

DMA Channel Select Configuration Register

TABLE 75 - DMA CHANNEL SELECT CONFIGURATION REGISTER DESCRIPTION

NAME	REG INDEX	DEFINITION	STATE
DMA Channel Select Default = 0x04 on Vcc POR or Reset_Drv	0x74 (R/W)	Bits[2:0] select the DMA Channel. 0x00=DMA0 0x01=DMA1 0x02=DMA2 0x03=DMA3 0x04-0x07= No DMA active	C

Note: A DMA channel is activated by setting the DMA Channel Select register to [0x00-0x03] AND :
 for the FDC logical device by setting DMAEN, bit D3 of the Digital Output Register.
 for the PP logical device in ECP mode by setting dmaEn, bit D3 of the ecr.
 for the UART 2 logical device, by setting the DMA Enable bit. Refer to the IRCC specification.
 Note:DMAREQ pins must tri-state if not used/selected by any Logical Device. Refer to Note A.

Note A. Logical Device IRQ and DMA Operation

- 1) IRQ and DMA Enable and Disable: Any time the IRQ or DACK for a logical block is disabled by a register bit in that logical block, the IRQ and/or DACK must be disabled. This is in addition to the IRQ and DACK disabled by the Configuration Registers (active bit or address not valid).
- 2) FDC: For the following cases, the IRQ and DACK used by the FDC are disabled (high impedance). Will not respond to the DREQ.
 - a) Digital Output Register (Base+2) bit D3 (DMAEN) set to "0".
 - b) The FDC is in power down (disabled).
- 3) Serial Port 1 and 2: Modem Control Register (MCR) Bit D2 (OUT2) - When OUT2 is a logic "0", the serial port interrupt is forced to a high impedance state - disabled.
- 4) Parallel Port: SPP and EPP modes: Control Port (Base+2) bit D4 (IRQE) set to "0", IRQ is disabled (high impedance).

a) ECP Mode:

i) (DMA) dmaEn from ecr register. See table.

ii) IRQ - See table.

MODE (FROM ECR REGISTER)		IRQ PIN CONTROLLED BY	PDREQ PIN CONTROLLED BY
000	PRINTER	IRQE	dmaEn
001	SPP	IRQE	dmaEn
010	FIFO	(on)	dmaEn
011	ECP	(on)	dmaEn
100	EPP	IRQE	dmaEn
101	RES	IRQE	dmaEn
110	TEST	(on)	dmaEn
111	CONFIG	IRQE	dmaEn

5) Real Time Clock and Keyboard Controller: Refer to the RTC and KBD section of this spec.

SMSC Defined Logical Device Configuration Registers

The SMSC Specific Logical Device Configuration Registers reset to their default values only on hard resets generated by Vcc POR or VTR POR or VBAT POR (as shown) or the RESET_DRV signal.

These registers are not affected by soft resets.

TABLE 76 - FLOPPY DISK CONTROLLER, LOGICAL DEVICE 0 [LOGICAL DEVICE NUMBER = 0X00]

NAME	REG INDEX	DEFINITION	STATE
FDD Mode Register Default = 0x0E on Vcc POR or Reset_Drv	0xF0 R/W	Bit[0] Floppy Mode = 0 Normal Floppy Mode (default) = 1 Enhanced Floppy Mode 2 (OS2) Bit[1] FDC DMA Mode = 0 Burst Mode is enabled = 1 Non-Burst Mode (default) Bit[3:2] Interface Mode = 11 AT Mode (default) = 10 (Reserved) = 01 PS/2 = 00 Model 30 Bit[4] Swap Drives 0,1 Mode = 0 No swap (default) = 1 Drive and Motor sel 0 and 1 are swapped. Bits[5] Reserved, set to zero. Bit [6] Output Type Control: 0= FDC outputs are OD24 open drain (default) 1= FDC outputs are O24 push-pull. Bit [7] FDC output Control: 0= FDC outputs active (default) 1= FDC outputs tristated Note: these bits do not affect the parallel port FDC pins.	C
FDD Option Register Default = 0x00 on Vcc POR or Reset_Drv	0xF1 R/W	Bits[1:0] Reserved, set to zero Bits[3:2] Density Select = 00 Normal (default) = 01 Normal (reserved for users) = 10 1 (forced to logic "1") = 11 0 (forced to logic "0") Bit[5:4] Reserved, set to zero Bits[7:6] Boot Floppy = 00 FDD 0 (default) = 01 FDD 1 = 10 Reserved (neither drive A or B is a boot drive). = 11 Reserved (neither drive A or B is a boot drive).	C
FDD Type Register Default = 0xFF on Vcc POR or Reset_Drv	0xF2 R/W	Bits[1:0] Floppy Drive A Type Bits[3:2] Floppy Drive B Type Bits[5:4] Reserved (could be used to store Floppy Drive C type) Bits[7:6] Reserved (could be used to store Floppy Drive D type) Note: The FDC37B78x supports two floppy drives	C
	0xF3 R	Reserved, Read as 0 (read only)	C

NAME	REG INDEX	DEFINITION	STATE
FDD0 Default = 0x00 on Vcc POR or Reset_Drv	0xF4 R/W	Bits[1:0] Drive Type Select: DT1, DT0 Bits[2] Read as 0 (read only) Bits[4:3] Data Rate Table Select: DRT1, DRT0 Bits[5] Read as 0 (read only) Bits[6] Precompensation Disable PTS =0 Use Precompensation =1 No Precompensation Bits[7] Read as 0 (read only)	C
FDD1	0xF5 R/W	Refer to definition and default for 0xF4	C

Parallel Port, Logical Device 3

TABLE 77 - PARALLEL PORT, LOGICAL DEVICE 3 [LOGICAL DEVICE NUMBER = 0X03]

NAME	REG INDEX	DEFINITION	STATE
PP Mode Register Default = 0x3C on Vcc POR or Reset_Drv	0xF0 R/W	<p>Bits[2:0] Parallel Port Mode = 100 Printer Mode (default) = 000 Standard and Bi-directional (SPP) Mode = 001 EPP-1.9 and SPP Mode = 101 EPP-1.7 and SPP Mode = 010 ECP Mode = 011 ECP and EPP-1.9 Mode = 111 ECP and EPP-1.7 Mode</p> <p>Bit[6:3] ECP FIFO Threshold 0111b (default)</p> <p>Bit[7] PP Interrupt Type Not valid when the parallel port is in the Printer Mode (100) or the Standard & Bi-directional Mode (000). = 1 Pulsed Low, released to high-Z. = 0 IRQ follows nACK when parallel port in EPP Mode or [Printer,SPP, EPP] under ECP.</p> <p>IRQ level type when the parallel port is in ECP, TEST, or Centronics FIFO Mode.</p>	C
PP Mode Register 2 Default = 0x00 on Vcc POR or Reset_Drv	0xF1 R/W	<p>Bits[1:0] PPFDC - muxed PP/FDC control = 00 Normal Parallel Port Mode = 01 PPFDC1: Drive 0 is on the FDC pins Drive 1 is on the Parallel port pins Drive 2 is on the FDC pins Drive 3 is on the FDC pins = 10 PPFDC2: Drive 0 is on the Parallel port pins Drive 1 is on the Parallel port pins Drive 2 is on the FDC pins Drive 3 is on the FDC pins</p> <p>Bits[7:2] Reserved. Set to zero.</p>	

Serial Port 1, Logical Device 4

TABLE 78 - SERIAL PORT 1, LOGICAL DEVICE 4 [LOGICAL DEVICE NUMBER = 0X04]

NAME	REG INDEX	DEFINITION	STATE
Serial Port 1 Mode Register Default = 0x00 on Vcc POR or Reset_Drv	0xF0 R/W	Bit[0] MIDI Mode = 0 MIDI support disabled (default) = 1 MIDI support enabled Bit[1] High Speed = 0 High Speed Disabled(default) = 1 High Speed Enabled Bit[6:2] Reserved, set to zero Bit[7]: Share IRQ =0 UARTS use different IRQs =1 UARTS share a common IRQ See Note 1 below.	C

Note 1: To properly share and IRQ,

1. Configure UART1 (or UART2) to use the desired IRQ pin.
2. Configure UART2 (or UART1) to use No IRQ selected.
3. Set the share IRQ bit.

Note: If both UARTs are configured to use different IRQ pins and the share IRQ bit is set, then both of the UART IRQ pins will assert when either UART generates an interrupt.

TABLE 79 - UART INTERRUPT OPERATION

UART1		UART2			IRQ PINS	
UART1 OUT2 bit	UART1 IRQ State	UART2 OUT2 bit	UART2 IRQ State	Share IRQ Bit	UART1 Pin State	UART2 Pin State
This part of the table is based on the assumption that both UARTS have selected different IRQ pins						
0	Z	0	Z	0	Z	Z
1	asserted	0	Z	0	1	Z
1	de-asserted	0	Z	0	0	Z
0	Z	1	asserted	0	Z	1
0	Z	1	de-asserted	0	Z	0
1	asserted	1	asserted	0	1	1
1	asserted	1	de-asserted	0	1	0
1	de-asserted	1	asserted	0	0	1
1	de-asserted	1	de-asserted	0	0	0
0	Z	0	Z	1	Z	Z
1	asserted	0	Z	1	1	1
1	de-asserted	0	Z	1	0	0
0	Z	1	asserted	1	1	1
0	Z	1	de-asserted	1	0	0
1	asserted	1	asserted	1	1	1
1	asserted	1	de-asserted	1	1	1
1	de-asserted	1	asserted	1	1	1
1	de-asserted	1	de-asserted	1	0	0
It is the responsibility of the software to ensure that two IRQ's are not set to the same IRQ number. However, if they are set to the same number then no damage to the chip will result.						

Serial Port 2, Logical Device 5

TABLE 80 - SERIAL PORT 2, LOGICAL DEVICE 5 [LOGICAL DEVICE NUMBER = 0X05]

NAME	REG INDEX	DEFINITION	STATE
Serial Port 2 Mode Register Default = 0x00 on Vcc POR or Reset_Drv	0xF0 R/W	Bit[0] MIDI Mode = 0MIDI support disabled (default) = 1MIDI support enabled Bit[1] High Speed = 0High Speed disabled(default) = 1High Speed enabled Bit[7:2] Reserved, set to zero	C
IR Option Register Default = 0x02 on Vcc POR or Reset_Drv	0xF1 R/W (EN 1)	Bit[0] Receive Polarity = 0 Active High (Default) = 1 Active Low Bit[1] Transmit Polarity = 0 Active High = 1 Active Low (Default) Bit[2] Duplex Select = 0 Full Duplex (Default) = 1 Half Duplex Bits[5:3] IR Mode = 000 Standard (Default) = 001 IrDA = 010 ASK-IR = 011 Reserved = 1xx Reserved Bit[6] IR Location Mux = 0 Use Serial port TXD2 and RXD2 (Default) = 1Use alternate IRRX2 (pin 81) and IRTX2 (pin 82) Bit[7] Reserved, write 0	C
IR Half Duplex Timeout Default = 0x03 on Vcc POR or Reset_Drv	0xF2	Bits [7:0] These bits set the half duplex time-out for the IR port. This value is 0 to 10msec in 100usec increments. 0= blank during transmit/receive 1= blank during transmit/receive + 100usec ...	

RTC, Logical Device 6

TABLE 81 - RTC, LOGICAL DEVICE 6 [LOGICAL DEVICE NUMBER = 0X06]

NAME	REG INDEX	DEFINITION	STATE
RTC Mode Register Default = 0x00 on Vcc POR or Reset_Drv	0xF0 R/W	Bit[0] = 1 : Lock CMOS RAM 00-1Fh in Bank 1 Bit[1] = 1 : Lock CMOS RAM 20-3Fh in Bank 1 Bit[2] = 1 : Lock CMOS RAM 40-5Fh in Bank 1 Bit[3] = 1 : Lock CMOS RAM 60-7Fh in Bank 1 Bits[5:4] RTC Bank Selection =00 Bank 1 at Secondary Base Address, Bank 0 Off (Default) =01 Bank 0 at 70h and Bank 1 at Secondary Base Address ^(Note 1) =10 No Bank Selected =11 Bank 0 at 70h, Bank 1 Off Bit[7:6] Reserved Note: Once set, bits[3:0] can not be cleared by a write; bits[3:0] are cleared only on Vcc Power On Reset or upon a Hard Reset.	C

Note 1: The secondary base address must be set to a value other than 70h prior to selecting this option.

KYBD, Logical Device 7

TABLE 82 - KYBD, LOGICAL DEVICE 7 [LOGICAL DEVICE NUMBER = 0X07]

NAME	REG INDEX	DEFINITION	STATE
KRST_GA20 Default = 0x00 on Vcc POR or Reset_Drv	0xF0 R/W	KRESET and GateA20 Select Bit[7] Polarity Select for P12 = 0 P12 active low (default) = 1 P12 active high Bits[6:3] Reserved Bit[2] Port 92 Select = 0 Port 92 Disabled = 1 Port 92 Enabled Bit[1] GATEA20 Select = 0 Software Control = 1 Hardware Speed-up Bit[0] KRESET Select = 0 Software Control = 1 Hardware Speed-up	
	0xF1 - 0xFF	Reserved - read as '0'	

Auxiliary I/O, Logical Device 8

TABLE 83 - AUXILIARY I/O, LOGICAL DEVICE 8 [LOGICAL DEVICE NUMBER = 0X08]

NAME	REG INDEX	DEFINITION	STATE
Soft Power Enable Register 1 Default = 0x00 on Vbat POR	0xB0 R/W	The following bits are the enables for the wake-up function of the nPowerOn bit. When enabled, these bits allow their corresponding function to turn on power to the system. 1 = ENABLED 0 = DISABLED Bit[0] SP_RI1: UART 1 Ring Indicator Pin Bit[1] SP_RI2: UART 2 Ring Indicator Pin Bit[2] SP_KCLK: Keyboard Clock pin Bit[3] SP_MCLK: Mouse Clock pin Bit[4] SP_GPINT1: Group Interrupt 1 Bit[5] SP_GPINT2: Group Interrupt 2 Bit[6] SP_IRRX2: IRRX2 input pin Bit[7] SP_RTC ALARM: RTC Alarm	C
Soft Power Enable Register 2 Default = 0x80 on Vbat POR	0xB1 R/W	The following bits are the enables for the wake-up function of the nPowerOn bit. When enabled, these bits allow their corresponding function to turn on power to the system. 1 = ENABLED 0 = DISABLED Bit[0] SP_RXD1: UART 1 Receive Data Pin Bit[1] SP_RXD2: UART 2 Receive Data Pin Bit[2] Reserved Bit[3] RING Enable bit "RING_EN" 0=Disable. 1=Enable ring indicator on nRING pin as wakeup function to activate nPowerOn. Bit[4] Reserved Bit[5] CIR Enable bit "CIR_EN" 0=Disable. 1=Enable CIR wakeup event to activate nPowerOn Bit[6] Reserved Bit[7] OFF_EN: After power up, this bit defaults to 1, i.e., enabled. This bit allows the software to enable or disable the button control of power off.	C

NAME	REG INDEX	DEFINITION	STATE
<p>Soft Power Status Register 1</p> <p>Default = 0x00 on Vbat POR</p>	<p>0xB2 R/W</p>	<p>The following bits are the status for the wake-up function of the nPowerOn bit. These indicate which of the enabled wakeup functions caused the power up.</p> <p>1 = Occured 0 = Did not occur since last cleared</p> <p>The following signals are latched to detect and hold the soft power event (Type 1) (Note 1)</p> <p>Bit[0] RI1: UART 1 Ring Indicator; high to low transition on the pin, cleared by a read of this register</p> <p>Bit[1] RI2: UART 2 Ring Indicator; high to low transition on the pin, cleared by a read of this register</p> <p>Bit[2] KCLK: Keyboard clock; high to low transition on the pin, cleared by a read of this register</p> <p>Bit[3] MCLK: Mouse clock; high to low transition on the pin, cleared by a read of this register</p> <p>Bit[6] IRRX2: IRRX2 input; high to low transition on the pin, cleared by a read of this register</p> <p>Bit[7] RTC ALARM: RTC Alarm; status of the RTC Alarm internal signal. Cleared by a read of the status register.</p> <p>The following signals are not latched to detect and hold the soft power event (Type 2) (Note 1)</p> <p>Bit[4] GPINT1: Group Interrupt 1; status of the GPINT1 internal signal. Cleared at the source</p> <p>Bit[5] GPINT2: Group Interrupt 2; status of the GPINT2 internal signal. Cleared at the source</p>	<p>C</p>

NAME	REG INDEX	DEFINITION	STATE
<p>Soft Power Status Register 2</p> <p>Default = 0x00 on Vbat POR</p>	<p>0xB3 R/W</p>	<p>The following bits are the status for the wake-up function of the nPowerOn bit. These indicate which of the enabled wakeup functions caused the power up.</p> <p>1 = Occured 0 = Did not occur since last cleared</p> <p>The following signals are latched to detect and hold the soft power event (Type 1) (Note 1)</p> <p>Bit[0] RXD1: UART 1 Receive Data; high to low transition on the pin, cleared by a read of this register Bit[1] RXD2: UART 2 Receive Data; high to low transition on the pin, cleared by a read of this register Bit[3] RING Status bit "RING_STS"; Latched, cleared on read. 0= nRING input did not occur. 1= Ring indicator input occurred on the nRING pin and, if enabled, caused the wakeup (activated nPowerOn) Bit[4] Reserved</p> <p>Bit[5] CIR Status bit "CIR_STS"; latched, cleared on read. 0= CIR wakeup event did not occur. 1= CIR wakeup event occurred and, if enabled, caused the wakeup (activated nPowerOn).</p> <p>The following signal is latched to detect and hold the soft power event (Type 3) (Note 1) but the output of the latch does not feed into the power down circuitry:</p> <p>Bit[2] Button: Button pressed, Cleared by a read of this register</p> <p>Bits[7:6] Reserved</p>	<p>C</p>

NAME	REG INDEX	DEFINITION	STATE
Delay 2 Time Set Register Default = 0x00 on VTR POR	0xB8 R/W	This register is used to set Delay 2 (for Soft Power Management) to a value from 500 msec to 32 sec. The default value is 500msec. Engineering Note: this delay is started if OFF_EN is enabled and OFF_DLY was set and a Button Input comes in. Bits[5:0] The value of these bits correspond to the delay time as follows: 000000= 500msec min to 510msec max 000001= 1sec min to 1.01sec max 000010= 1.5sec min to 1.51sec max 000011= 2sec min to 2.01sec max ... 111111 = 32sec min to 32.01sec max Bits[7:6] Reserved	C

NAME	REG INDEX	DEFINITION	STATE
<p>IRQ Mux Control Register</p> <p>Default = 0x00 on Vbat POR</p>	<p>0XC0 R/W</p>	<p>This register is used to configure the IRQs, including PME, SCI and SMI.</p> <p>Bit[0] Serial/Parallel IRQs 0=Serial IRQs are used 1=Parallel IRQS are used Note 1: This bit does not control the RTC IRQ, SCI or SMI interrupts. See bits 1,2,7 of this register. Note 2: If set, the BIOS buffer is disabled. Also, the SER_IRQ and PCI_CLK pins are disabled, and these pins function as IRQ15 and IRQ14, respectively. Note 3: Select IRQ9 below. Select RTC IRQ and SCI below. Select nSMI through the SMI register.</p> <p>Bit[1] RTC IRQ Select. 0=RTC IRQ on serial IRQ frame 1=RTC IRQ on IRQx pin</p> <p>Bit[2] SCI Select 0=SCI is on serial IRQ frame 1=SCI is on IRQx pin Note: Serial IRQs are not available under V_{TR} power.</p> <p>Bit[3] SCI Polarity Select (EN1) 0=SCI active low 1=SCI active high</p> <p>Bit[4] SCI Buffer Type (EN1) 0=Push-pull 1=Open drain</p> <p>Bit[6:5] SCI/PME/IRQ9 Pin select 00=Pin 21 is used for nPME signal. 01=Pin 21 is used for SCI. 10=Pin 21 is used for IRQ9. 11=Reserved Engineering Note: If bit 5 is set, this overrides the setting of the IRQ for SCI in Config Register 0x70 of Logical Device A. See the logic in the SCI section. Enginreering Note: This bit selects the buffer type of the pin as follows: if nPME is selected, it is active low OD; if SCI is selected, the buffer type and polarity are selected through bits 3 and 4 of this register; if IRQ9 is selected, it is an active high push-pull output.</p> <p>Bit[7] SMI Select 0=SMI is on serial IRQ frame (IRQ2) 1=SMI is on nSMI pin Engineering Note: the polarity and buffer type of the SMI pin is selected through the GPIO registers (default is active low open drain).</p>	

NAME	REG INDEX	DEFINITION	STATE
Forced Disk Change Default = 0x03 on VTR POR	0xC1 R/W	Force Change 1 and Force Change 0 can be written to 1 are not clearable by software. Force Change 1 is cleared on (nSTEP AND nDS1) Force Change 0 is cleared on (nSTEP AND nDS0). DSK CHG (Floppy DIR Register, Bit 7) = (nDS0 AND Force Change 0) OR (nDS1 AND Force Change 1) OR nDSKCHG. Setting either of the Force Disk Change bits active (1) forces the FDD nDSKCHG input active when the appropriate drive has been selected. Bit[0] Force Change for FDC0 0=Inactive 1=Active Bit[1] Force Change for FDC1 0=Inactive 1=Active Bit[2:7] Reserved, Reads 0	
Floppy Data Rate Select Shadow	0xC2 R	Floppy Data Rate Select Shadow Register Bit[7] Soft Reset Bit[6] Power Down Bit[5] Reserved Bit[4] PRECOMP 2 Bit[3] PRECOMP 1 Bit[2] PRECOMP 0 Bit[1] Data Rate Select 1 Bit[0] Data Rate Select 0	
UART1 FIFO Control Shadow	0xC3 R	UART1 FIFO Control Shadow Register Bit[7] RCVR Trigger MSB Bit[6] RCVR Trigger LSB Bit[5] Reserved Bit[4] Reserved Bit[3] DMA Mode Select Bit[2] XMIT FIFO Reset Bit[1] RCVR FIFO Reset Bit[0] FIFO Enable	
UART2 FIFO Control Shadow	0xC4 R	UART2 FIFO Control Shadow Register Bit[7] RCVR Trigger MSB Bit[6] RCVR Trigger LSB Bit[5] Reserved Bit[4] Reserved Bit[3] DMA Mode Select Bit[2] XMIT FIFO Reset Bit[1] RCVR FIFO Reset Bit[0] FIFO Enable	

NAME	REG INDEX	DEFINITION	STATE
Forced Write Protect Default = 0x00 on VTR POR	0xC5 R/W	Force Write Protect function forces the FDD nWRTPRT input active if the FORCE WRTPRT bit is active. The Force Write Protect function applies to the nWRTPRT pin in the FDD Interface as well as the nWRTPRT pin in the Parallel Port FDC. Bit[0] Force Write Protect bit FDD0 0 = Inactive (Default) 1 = Active "forces the FDD nWRTPRT input active when the drive has been selected" Note 2 Bit[1:7] Reserved, reads 0.	
Ring Filter Select Register Default = 0x00 on Vbat POR Note 3	0xC6 R/W	This register is used to select the operation of the ring indicator on the nRI1, nRI2 and nRING pins. Bit[0]: 1=Enable detection of pulse train of frequency 15Hz or higher for 200msec and generate an active low pulse for its duration to use as the ring indicator function on nRING pin. The leading high-to-low edge is the trigger for the ring indication. 0=Ring indicate function is high-to-low transition on the nRING pin. Bit[1]: 1=Enable detection of pulse train of frequency 15Hz or higher and generate an active low pulse for its duration to use for 200msec as the ring indicator function on nRI1 pin. The leading high-to-low edge is the trigger for the ring indication. 0=Ring indicate function is high-to-low transition on the nRI1 pin. Bit[2]: 1=Enable detection of pulse train of frequency 15Hz or higher and generate an active low pulse for its duration to use for 200msec as the ring indicator function on nRI2 pin. The leading high-to-low edge is the trigger for the ring indication. 0=Ring indicate function is high-to-low transition on the nRI2 pin. Bits[7:3] Reserved	C

Note 1: There are three types of events Type 1, Type 2 and Type 3.

Type 1: This is an event that comes from a pin or internal signal to the chip. This needs to be edge detected and latched until cleared by a read of the register. The output of the latch is used to turn on the power supply through the "or" logic.

Type 2: This is an event that comes from a pin or internal signal to the chip. This does not need to be edge detected and latched. Cleared at the source.

Type 3: This is an event that comes from a pin or internal signal to the chip. This needs to be edge detected and latched until cleared by a read of the register. The output of the latch is not used to turn on the power supply through the "or" logic.

Note 2: $nWRTprt$ (to the FDC Core) = ($nDS0$ AND FORCE $WRTprt$ 0) OR $nWRTprt$ (from the FDD Interface). The Force Write Protect 0 bit also applies to the Parallel Port FDC. This bit applies to both drives.

Note 3: The ring wakeup filter will produce an active low pulse for the period of time that $nRING$, $nR11$ and/or $nR12$, $nR11$ and/or $nR12$ is toggling.

TABLE 84 - AUXILLIARY I/O, LOGICAL DEVICE 8 [LOGICAL DEVICE NUMBER = 0X08]

NAME	REG INDEX	DEFINITION	STATE
GP10 Default = 0x01 on Vbat POR	0xE0	General Purpose I/O bit 1.0 Bit[0] In/Out : =1 Input, =0 Output Bit[1] Polarity : =1 Invert, =0 No Invert Bit[2] Group Interrupt Enable =1 Enable Combined IRQ 1 =0 Disable Combined IRQ 1 Bit[3] Function Select =1 nSMI =0 GPI/O Bits[6:4] Reserved Bit[7] Output Type Select 1=Open Drain 0=Push Pull	C
GP11 Default = 0x01 on Vbat POR	0xE1	General Purpose I/O bit 1.1 Bit[0] In/Out : =1 Input, =0 Output Bit[1] Polarity : =1 Invert, =0 No Invert Bit[2] Group Interrupt Enable =1 Enable Combined IRQ 1 =0 Disable Combined IRQ 1 Bit[4:3] Function Select =00 GPI/O =01 nRING =10 Either Edge Triggered Interrupt 1 =11 Reserved Bits[6:5] Reserved Bit[7] Output Type Select 1=Open Drain 0=Push Pull Bit	C
GP12 Default = 0x01 on Vbat POR	0xE2	General Purpose I/O bit 1.2 Bit[0] In/Out : =1 Input, =0 Output Bit[1] Polarity : =1 Invert, =0 No Invert Bit[2] Group Interrupt Enable =1 Enable Combined IRQ 1 =0 Disable Combined IRQ 1 Bit[4:3] Function Select =00 GPI/O =01 WDT =10 P17 =11 Either Edge Triggered Interupt 2 Bits[6:5] Reserved Bit[7] Output Type Select 1=Open Drain 0=Push Pull Bit	C
GP13	0xE3	General Purpose I/O bit 1.3 Bit[0] In/Out : =1 Input, =0 Output	C

NAME	REG INDEX	DEFINITION	STATE
Default = 0x01 on Vbat POR		Bit[1] Polarity : =1 Invert, =0 No Invert Bit[2] Group Interrupt Enable =1 Enable Combined IRQ 1 =0 Disable Combined IRQ 1 Bit[3] Function Select =1 LED =0 GPI/O Bits[6:4] Reserved Bit[7] Output Type Select 1=Open Drain 0=Push Pull Bit	
GP14 Default = 0x01 on Vbat POR	0xE4	General Purpose I/O bit 1.4 Bit[0] In/Out : =1 Input, =0 Output Bit[1] Polarity : =1 Invert, =0 No Invert Bit[2] Group Interrupt Enable =1 Enable Combined IRQ 1 =0 Disable Combined IRQ 1 Bit[3] Function Select =1 IRRX2 =0 GPI/O Bits[6:4] Reserved Bit[7] Output Type Select 1=Open Drain 0=Push Pull Bit	C
GP15 Default = 0x00 on Vbat POR	0xE5	General Purpose I/O bit 1.5 Bit[0] In/Out : =1 Input, =0 Output Bit[1] Polarity : =1 Invert, =0 No Invert Bit[2] Group Interrupt Enable =1 Enable Combined IRQ 1 =0 Disable Combined IRQ 1 Bit[3] Function Select =1 IRTX2 =0 GPI/O Bits[6:4] Reserved Bit[7] Output Type Select 1=Open Drain 0=Push Pull	C
GP16 Default = 0x01 on Vbat POR	0xE6	General Purpose I/O bit 1.6 Bit[0] In/Out : =1 Input, =0 Output Bit[1] Polarity : =1 Invert, =0 No Invert Bit[2] Group Interrupt Enable =1 Enable Combined IRQ 1 =0 Disable Combined IRQ 1 Bit[3] Function Select =1 nMTR1 =0 GPI/O Bits[6:4] Reserved	C

NAME	REG INDEX	DEFINITION	STATE
GP17 Default = 0x01 on Vbat POR	0xE7	Bit[7] Output Type Select 1=Open Drain 0=Push Pull Bit General Purpose I/O bit 1.7 Bit[0] In/Out : =1 Input, =0 Output Bit[1] Polarity : =1 Invert, =0 No Invert Bit[2] Group Interrupt Enable =1 Enable Combined IRQ 1 =0 Disable Combined IRQ 1 Bit[3] Function Select =1 nDS1 =0 GPI/O Bits[6:4] Reserved Bit[7] Output Type Select 1=Open Drain 0=Push Pull	C
GP50 Default = 0x01 on Vbat POR	0xC8	General Purpose I/O bit 5.0 Bit[0] In/Out : =1 Input, =0 Output Bit[1] Polarity : =1 Invert, =0 No Invert Bit[2] Reserved Bit[4:3] Function Select =00 PCI Clock =01 IRQ14 =10 GPI/O =11 Reserved Bit[5] Group Interrupt Enable =1 Enable Combined IRQ 2 =0 Disable Combined IRQ 2 Bit[6] Reserved Bit[7] Output Type Select 1=Open Drain 0=Push Pull	
GP52 Default =0x09 on Vbat POR	0xCA	General Purpose I/O bit 5.2 Bit[0] In/Out : =1 Input, =0 Output Bit[1] Polarity : =1 Invert, =0 No Invert Bit[2] Reserved Bit[4:3] Function Select =00 DRVDEN1 =01 GPIO =10 IRQ8 =11 nSMI Bit[5] Group Interrupt Enable =1 Enable Combined IRQ 2 =0 Disable Combined IRQ 2 Bit[6] Reserved Bit[7] Output Type Select 1=Open Drain	

NAME	REG INDEX	DEFINITION	STATE
GP53 Default =0x01 on Vbat POR	0xCB	0=Push Pull General Purpose I/O bit 5.3 Bit[0] In/Out : =1 Input, =0 Output Bit[1] Polarity : =1 Invert, =0 No Invert Bit[2] Reserved Bit[4:3] Function Select =00 nROMCS =01 IRQ11 =10 GPI/O =11 Either Edge Triggered Interrupt 3 Bit[5] Group Interrupt Enable =1 Enable Combined IRQ 2 =0 Disable Combined IRQ 2 Bit[6] Reserved Bit[7] Output Type Select 1=Open Drain 0=Push Pull	
GP54 Default = 0x01 on Vbat POR	0xCC	General Purpose I/O bit 5.4 Bit[0] In/Out : =1 Input, =0 Output Bit[1] Polarity : =1 Invert, =0 No Invert Bit[2] Reserved Bit[4:3] Function Select =00 nROMOE =01 IRQ12 =10 GPI/O =11 Either Edge Triggered Interrupt 4 Bit[5] Group Interrupt Enable =1 Enable Combined IRQ 2 =0 Disable Combined IRQ 2 Bit[6] Reserved Bit[7] Output Type Select 1=Open Drain 0=Push Pull	
GP60 Default = 0x01 on Vbat POR	0xD0	General Purpose I/O bit 6.0 Bit[0] In/Out : =1 Input, =0 Output Bit[1] Polarity : =1 Invert, =0 No Invert Bit[2] Reserved Bit[4:3] Function Select =00 RD0 =01 IRQ1 =10 GPI/O =11 nSMI Bit[5] Group Interrupt Enable =1 Enable Combined IRQ 2 =0 Disable Combined IRQ 2 Bit[6] Reserved Bit[7] Output Type Select	

NAME	REG INDEX	DEFINITION	STATE
		1=Open Drain 0=Push Pull	
GP61 Default = 0x01 on Vbat POR	0xD1	General Purpose I/O bit 6.1 Bit[0] In/Out : =1 Input, =0 Output Bit[1] Polarity : =1 Invert, =0 No Invert Bit[2] Reserved Bit[4:3] Function Select =00 RD1 =01 IRQ3 =10 GPI/O =11 LED Bit[5] Group Interrupt Enable =1 Enable Combined IRQ 2 =0 Disable Combined IRQ 2 Bit[6] Reserved Bit[7] Output Type Select 1=Open Drain 0=Push Pull	
GP62 Default = 0x01 on Vbat POR	0xD2	General Purpose I/O bit 6.2 Bit[0] In/Out : =1 Input, =0 Output Bit[1] Polarity : =1 Invert, =0 No Invert Bit[2] Reserved Bit[4:3] Function Select =00 RD2 =01 IRQ4 =10 GPI/O =11 nRING Bit[5] Group Interrupt Enable =1 Enable Combined IRQ 2 =0 Disable Combined IRQ 2 Bit[6] Reserved Bit[7] Output Type Select 1=Open Drain 0=Push Pull	
GP63 Default = 0x01 on Vbat POR	0xD3	General Purpose I/O bit 6.3 Bit[0] In/Out : =1 Input, =0 Output Bit[1] Polarity : =1 Invert, =0 No Invert Bit[2] Reserved Bit[4:3] Function Select =00 RD3 =01 IRQ5 =10 GPI/O =11 WDT Bit[5] Group Interrupt Enable =1 Enable Combined IRQ 2 =0 Disable Combined IRQ 2 Bit[6] Reserved	

NAME	REG INDEX	DEFINITION	STATE
		Bit[7] Output Type Select 1=Open Drain 0=Push Pull	
GP64 Default = 0x01 on Vbat POR	0xD4	General Purpose I/O bit 6.4 Bit[0] In/Out : =1 Input, =0 Output Bit[1] Polarity : =1 Invert, =0 No Invert Bit[2] Reserved Bit[4:3] Function Select =00 RD4 =01 IRQ6 =10 GPI/O =11 P17 Bit[5] Group Interrupt Enable =1 Enable Combined IRQ 2 =0 Disable Combined IRQ 2 Bit[6] Reserved Bit[7] Output Type Select 1=Open Drain 0=Push Pull	
GP65 Default = 0x01 on Vbat POR	0xD5	General Purpose I/O bit 6.5 Bit[0] In/Out : =1 Input, =0 Output Bit[1] Polarity : =1 Invert, =0 No Invert Bit[2] Reserved Bit[4:3] Function Select =00 RD5 =01 IRQ7 =10 GPI/O =11 Reserved Bit[5] Group Interrupt Enable =1 Enable Combined IRQ 2 =0 Disable Combined IRQ 2 Bit[6] Reserved Bit[7] Output Type Select 1=Open Drain 0=Push Pull	
GP66 Default = 0x01 on Vbat POR	0xD6	General Purpose I/O bit 6.6 Bit[0] In/Out : =1 Input, =0 Output Bit[1] Polarity : =1 Invert, =0 No Invert Bit[2] Reserved Bit[4:3] Function Select =00 RD6 =01 IRQ8 =10 GPI/O =11 Reserved Bit[5] Group Interrupt Enable =1 Enable Combined IRQ 2 =0 Disable Combined IRQ 2	

NAME	REG INDEX	DEFINITION	STATE
		Bit[6] Reserved Bit[7] Output Type Select 1=Open Drain 0=Push Pull	
GP67 Default = 0x01 on Vbat POR	0xD7	General Purpose I/O bit 6.7 Bit[0] In/Out : =1 Input, =0 Output Bit[1] Polarity : =1 Invert, =0 No Invert Bit[2] Reserved Bit[4:3] Function Select =00 RD7 =01 IRQ10 =10 GPI/O =11 Reserved Bit[5] Group Interrupt Enable =1 Enable Combined IRQ 2 =0 Disable Combined IRQ 2 Bit[6] Reserved Bit[7] Output Type Select 1=Open Drain 0=Push Pull	
GP_INT2 Default = 0x00 on Vbat POR	0xEF	General Purpose I/O Combined Interrupt 2 Bits[2:0] Reserved, = 000 Bit[3] GP IRQ Filter Select 0 = Debounce Filter Bypassed 1 = Debounce Filter Enabled Bits[7:4] Combined IRQ mapping 1111 = IRQ15 0011 = IRQ3 0010 = Invalid 0001 = IRQ1 0000 = Disable	
GP_INT1 Default = 0x00 on Vbat POR	0xF0	General Purpose I/O Combined Interrupt 1 Bits[2:0] Reserved, = 000 Bit[3] GP IRQ Filter Select 0 = Debounce Filter Bypassed 1 = Debounce Filter Enabled Bits[7:4] Combined IRQ mapping 1111 = IRQ15 0011 = IRQ3 0010 = Invalid 0001 = IRQ1 0000 = Disable	C
WDT_UNITS	0xF1	Watch Dog Timer Units Bits[6:0] Reserved, = 00000 Bit[7] WDT Time-out Value Units Select	C

NAME	REG INDEX	DEFINITION	STATE
Default = 0x00 on Vcc POR or Reset_Drv		= 0 Minutes (default) = 1 Seconds Note: if the logical device's activate bit is not set then bits 0 and 1 have no effect.	
WDT_VAL Default = 0x00 on Vcc POR or Reset_Drv	0xF2	Watch-dog Timer Time-out Value Binary coded, units = minutes(default) or seconds, selectable via Bit[7] of Reg 0xF1, LD 8. 0x00 Time out disabled 0x01 Time-out = 1 minute/second 0xFF Time-out = 255 minutes/seconds	C
WDT_CFG Default = 0x00 on Vcc POR or Reset_Drv	0xF3	Watch-dog timer Configuration Bit[0] Joy-stick Enable =1WDT is reset upon an I/O read or write of the Game Port =0WDT is not affected by I/O reads or writes to the Game Port. Bit[1] Keyboard Enable =1WDT is reset upon a Keyboard interrupt. =0WDT is not affected by Keyboard interrupts. Bit[2] Mouse Enable =1WDT is reset upon a Mouse interrupt =0WDT is not affected by Mouse interrupts. Bit[3] PWRLed Time-out enable =1Enables the Power LED to toggle at a 1Hz rate with 50 percent duty cycle while the Watch-dog Status bit is set. =0Disables the Power LED toggle during Watch-dog timeout status. Bits[7:4] WDT Interrupt Mapping 1111 = IRQ15 0011 = IRQ3 0010 = Invalid 0001 = IRQ1 0000 = Disable	C
WDT_CTRL Default = 0x00 Cleared by VTR POR	0xF4	Watch-dog timer Control Bit[0] Watch-dog Status Bit, R/W =1WD timeout occurred =0WD timer counting Bit[1] Power LED Toggle Enable, R/W =1Toggle Power LED at 1Hz rate with 50 percent duty cycle. (1/2 sec. on, 1/2 sec. off) =0Disable Power LED Toggle Bit[2] Force Timeout, W =1Forces WD timeout event; this bit is self-clearing Bit[3] P20 Force Timeout Enable, R/W	C

NAME	REG INDEX	DEFINITION	STATE
GP1 Default = 0x00 on Vbat POR	0xF6	<p>= 1Allows rising edge of P20, from the Keyboard Controller, to force the WD timeout event. A WD timeout event may still be forced by setting the Force Timeout Bit, bit 2.</p> <p>= 0P20 activity does not generate the WD timeout event.</p> <p>Note: The P20 signal will remain high for a minimum of 1us and can remain high indefinitely. Therefore, when P20 forced timeouts are enabled, a self-clearing edge-detect circuit is used to generate a signal which is ORed with the signal generated by the Force Timeout Bit.</p> <p>Bit[4] Reserved. Set to 0.</p> <p>Bit[5] Stop_Cnt: This is used to terminate Delay 2 (Note 1) without generating a power down. This is used if the software determines that the power down should be aborted. When read, this bit indicates the following: Stop_Cnt = 0; Counter running Stop_Cnt = 1; Counter Stopped. Note: The write is self clearing.</p> <p>Bit[6] Restart_Cnt: This is used to restart Delay 2 (Note 1) from the button input to the generation of the power down. When restarted, the count will start over and delay the power down for the time that Delay 2 is set for (Default=500msec). The software can continue to do this indefinitely without allowing a powerdown. This bit is self clearing. 1=Restart; Automatically cleared.</p> <p>Bit[7] SPOFF: This is used to force a software power down. This bit is self clearing.</p> <p>Note 1: This delay is programmable via the Delay 2 Time Set Register at Logical Device 8, 0xB8.</p>	
GP5 Default = 0x00 on Vbat POR	0xF9	<p>This register is used to read the value of the GPIO pins.</p> <p>Bit[0]: GP50</p> <p>Bit[1]: Reserved</p> <p>Bit[2]: GP52</p>	

NAME	REG INDEX	DEFINITION	STATE
GP6 Default = 0x00 on Vbat POR	0xFA	Bit[3]: GP53 Bit[4]: GP54 Bit[7:5]: Reserved This register is used to read the value of the GPIO pins. Bit[0]: GP60 Bit[1]: GP61 Bit[2]: GP62 Bit[3]: GP63 Bit[4]: GP64 Bit[5]: GP65 Bit[6]: GP66 Bit[7]: GP67	

Note: Registers GP1, WDT_CTRL, GP5-6, Soft Power Enable and Status Registers are also available at index 01-0F when not in configuration mode.

Note: GP10-17 can be enabled onto GPINT1; GP50-54 and GP60-67 can be enabled onto GPINT2.

ACPI, Logical Device A

TABLE 85 - ACPI, LOGICAL DEVICE A [LOGICAL DEVICE NUMBER = 0X0A]

NAME	REG INDEX	DEFINITION	STATE
<p>Sleep/Wake Configuration</p> <p>Default = 0x00 on Vbat POR</p>	<p>0xF0</p>	<p>This register is used to configure the functionality of the SLP_EN bit and its associated logic, and the WAK_STS bit and its associated logic. It also contains the CIR PLL Power bit.</p> <p>Bit[0] SLP_CTRL. SLP_EN Bit Function. 0=Default. Writing '1' to the SLP_EN bit causes the system to sequence into the sleeping state associated with the SLP_TYPx fields. 1=Writing '1' to the SLP_EN bit does not cause the system to sequence into the sleeping state associated with the SLP_TYPx fields; instead an SMI is generated. Note: the SLP_EN_SMI bit in the SMI Status Register 2 is set whenever '1' is written to the SLP_EN bit; it is enabled to generate an SMI through bit[0] of this register.</p> <p>Bit[1] WAK_CTRL. WAK_STS Bit Function 0=Default. The WAK_STS bit is set on the high-to-low transition of nPowerOn. 1=The WAK_STS bit is set upon any enabled wakeup event and the high-to-low transition of nPowerOn.</p> <p>Bits[2:6] Reserved</p> <p>Bit[7]: CIR PLL Power. 0=Default. The 32KHz clock PLL is unpowered 1=The 32KHz clock PLL is running and can replace the 14.318MHz clock source for the CIR wakeup event.</p>	<p>C</p>

OPERATIONAL DESCRIPTION

MAXIMUM GUARANTEED RATINGS

Operating Temperature Range.....	0°C to +70°C
Storage Temperature Range.....	-55° to +150°C
Lead Temperature Range (soldering, 10 seconds).....	+325°C
Positive Voltage on any pin, with respect to Ground.....	$V_{CC}+0.3V$
Negative Voltage on any pin, with respect to Ground.....	-0.3V
Maximum V_{CC}	+7V

*Stresses above those listed above could cause permanent damage to the device. This is a stress rating only and functional operation of the device at any other condition above those indicated in the operation sections of this specification is not implied.

Note: When powering this device from laboratory or system power supplies, it is important that the Absolute Maximum Ratings not be exceeded or device failure can result. Some power supplies exhibit voltage spikes on their outputs when the AC power is switched on or off. In addition, voltage transients on the AC power line may appear on the DC output. If this possibility exists, it is suggested that a clamp circuit be used.

DC ELECTRICAL CHARACTERISTICS

($T_A = 0^\circ\text{C} - 70^\circ\text{C}$, $V_{CC} = +5\text{ V} \pm 10\%$)

PARAMETER	SYMBOL	MIN	TYP	MAX	UNITS	COMMENTS
I Type Input Buffer						
Low Input Level	V_{ILI}			0.8	V	TTL Levels
High Input Level	V_{IHI}	2.0			V	
IS Type Input Buffer						
Low Input Level	V_{ILIS}			0.8	V	Schmitt Trigger
High Input Level	V_{IHIS}	2.2			V	Schmitt Trigger
Schmitt Trigger Hysteresis	V_{HYS}		250		mV	
ICLK Input Buffer						
Low Input Level	V_{ILCK}			0.4	V	
High Input Level	V_{IHCK}	2.2			V	
Input Leakage (All I and IS buffers)						
Low Input Leakage	I_{IL}	-10		+10	μA	$V_{IN} = 0$
High Input Leakage	I_{IH}	-10		+10	μA	$V_{IN} = V_{CC}$

PARAMETER	SYMBOL	MIN	TYP	MAX	UNITS	COMMENTS
IO4 Type Buffer						
Low Output Level	V_{OL}			0.4	V	$I_{OL} = 4 \text{ mA}$
High Output Level	V_{OH}	2.4			V	$I_{OH} = -2 \text{ mA}$
Output Leakage	I_{OL}	-10		+10	μA	$V_{IN} = 0 \text{ to } V_{CC}$ (Note 1)
O4 Type Buffer						
Low Output Level	V_{OL}			0.4	V	$I_{OL} = 4 \text{ mA}$
High Output Level	V_{OH}	2.4			V	$I_{OH} = -2 \text{ mA}$
Output Leakage	I_{OL}	-10		+10	μA	$V_{IN} = 0 \text{ to } V_{CC}$ (Note 1)
O8 Type Buffer						
Low Output Level	V_{OL}			0.4	V	$I_{OL} = 8 \text{ mA}$
High Output Level	V_{OH}	2.4			V	$I_{OH} = -4 \text{ mA}$
Output Leakage	I_{OL}	-10		+10	μA	$V_{IN} = 0 \text{ to } V_{CC}$ (Note 1)
IO12 Type Buffer						
Low Output Level	V_{OL}			0.4	V	$I_{OL} = 12 \text{ mA}$
High Output Level	V_{OH}	2.4			V	$I_{OH} = -6 \text{ mA}$
Output Leakage	I_{OL}	-10		+10	μA	$V_{IN} = 0 \text{ to } V_{CC}$ (Note 1)
O12 Type Buffer						
Low Output Level	V_{OL}			0.4	V	$I_{OL} = 12 \text{ mA}$
High Output Level	V_{OH}	2.4			V	$I_{OH} = -6 \text{ mA}$
Output Leakage	I_{OL}	-10		+10	μA	$V_{IN} = 0 \text{ to } V_{CC}$ (Note 1)
OD12 Type Buffer						
Low Output Level	V_{OL}			0.4	V	$I_{OL} = 12 \text{ mA}$
Output Leakage	I_{OL}	-10		+10	μA	$V_{IN} = 0 \text{ to } V_{CC}$ (Note 1)

PARAMETER	SYMBOL	MIN	TYP	MAX	UNITS	COMMENTS
IOP14 Type Buffer						
Low Output Level	V_{OL}			0.4	V	$I_{OL} = 14 \text{ mA}$
High Output Level	V_{OH}	2.4			V	$I_{OH} = -14 \text{ mA}$
Output Leakage	I_{OL}	-10		+10	μA	$V_{IN} = 0 \text{ to } V_{CC}$ (Note 1)
Backdrive Protected	I_{IL}			± 10	μA	$V_{CC}=0\text{V}; V_{CC}=V_{TR}=0\text{V}$ $V_{IN} = 6\text{V Max}$
OD14 Type Buffer						
Low Output Level	V_{OL}			0.4	V	$I_{OL} = 14 \text{ mA}$
Output Leakage	I_{OL}	-10		+10	μA	$V_{IN} = 0 \text{ to } V_{CC}$ (Note 1)
OP14 Type Buffer						
Low Output Level	V_{OL}			0.4	V	$I_{OL} = 14 \text{ mA}$
High Output Level	V_{OH}	2.4			V	$I_{OH} = -14 \text{ mA}$
Output Leakage	I_{OL}	-10		+10	μA	$V_{IN} = 0 \text{ to } V_{CC}$
Backdrive Protected	I_{IL}			± 10	μA	$V_{CC}=0\text{V}; V_{CC}=V_{TR}=0\text{V}$ $V_{IN} = 6\text{V Max}$
IOD16 Type Buffer						
Low Output Level	V_{OL}			0.4	V	$I_{OL} = 16 \text{ mA}$
Output Leakage	I_{OL}	-10			μA	$V_{IN} = 0 \text{ to } V_{CC}$
O24 Type Buffer						
Low Output Level	V_{OL}			0.4	V	$I_{OL} = 24 \text{ mA}$
High Output Level	V_{OH}	2.4			V	$I_{OH} = -12 \text{ mA}$
Output Leakage	I_{OL}	-10		+10	μA	$V_{IN} = 0 \text{ to } V_{CC}$ (Note 1)

PARAMETER	SYMBOL	MIN	TYP	MAX	UNITS	COMMENTS
IO24 Type Buffer						
Low Output Level	V_{OL}			0.4	V	$I_{OL} = 24 \text{ mA}$
High Output Level	V_{OH}	2.4			V	$I_{OH} = -12 \text{ mA}$
Output Leakage	I_{OL}	-10		+10	μA	$V_{IN} = 0 \text{ to } V_{CC}$ (Note 1)
OD24 Type Buffer						
Low Output Level	V_{OL}			0.4	V	$I_{OL} = 24 \text{ mA}$
Output Leakage	I_{OL}			+10	μA	$V_{IN} = 0 \text{ to } V_{CC}$ (Note 1)
ChiProtect (SLCT, PE, BUSY, nACK, nERROR, GP10-GP17, GP50- GP54, GP60-GP67,)	I_{IL}			± 10	μA	$V_{CC}=0V; V_{CC}=V_{TR}$ $=0V$ $V_{IN} = 6V \text{ Max}$
Backdrive (nSTROBE, nAUTOFD, nINIT, nSLCTIN, PD0-PD7, GP10- GP17, GP50-GP54, GP60- GP67, nSMI, IRQ8)	I_{IL}			± 10	μA	$V_{CC}=0V; V_{CC}=V_{TR}$ $=0V$ $V_{IN} = 6V \text{ Max}$
V_{CC} Supply Current Active	I_{CCI}	4.5	70	90	mA	All outputs open.
Trickle Supply Voltage	V_{TR}	V_{CC} min -.5V		V_{CC} max	V	V_{CC} must not be greater than .5V above V_{TR}
V_{TR} Supply Current Active ³	I_{VRI}			25	mA	All outputs driven
Battery Supply Voltage ³	V_{BAT}	2.4	3.0	4.0	V	
V_{BAT} Supply Current ³ Standby				5	μA	$V_{CC}=V_{TR}=V_{SS}=0V$ $V_{CC}=5V, V_{BAT}=3V$
Input Leakage				100	nA	

Note 1: Output leakage is are measured with the current pins in high impedance.

Note 2: Output leakage is measured with the low driving output off, either for a high level output or a high impedance state.

Note 3: Please contact SMSC for the latest values.

CAPACITANCE $T_A = 25^\circ\text{C}$; $f_c = 1\text{MHz}$; $V_{CC} = 5\text{V}$

PARAMETER	SYMBOL	LIMITS			UNIT	TEST CONDITION
		MIN	TYP	MAX		
Clock Input Capacitance	C_{IN}			20	pF	All pins except pin under test tied to AC ground
Input Capacitance	C_{IN}			10	pF	
Output Capacitance	C_{OUT}			20	pF	

AC TIMING DIAGRAMS

CAPACITIVE LOADING

For the Timing Diagrams shown, the following capacitive loads are used.

TABLE 86 - CAPACITIVE LOADING

NAME	CAPACITANCE TOTAL (pF)
SD[0:7]	120
IOCHRDY	120
IRQ[1,3-12,14,15]	60
DRQ[1:3]	60
nWGATE	240
nWDATA	240
nHDSEL	240
nDIR	240
nSTEP	240
nDS[1:0]	240
nMTR[1:0]	240
DRV DEN[1:0]	240
TXD1	100
nRTS1	100
nDTR1	100
TXD2	100
nRTS2	100
nDTR2	100
PD[0:7]	240
nSLCTIN	240
nINIT	240
nALF	240
nSTB	240
KDAT	240
KCLK	240
MDAT	240
MCLK	240

IOW Timing Port 92

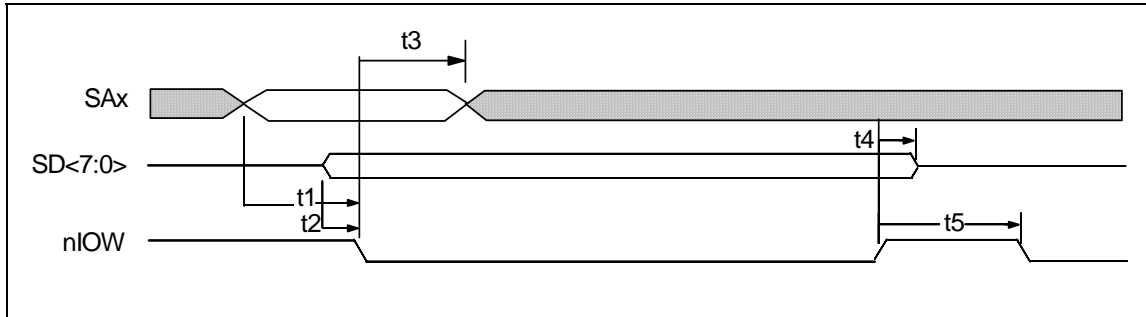

FIGURE 7 - IOW TIMING FOR PORT 92

TABLE 87 - IOW TIMING FOR PORT 92

NAME	DESCRIPTION	MIN	TYP	MAX	UNITS
t1	SAx Valid to nIOW Asserted	40			ns
t2	SDATA Valid to nIOW Asserted	0			ns
t3	nIOW Asserted to SAx Invalid	10			ns
t4	nIOW Deasserted to DATA Invalid	0			ns
t5	nIOW Deasserted to nIOW or nIOR Asserted	100			ns

POWER-UP TIMING

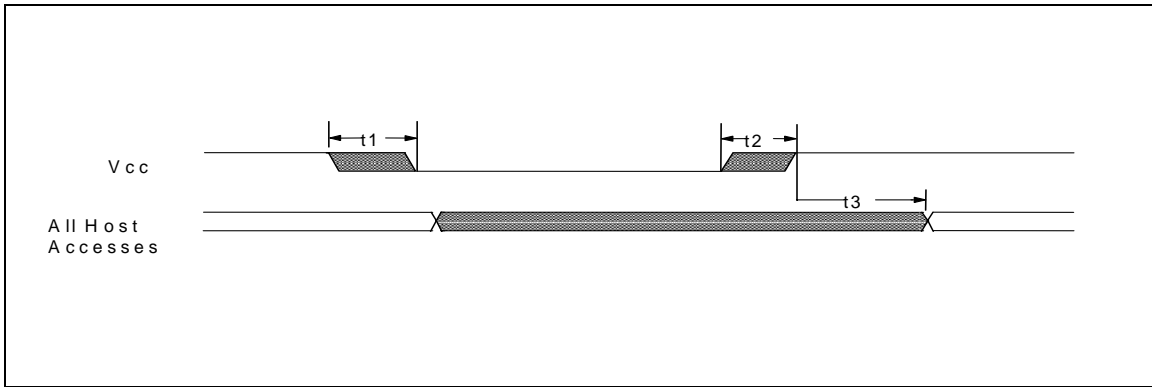

FIGURE 8 - POWER-UP TIMING

TABLE 88 - POWER-UP TIMING

NAME	DESCRIPTION	MIN	TYP	MAX	UNITS
t1	Vcc Slew from 4.5V to 0V	300			μs
t2	Vcc Slew from 0V to 4.5V	100			μs
t3	All Host Accesses After Powerup (Note 1)	125		500	μs

Note 1: Internal write-protection period after Vcc passes 4.5 volts on power-up

Button Timing

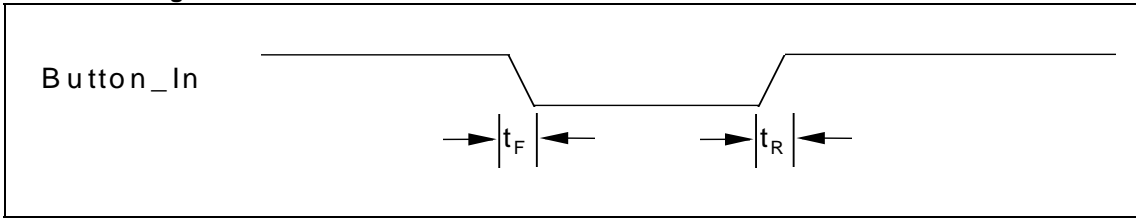

FIGURE 9 - BUTTON INPUT TIMING

TABLE 89 - BUTTON INPUT TIMING

NAME	DESCRIPTION	MIN	TYP	MAX	UNITS
t_R, t_F	Button_In Rise/Fall Time			0.5	μs

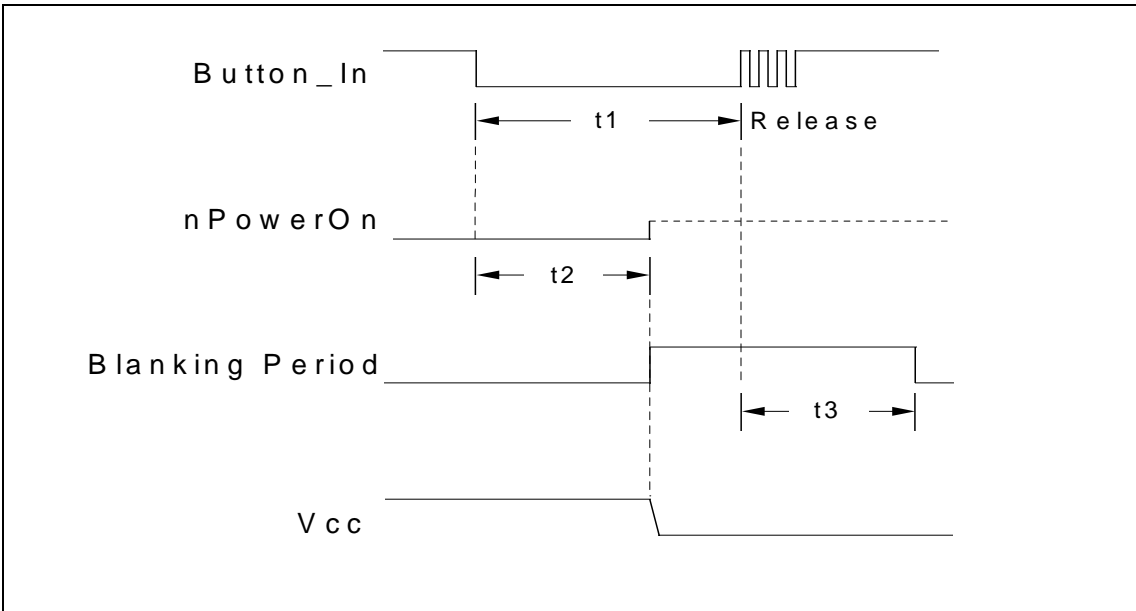

FIGURE 10 - BUTTON OVERRIDE TIMING

TABLE 90 - BUTTON OVERRIDE TIMING

NAME	DESCRIPTION	MIN	TYP	MAX	UNITS
t_1	Button_In Hold Time For Override Event	4			s
t_2	Button_In Low To nPowerOn Tristate and Vcc Low and Start of Blanking Period		4		s
t_3	Blanking Period After Release of Button_In		4		s

ROM INTERFACE

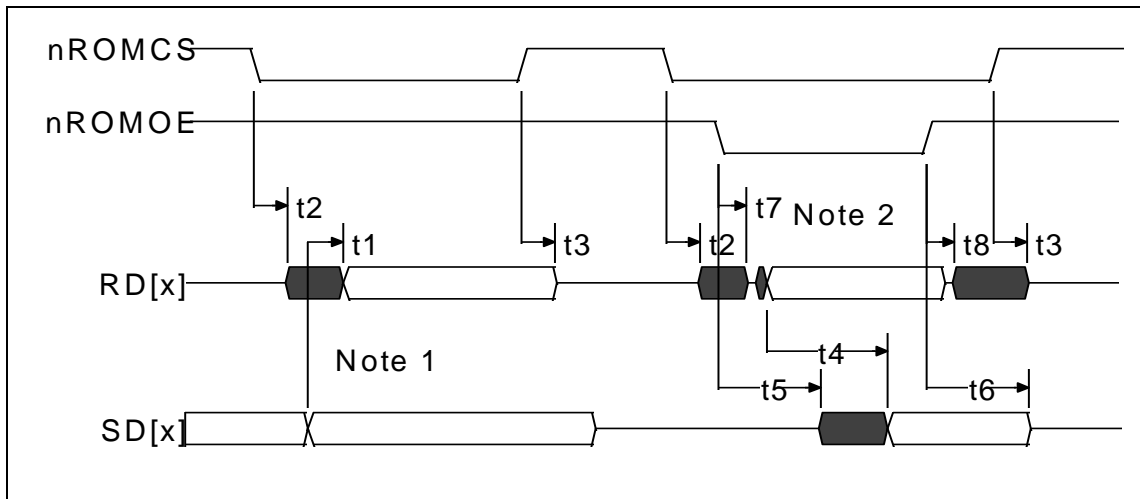

FIGURE 11 - ROM INTERFACE TIMING

Note 1: RD[x] driven by FDC37B78x, SD[x] driven by system

Note 2: RD[x] driven by ROM, SD[x] driven by FDC37B78x

TABLE 91 - ROM INTERFACE TIMING

NAME	DESCRIPTION	MIN	TYP	MAX	UNITS
t1	SD[x] Valid to RD[x] Valid			25	ns
t2	nROMCS Active to RD[X] Driven			25	ns
t3	nROMCS Inactive to RD[X] Float			25	ns
t4	RD[x] Valid to SD[x] Valid			25	ns
t5	nROMCS Active to SD[X] Driven			25	ns
t6	nROMCS Inactive to SD[X] Float			25	ns
t7	nROMOE Active to RD[x] Float			25	ns
t8	nROMOE Inactive to RD[x] Driven			25	ns

Note 1: Outputs have a 50 pf load.

ISA WRITE

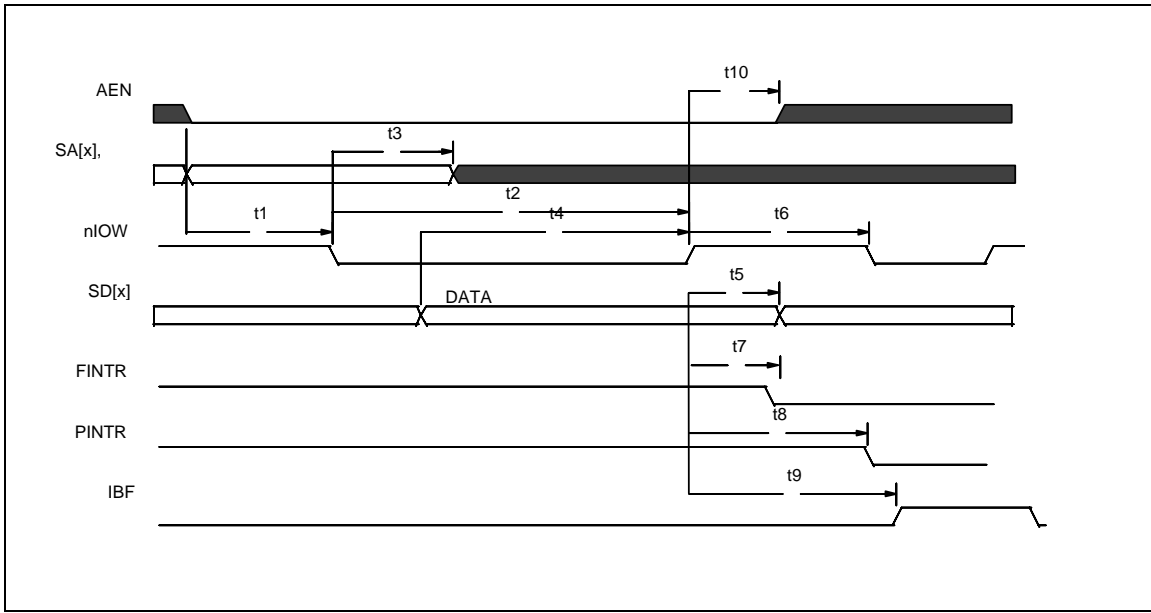

FIGURE 13 - ISA WRITE TIMING

TABLE 92 - ISA WRITE TIMING

NAME	DESCRIPTION	MIN	TYP	MAX	UNITS
t1	SA[x], nCS and AEN valid to nIOW asserted	10			ns
t2	nIOW asserted to nIOW deasserted	80			ns
t3	nIOW asserted to SA[x], nCS invalid	10			ns
t4	SD[x] Valid to nIOW deasserted	45			ns
t5	SD[x] Hold from nIOW deasserted			0	ns
t6	nIOW deasserted to nIOW asserted	25			ns
t7	nIOW deasserted to FINTR deasserted (Note 1)			55	ns
t8	nIOW deasserted to PINTR deasserted (Note 2)			260	ns
t9	IBF (internal signal) asserted from nIOW deasserted			40	ns
t10	nIOW deasserted to AEN invalid	10			ns

Note 1: FINTR refers to the IRQ used by the floppy disk

Note 2: PINTR refers to the IRQ used by the parallel port

ISA READ

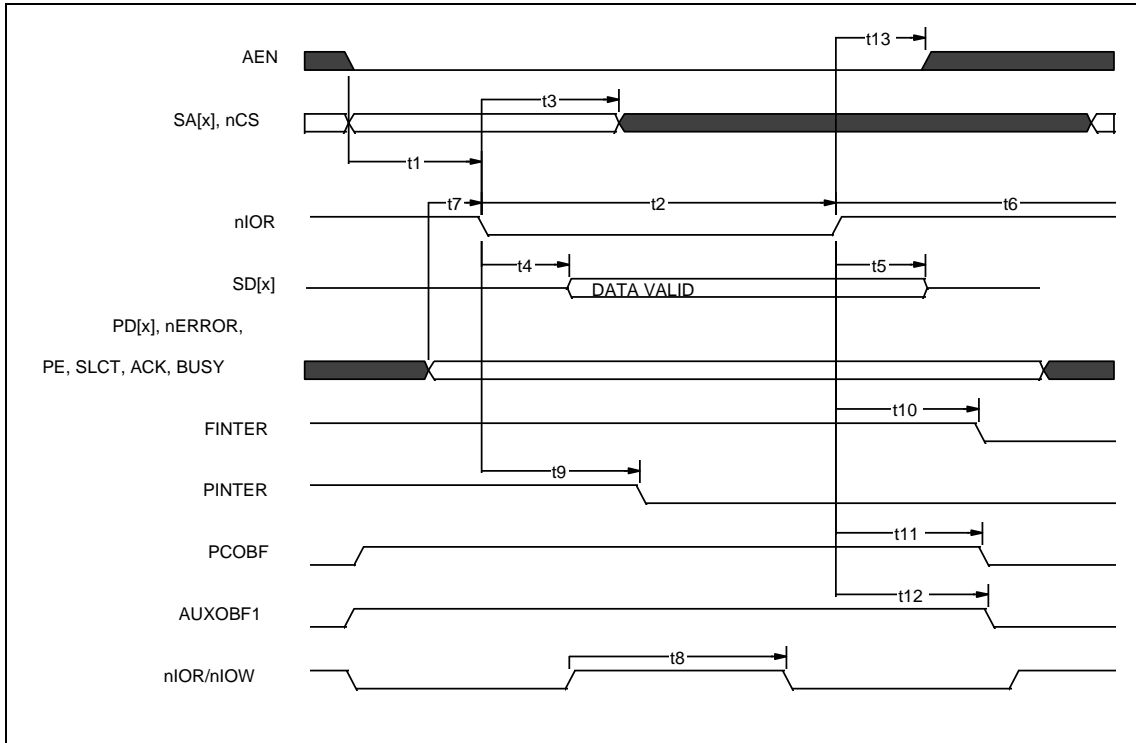

FIGURE 14 - ISA READ TIMING

See timing parameters on next page.

TABLE 93 - ISA READ TIMING

NAME	DESCRIPTION	MIN	TYP	MAX	UNITS
t1	SA[x], nCS and AEN valid to nIOR asserted	10			ns
t2	nIOR asserted to nIOR deasserted	50			ns
t3	nIOR asserted to SA[x], nCS invalid	10			ns
t4	nIOR asserted to Data Valid			50	ns
t5	Data Hold/float from nIOR deasserted	10		25	ns
t6	nIOR deasserted	25			ns
t8	nIOR asserted after nIOW deasserted	80			ns
t8	nIOR/nIOR, nIOW/nIOW transfers from/to ECP FIFO	150			ns
t7	Parallel Port setup to nIOR asserted			20	ns
t9	nIOR asserted to PINTER deasserted			55	ns
t10	nIOR deasserted to FINTER deasserted			260	ns
t11	nIOR deasserted to PCOBF deasserted (Notes 3,5)			80	ns
t12	nIOR deasserted to AUXOBF1 deasserted (Notes 4,5)			80	ns
t13	nIOW deasserted to AEN invalid	10			ns

Note 1: FINTR refers to the IRQ used by the floppy disk.

Note 2: PINTR refers to the IRQ used by the parallel port.

Note 3: PCOBF is used for the Keyboard IRQ.

Note 4: AUXOBF1 is used for the Mouse IRQ.

Note 5: Applies only if deassertion is performed in hardware.

8042 CPU

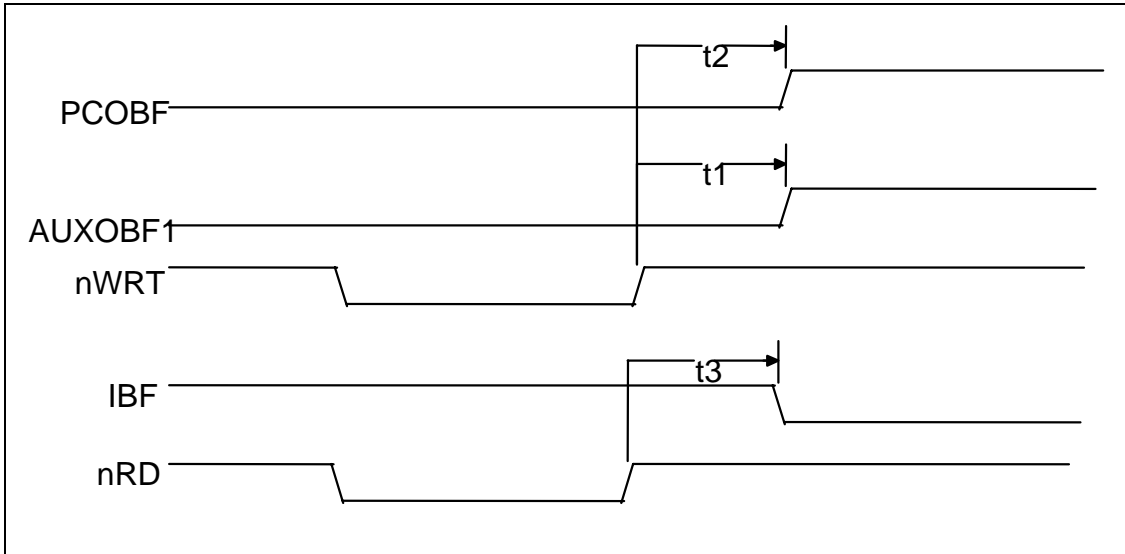

FIGURE 15 - INTERNAL 8042 CPU TIMING

TABLE 94 - INTERNAL 8042 CPU TIMING

NAME	DESCRIPTION	MIN	TYP	MAX	UNITS
t1	nWRT deasserted to AUXOBF1 asserted (Notes 1,2)			40	ns
t2	nWRT deasserted to PCOBF asserted (Notes 1,3)			40	ns
t3	nRD deasserted to IBF deasserted (Note 1)			40	ns

Note 1: IBF, nWRT and nRD are internal signals.

Note 2: PCOBF is used for the Keyboard IRQ.

Note 3: AUXOBF1 is used for the Mouse IRQ.

CLOCK TIMING

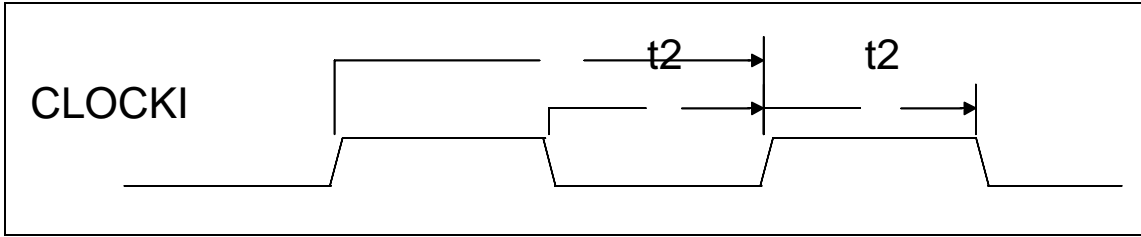

FIGURE 16 - INPUT CLOCK TIMING

TABLE 95 - INPUT CLOCK TIMING

NAME	DESCRIPTION	MIN	TYP	MAX	UNITS
t1	Clock Cycle Time for 14.318MHZ		70		ns
t2	Clock High Time/Low Time for 14.318MHz		35		ns
t1	Clock Cycle Time for 32KHZ		31.25		μs
t2	Clock High Time/Low Time for 32KHz		16.53		μs
	Clock Rise Time/Fall Time (not shown)			5	ns

FIGURE 17 - RESET TIMING

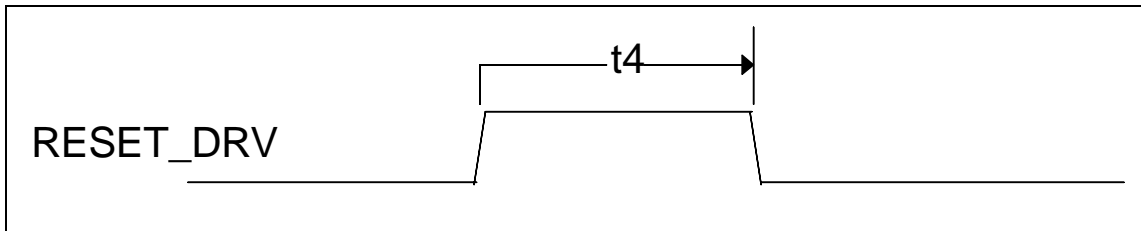

TABLE 96 - RESET TIMING

NAME	DESCRIPTION	MIN	TYP	MAX	UNITS
t4	RESET width (Note 1)	1.5			μs

Note 1: The RESET width is dependent upon the processor clock. The RESET must be active while the clock is running and stable.

Single Transfer DMA

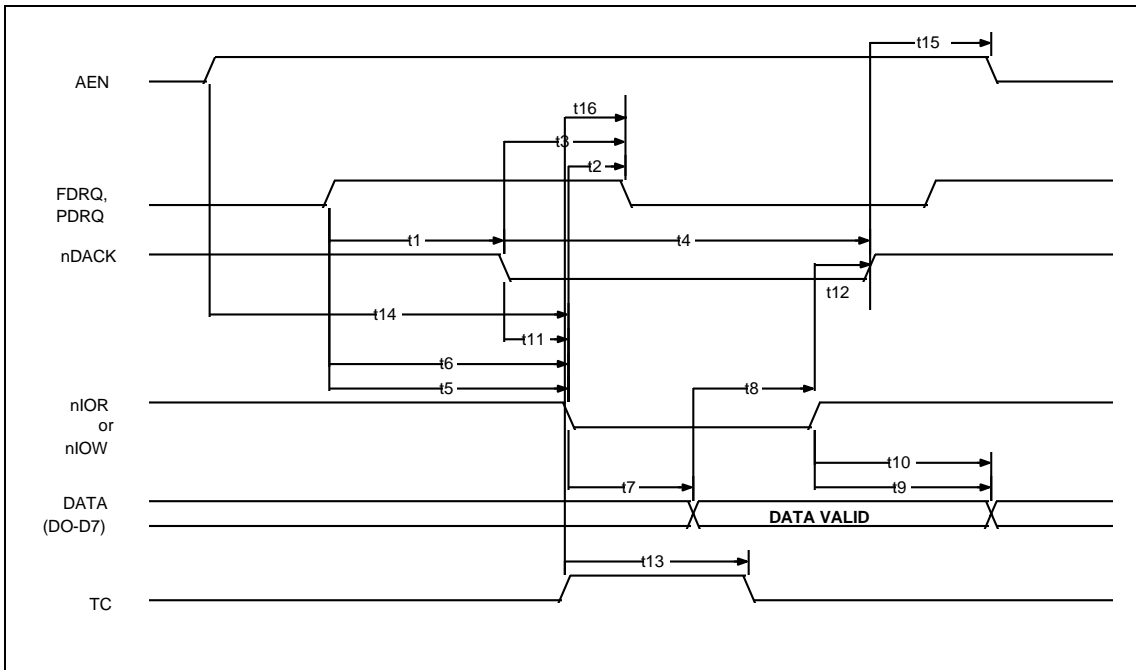

FIGURE 18 - SINGLE TRANSFER DMA TIMING

See timing parameters on next page.

TABLE 97 - SINGLE TRANSFER DMA TIMING

NAME	DESCRIPTION	MIN	TYP	MAX	UNITS
t1	nDACK Delay Time from FDRQ High	0			ns
t2	DRQ Reset Delay from nIOR or nIOW			100	ns
t3	FDRQ Reset Delay from nDACK Low			100	ns
t4	nDACK Width	150			ns
t5	nIOR Delay from FDRQ High	0			ns
t6	nIOW Delay from FDRQ High	0			ns
t7	Data Access Time from nIOR Low			100	ns
t8	Data Set Up Time to nIOW High	40			ns
t9	Data to Float Delay from nIOR High	10		60	ns
t10	Data Hold Time from nIOW High	10			ns
t11	nDACK Set Up to nIOW/nIOR Low	5			ns
t12	nDACK Hold after nIOW/nIOR High	10			ns
t13	TC Pulse Width	60			ns
t14	AEN Set Up to nIOR/nIOW	40			ns
t15	AEN Hold from nDACK	10			ns
t16	TC Active to PDRQ Inactive			100	ns

Burst Transfer DMA Timing

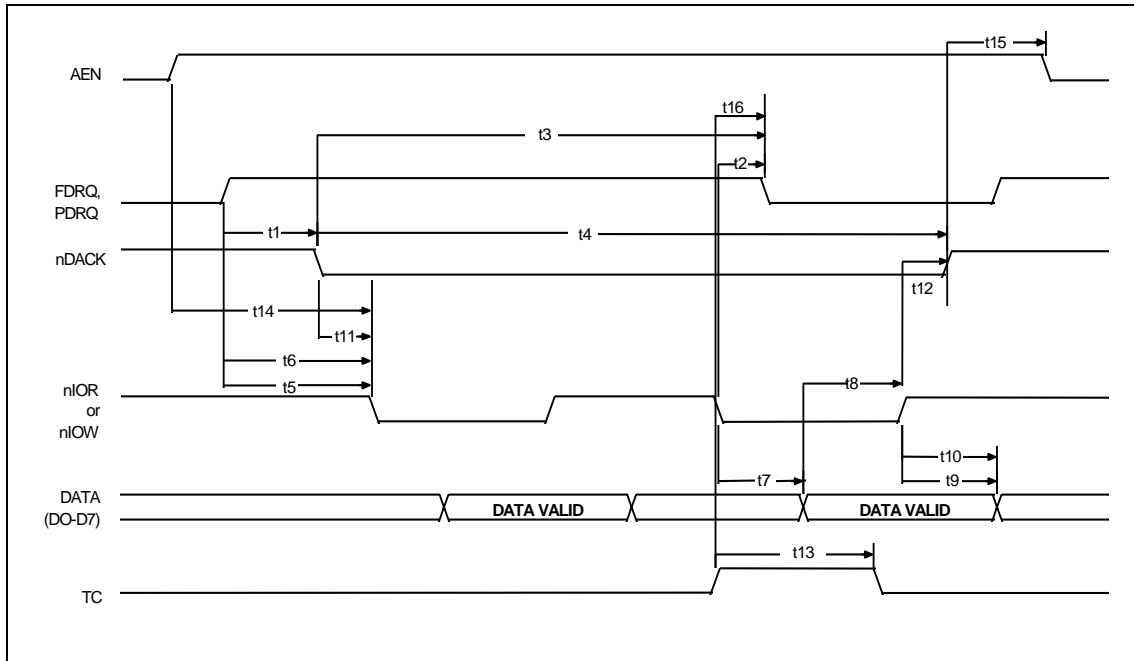

FIGURE 19 - BURST TRANSFER DMA TIMING

See timing parameters on next page.

TABLE 98 - BURST TRANSFER DMA TIMING

NAME	DESCRIPTION	MIN	TYP	MAX	UNITS
t1	nDACK Delay Time from FDRQ High	0			ns
t2	DRQ Reset Delay from nIOR or nIOW			100	ns
t3	FDRQ Reset Delay from nDACK Low			100	ns
t4	nDACK Width	150			ns
t5	nIOR Delay from FDRQ High	0			ns
t6	nIOW Delay from FDRQ High	0			ns
t7	Data Access Time from nIOR Low			100	ns
t8	Data Set Up Time to nIOW High	40			ns
t9	Data to Float Delay from nIOR High	10		60	ns
t10	Data Hold Time from nIOW High	10			ns
t11	nDACK Set Up to nIOW/nIOR Low	5			ns
t12	nDACK Hold after nIOW/nIOR High	10			ns
t13	TC Pulse Width	60			ns
t14	AEN Set Up to nIOR/nIOW	40			ns
t15	AEN Hold from nDACK	10			ns
t16	TC Active to PDRQ Inactive			100	ns

DISK DRIVE TIMING

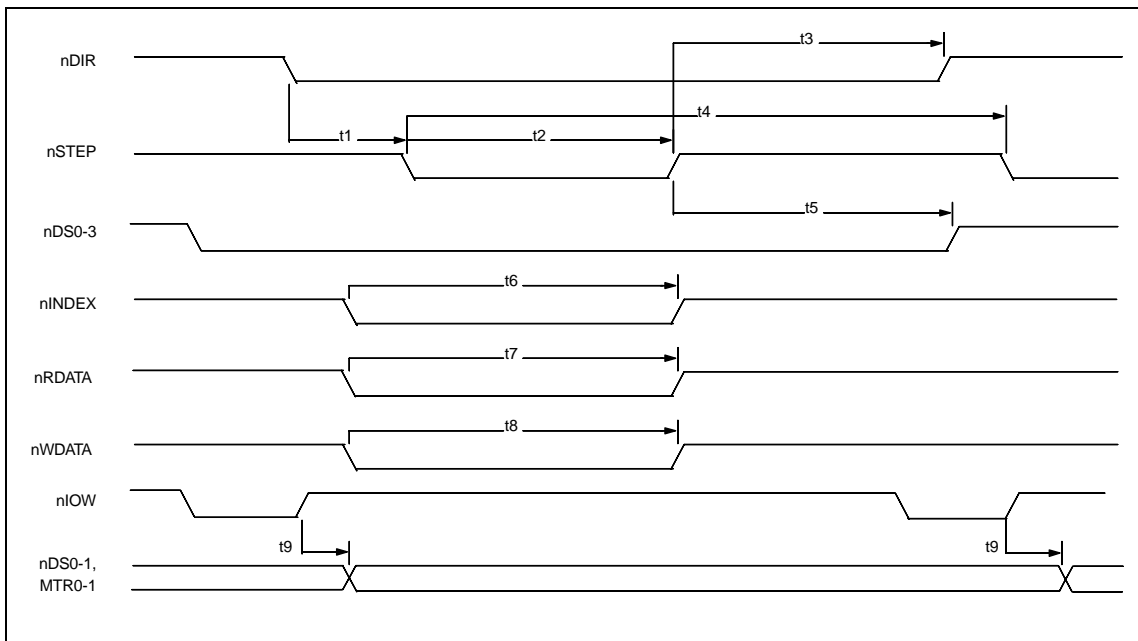

FIGURE 20 - DISK DRIVE TIMING (AT MODE ONLY)

TABLE 99 - DISK DRIVE TIMING (AT MODE ONLY)

NAME	DESCRIPTION	MIN	TYP	MAX	UNITS
t1	nDIR Set Up to STEP Low		4		X*
t2	nSTEP Active Time Low		24		X*
t3	nDIR Hold Time after nSTEP		96		X*
t4	nSTEP Cycle Time		132		X*
t5	nDS0-1 Hold Time from nSTEP Low		20		X*
t6	nINDEX Pulse Width		2		X*
t7	nRDATA Active Time Low		40		ns
t8	nWDATA Write Data Width Low		.5		Y*
t9	nDS0-1, MTR0-1 from End of nLOW		25		ns

*X specifies one MCLK period and Y specifies one WCLK period.

MCLK = 16 x Data Rate (at 500 kb/s MCLK = 8 MHz)

WCLK = 2 x Data Rate (at 500 kb/s WCLK = 1 MHz)

SERIAL PORT

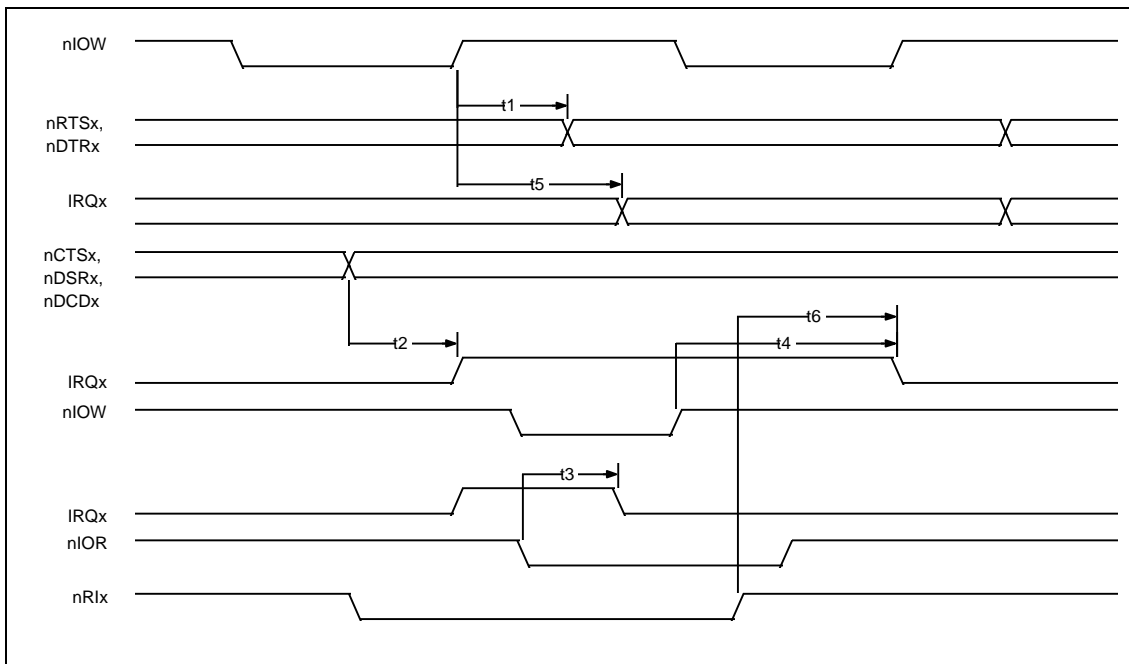

FIGURE 21 - SERIAL PORT TIMING

TABLE 100 - SERIAL PORT TIMING

NAME	DESCRIPTION	MIN	TYP	MAX	UNITS
t1	nRTSx, nDTRx Delay from nIOW			200	ns
t2	IRQx Active Delay from nCTSx, nDSRx, nDCDx			100	ns
t3	IRQx Inactive Delay from nIOR (Leading Edge)			120	ns
t4	IRQx Inactive Delay from nIOW (Trailing Edge)			125	ns
t5	IRQx Inactive Delay from nIOW	10		100	ns
t6	IRQx Active Delay from nRIx			100	ns

Parallel Port

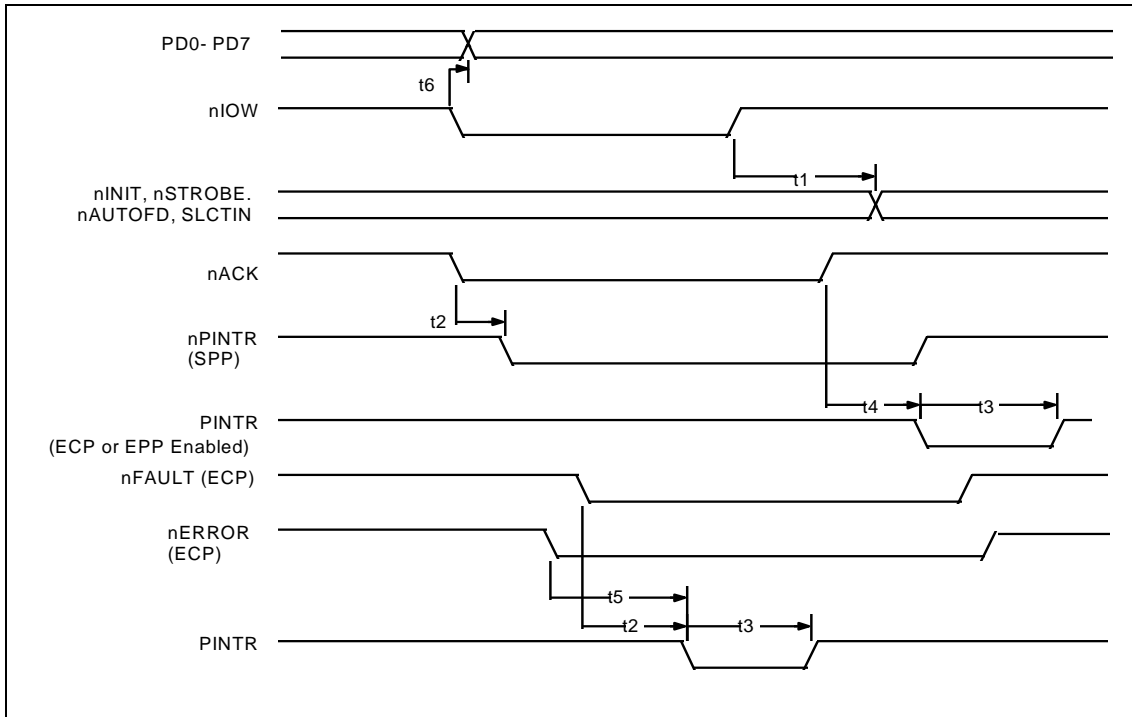

FIGURE 22 - PARALLEL PORT TIMING

TABLE 101 - PARALLEL PORT TIMING

NAME	DESCRIPTION	MIN	TYP	MAX	UNITS
t1	PD0-7, nINIT, nSTROBE, nAUTOFD Delay from nIOW			100	ns
t2	PINTR Delay from nACK, nFAULT			60	ns
t3	PINTR Active Low in ECP and EPP Modes	200		300	ns
t4	PINTR Delay from nACK			105	ns
t5	nERROR Active to PINTR Active			105	ns
t6	PD0 - PD7 Delay from IOW Active			100	ns

Note PINTR refers to the IRQ used by the parallel port.

EPP 1.9 Data or Address Write Cycle

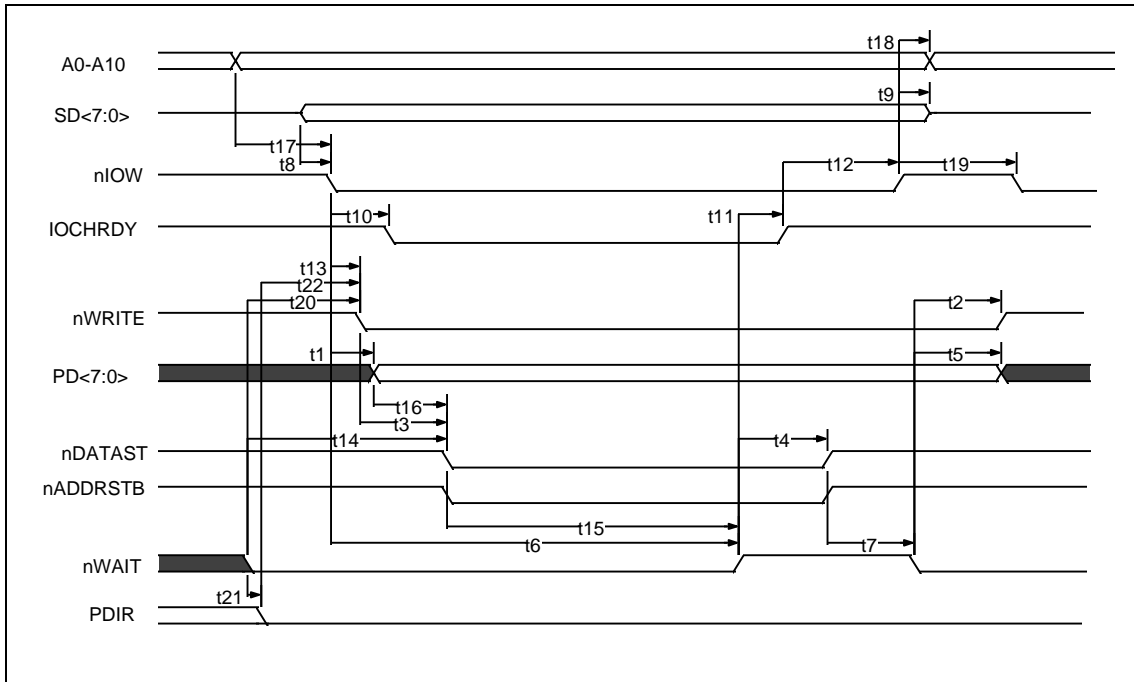

FIGURE 23 - EPP 1.9 DATA OR ADDRESS WRITE CYCLE

See timing parameters on next page.

TABLE 102 - EPP 1.9 DATA OR ADDRESS WRITE CYCLE TIMING

NAME	DESCRIPTION	MIN	TYP	MAX	UNITS
t1	nIOW Asserted to PDATA Valid	0		50	ns
t2	nWAIT Asserted to nWRITE Change (Note 1)	60		185	ns
t3	nWRITE to Command Asserted	5		35	ns
t4	nWAIT Deasserted to Command Deasserted (Note 1)	60		190	ns
t5	nWAIT Asserted to PDATA Invalid (Note 1)	0			ns
t6	Time Out	10		12	s
t7	Command Deasserted to nWAIT Asserted	0			ns
t8	SDATA Valid to nIOW Asserted	10			ns
t9	nIOW Deasserted to DATA Invalid	0			ns
t10	nIOW Asserted to IOCHRDY Asserted	0		24	ns
t11	nWAIT Deasserted to IOCHRDY Deasserted (Note 1)	60		160	ns
t12	IOCHRDY Deasserted to nIOW Deasserted	10			ns
t13	nIOW Asserted to nWRITE Asserted	0		70	ns
t14	nWAIT Asserted to Command Asserted (Note 1)	60		210	ns
t15	Command Asserted to nWAIT Deasserted	0		10	s
t16	PDATA Valid to Command Asserted	10			ns
t17	Ax Valid to nIOW Asserted	40			ns
t18	nIOW Asserted to Ax Invalid	10			ns
t19	nIOW Deasserted to nIOW or nIOR Asserted	40			ns
t20	nWAIT Asserted to nWRITE Asserted (Note 1)	60		185	ns
t21	nWAIT Asserted to PDIR Low	0			ns
t22	PDIR Low to nWRITE Asserted	0			ns

Note 1: nWAIT must be filtered to compensate for ringing on the parallel bus cable. WAIT is considered to have settled after it does not transition for a minimum of 50 nsec.

EPP 1.9 Data or Address Read Cycle

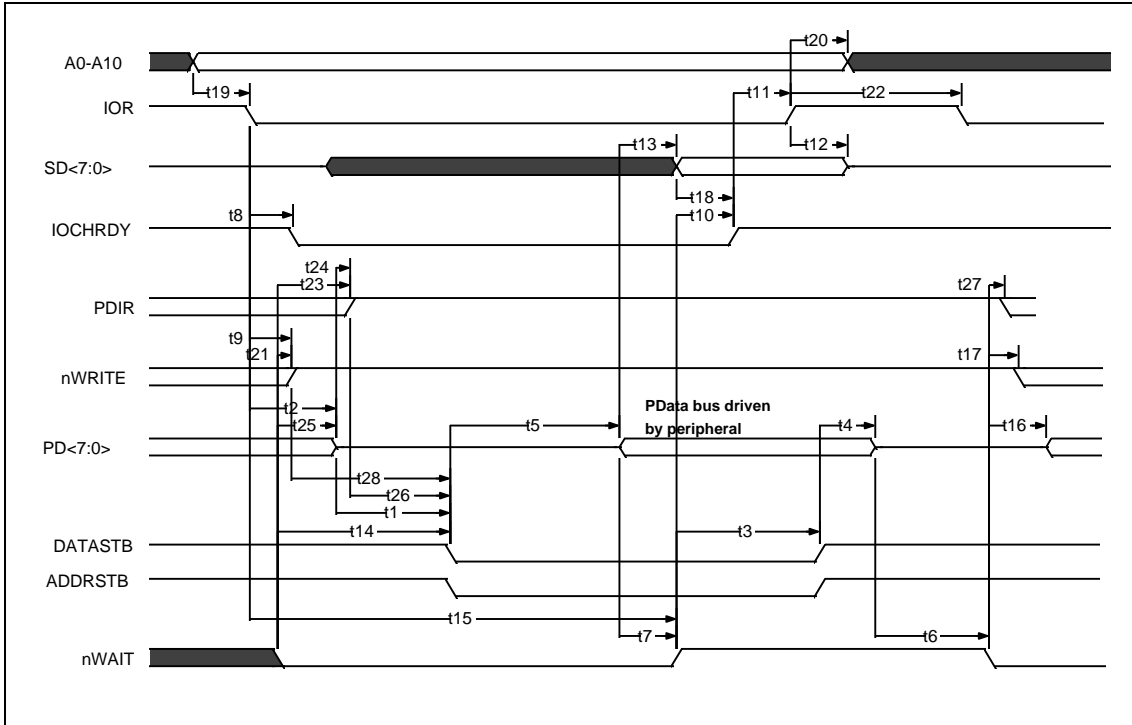

FIGURE 24 - EPP 1.9 DATA OR ADDRESS READ CYCLE

See timing parameters on next page

TABLE 103 - EPP 1.9 DATA OR ADDRESS READ CYCLE TIMING

NAME	DESCRIPTION	MIN	TYP	MAX	UNITS
t1	PDATA Hi-Z to Command Asserted	0		30	ns
t2	nIOR Asserted to PDATA Hi-Z	0		50	ns
t3	nWAIT Deasserted to Command Deasserted (Note 1)	60		180	ns
t4	Command Deasserted to PDATA Hi-Z	0			ns
t5	Command Asserted to PDATA Valid	0			ns
t6	PDATA Hi-Z to nWAIT Deasserted	0			s
t7	PDATA Valid to nWAIT Deasserted	0			ns
t8	nIOR Asserted to IOCHRDY Asserted	0		24	ns
t9	nWRITE Deasserted to nIOR Asserted (Note 2)	0			ns
t10	nWAIT Deasserted to IOCHRDY Deasserted (Note 1)	60		160	ns
t11	IOCHRDY Deasserted to nIOR Deasserted	0			ns
t12	nIOR Deasserted to SDATA Hi-Z (Hold Time)	0		40	ns
t13	PDATA Valid to SDATA Valid	0		75	ns
t14	nWAIT Asserted to Command Asserted	0		195	ns
t15	Time Out	10		12	s
t16	nWAIT Deasserted to PDATA Driven (Note 1)	60		190	ns
t17	nWAIT Deasserted to nWRITE Modified (Notes 1,2)	60		190	ns
t18	SDATA Valid to IOCHRDY Deasserted (Note 3)	0		85	ns
t19	Ax Valid to nIOR Asserted	40			ns
t20	nIOR Deasserted to Ax Invalid	10		10	ns
t21	nWAIT Asserted to nWRITE Deasserted	0		185	ns
t22	nIOR Deasserted to nIOW or nIOR Asserted	40			ns
t23	nWAIT Asserted to PDIR Set (Note 1)	60		185	ns
t24	PDATA Hi-Z to PDIR Set	0			ns
t25	nWAIT Asserted to PDATA Hi-Z (Note 1)	60		180	ns
t26	PDIR Set to Command	0		20	ns
t27	nWAIT Deasserted to PDIR Low (Note 1)	60		180	ns
t28	nWRITE Deasserted to Command	1			ns

Note 1 nWAIT is considered to have settled after it does not transition for a minimum of 50 ns.

Note 2 When not executing a write cycle, EPP nWRITE is inactive high.

Note 3 85 is true only if t7 = 0.

EPP 1.7 Data Or Address Write Cycle

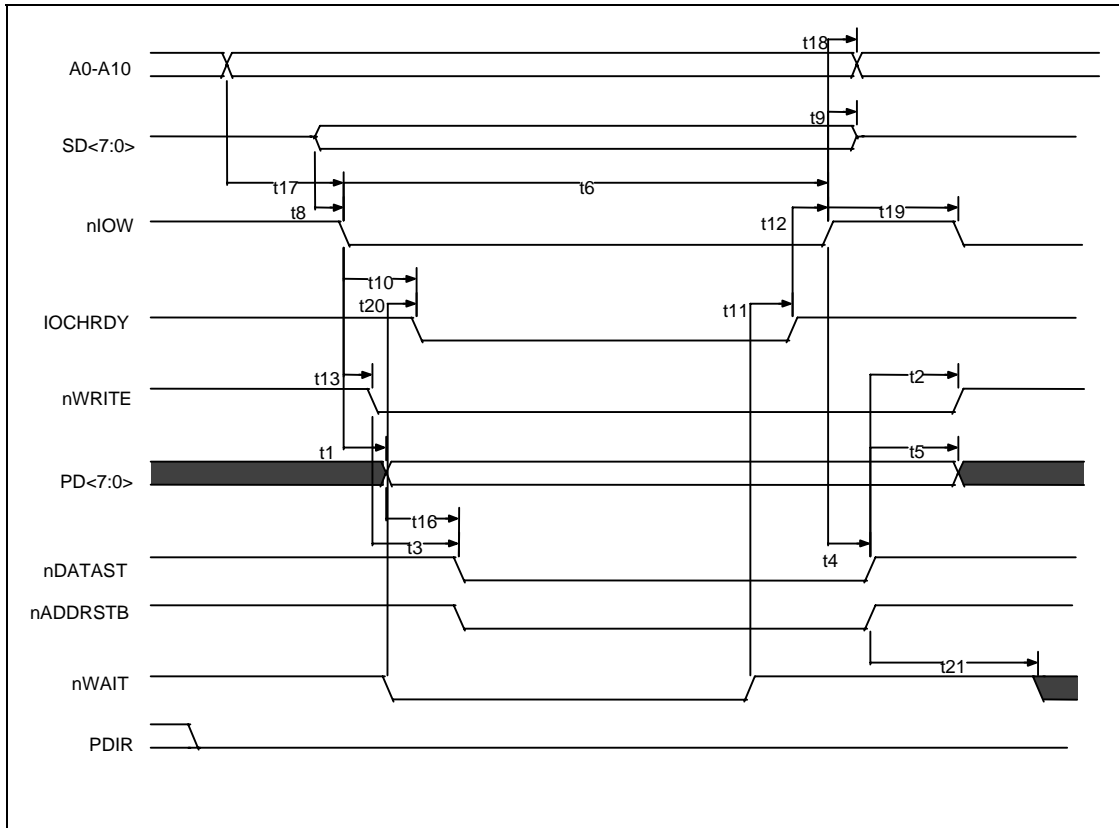

FIGURE 25 - EPP 1.7 DATA OR ADDRESS WRITE CYCLE

See timing parameters on next page.

TABLE 104 - EPP 1.7 DATA OR ADDRESS WRITE CYCLE TIMING

NAME	DESCRIPTION	MIN	TYP	MAX	UNITS
t1	nIOW Asserted to PDATA Valid	0		50	ns
t2	Command Deasserted to nWRITE Change	0		40	ns
t3	nWRITE to Command	5		35	ns
t4	nIOW Deasserted to Command Deasserted (Note 2)			50	ns
t5	Command Deasserted to PDATA Invalid	50			ns
t6	Time Out	10		12	s
t8	SDATA Valid to nIOW Asserted	10			ns
t9	nIOW Deasserted to DATA Invalid	0			ns
t10	nIOW Asserted to IOCHRDY Asserted	0		24	ns
t11	nWAIT Deasserted to IOCHRDY Deasserted			40	ns
t12	IOCHRDY Deasserted to nIOW Deasserted	10			ns
t13	nIOW Asserted to nWRITE Asserted	0		50	ns
t16	PDATA Valid to Command Asserted	10		35	ns
t17	Ax Valid to nIOW Asserted	40			ns
t18	nIOW Deasserted to Ax Invalid	10			s
t19	nIOW Deasserted to nIOW or nIOR Asserted	100			ns
t20	nWAIT Asserted to IOCHRDY Deasserted			45	ns
t21	Command Deasserted to nWAIT Deasserted	0			ns

Note 1 nWRITE is controlled by clearing the PDIR bit to "0" in the control register before performing an EPP Write.

Note 2 The number is only valid if nWAIT is active when IOW goes active.

EPP 1.7 Data or Address Read Cycle

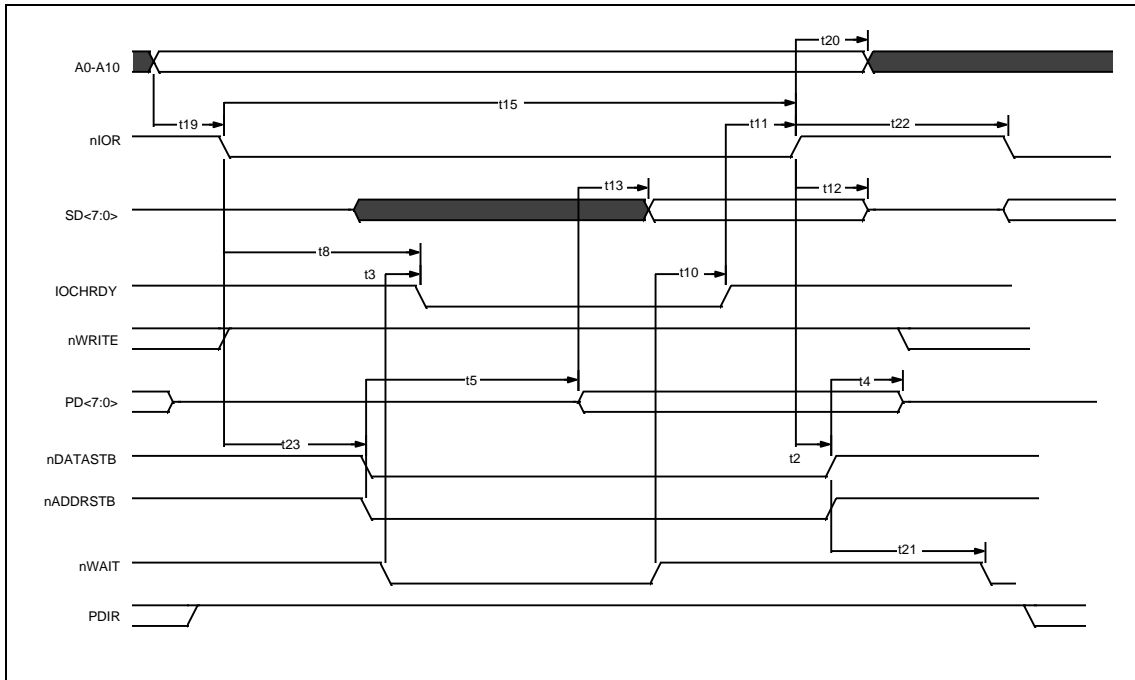

FIGURE 26 - EPP 1.7 DATA OR ADDRESS READ CYCLE

See timing parameters on next page.

TABLE 105 - EPP 1.7 DAT OR ADDRESS READ CYCLE TIMING

NAME	DESCRIPTION	MIN	TYP	MAX	UNITS
t2	nIOR Deasserted to Command Deasserted			50	ns
t3	nWAIT Asserted to IOCHRDY Deasserted	0		40	ns
t4	Command Deasserted to PDATA Hi-Z	0			ns
t5	Command Asserted to PDATA Valid	0			ns
t8	nIOR Asserted to IOCHRDY Asserted			24	ns
t10	nWAIT Deasserted to IOCHRDY Deasserted			50	ns
t11	IOCHRDY Deasserted to nIOR Deasserted	0			ns
t12	nIOR Deasserted to SDATA High-Z (Hold Time)	0		40	ns
t13	PDATA Valid to SDATA Valid			40	ns
t15	Time Out	10		12	s
t19	Ax Valid to nIOR Asserted	40			ns
t20	nIOR Deasserted to Ax Invalid	10			ns
t21	Command Deasserted to nWAIT Deasserted	0			ns
t22	nIOR Deasserted to nIOW or nIOR Asserted	40			ns
t23	nIOR Asserted to Command Asserted			55	ns

Note: WRITE is controlled by setting the PDIR bit to "1" in the control register before performing an EPP Read.

ECP PARALLEL PORT TIMING

Parallel Port FIFO (Mode 101)

The standard parallel port is run at or near the peak 500KBytes/sec allowed in the forward direction using DMA. The state machine does not examine nACK and begins the next transfer based on Busy. Refer to **FIGURE 28**.

ECP Parallel Port Timing

The timing is designed to allow operation at approximately 2.0 Mbytes/sec over a 15ft cable. If a shorter cable is used then the bandwidth will increase.

Forward-Idle

When the host has no data to send it keeps HostClk (nStrobe) high and the peripheral will leave PeriphClk (Busy) low.

Forward Data Transfer Phase

The interface transfers data and commands from the host to the peripheral using an interlocked PeriphAck and HostClk. The peripheral may indicate its desire to send data to the host by asserting nPeriphRequest.

The Forward Data Transfer Phase may be entered from the Forward-Idle Phase. While in the Forward Phase the peripheral may asynchronously assert the nPeriphRequest (nFault) to request that the channel be reversed. When the peripheral is not busy it sets PeriphAck (Busy) low. The host then sets HostClk (nStrobe) low when it is prepared to send data. The data must be stable for the specified setup time prior to the falling edge of HostClk. The peripheral then sets PeriphAck (Busy) high to acknowledge the handshake. The host then sets HostClk (nStrobe) high. The peripheral then accepts the data and sets PeriphAck (Busy) low, completing the transfer. This sequence is shown in **FIGURE 28**.

The timing is designed to provide 3 cable round-trip times for data setup if Data is driven simultaneously with HostClk (nStrobe).

Reverse-Idle Phase

The peripheral has no data to send and keeps PeriphClk high. The host is idle and keeps HostAck low.

Reverse Data Transfer Phase

The interface transfers data and commands from the peripheral to the host using an interlocked HostAck and PeriphClk. The Reverse Data Transfer Phase may be entered from the Reverse-Idle Phase. After the previous byte has been accepted the host sets HostAck (nALF) low. The peripheral then sets PeriphClk (nACK) low when it has data to send. The data must be stable for the specified setup time prior to the falling edge of PeriphClk. When the host is ready to accept a byte it sets HostAck (nALF) high to acknowledge the handshake. The peripheral then sets PeriphClk (nACK) high. After the host has accepted the data it sets HostAck (nALF) low, completing the transfer. This sequence is shown in **FIGURE 29**.

Output Drivers

To facilitate higher performance data transfer, the use of balanced CMOS active drivers for critical signals (Data, HostAck, HostClk, PeriphAck, PeriphClk) are used ECP Mode. Because the use of active drivers can present compatibility problems in Compatible Mode (the control signals, by tradition, are specified as open-collector), the drivers are dynamically changed from open-collector to totem-pole. The timing for the dynamic driver change is specified in the [IEEE 1284 Extended Capabilities Port Protocol and ISA Interface Standard](#), Rev. 1.14, July 14, 1993, available from Microsoft. The dynamic driver change must be implemented properly to prevent glitching the outputs.

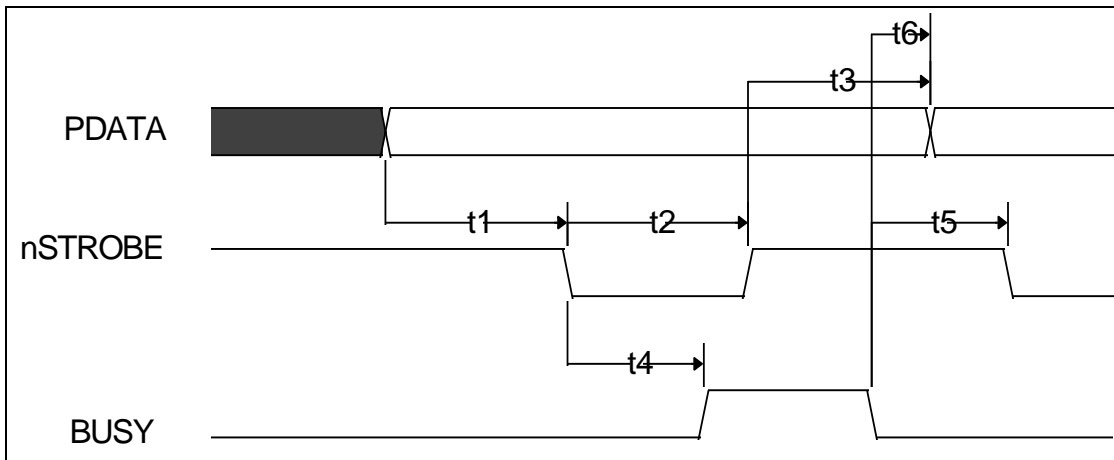

FIGURE 27 - PARALLEL PORT FIFO TIMING

TABLE 106 - PARALLEL PORT FIFO TIMING

NAME	DESCRIPTION	MIN	TYP	MAX	UNITS
t1	DATA Valid to nSTROBE Active	600			ns
t2	nSTROBE Active Pulse Width	600			ns
t3	DATA Hold from nSTROBE Inactive (Note 1)	450			ns
t4	nSTROBE Active to BUSY Active			500	ns
t5	BUSY Inactive to nSTROBE Active	680			ns
t6	BUSY Inactive to PDATA Invalid (Note 1)	80			ns

Note 1: The data is held until BUSY goes inactive or for time t3, whichever is longer. This only applies if another data transfer is pending. If no other data transfer is pending, the data is held indefinitely.

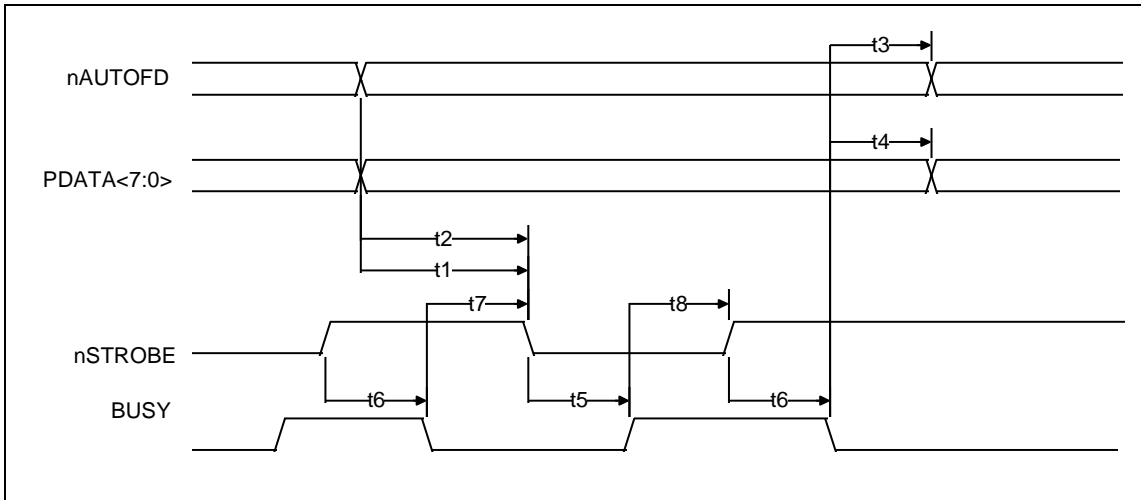

FIGURE 28 - ECP PARALLEL PORT FORWARD TIMING

TABLE 107 - ECP PARALLEL PORT FORWARD TIMING

NAME	DESCRIPTION	MIN	TYP	MAX	UNITS
t1	nAUTOFD Valid to nSTROBE Asserted	0		60	ns
t2	PDATA Valid to nSTROBE Asserted	0		60	ns
t3	BUSY Deasserted to nAUTOFD Changed (Notes 1,2)	80		180	ns
t4	BUSY Deasserted to PDATA Changed (Notes 1,2)	80		180	ns
t5	nSTROBE Deasserted to Busy Asserted	0			ns
t6	nSTROBE Deasserted to Busy Deasserted	0			ns
t7	BUSY Deasserted to nSTROBE Asserted (Notes 1,2)	80		200	ns
t8	BUSY Asserted to nSTROBE Deasserted (Note 2)	80		180	ns

Note 1 Maximum value only applies if there is data in the FIFO waiting to be written out.

Note 2 BUSY is not considered asserted or deasserted until it is stable for a minimum of 75 to 130 ns.

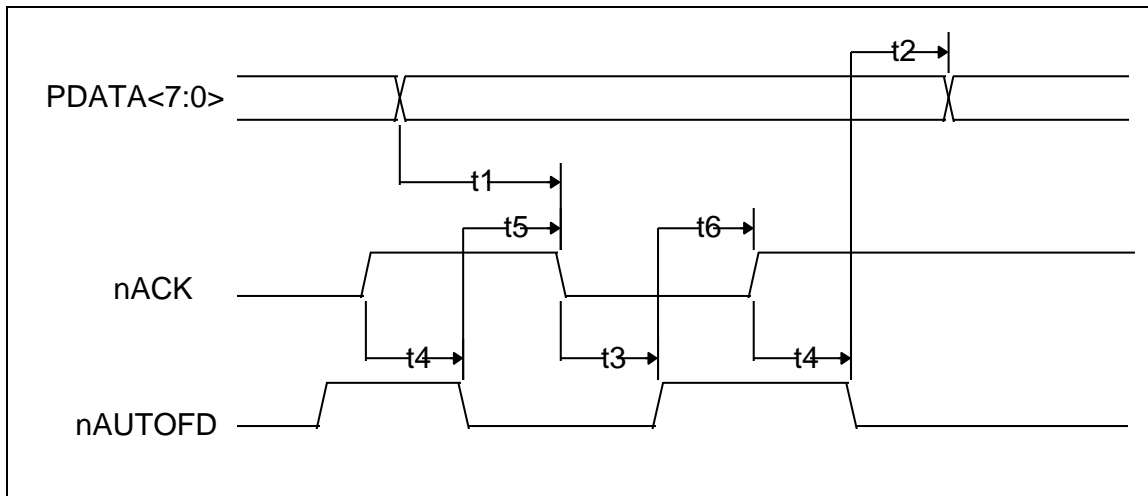

FIGURE 29 - ECP PARALLEL PORT REVERSE TIMING

TABLE 108 - ECP PARALLEL PORT REVERSE TIMING

NAME	DESCRIPTION	MIN	TYP	MAX	UNITS
t1	PDATA Valid to nACK Asserted	0			ns
t2	nAUTOFD Deasserted to PDATA Changed	0			ns
t3	nACK Asserted to nAUTOFD Deasserted (Notes 1,2)	80		200	ns
t4	nACK Deasserted to nAUTOFD Asserted (Note 2)	80		200	ns
t5	nAUTOFD Asserted to nACK Asserted	0			ns
t6	nAUTOFD Deasserted to nACK Deasserted	0			ns

Note 1 Maximum value only applies if there is room in the FIFO and terminal count has not been received. ECP can stall by keeping nAUTOFD low.

Note 2 nACK is not considered asserted or deasserted until it is stable for a minimum of 75 to 130 ns.

Serial Port Infrared Timing

IRDA SIR RECEIVE

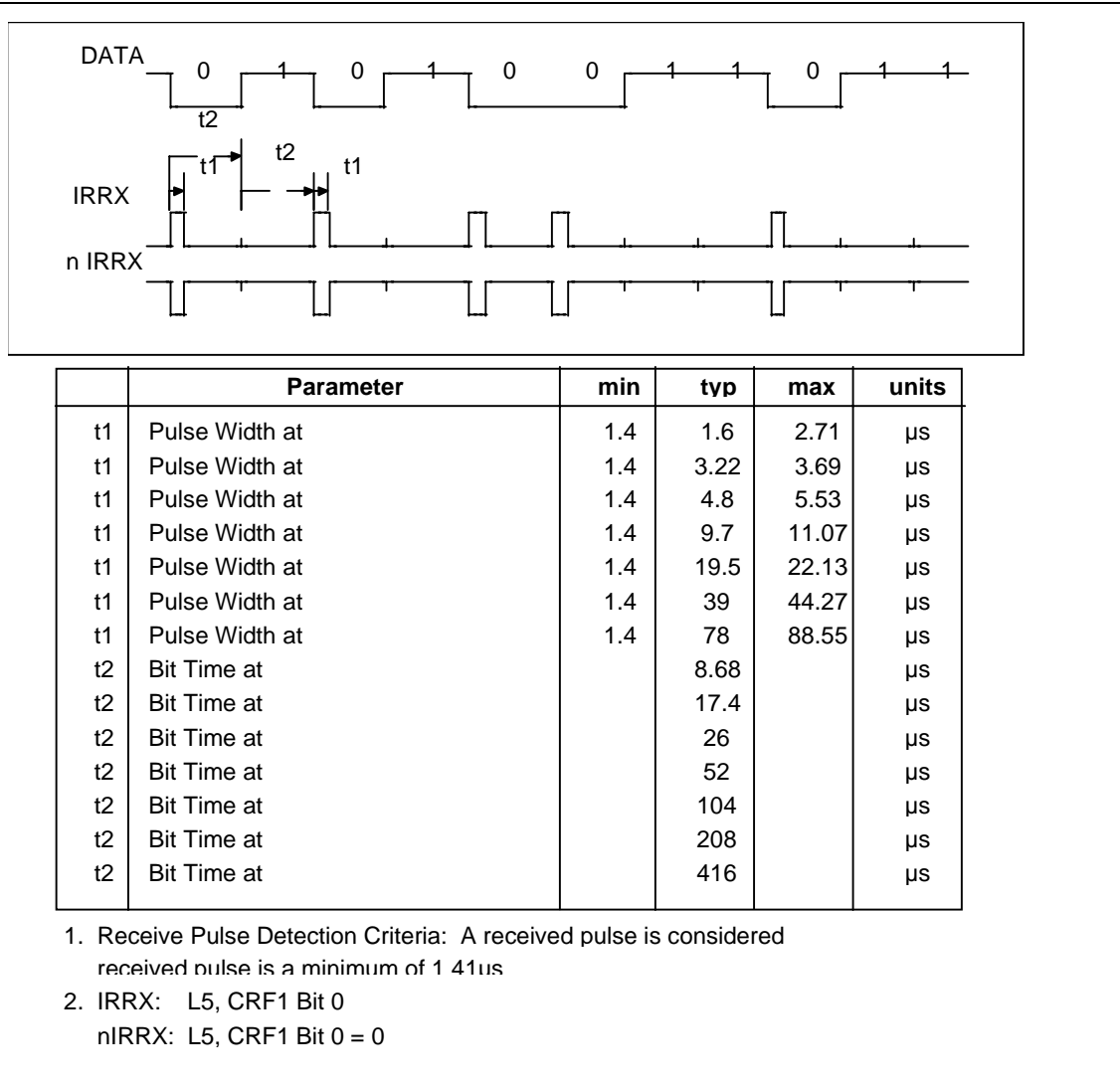
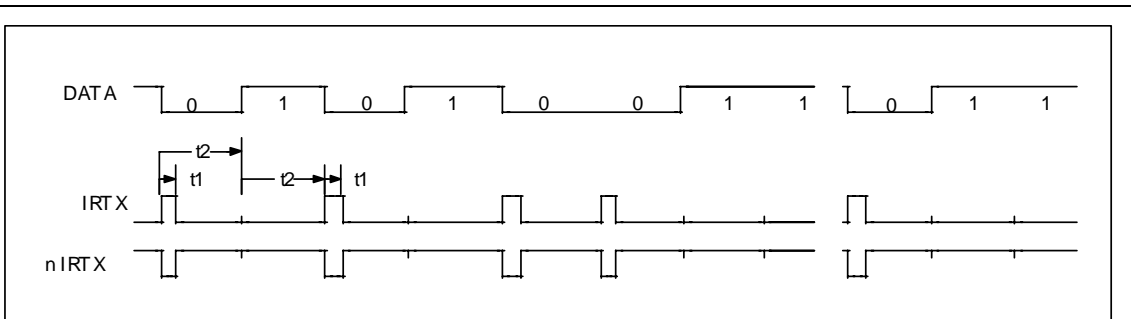

FIGURE 30 - IRDA SIR RECEIVE TIMING

IRDA SIR TRANSMIT



	Parameter	min	typ	max	units
t1	Pulse Width at 115kbaud	1.41	1.6	2.71	μs
t1	Pulse Width at 57.6kbaud	1.41	3.22	3.69	μs
t1	Pulse Width at 38.4kbaud	1.41	4.8	5.53	μs
t1	Pulse Width at 19.2kbaud	1.41	9.7	11.07	μs
t1	Pulse Width at 9.6kbaud	1.41	19.5	22.13	μs
t1	Pulse Width at 4.8kbaud	1.41	39	44.27	μs
t1	Pulse Width at 2.4kbaud	1.41	78	88.55	μs
t2	Bit Time at 115kbaud		8.68		μs
t2	Bit Time at 57.6kbaud		17.4		μs
t2	Bit Time at 38.4kbaud		26		μs
t2	Bit Time at 19.2kbaud		52		μs
t2	Bit Time at 9.6kbaud		104		μs
t2	Bit Time at 4.8kbaud		208		μs
t2	Bit Time at 2.4kbaud		416		μs

Notes:

1. IrDA @ 115k is HPSIR compatible. IrDA @ 2400 will allow compatibility with HP95LX and 48SX.
2. IRTX: L5, CRF1 Bit 1 = 1 (default)
nIRTX: L5, CRF1 Bit 1 = 0

FIGURE 31 - IRDA SIR TRANSMIT TIMING

ASK IR Receive

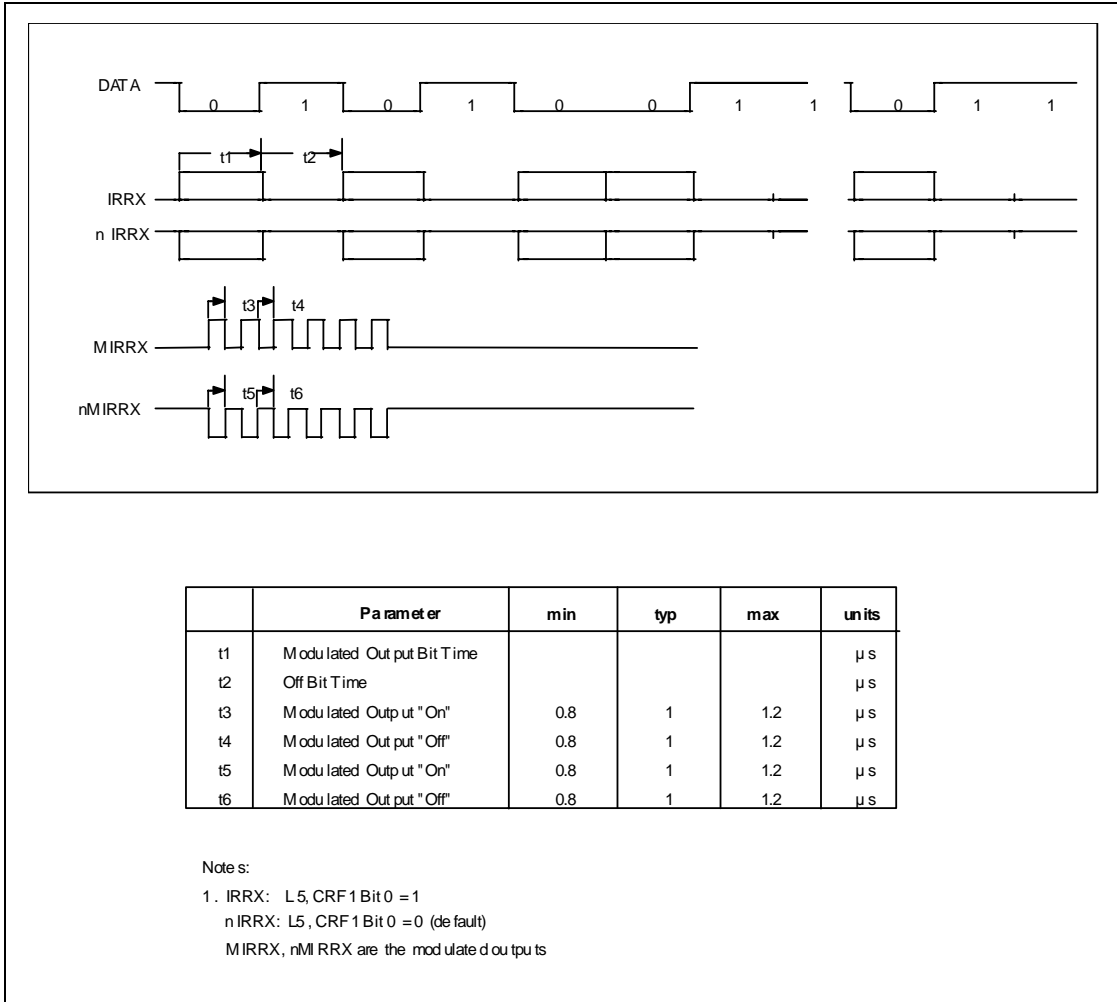

FIGURE 32 - AMPLITUDE SHIFT KEYED IR RECEIVE TIMING

ASK IR Transmit

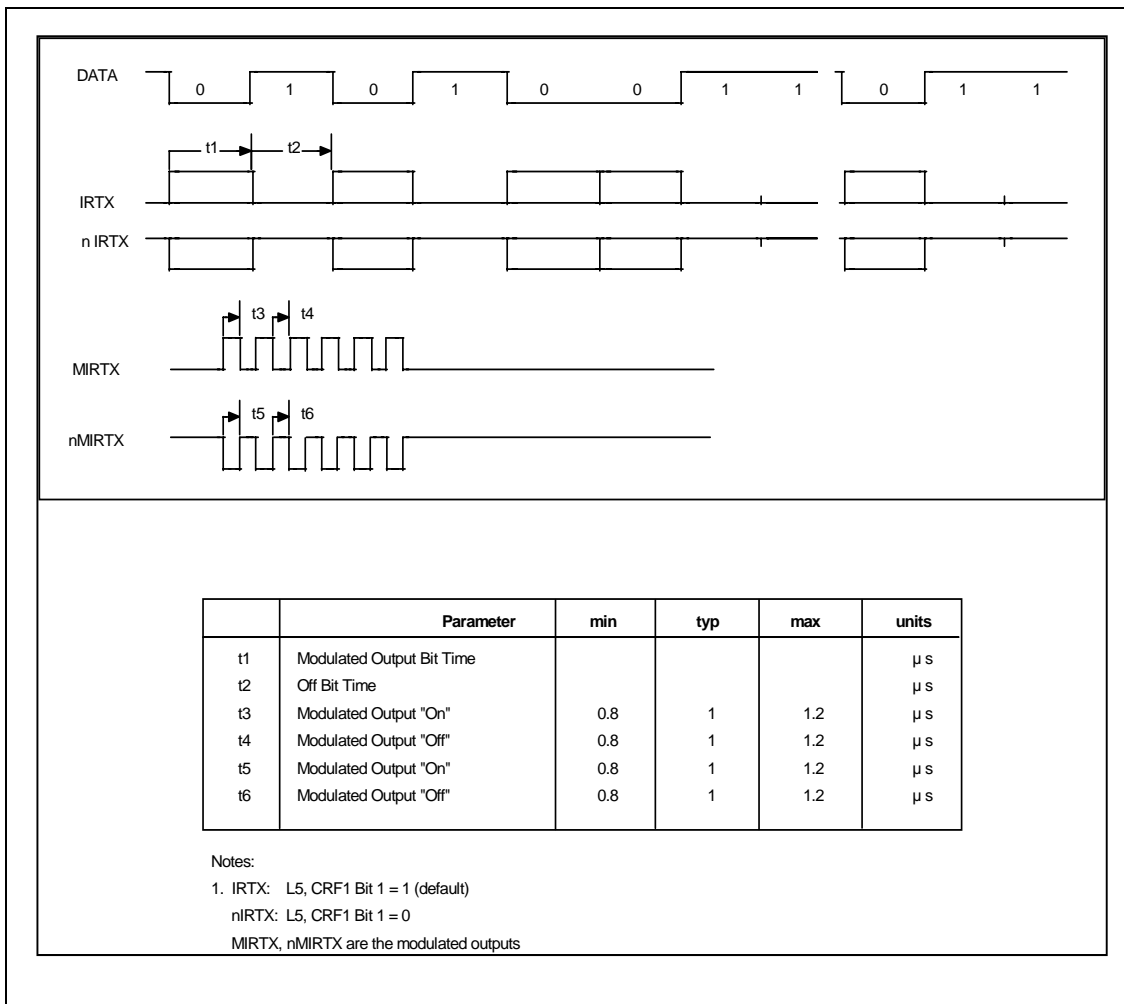

FIGURE 33 - ASK IR TRANSMIT TIMING

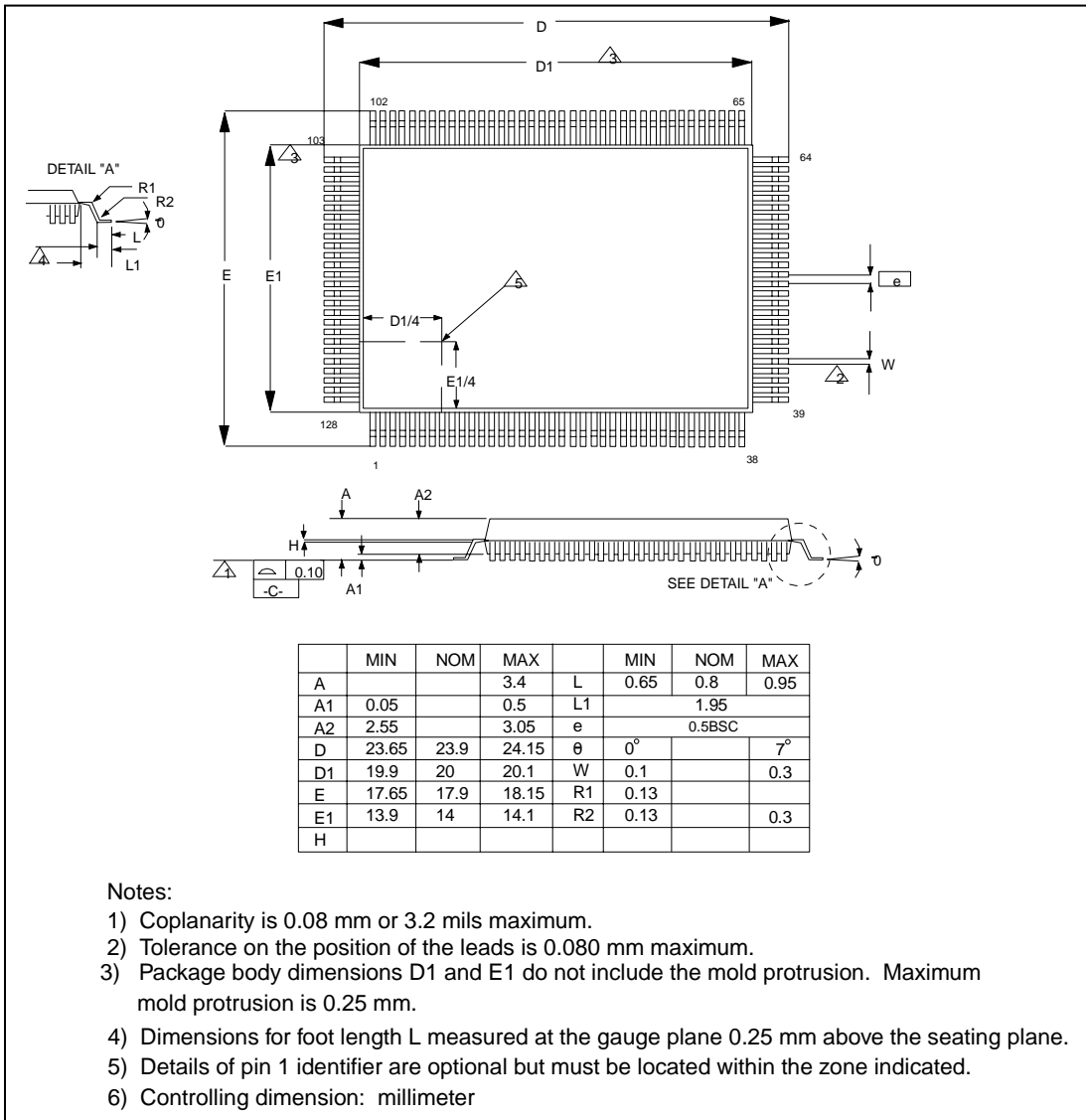

FIGURE 34 - 128 PIN QFP PACKAGE OUTLINE



80 ARKAY DRIVE, HAUPPAUGE, NY 11788 (631) 435-6000, FAX (631) 273-3123

Copyright © 2007 SMSC or its subsidiaries. All rights reserved.

Circuit diagrams and other information relating to SMSC products are included as a means of illustrating typical applications. Consequently, complete information sufficient for construction purposes is not necessarily given. Although the information has been checked and is believed to be accurate, no responsibility is assumed for inaccuracies. SMSC reserves the right to make changes to specifications and product descriptions at any time without notice. Contact your local SMSC sales office to obtain the latest specifications before placing your product order. The provision of this information does not convey to the purchaser of the described semiconductor devices any licenses under any patent rights or other intellectual property rights of SMSC or others. All sales are expressly conditional on your agreement to the terms and conditions of the most recently dated version of SMSC's standard Terms of Sale Agreement dated before the date of your order (the "Terms of Sale Agreement"). The product may contain design defects or errors known as anomalies which may cause the product's functions to deviate from published specifications. Anomaly sheets are available upon request. SMSC products are not designed, intended, authorized or warranted for use in any life support or other application where product failure could cause or contribute to personal injury or severe property damage. Any and all such uses without prior written approval of an Officer of SMSC and further testing and/or modification will be fully at the risk of the customer. Copies of this document or other SMSC literature, as well as the Terms of Sale Agreement, may be obtained by visiting SMSC's website at <http://www.smsc.com>. SMSC is a registered trademark of Standard Microsystems Corporation ("SMSC"). Product names and company names are the trademarks of their respective holders.

SMSC DISCLAIMS AND EXCLUDES ANY AND ALL WARRANTIES, INCLUDING WITHOUT LIMITATION ANY AND ALL IMPLIED WARRANTIES OF MERCHANTABILITY, FITNESS FOR A PARTICULAR PURPOSE, TITLE, AND AGAINST INFRINGEMENT AND THE LIKE, AND ANY AND ALL WARRANTIES ARISING FROM ANY COURSE OF DEALING OR USAGE OF TRADE. IN NO EVENT SHALL SMSC BE LIABLE FOR ANY DIRECT, INCIDENTAL, INDIRECT, SPECIAL, PUNITIVE, OR CONSEQUENTIAL DAMAGES; OR FOR LOST DATA, PROFITS, SAVINGS OR REVENUES OF ANY KIND; REGARDLESS OF THE FORM OF ACTION, WHETHER BASED ON CONTRACT; TORT; NEGLIGENCE OF SMSC OR OTHERS; STRICT LIABILITY; BREACH OF WARRANTY; OR OTHERWISE; WHETHER OR NOT ANY REMEDY OF BUYER IS HELD TO HAVE FAILED OF ITS ESSENTIAL PURPOSE, AND WHETHER OR NOT SMSC HAS BEEN ADVISED OF THE POSSIBILITY OF SUCH DAMAGES.

FDC37B78x Rev. 02-09-07

Данный компонент на территории Российской Федерации

Вы можете приобрести в компании MosChip.

Для оперативного оформления запроса Вам необходимо перейти по данной ссылке:

<http://moschip.ru/get-element>

Вы можете разместить у нас заказ для любого Вашего проекта, будь то серийное производство или разработка единичного прибора.

В нашем ассортименте представлены ведущие мировые производители активных и пассивных электронных компонентов.

Нашей специализацией является поставка электронной компонентной базы двойного назначения, продукции таких производителей как XILINX, Intel (ex.ALTERA), Vicor, Microchip, Texas Instruments, Analog Devices, Mini-Circuits, Amphenol, Glenair.

Сотрудничество с глобальными дистрибьюторами электронных компонентов, предоставляет возможность заказывать и получать с международных складов практически любой перечень компонентов в оптимальные для Вас сроки.

На всех этапах разработки и производства наши партнеры могут получить квалифицированную поддержку опытных инженеров.

Система менеджмента качества компании отвечает требованиям в соответствии с ГОСТ Р ИСО 9001, ГОСТ РВ 0015-002 и ЭС РД 009

Офис по работе с юридическими лицами:

105318, г.Москва, ул.Щербаковская д.3, офис 1107, 1118, ДЦ «Щербаковский»

Телефон: +7 495 668-12-70 (многоканальный)

Факс: +7 495 668-12-70 (доб.304)

E-mail: info@moschip.ru

Skype отдела продаж:

moschip.ru

moschip.ru_4

moschip.ru_6

moschip.ru_9