



050-344

DATA SHEET
FMC CONNECTIVITY CARD
FOR GLENAIR PCB MOUNT OPTO-ELECTRONIC CONVERTERS
TRANSCEIVERS, TRANSMITTERS AND RECEIVERS

REV	DESCRIPTION	DATE	APPROVED
A	Initial Release	3/14/2016	BD

14U2-7544

THIS COPYRIGHTED DOCUMENT IS THE PROPERTY OF GLENAIR, INC. AND IS FURNISHED ON THE CONDITION THAT IT IS NOT TO BE DISCLOSED, REPRODUCED IN WHOLE OR IN PART, OR USED TO SOLICIT QUOTATIONS FROM COMPETITIVE SOURCES, OR USED FOR MANUFACTURE BY ANYONE OTHER THAN GLENAIR, INC. WITHOUT WRITTEN PERMISSION FROM GLENAIR, INC. THE INFORMATION HEREIN HAS BEEN DEVELOPED AT GLENAIR'S EXPENSE AND MAY BE USED FOR ENGINEERING EVALUATION AND INCORPORATION INTO TECHNICAL SPECIFICATIONS AND OTHER DOCUMENTS WHICH SPECIFY PROCUREMENT OF PRODUCTS FROM GLENAIR, INC.

050-344

FMC CONNECTIVITY CARD

For Glenair PCB Mount Opto-Electronic Converters

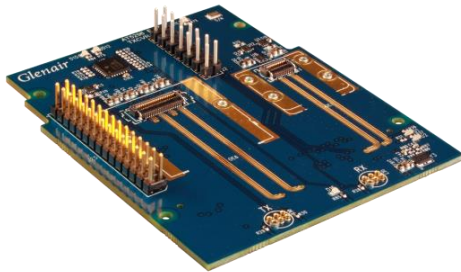

Glenair 050-344 FPGA Mezzanine Card (FMC) Connectivity Card provides a convenient method to easily incorporate a wide range of Glenair Harsh Environment PCB Mount Transceiver, Transmitter and Receiver products as well as Glenair size 8 Opto-electronic transmitter and receiver contacts into FPGA based systems. It is compatible with Xilinx® evaluation boards with FMC connector(s) board and uses the High Pin Count (HPC) version of the FMC connector.

This FMC card is offered in three configurations, see how to order information, to support all categories of Glenair PCB Mount devices. Electrical connections to PCB Mount Opto-electronic devices are through high speed Samtec connector mounted on the 050-344 card. The card has an FMC High Pin Count (HPC) connector to mate to the Host FPGA carrier board which interface with four high-speed serial transceivers on the FPGA carrier board. It is compatible with either HPC or Low Pin Count (LPC) connector (restricted to single high-speed serial transceiver for LPC) on the host board. The 050-344 card also incorporates LEDs for RX LOS indications as well as a low-jitter 156.25MHz oscillator for use as a clock source for the high-speed serial transceivers. The board also incorporates I²C current monitor IC and an I²C GPIO IC so each DUT can be monitored. 22 GPIO pins are also made available for the user.

KEY FEATURES/BENEFITS

- Industry standard, modular FPGA I/O in FMC (VITA 57.1) module
- Supports large variety of Opto-Electronic devices suitable for Harsh Environment (Wide temperature ranges and Extremely High Vibration)
 - 10 Mbps to 12.5 Gbps
- Direct connections between Glenair PCB Mount transceivers and host FPGA ensures maximum throughput and minimum latency
- HPC – High Pin Count FMC
 - Provides access to 4 high speed transceivers
 - Compatible with LPC Host board connectors as well but then restricted to single high-speed transceiver (DP0)

- Low-jitter 156.25 MHz Clock source available on-board
- SFF 8472 Digital Diagnostic Monitoring (DMI) can be accessed from host board via I²C or via connector Header
- I²C GPIO for current monitoring, RX_LOS, TX_FAULT, TX_DISABLE control and signaling

APPLICATIONS

- As an evaluation tool for Glenair Opto-electronic modules which are suited to Harsh Environment Applications such as: Airborne, Tactical Military, Oil and Gas, Railway and Shipboard
 - Ethernet, Fibre Channel, 1x, 2x, 4x, 8x, SFPDP, Aurora
 - Video (DVI, SMPTE, ARINC818, etc)

HOW TO ORDER

Part Number	Description of Products to be tested	Glenair Opto-Electronic Existing and Planned Products supported:
050-344-A	Transceivers,	050-315, 050-318, 050-321, 050-324, 050-327, 050-340, 050-341, 050-342, 050-343, 050-352, 050-354, 050-356, 050-357, 050-362, 050-361, 050-369
	Dual-Transceivers	050-333
	Size 8 TX & RX OE Contacts	050-301, 050-307
050-344-B	Dual-Transmitters	050-316, 050-319, 050-325, 050-331,
	Dual-Receivers	050-317, 050-320, 050-326, 050-332
050-344-C	Quad-Transmitters	050-336, 050-363, 050-374,
	Quad-Receivers	050-337, 050-364, 050-375

050-344

FMC CONNECTIVITY CARD

For Glenair PCB Mount Opto-Electronic Converters

**What is included with 050-344:**

- FMC Connectivity Card (050-344)
- 050-344 Datasheet

Opto-Electronic Devices and Test cables sold separately: Many options can be supported.

- Glenair PCB Mount devices Selection Guide
 - http://www.glenair.com/opto_electronic/b.htm
- Fiber Optic Test cables as required:
 - MMF & SMF test cables can be configured to support all Glenair Opto-electronic components
 - FA03216: http://www.glenair.com/opto_electronic/pdf/b/fa03216.pdf

FMC I/O PINOUT

FMC HPC SAMTEC P/N:(ASP-134488-01)

	A	B	C	D	E	F	G	H	I	J
1	GND	RES1	GND	PG_C2M	GND	NC	GND	NC	GND	NC
2	DP1_M2C_P	GND	DP0_C2M_P	GND	NC	GND	NC	NC	NC	GND
3	DP1_M2C_N	GND	DP0_C2M_N	GND	NC	GND	NC	GND	NC	GND
4	GND	NC	GND	GBTCLK0_M2C_P	GND	NC	GND	NC	NC	NC
5	GND	NC	GND	GBTCLK0_M2C_N	GND	NC	GND	NC	GND	NC
6	DP2_M2C_P	GND	DP0_M2C_P	GND	NC	GND	LA00_P_CC	GND	NC	GND
7	DP2_M2C_N	GND	DP0_M2C_N	GND	NC	NC	LA00_N_CC	LA02_P	NC	NC
8	GND	NC	GND	SCL1	GND	NC	GND	LA02_N	GND	NC
9	GND	NC	GND	SDA1	NC	GND	LA03_P	GND	NC	GND
10	DP3_M2C_P	GND	LA06_P	GND	NC	NC	LA03_N	LA04_P	NC	NC
11	DP3_M2C_N	GND	LA06_N	LA05_P	GND	NC	GND	LA04_N	GND	NC
12	GND	NC	GND	LA05_N	NC	GND	LA08_P	GND	NC	GND
13	GND	NC	GND	GND	NC	NC	LA08_N	LA07_P	NC	NC
14	NC	GND	LA10_P	LA09_P	GND	NC	GND	LA07_N	GND	NC
15	NC	GND	LA10_N	LA09_N	NC	GND	SDA2	GND	NC	GND
16	GND	NC	GND	GND	NC	NC	SCL2	LA11_P	NC	NC
17	GND	NC	GND	NC	GND	NC	GND	LA11_N	GND	NC
18	NC	GND	NC	NC	NC	GND	NC	GND	NC	GND
19	NC	GND	NC	GND	NC	NC	NC	NC	NC	NC
20	GND	NC	GND	NC	GND	NC	GND	NC	GND	NC
21	GND	NC	GND	NC	NC	GND	NC	GND	NC	GND
22	DP1_C2M_P	GND	NC	GND	NC	NC	NC	NC	NC	NC
23	DP1_C2M_N	GND	NC	NC	GND	NC	GND	NC	GND	NC
24	GND	NC	GND	NC	NC	GND	NC	GND	NC	GND
25	GND	NC	GND	GND	NC	NC	NC	NC	NC	NC
26	DP2_C2M_P	GND	NC	NC	GND	NC	GND	NC	GND	NC
27	DP2_C2M_N	GND	NC	NC	NC	GND	NC	GND	NC	GND
28	GND	NC	GND	GND	NC	NC	NC	NC	NC	NC
29	GND	NC	GND	NC	GND	NC	GND	NC	GND	NC
30	DP3_C2M_P	GND	NC	TDI/TDO_LOOP	NC	GND	NC	GND	NC	GND
31	DP3_C2M_N	GND	NC	TDO/TDI_LOOP	NC	NC	NC	NC	NC	NC
32	GND	NC	GND	NC	GND	NC	GND	NC	GND	NC
33	GND	NC	GND	NC	NC	GND	NC	GND	NC	GND
34	NC	GND	NC	NC	NC	NC	NC	NC	NC	NC
35	NC	GND	NC	NC	GND	NC	GND	NC	GND	NC
36	GND	NC	GND	3P3V	NC	GND	NC	GND	NC	GND
37	GND	NC	NC	GND	NC	NC	NC	NC	NC	NC
38	NC	GND	GND	3P3V	GND	NC	GND	NC	GND	NC
39	NC	GND	3P3V	GND	VADJ	GND	NC	GND	NC	GND
40	GND	NC	GND	3P3V	GND	NC	GND	NC	GND	NC

050-344

FMC CONNECTIVITY CARD

For Glenair PCB Mount Opto-Electronic Converters



Functional Block Diagram (050-344-A)

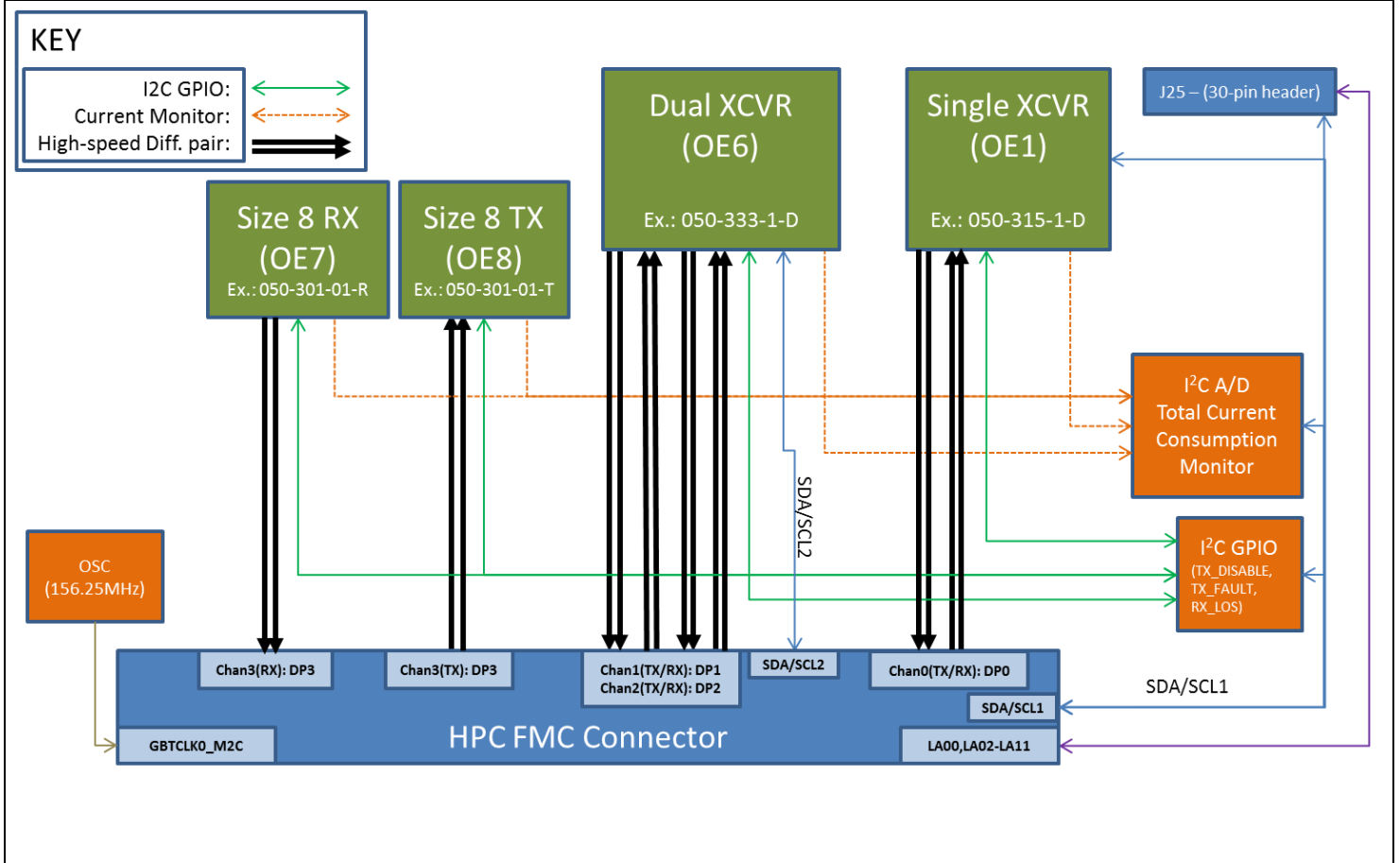

050-344

FMC CONNECTIVITY CARD

For Glenair PCB Mount Opto-Electronic Converters



Pictorial Block Diagram (050-344-A)

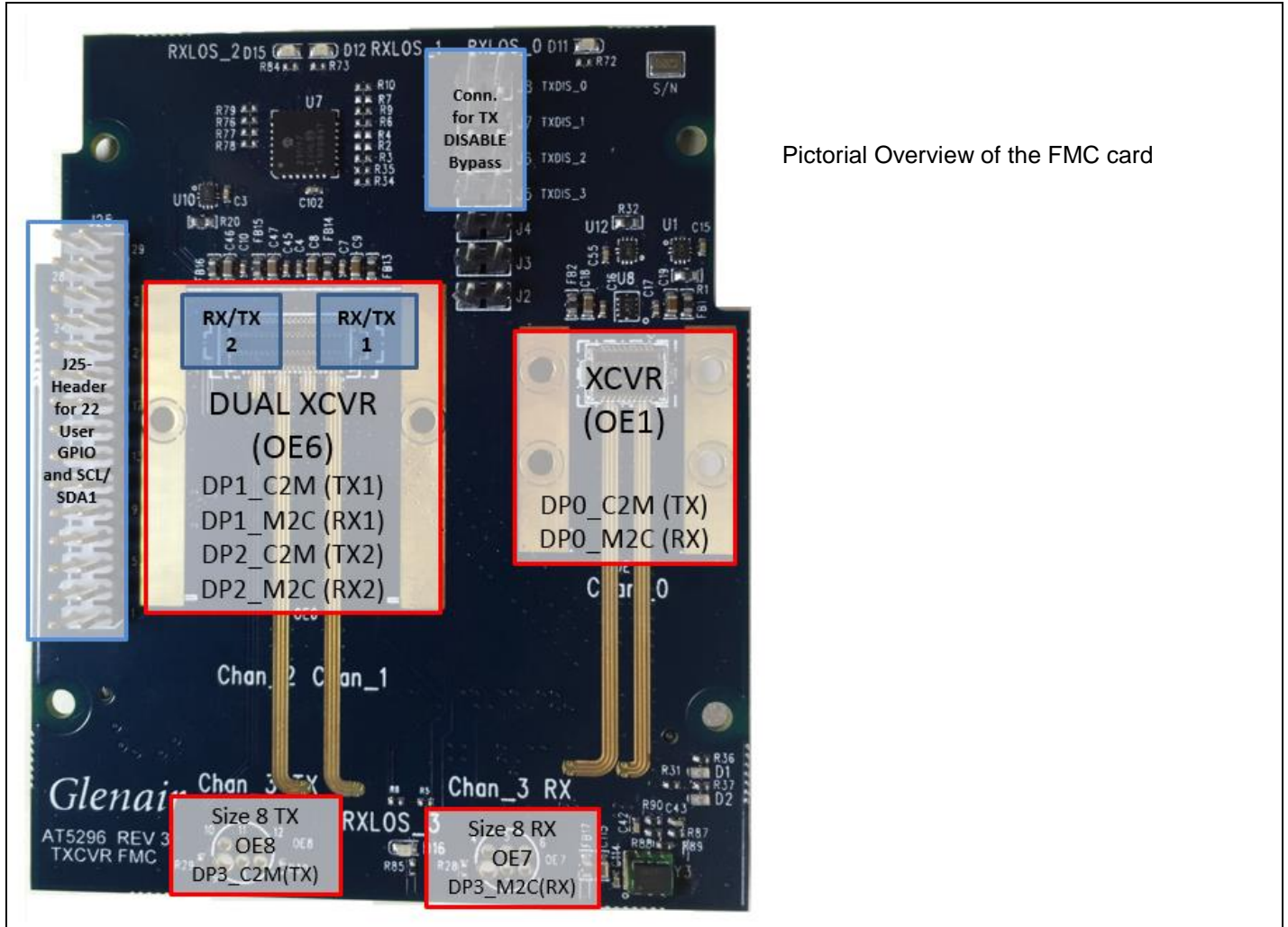

050-344

FMC CONNECTIVITY CARD

For Glenair PCB Mount Opto-Electronic Converters



Schematic User interface Blocks (050-344-A)

J25 Header pinout

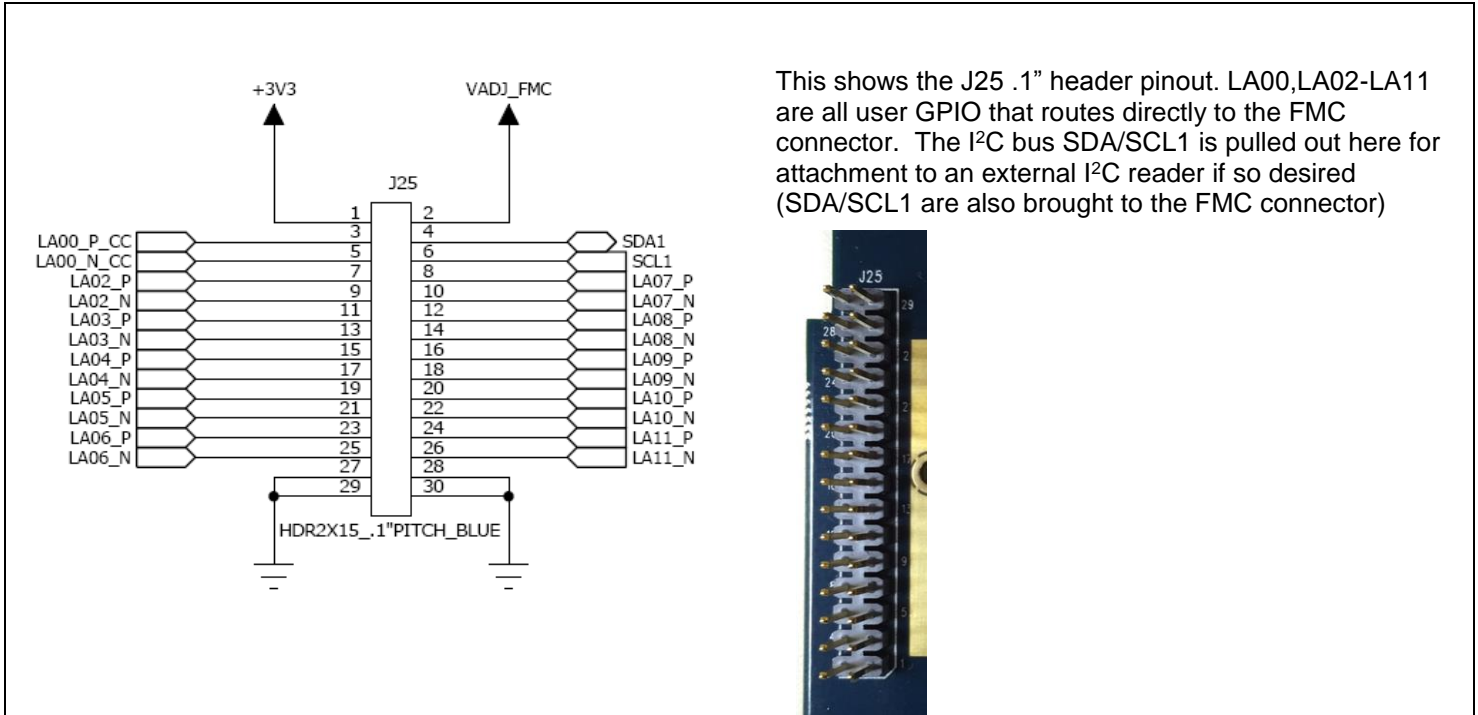

U8 Current Monitor (I²C A/D)

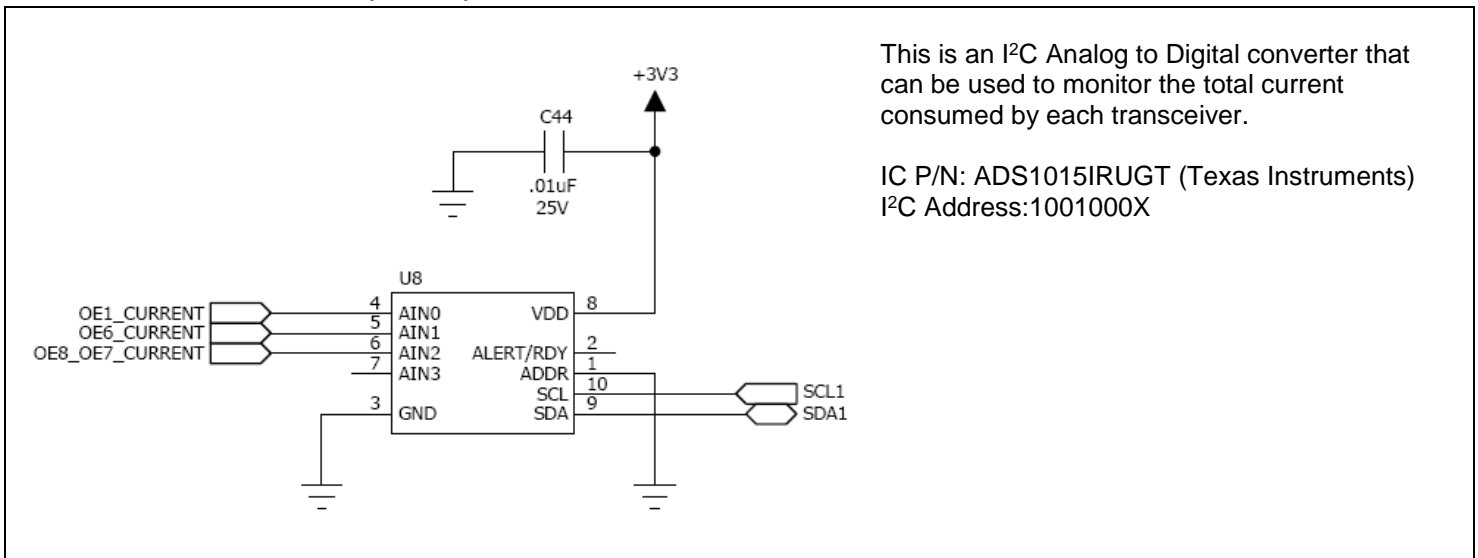

050-344

FMC CONNECTIVITY CARD

For Glenair PCB Mount Opto-Electronic Converters



Schematic User interface Blocks (050-344-A) continued

U7 I²C GPIO

This is an I2C controlled GPIO device that can be used to read the RX_LOS signal and TX_FAULT status of each transceiver as well as set the TX_DISABLE lines to disable the transmitter output. If control of this is not desired the user can use a jumper on the J5, J6, J7 and J8 headers to manually enable the transmitter output. The headers are also marked on the board as TXDIS_0 for channel 0 (single XCVR) TXDIS_1 for channel 1 (Dual XCVR first chan.) and so on.

IC P/N: MCP23017-E/ML (Microchip)
I2C address: 0100000X

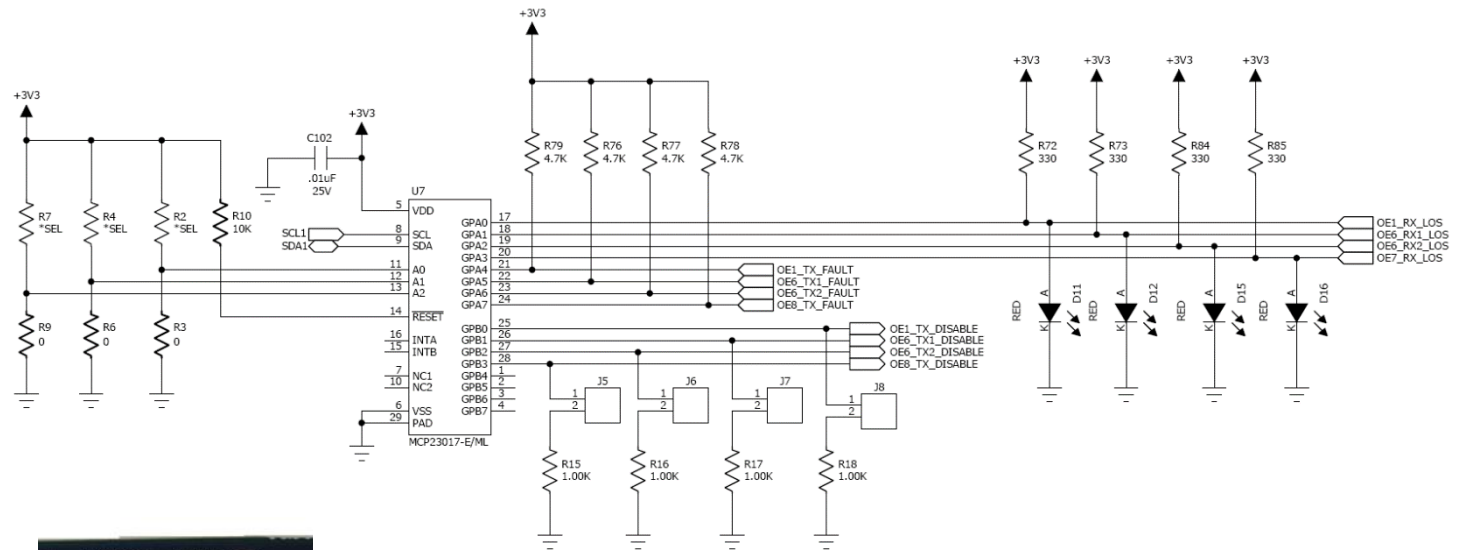

←Headers to manually enable the transmitters

050-344

FMC CONNECTIVITY CARD

For Glenair PCB Mount Opto-Electronic Converters



Functional Block Diagram (050-344-B)

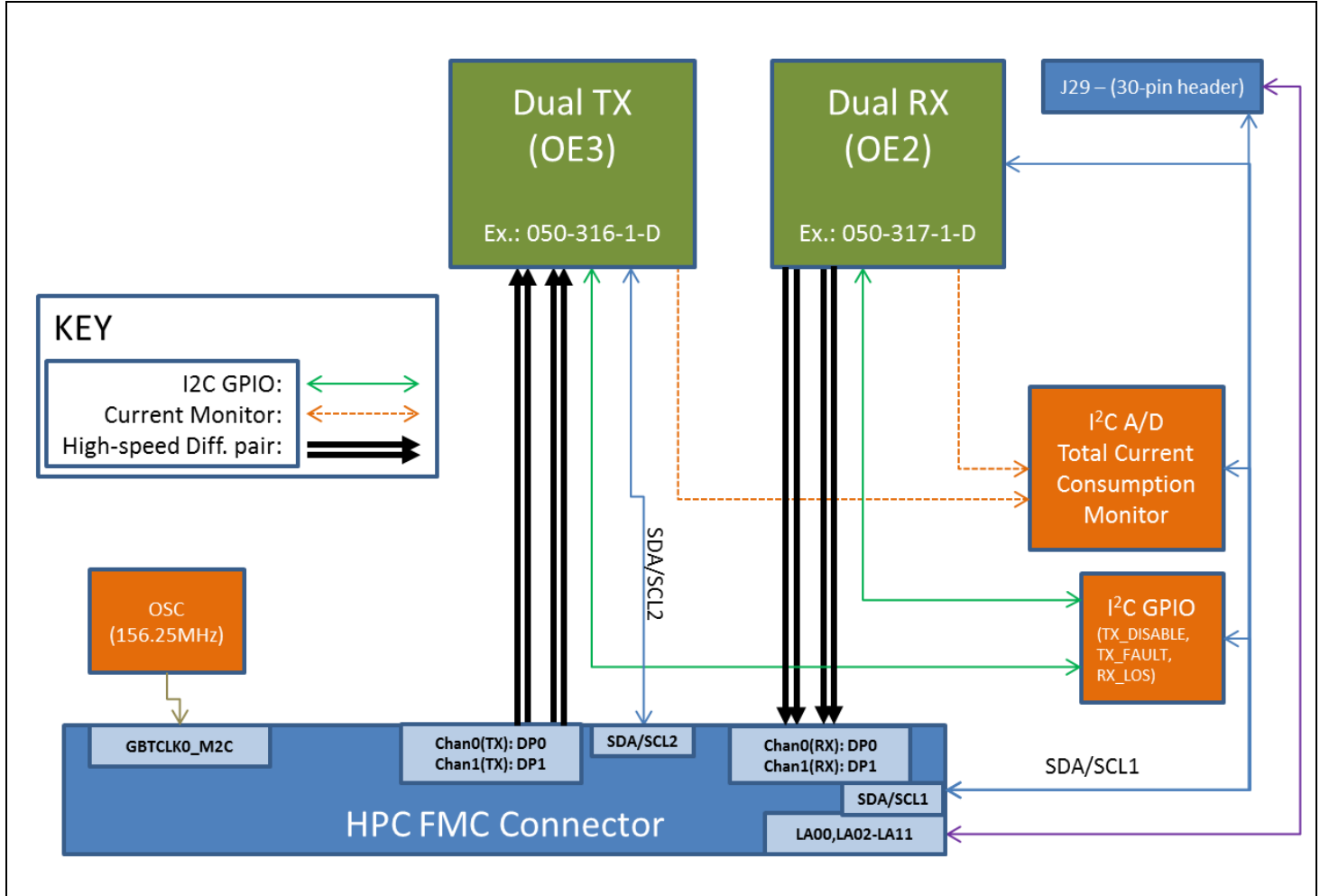

050-344

FMC CONNECTIVITY CARD

For Glenair PCB Mount Opto-Electronic Converters



Pictorial Block Diagram (050-344-B)

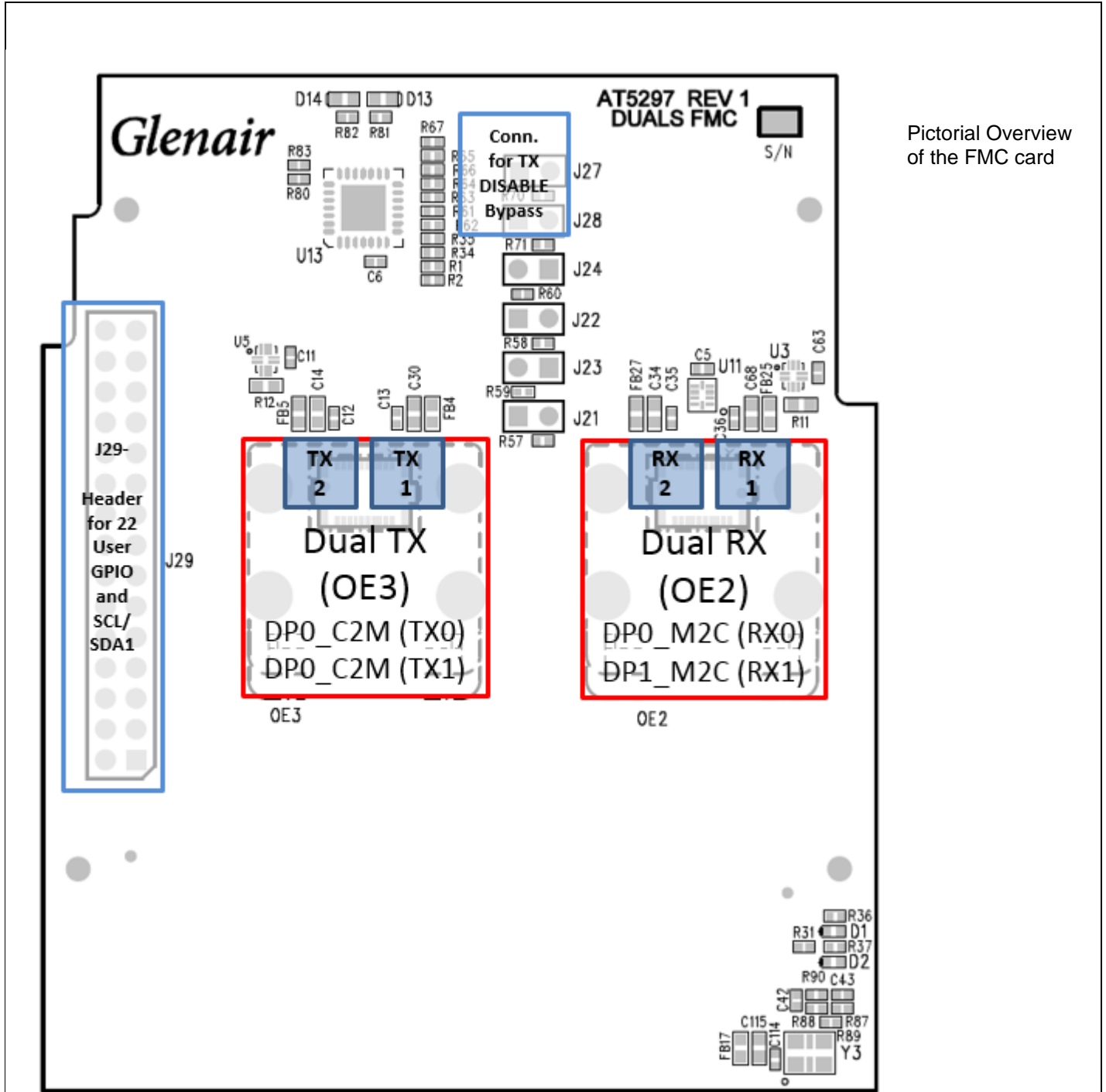

Pictorial Overview of the FMC card

050-344

FMC CONNECTIVITY CARD

For Glenair PCB Mount Opto-Electronic Converters



Schematic User interface Blocks (050-344-B)

J29 Header pinout

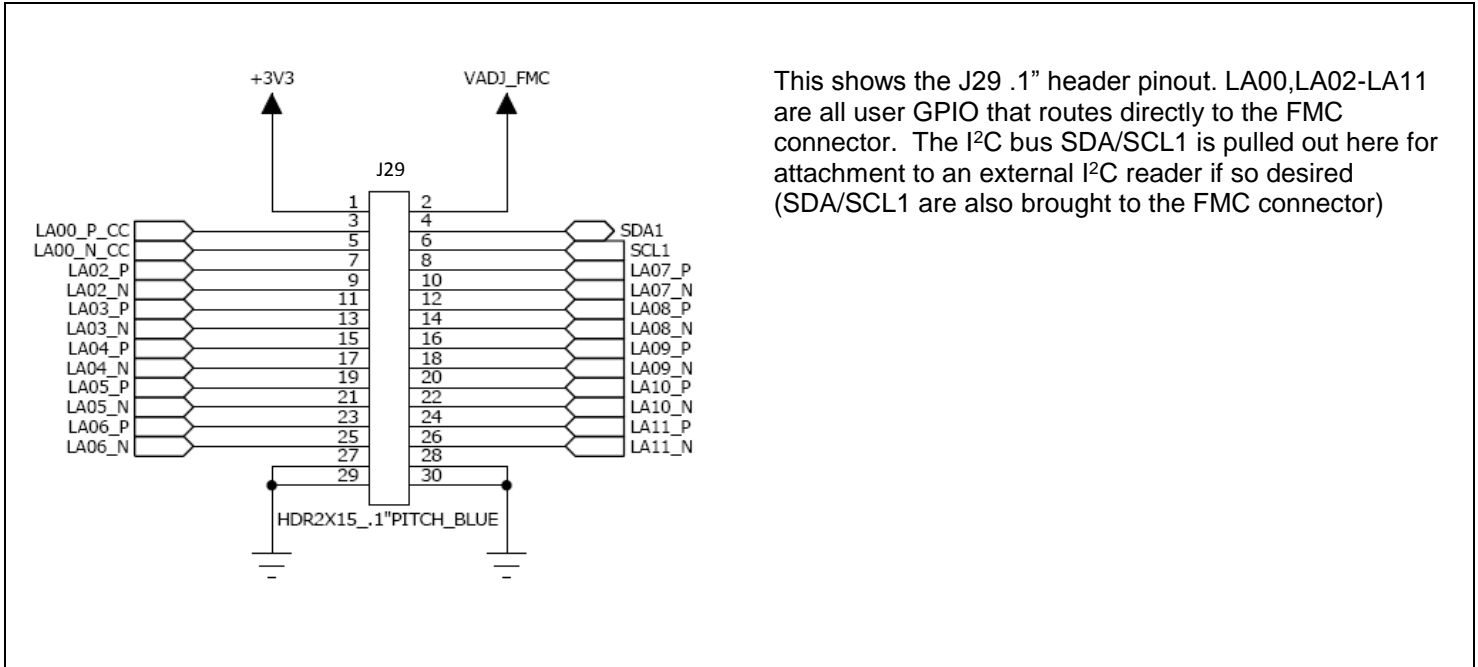

U11 Current Monitor (I²C A/D)

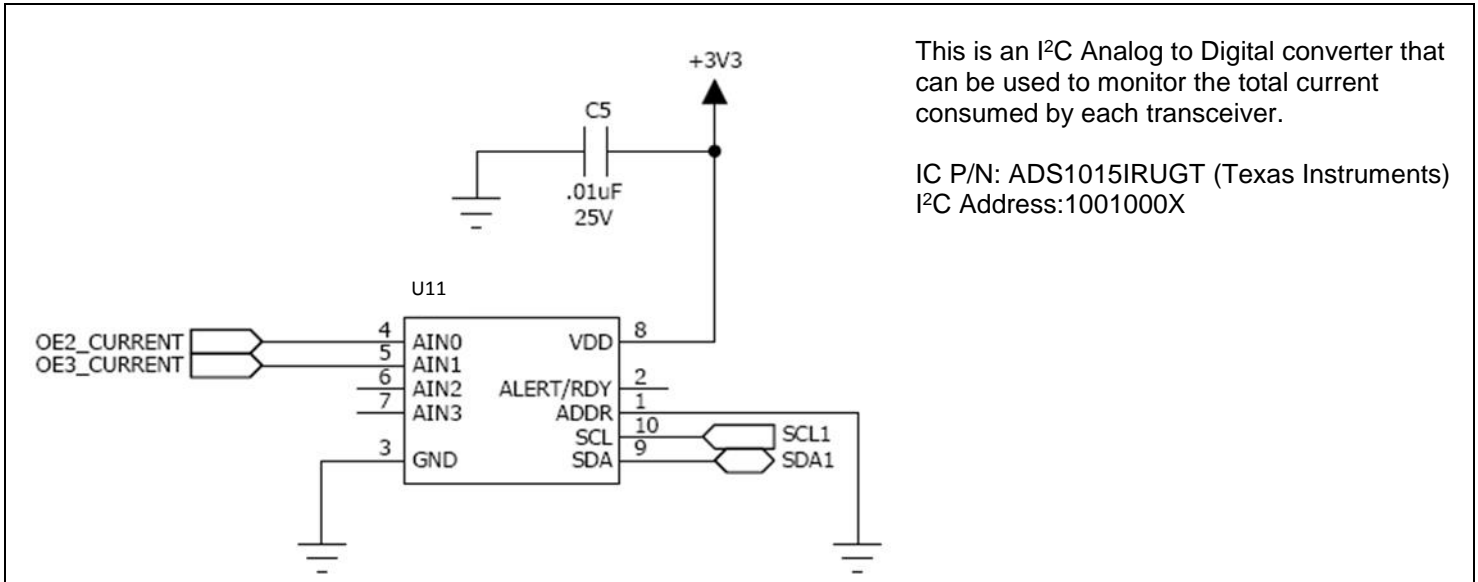

050-344

FMC CONNECTIVITY CARD

For Glenair PCB Mount Opto-Electronic Converters



Schematic User interface Blocks (050-344-B) continued

U13 I²C GPIO

This is an I2C controlled GPIO device that can be used to read the RX_LOS signal and TX_FAULT status of each transceiver as well as set the TX_DISABLE lines to disable the transmitter output. If control of this is not desired the user can use a jumper on the J27 and J28 headers to manually enable the transmitter output. The headers are also marked on the board as TXDIS_0 for channel 0 (single XCVR) TXDIS_1 for channel 1(Dual XCVR first chan.) and so on.

IC P/N: MCP23017-E/ML (Microchip)
I2C address: 0100000X

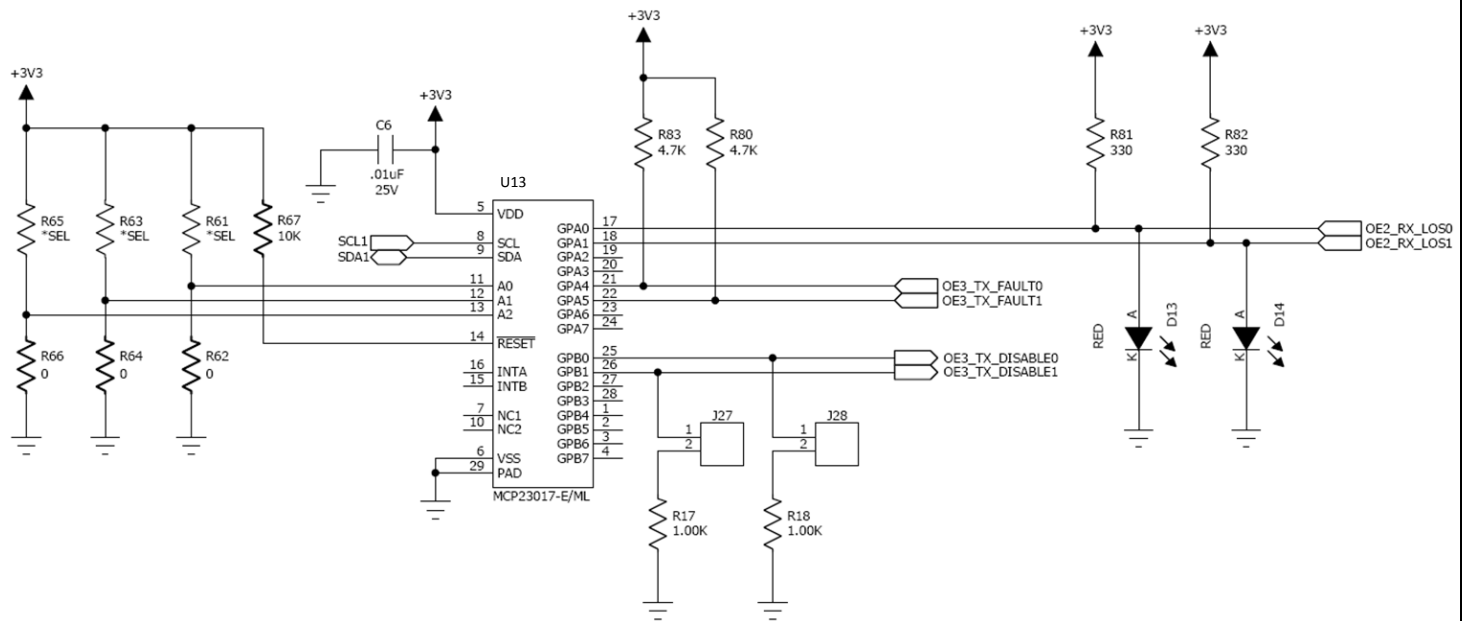

050-344

FMC CONNECTIVITY CARD

For Glenair PCB Mount Opto-Electronic Converters



Functional Block Diagram (050-344-C)

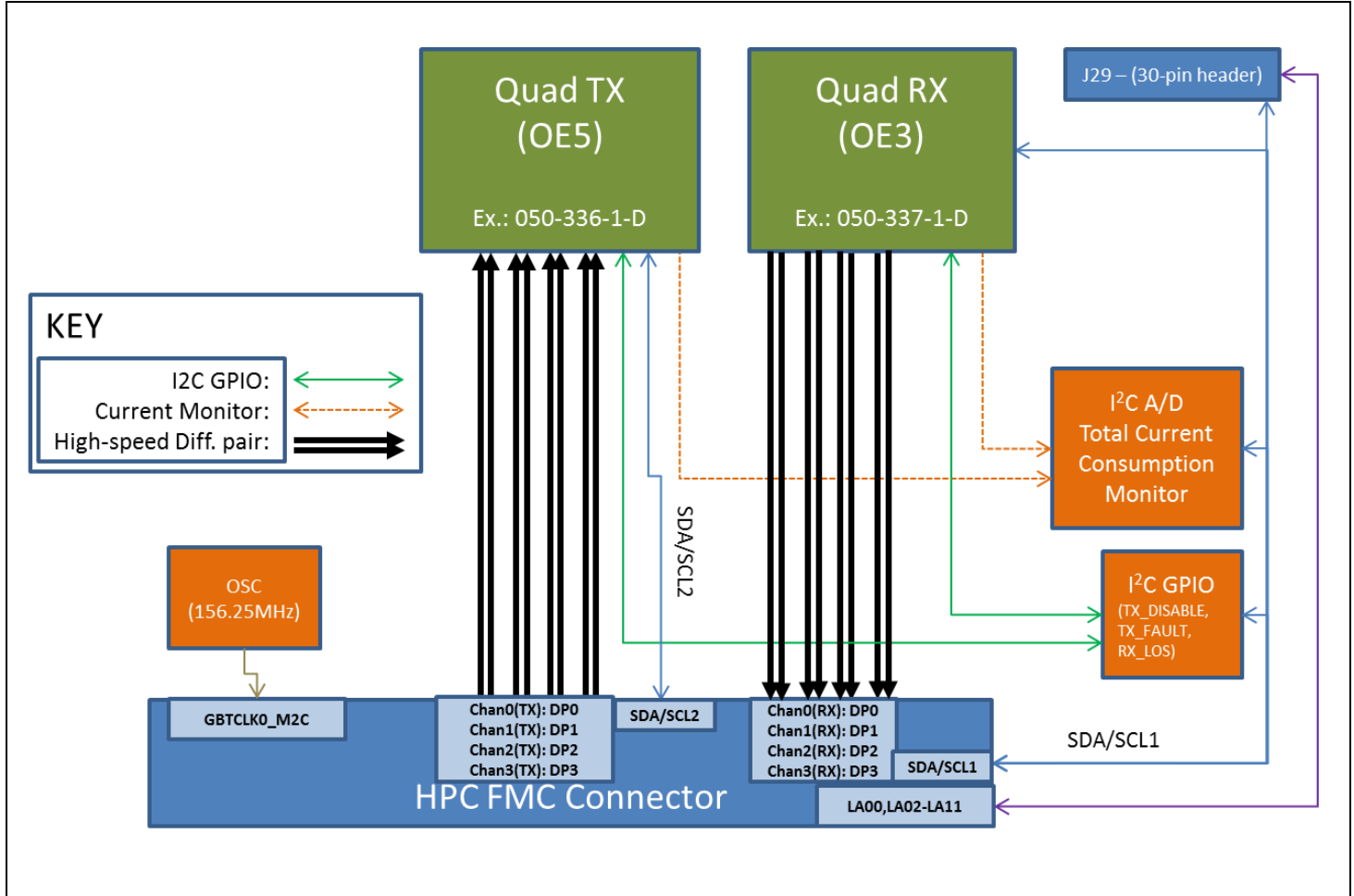

050-344

FMC CONNECTIVITY CARD

For Glenair PCB Mount Opto-Electronic Converters



Pictorial Block Diagram (050-344-C)

Pictorial Overview of the FMC card

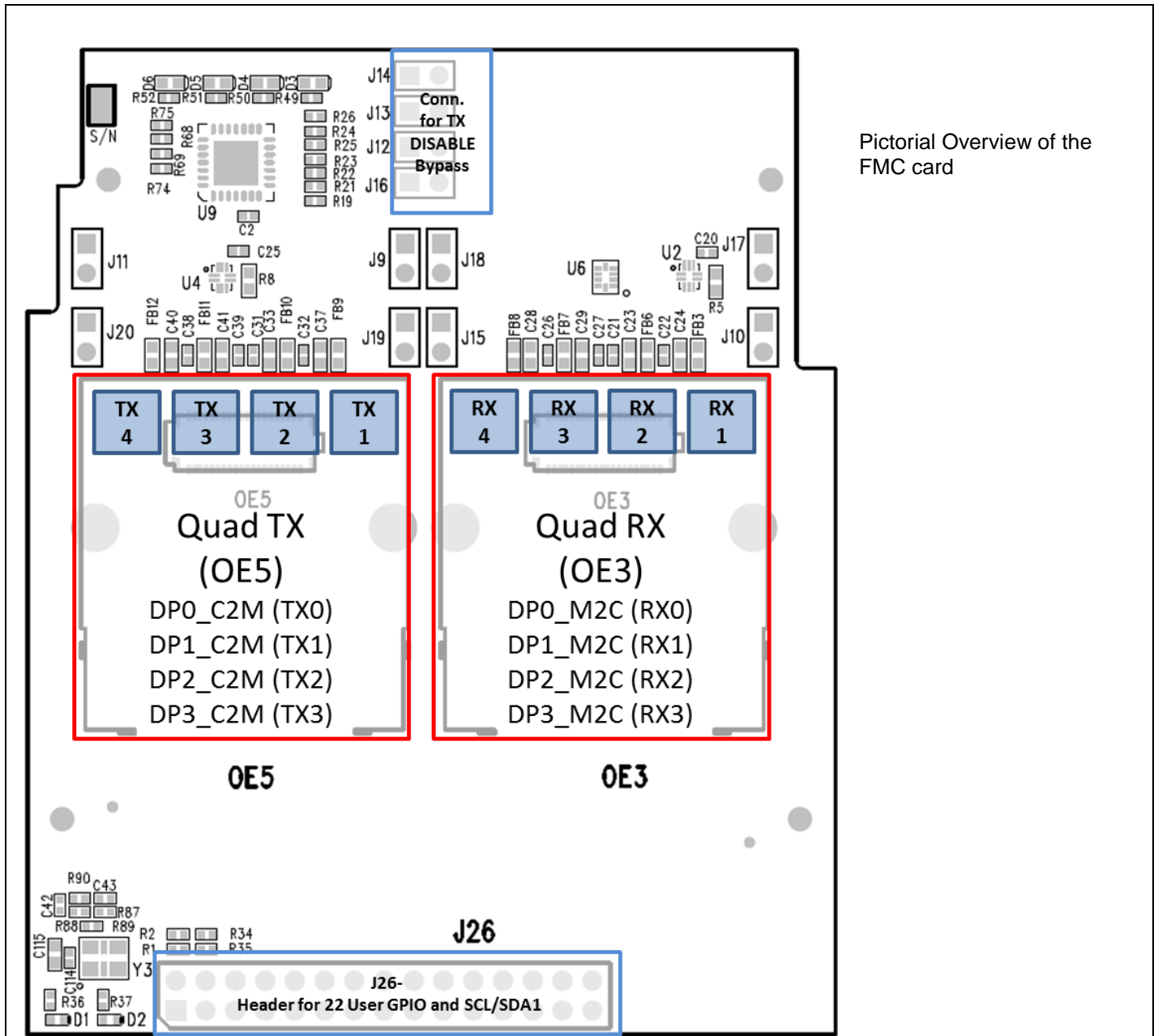

050-344

FMC CONNECTIVITY CARD

For Glenair PCB Mount Opto-Electronic Converters



Schematic User interface Blocks (050-344-C)

J26 Header pinout

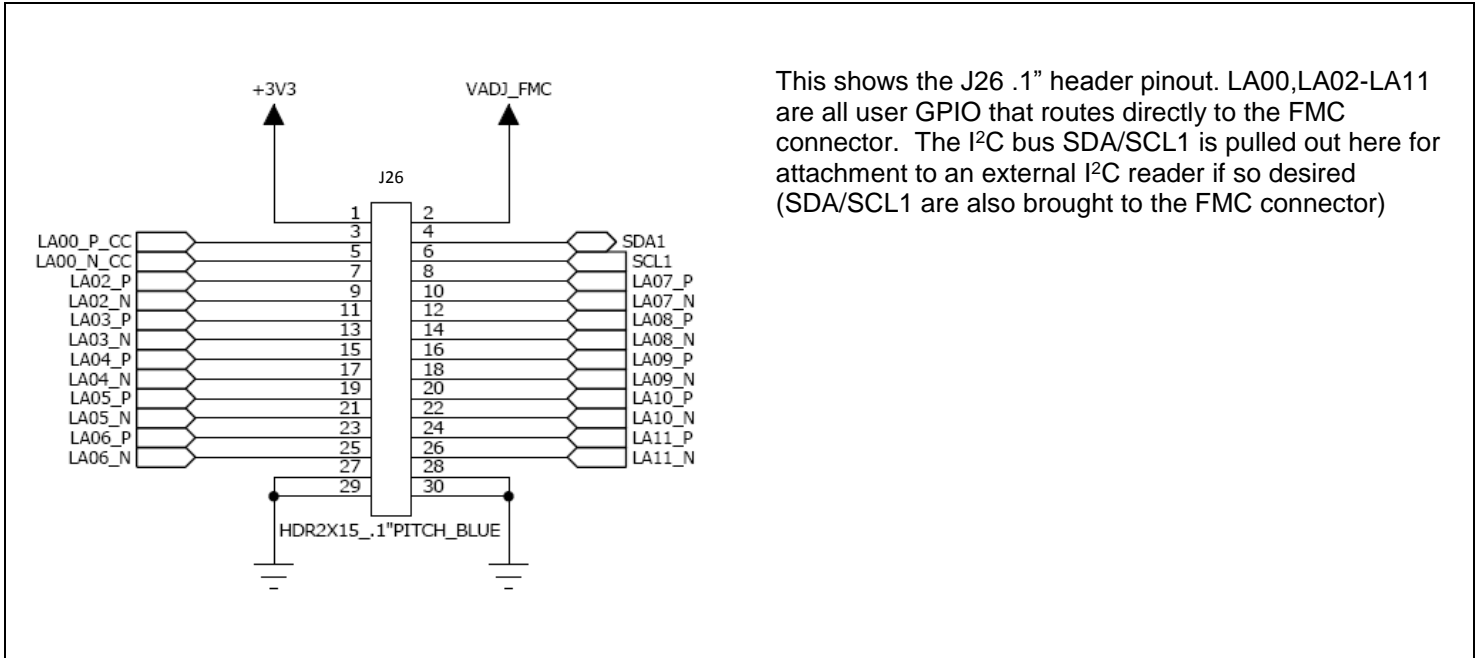

U6 Current Monitor (I²C A/D)

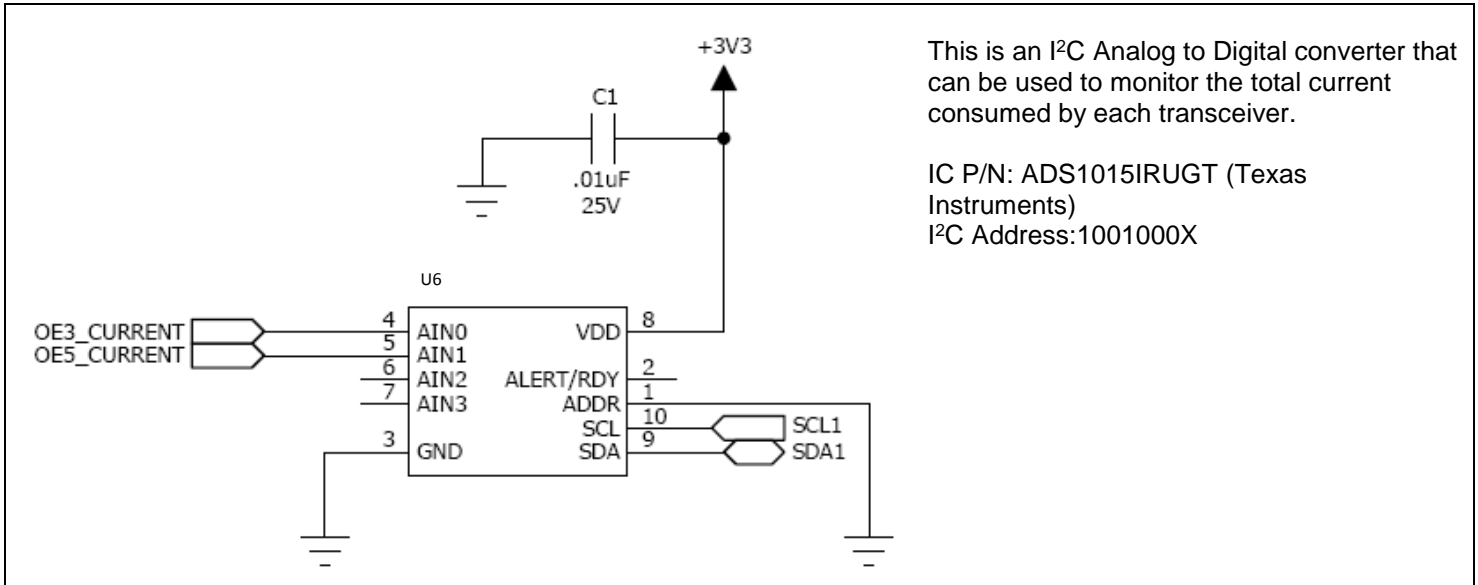

050-344

FMC CONNECTIVITY CARD

For Glenair PCB Mount Opto-Electronic Converters



Schematic User interface Blocks (050-344-C) continued

U9 I²C GPIO

This is an I2C controlled GPIO device that can be used to read the RX_LOS signal and TX_FAULT status of each transceiver as well as set the TX_DISABLE lines to disable the transmitter output. If control of this is not desired the user can use a jumper on the J16, J12, J13 or J14 headers to manually enable the transmitter output.

IC P/N: MCP23017-E/ML (Microchip)
I2C address: 0100000X

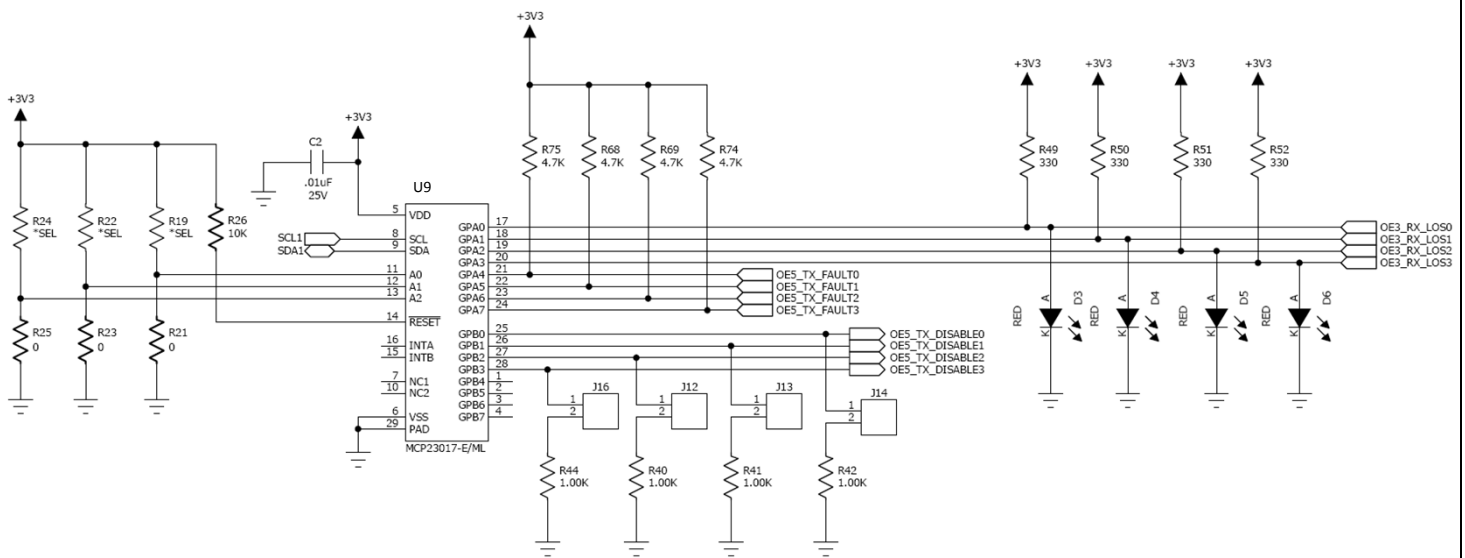

050-344

FMC CONNECTIVITY CARD

For Glenair PCB Mount Opto-Electronic Converters



Supported Media

Glenair Fiber Optic Transceivers, Transmitters, Receivers from 100Mbps to 10Gbps

FPGA Interface

- FMC High Pin Count (HPC) connector
 - Four (4) high-speed serial FMC links DP0 – DP3 differential pairs
 - 22 GPIO for user signals (LA00,LA02-LA11)
 - Two (2) I²C buses for transceiver status and control
 - I²C A/D to read transceiver current
 - I²C GPIO to control TX_DISABLE and read TX_FAULT and RX_LOS status
 - Jumpers to bypass TX_DISABLE signals
 - LED indication for Loss of Signal (RX_LOS)

Reference clock

- 156.25 MHz LVPECL differential Clock Oscillator input on GBTCLK0 pins [ABRACON (ASEMPLP-156.250MHZ-LR-T)]

Host boards:

- Spartan-6 Xilinx EK-S6-SP605
- Virtex-6 Xilinx EK-V6-ML605
- Kintex-7 Xilinx EK-K7-KC705
- Virtex-7 Xilinx EK-V7-VC707
- Zynq-7000 Avnet AES-MINI-ITX-7Z045

Данный компонент на территории Российской Федерации

Вы можете приобрести в компании MosChip.

Для оперативного оформления запроса Вам необходимо перейти по данной ссылке:

<http://moschip.ru/get-element>

Вы можете разместить у нас заказ для любого Вашего проекта, будь то серийное производство или разработка единичного прибора.

В нашем ассортименте представлены ведущие мировые производители активных и пассивных электронных компонентов.

Нашей специализацией является поставка электронной компонентной базы двойного назначения, продукции таких производителей как XILINX, Intel (ex.ALTERA), Vicor, Microchip, Texas Instruments, Analog Devices, Mini-Circuits, Amphenol, Glenair.

Сотрудничество с глобальными дистрибьюторами электронных компонентов, предоставляет возможность заказывать и получать с международных складов практически любой перечень компонентов в оптимальные для Вас сроки.

На всех этапах разработки и производства наши партнеры могут получить квалифицированную поддержку опытных инженеров.

Система менеджмента качества компании отвечает требованиям в соответствии с ГОСТ Р ИСО 9001, ГОСТ РВ 0015-002 и ЭС РД 009

Офис по работе с юридическими лицами:

105318, г.Москва, ул.Щербаковская д.3, офис 1107, 1118, ДЦ «Щербаковский»

Телефон: +7 495 668-12-70 (многоканальный)

Факс: +7 495 668-12-70 (доб.304)

E-mail: info@moschip.ru

Skype отдела продаж:

moschip.ru

moschip.ru_4

moschip.ru_6

moschip.ru_9