

**HIGH-SPEED SWITCHES**

**DESCRIPTION**

The 2N2218, 2N2219, 2N2221 and 2N2222 are silicon planar epitaxial NPN transistors in Jedec TO-39 (for 2N2218 and 2N2219) and in Jedec TO-18 (for 2N2221 and 2N2222) metal cases. They are designed for high-speed switching applications at collector currents up to 500 mA, and feature useful current gain over a wide range of collector current, low leakage currents and low saturation voltages.

 2N2218/2N2219 approved to CECC 50002-100, 2N2221/2N2222 approved to CECC 50002-101 available on request.

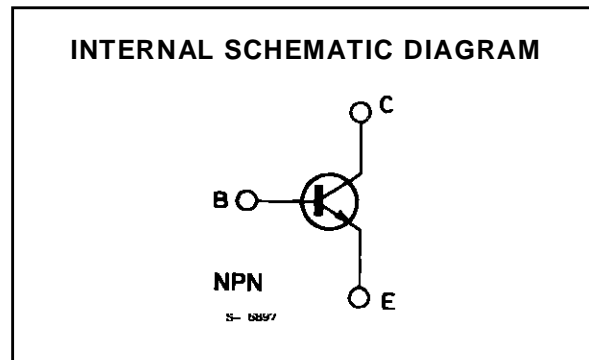
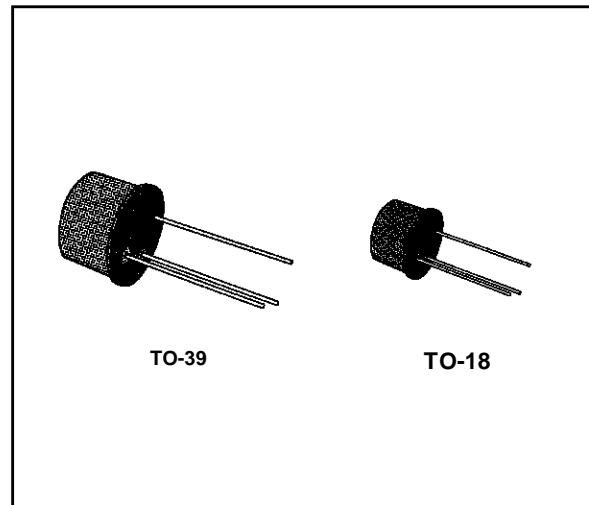

**ABSOLUTE MAXIMUM RATINGS**

Symbol	Parameter	Value	Unit
$V_{CBO}$	Collector-base Voltage ( $I_E = 0$ )	60	V
$V_{CEO}$	Collector-emitter Voltage ( $I_B = 0$ )	30	V
$V_{EBO}$	Emitter-base Voltage ( $I_C = 0$ )	5	V
$I_C$	Collector Current	0.8	A
$P_{tot}$	Total Power Dissipation at $T_{amb} \leq 25\text{ }^\circ\text{C}$ for <b>2N2218</b> and <b>2N2219</b> for <b>2N2221</b> and <b>2N2222</b> at $T_{case} \leq 25\text{ }^\circ\text{C}$ for <b>2N2218</b> and <b>2N2219</b> for <b>2N2221</b> and <b>2N2222</b>	0.8	W
		0.5	W
		3	W
		1.8	W
$T_{stg}$	Storage Temperature	- 65 to 200	$^\circ\text{C}$
$T_j$	Junction Temperature	175	$^\circ\text{C}$

## 2N2218-2N2219-2N2221-2N2222

### THERMAL DATA

			2N2218 2N2219	2N2221 2N2222
R <sub>th j-case</sub>	Thermal Resistance Junction-case	Max	50 °C/W	83.3 °C/W
R <sub>th j-amb</sub>	Thermal Resistance Junction-ambient	Max	187.5 °C/W	300 °C/W

### ELECTRICAL CHARACTERISTICS (T<sub>amb</sub> = 25 °C unless otherwise specified)

Symbol	Parameter	Test Conditions	Min.	Typ.	Max.	Unit
I <sub>CBO</sub>	Collector Cutoff Current (I <sub>E</sub> = 0)	V <sub>CB</sub> = 50 V V <sub>CB</sub> = 50 V    T <sub>amb</sub> = 150 °C			10 10	nA μA
I <sub>EBO</sub>	Emitter Cutoff Current (I <sub>C</sub> = 0)	V <sub>EB</sub> = 3 V			10	nA
V <sub>(BR) CBO</sub>	Collector-base Breakdown Voltage (I <sub>E</sub> = 0)	I <sub>C</sub> = 10 μA	60			V
V <sub>(BR) CEO</sub> *	Collector-emitter Breakdown Voltage (I <sub>B</sub> = 0)	I <sub>C</sub> = 10 mA	30			V
V <sub>(BR) EBO</sub>	Emitter-base Breakdown Voltage (I <sub>C</sub> = 0)	I <sub>E</sub> = 10 μA	5			V
V <sub>CE (sat)</sub> *	Collector-emitter Saturation Voltage	I <sub>C</sub> = 150 mA    I <sub>B</sub> = 15 mA I <sub>C</sub> = 500 mA    I <sub>B</sub> = 50 mA			0.4 1.6	V V
V <sub>BE (sat)</sub> *	Base-emitter Saturation Voltage	I <sub>C</sub> = 150 mA    I <sub>B</sub> = 15 mA I <sub>C</sub> = 500 mA    I <sub>B</sub> = 50 mA			1.3 2.6	V V
h <sub>FE</sub> *	DC Current Gain	for <b>2N2218</b> and <b>2N2221</b> I <sub>C</sub> = 0.1 mA    V <sub>CE</sub> = 10 V I <sub>C</sub> = 1 mA       V <sub>CE</sub> = 10 V I <sub>C</sub> = 10 mA      V <sub>CE</sub> = 10 V I <sub>C</sub> = 150 mA     V <sub>CE</sub> = 10 V I <sub>C</sub> = 500 mA     V <sub>CE</sub> = 10 V I <sub>C</sub> = 150 mA     V <sub>CE</sub> = 1 V for <b>2N2219</b> and <b>2N2222</b> I <sub>C</sub> = 0.1 mA    V <sub>CE</sub> = 10 V I <sub>C</sub> = 1 mA       V <sub>CE</sub> = 10 V I <sub>C</sub> = 10 mA      V <sub>CE</sub> = 10 V I <sub>C</sub> = 150 mA     V <sub>CE</sub> = 10 V I <sub>C</sub> = 500 mA     V <sub>CE</sub> = 10 V I <sub>C</sub> = 150 mA     V <sub>CE</sub> = 1 V	20 25 35 40 20 20		120	
f <sub>T</sub>	Transition Frequency	I <sub>C</sub> = 20 mA    V <sub>CE</sub> = 20 V f = 100 MHz	250			MHz
C <sub>CBO</sub>	Collector-base Capacitance	I <sub>E</sub> = 0 f = 100 kHz    V <sub>CB</sub> = 10 V			8	pF
R <sub>e(hie)</sub>	Real Part of Input Impedance	I <sub>C</sub> = 20 mA    V <sub>CE</sub> = 20 V f = 300 MHz			60	Ω

\* Pulsed : pulse duration = 300 μs, duty cycle = 1 %.

**TO-18 MECHANICAL DATA**

DIM.	mm			inch		
	MIN.	TYP.	MAX.	MIN.	TYP.	MAX.
A		12.7			0.500	
B			0.49			0.019
D			5.3			0.208
E			4.9			0.193
F			5.8			0.228
G	2.54			0.100		
H			1.2			0.047
I			1.16			0.045
L	45°			45°		

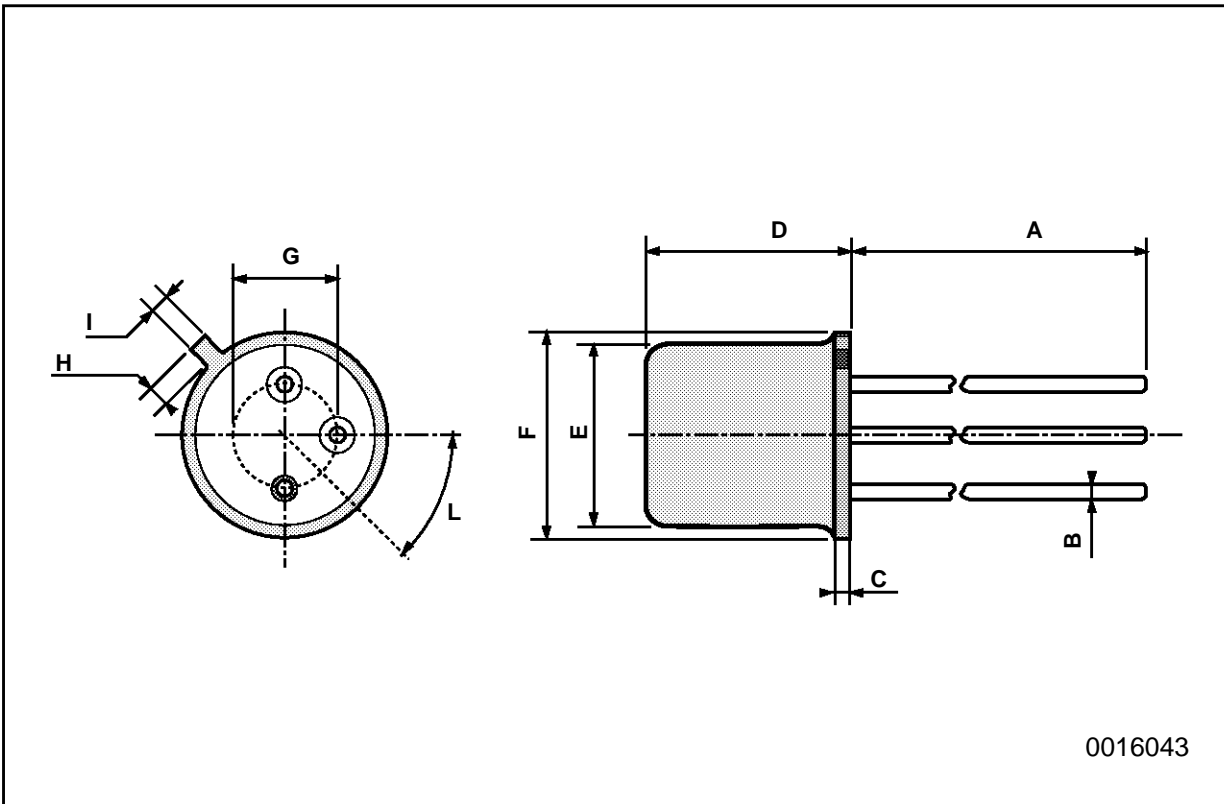

0016043

**TO39 MECHANICAL DATA**

DIM.	mm			inch		
	MIN.	TYP.	MAX.	MIN.	TYP.	MAX.
A	12.7			0.500		
B			0.49			0.019
D			6.6			0.260
E			8.5			0.334
F			9.4			0.370
G	5.08			0.200		
H			1.2			0.047
I			0.9			0.035
L	45° (typ.)					

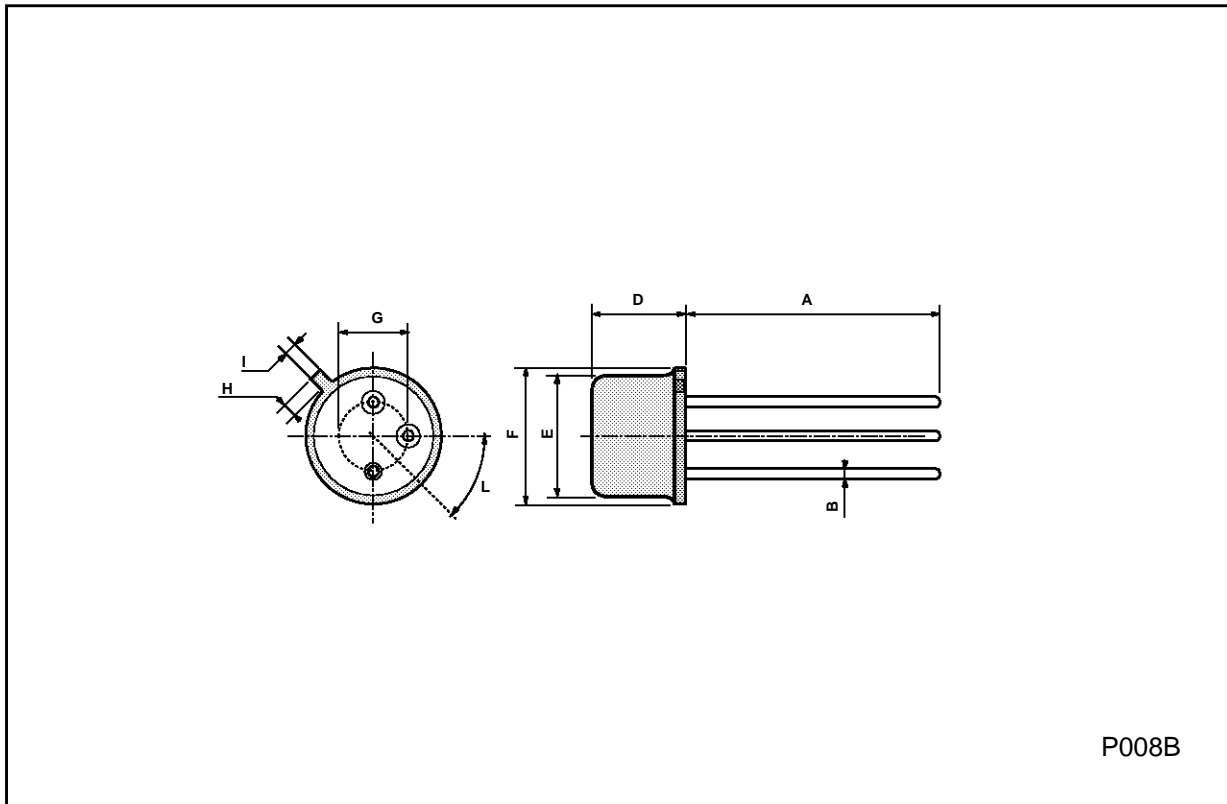

P008B

Information furnished is believed to be accurate and reliable. However, SGS-THOMSON Microelectronics assumes no responsibility for the consequences of use of such information nor for any infringement of patents or other rights of third parties which may result from its use. No license is granted by implication or otherwise under any patent or patent rights of SGS-THOMSON Microelectronics. Specifications mentioned in this publication are subject to change without notice. This publication supersedes and replaces all information previously supplied. SGS-THOMSON Microelectronics products are not authorized for use as critical components in life support devices or systems without express written approval of SGS-THOMSON Microelectronics.

© 1994 SGS-THOMSON Microelectronics - All Rights Reserved

SGS-THOMSON Microelectronics GROUP OF COMPANIES

Australia - Brazil - France - Germany - Hong Kong - Italy - Japan - Korea - Malaysia - Malta - Morocco - The Netherlands -  
Singapore - Spain - Sweden - Switzerland - Taiwan - Thailand - United Kingdom - U.S.A

## Данный компонент на территории Российской Федерации

### Вы можете приобрести в компании MosChip.

Для оперативного оформления запроса Вам необходимо перейти по данной ссылке:

<http://moschip.ru/get-element>

Вы можете разместить у нас заказ для любого Вашего проекта, будь то серийное производство или разработка единичного прибора.

В нашем ассортименте представлены ведущие мировые производители активных и пассивных электронных компонентов.

Нашей специализацией является поставка электронной компонентной базы двойного назначения, продукции таких производителей как XILINX, Intel (ex.ALTERA), Vicor, Microchip, Texas Instruments, Analog Devices, Mini-Circuits, Amphenol, Glenair.

Сотрудничество с глобальными дистрибьюторами электронных компонентов, предоставляет возможность заказывать и получать с международных складов практически любой перечень компонентов в оптимальные для Вас сроки.

На всех этапах разработки и производства наши партнеры могут получить квалифицированную поддержку опытных инженеров.

Система менеджмента качества компании отвечает требованиям в соответствии с ГОСТ Р ИСО 9001, ГОСТ РВ 0015-002 и ЭС РД 009

### Офис по работе с юридическими лицами:

105318, г.Москва, ул.Щербаковская д.3, офис 1107, 1118, ДЦ «Щербаковский»

Телефон: +7 495 668-12-70 (многоканальный)

Факс: +7 495 668-12-70 (доб.304)

E-mail: [info@moschip.ru](mailto:info@moschip.ru)

Skype отдела продаж:

moschip.ru

moschip.ru\_4

moschip.ru\_6

moschip.ru\_9