

MPU/MDU200 Series

AC-DC Power Supplies

The MPU200/MDU200 Series is based upon the proven architecture of the MPU150/MDU150 product line. The MPU products incorporate Power Factor Correction (PFC) with a low-profile package designed to meet 1U height constraints. In this series, 200 watts of continuous output power is provided with single or multiple output units suited for distributed power or central power applications. The series provides high current +3.3V and +5V on a single platform to support mixed-mode, high-speed digital circuitry.

The Bel Power Solutions dual-converter architecture combines high reliability with exceptional regulation. All multiple-output models feature remote sense on outputs V1 and V2 to provide independent compensation of output cable losses.

Other standard features include independent current sharing on V1 and V2 quad-model outputs, thermal shutdown, and remote inhibit. Airflow of 300 linear feet per minute (LFM) is required to deliver the full power density of greater than 4.0 watts per cubic inch.



Key Features & Benefits

- RoHS Compliant
- Power Factor Correction (PFC)
- Same size, airflow, and construction as MPU150/MDU150 with over 33% more power
- Single-wire current sense on quad model outputs V1 and V2
- Remote sense on quad model outputs V1 and V2
- Current share and N+1 redundancy (standard on all models)
- Overtemperature, overload, and overvoltage protection
- Available with SAE mountings
- MDU200 models have 48 VDC input

MPU/MDU200 Series

1. AC INPUT, SINGLE OUTPUT MODEL SELECTION

200W/225 W PK with 300 LFM Forced-Air Cooling ¹

MODEL ⁷	OUTPUT VOLTAGE	ADJUSTMENT RANGE	MAXIMUM OUTPUT CURRENT ²	PEAK OUTPUT CURRENT ²	LINE REGULATION	LOAD REGULATION	RIPPLE & NOISE % pk-pk ³	INITIAL SETTING ACCURACY
MPU200-1012G	12V	11.6V to 16V	17.0A	19.0A	0.1%	1%	1%	11.97V to 12.03V
MPU200-1024G	24V	22.8V to 29.2V	8.35A	9.4A	0.1%	1%	1%	23.95V to 24.05V
MPU200-1048G	48V	45V to 56V	4.2A	4.7A	0.1%	1%	1%	47.9V to 48.1V

2. AC INPUT, MULTIPLE OUTPUT MODEL SELECTION

200 W with 300 LFM Forced-Air Cooling ¹ - Isolated V3 and V4 can be used as positive or negative outputs

MODEL ⁷	OUTPUT VOLTAGE	ADJUSTMENT RANGE	MAXIMUM OUTPUT CURRENT ²	LINE REGULATION	LOAD REGULATION	RIPPLE & NOISE % pk-pk ³	INITIAL SETTING ACCURACY
MPU200-4530G	+5V	5.0V to 5.5V	30A ⁴	0.4%	1%	1%	4.98V to 5.02V
	+3.3V	3.15V to 3.60V	15A ⁴	0.6%	1.5%	1.5%	3.28V to 3.32V
	12V	10.8V to 13.2V	8A ⁵	0.4%	10%	1%	11.94V to 12.06V
	12V	10.8V to 13.2V	4A ⁵	0.4%	10%	1%	11.60V to 12.40V

3. DC INPUT, SINGLE OUTPUT MODEL SELECTION

200 W with 300 LFM Forced-Air Cooling ¹

MODEL ⁷	OUTPUT VOLTAGE	ADJUSTMENT RANGE	MAXIMUM OUTPUT CURRENT ²	PEAK OUTPUT CURRENT ²	LINE REGULATION	LOAD REGULATION	RIPPLE & NOISE % pk-pk ³	INITIAL SETTING ACCURACY
MDU200-1012G	12V	11.6V to 16V	17.0A	19.0A	0.1%	1%	1%	11.97V to 12.03V
MDU200-1024G ⁶	24V	22.8V to 29.2V	8.35A	9.4A	0.1%	1%	1%	23.95V to 24.05V
MDU200-1048G	48V	45V to 56V	4.2A	4.7A	0.1%	1%	1%	47.9V to 48.1V

Isolation Diode Option - Offered on single-output models. Add "D" at the end of the part number if an isolation diode is needed.

NOTES:

- ¹ This product is not rated for convection applications.
- ² The MPU/MDU200 products require a minimum of 300 LFM of forced-air cooling under ALL load conditions. It is recommended that the airflow be applied **from the input side of the power supply blowing towards the output**.
- ³ Maximum peak-to-peak noise expressed as a percentage of output voltage, 20 MHz bandwidth.
- ⁴ Total current for V1 and V2 is not to exceed 35A.
- ⁵ Total power on V3 and V4 is not to exceed 100W.
- ⁶ Derating is required on output voltages above 27VDC. Consult factory.
- ⁷ Non-G models use lead solder exemption and are not recommended for new designs.

4. ORDERING INFORMATION

OPTIONS	SUFFIXES TO ADD TO PART NUMBER
Metric Mounting	Add "M" as a suffix to the model number to order chassis with M3 x 0.7 mounting inserts. Consult factory for availability.
Isolation Diode	Offered on single-output models. Add "D" to the part number suffix if an isolation diode is needed. Consult factory for availability.
RoHS lead solder exempt	No RoHS suffix character required.
RoHS compliant for all 6 substances	Add "G" as the last character of the part number.

MPU/MDU200 Series

5. MPU200 INPUT SPECIFICATIONS

PARAMETER	CONDITIONS / DESCRIPTION	MIN	NOM	MAX	UNITS
Input Voltage - AC	Continuous input range.	85		264	VAC
Input Frequency	AC input.	47		63	Hz
Hold-up Time	After last AC line peak at 200 watts	15			ms
Input Current	85 VAC at full rated load.			4.0	A _{RMS}
Input Protection	Non-user serviceable internally located AC input line fuse.				
Inrush Surge Current	Internally limited by thermistor. Vin = 230 VAC, one cycle, 25°C.			35	A _{PK}
Power Factor	Per EN61000-3-2.	0.95			W/VA
Operating Frequency	Switching frequency of main output transformer.	100		120	kHz
	Switching frequency of secondary transformer.	65		90	
	Switching frequency of Power Factor Correction circuit.		60		

6. MDU200 INPUT SPECIFICATIONS

PARAMETER	CONDITIONS / DESCRIPTION	MIN	NOM	MAX	UNITS
Input Voltage - DC	Continuous input range.	36		75	VDC
Brown Out Protection	Lowest DC input voltage that regulation is maintained with full rated loads.	34			VDC
Hold-up Time	At 200 watts, over DC input range.	15			ms
Input Current	36 VDC at full rated load.			8.35	A _{RMS}
Input Protection	Non-user serviceable internally located AC input line fuse.				
Inrush Surge Current	Consult factory.				
Operating Frequency	Switching frequency of main output transformer.		100		kHz
	Switching frequency of secondary transformer.		70		

7. OUTPUT SPECIFICATIONS

PARAMETER	CONDITIONS / DESCRIPTION	MIN	NOM	MAX	UNITS
Efficiency	Full Rated Load, 110 VAC (MPU) or 48 VDC (MDU). Varies with distribution of loads among outputs.	65	75		%
Minimum Load, V1	Minimum load required to maintain regulation on, V2 at maximum load.	3			A
	Minimum load required on single output models.	0			
Minimum Load, V3	Minimum load required to maintain regulation on V4 at maximum load.	0.3			A
Ripple and Noise	Full load, 20 MHz bandwidth.				See Model Selection Charts
Overshoot / Undershoot	Output voltage overshoot/undershoot at turn-on.			5	%
Regulation	Varies by output. Total regulation includes: line changes over the specified. Input range changes in load starting at 20% load and changing to 100% load.				See Model Selection Charts
Transient Response	Recovery time, to within 1% of initial set point due to a 50-100% load change, 5% max. deviation.		500		μs
Turn-on Delay	Time required for initial output voltage stabilization.		2		s
Turn-on Rise Time	Time required for output voltage to rise from 10% to 90%.	MPU200	50		ms
		MDU200	80		

MPU/MDU200 Series

8. INTERFACE SIGNALS AND INTERNAL PROTECTION

PARAMETER	CONDITIONS / DESCRIPTION	MIN	NOM	MAX	UNITS	
Overvoltage Protection	Latch style overvoltage protection.	MPU200-4530G 3.3 V output	3.8		4.2	V
		MPU200-4530G 5 V output	6.0		6.4	
		MPU200-4530G 12 V output	14		19	
		MDU200/MPU200-1012G V1	17.0		20.5	
		MDU200/MPU200-1024G V1	32.0		38.0	
		MDU200/MPU200-1048G V1	58.0		62.7	
Overload Protection	Fully protected against output overload and short circuit. Automatic recovery upon removal of overload condition.					
Overtemperature Protection	System shutdown due to excessive internal temperature, automatic reset.					
Output Good Signal (Transition from Low to High)	TTL compatible signal available for V1. Internal pull-up resistor is 475 Ω. Signal is high when output is above the specified limits. Signal shall remain low for 20 ms following loss of Output Good.	3.3 V	3.16	3.25	V	
		5 V	4.75	4.95		
			MDU200/MPU200-1012G 12 V	10.5	11.9	V
			MDU200/MPU200-1024G 24 V	21.5	23.5	
		MDU200/MPU200-1048G 48 V	43.0	47.0		
Input Power Fail Warning	TTL compatible logic signal. Time before regulation dropout due to loss of input power. May be used as independent PSOK signal in redundant applications.	5			ms	
Current Share	Accuracy of shared current with up to 6 parallel units. Single wire current share on V1 and V2 with return via Sense return.		10		%	
Remote Sense	Available on V1 and V2. Total voltage compensation for cable losses with respect to the main output.			500	mV	
Inhibit	Output voltage is inhibited by application of an external high (5 V) signal.					

9. SAFETY, REGULATORY, AND EMI SPECIFICATIONS

PARAMETER	CONDITIONS / DESCRIPTION	MIN	NOM	MAX	UNITS
Safety Approvals	Approved to the latest edition of the following standards: CSA/UL60950-1, EN60950-1 and IEC60950-1				
Dielectric Withstand Voltage	Input to output per EN60950.	MPU200	2600		VDC
		MDU200	1414		
Electromagnetic Interference	FCC CFR title 47 Part 15 Sub-Part B - Conducted. EN55022 / CISPR 22 Conducted.	B			Class
		B			
ESD Susceptibility	Per EN61000-4-2, level 4.	8			kV
Radiated Susceptibility	Per EN61000-4-3, level 3.	10			V/M
EFT/Burst	Per EN61000-4-4, level 3.	±2			kV
Input Transient Protection	Per EN61000-4-5, class 3.	MPU200: Line to Line	1		kV
		MPU200: Line to Ground	2		
		MDU200: Line to Line	0.5		
		MDU200: Line to Ground	0.5		
Insulation Resistance	Input to Output.		10		MV
Leakage Current	Per EN60950.	MPU200 Quad Output Model		2.2	mA
		MPU200 Single Output Models		1.7	
		MDU200 at 72 VDC (Not required by EN60950)		N/A	

MPU/MDU200 Series

10. ENVIRONMENTAL SPECIFICATIONS

PARAMETER	CONDITIONS / DESCRIPTION	MIN	NOM	MAX	UNITS
Altitude	Operating. Non-Operating.			10k 40k	ASL Ft.
Operating Temperature	Derate linearly above 50°C by 2.5% per °C.	At 100% load 0 At 50% load 0		50 70	°C
Storage Temperature		-55		85	°C
Temperature Coefficient	0°C to 70°C (after 15 minute warm-up).		±0.02	±0.05	%/°C
Relative Humidity	Non-Condensing.	5		95	%RH
Shock	Peak acceleration.			20	GPK
Vibration	Random vibration, 10 Hz to 2 kHz, 3 axis.			6	G _{RMS}

11. OPTIONS

PARAMETER	CONDITIONS / DESCRIPTION
Metric Mounting	Add "M" as a suffix to the model number to order chassis with M3 x 0.7 mounting inserts. Consult factory for availability.
Isolation Diode	Offered on single-output models. Add "D" to the part number suffix if an isolation diode is needed. Consult factory for availability.

12. MECHANICAL SPECIFICATIONS

PARAMETER	DESCRIPTION
Dimensions	8.00" x 4.20" x 1.50" (203.2mm x 106.7mm x 38.1mm)
Weight:	2 lb (0.89 kg)

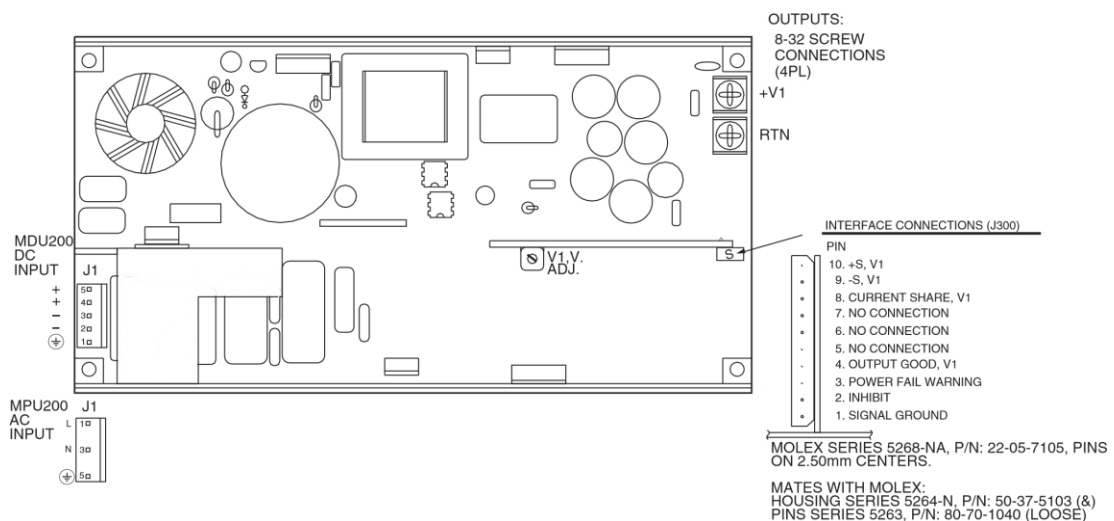

MPU/MDU200 Series

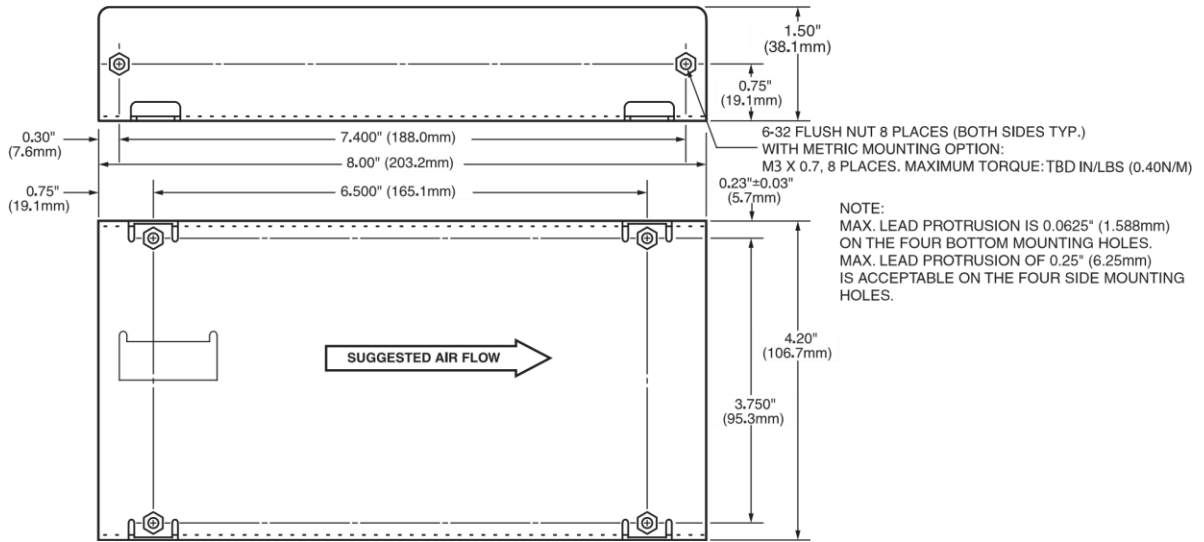
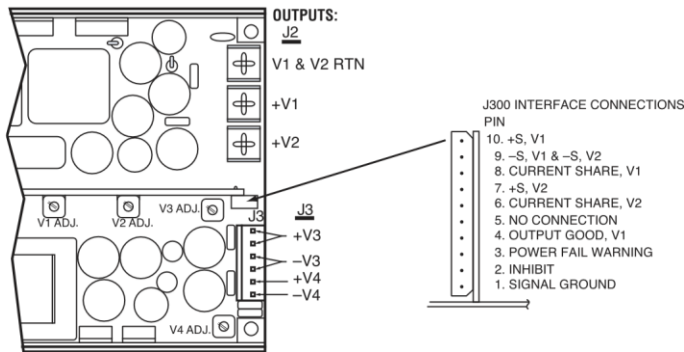

Figure 1. Mechanical Drawing – Single Output

CONNECTOR	MOLEX SERIES	HOUSING	PIN SERIES	PINS (LOOSE)	PINS (CHAIN)	WIRE GAUGE
J1 (ALL MODELS)	41695	09-50-8051	6838	08-50-0189	08-50-0187	18-20 AWG
	41695	09-50-8051	2478	08-50-0106	08-50-0105	18-20 AWG
	2139	09-50-3051	2478	08-50-0106	08-50-0105	18-20 AWG
J300	5264-N	50-37-5103	5263	08-70-1040	08-70-1039	22-28 AWG

CHASSIS: 0.063" (1.6mm) ALUMINUM ALLOY, WITH CLEAR FINISH



MPU/MDU200 Series

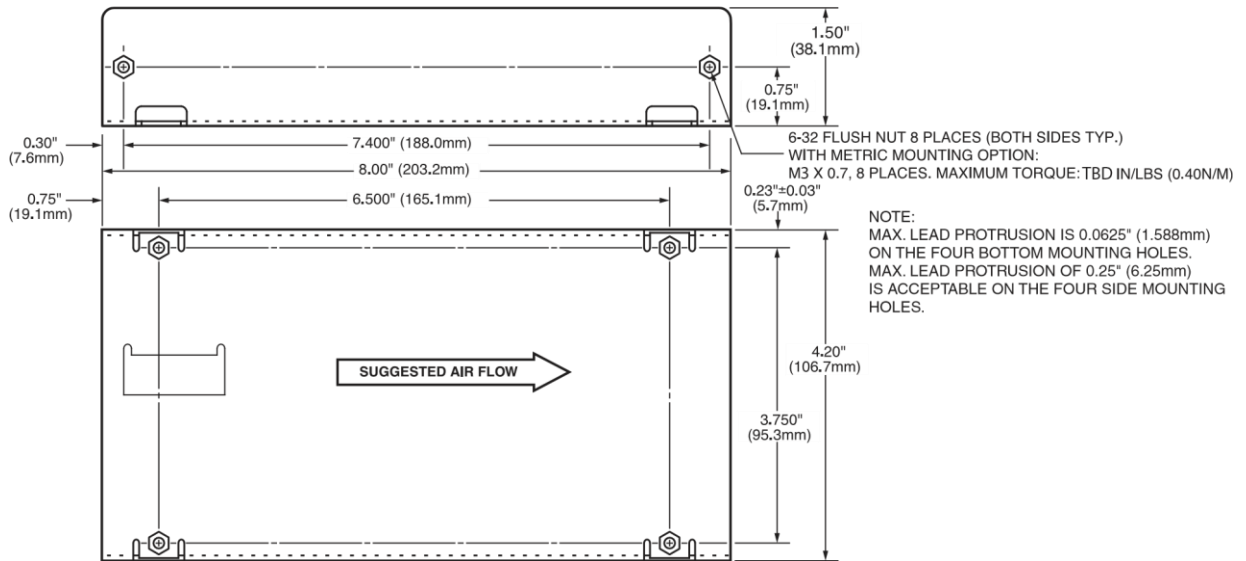

Figure 2. Mechanical Drawing – Quad Output

CONNECTOR	MOLEX SERIES	HOUSING	PIN SERIES	PINS (LOOSE)	PINS (CHAIN)	WIRE GAUGE
J1 (ALL MODELS)	41695	09-50-8051	6838	08-50-0189	08-50-0187	18-20AWG
	41695	09-50-8051	2478	08-50-0106	08-50-0105	18-20AWG
	2139	09-50-3051	2478	08-50-0106	08-50-0105	18-20AWG
J2 (TRIPLE OUTPUT)	5051-N	22-01-1022	2759	08-50-0114	08-50-0113	22-30AWG
	5051-N	22-01-1022	2759	08-65-0805	08-65-0804	22-30AWG
J3 (TRIPLE OUTPUT)	41695	09-50-8021	6838	08-50-0189	08-50-0187	18-20AWG
	41695	09-50-8021	2478	08-50-0106	08-50-0105	18-20AWG
	2139	09-50-3021	2478	08-50-0106	08-50-0105	18-20AWG
J3 (QUAD OUTPUT)	41695	09-50-8061	6838	08-50-0189	08-50-0187	18-20AWG
	41695	09-50-8061	2478	08-50-0106	08-50-0105	18-20AWG
	2139	09-50-3061	2478	08-50-0106	08-50-0105	18-20AWG
J300	5264-N	50-37-5103	5263	08-70-1040	08-70-1039	22-28AWG

CHASSIS: 0.063" (1.6mm) ALUMINUM ALLOY, WITH CLEAR FINISH

For more information on these products consult: tech.support@psbel.com

NUCLEAR AND MEDICAL APPLICATIONS - Products are not designed or intended for use as critical components in life support systems, equipment used in hazardous environments, or nuclear control systems.

TECHNICAL REVISIONS - The appearance of products, including safety agency certifications pictured on labels, may change depending on the date manufactured. Specifications are subject to change without notice.

Данный компонент на территории Российской Федерации

Вы можете приобрести в компании MosChip.

Для оперативного оформления запроса Вам необходимо перейти по данной ссылке:

<http://moschip.ru/get-element>

Вы можете разместить у нас заказ для любого Вашего проекта, будь то серийное производство или разработка единичного прибора.

В нашем ассортименте представлены ведущие мировые производители активных и пассивных электронных компонентов.

Нашей специализацией является поставка электронной компонентной базы двойного назначения, продукции таких производителей как XILINX, Intel (ex.ALTERA), Vicor, Microchip, Texas Instruments, Analog Devices, Mini-Circuits, Amphenol, Glenair.

Сотрудничество с глобальными дистрибьюторами электронных компонентов, предоставляет возможность заказывать и получать с международных складов практически любой перечень компонентов в оптимальные для Вас сроки.

На всех этапах разработки и производства наши партнеры могут получить квалифицированную поддержку опытных инженеров.

Система менеджмента качества компании отвечает требованиям в соответствии с ГОСТ Р ИСО 9001, ГОСТ РВ 0015-002 и ЭС РД 009

Офис по работе с юридическими лицами:

105318, г.Москва, ул.Щербаковская д.3, офис 1107, 1118, ДЦ «Щербаковский»

Телефон: +7 495 668-12-70 (многоканальный)

Факс: +7 495 668-12-70 (доб.304)

E-mail: info@moschip.ru

Skype отдела продаж:

moschip.ru

moschip.ru_4

moschip.ru_6

moschip.ru_9