

Analog Devices Welcomes Hittite Microwave Corporation

NO CONTENT ON THE ATTACHED DOCUMENT HAS CHANGED



THIS PAGE INTENTIONALLY LEFT BLANK



GaAs MMIC SPDT NON-REFLECTIVE SWITCH, DC - 12 GHz

Typical Applications

The HMC232ALP4E is ideal for:

- Telecom Infrastructure
- Microwave Radio & VSAT
- Military Radios, Radar & ECM
- Test Instrumentation

Features

- Isolation: 57 dB @ 3 GHz
50 dB @ 6 GHz
- Input P1dB: +30 dBm
- Insertion Loss: 1.5 dB Typical @ 6 GHz
- Non-Reflective Design
- 24 Lead 4x4mm QFN Package: 16mm²
- Included in the HMC-DK005 Designer's Kit

Functional Diagram

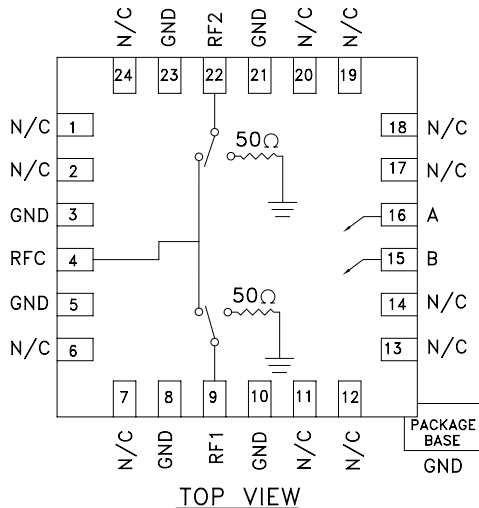

General Description

The HMC232ALP4E is a broadband high isolation non-reflective GaAs MESFET SPDT switch in a low cost leadless QFN surface mount plastic package. Covering DC to 12 GHz, the switch features >57dB isolation up to 3 GHz and >45 dB isolation up to 12 GHz. Input P1dB compression is +30 dBm typical, while input IP3 is +48 dBm. The switch operates using complementary negative control voltage logic lines of -5/0V and requires no bias supply.

Electrical Specifications, $T_A = +25^\circ C$, With 0/-5V Control, 50 Ohm System

Parameter	Frequency	Min.	Typ.	Max.	Units
Insertion Loss	DC - 3.0 GHz		1.4	1.7	dB
	DC - 6.0 GHz		1.5	1.8	dB
	DC - 9.0 GHz		2.0	2.3	dB
	DC - 12.0 GHz		2.5	3.1	dB
Isolation	DC - 3.0 GHz	52	57		dB
	DC - 6.0 GHz	45	50		dB
	DC - 9.0 GHz	42	47		dB
	DC - 12.0 GHz	40	45		dB
Return Loss	DC - 6.0 GHz		18		dB
	DC - 9.0 GHz		14		dB
	DC - 12.0 GHz		12		dB
Return Loss RF1, RF2	DC - 12.0 GHz		14		dB
Input Power for 1 dB Compression	0.5 - 12.0 GHz	26	30		dBm
Input Third Order Intercept (Two-Tone Input Power= +10 dBm Each Tone, 1 MHz Tone Separation)	0.5 - 12.0 GHz	45	48		dBm
Switching Characteristics tRISE, tFALL (10/90% RF) tON, tOFF (50% CTL to 10/90% RF)	DC - 12.0 GHz		6		ns
			25		ns



GAAS MMIC SPDT NON-REFLECTIVE SWITCH, DC - 12 GHz

Insertion Loss

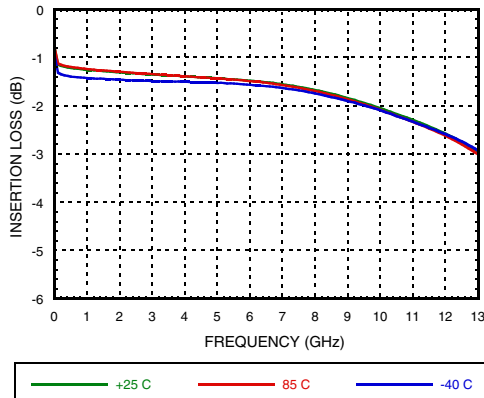

Isolation

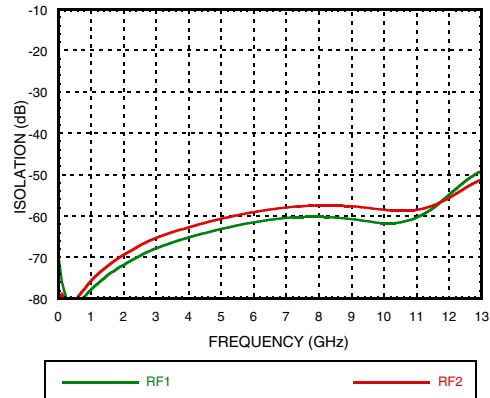

Return Loss

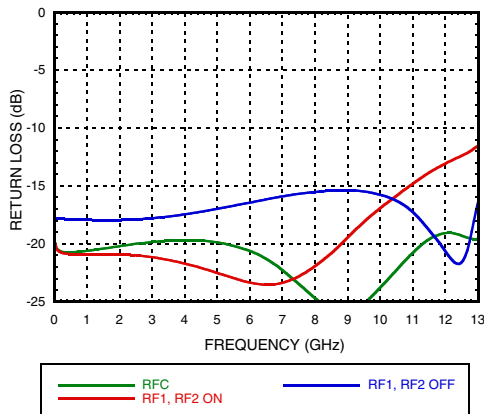

0.1 and 1 dB Input Compression Point

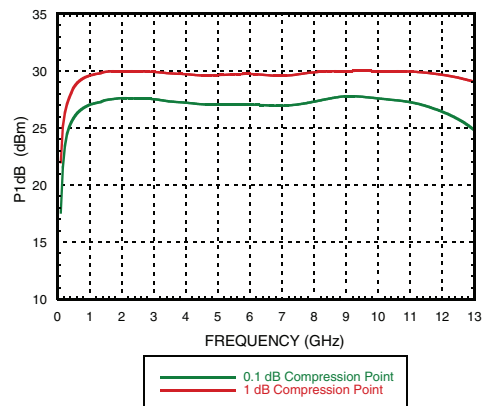

Input Third Order Intercept Point

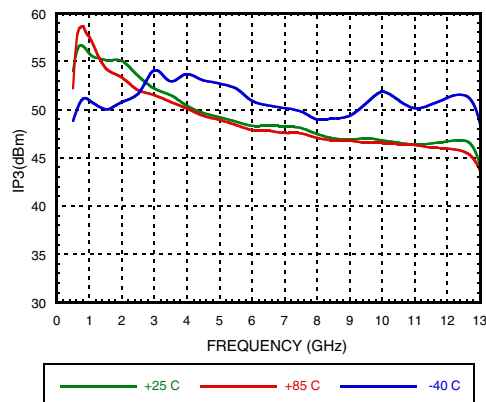



GAAS MMIC SPDT NON-REFLECTIVE SWITCH, DC - 12 GHz

Absolute Maximum Ratings

RF Input Power (Vctl = -5V) (0.5 - 12 GHz)	
Insertion Loss Path Terminated Path	+30.9 dBm +23.7 dBm
Control Voltage Range (A & B)	+1V to -7.5V
Channel Temperature	150 °C
Thermal Resistance (R _{TH}) (channel to ground paddle)	
Insertion Loss Path Terminated Path	88.5 °C/W 277 °C/W
Storage Temperature	-65 to +150 °C
Operating Temperature	-40 to +85 °C

Control Voltages

State	Bias Condition
Low	0 to -0.2V @ 0.2 uA Max.
High	-5V @ 2 uA Typ. to -7V @ 20 uA Typ. (±0.5 Vdc)

Truth Table

Control Input		Signal Path State	
A	B	RFC to RF1	RFC to RF2
High	Low	ON	OFF
Low	High	OFF	ON

Caution: Do not "Hot Switch" power levels greater than +27 dBm (Vctl = 0/-5 Vdc).



**ELECTROSTATIC SENSITIVE DEVICE
OBSERVE HANDLING PRECAUTIONS**

Outline Drawing

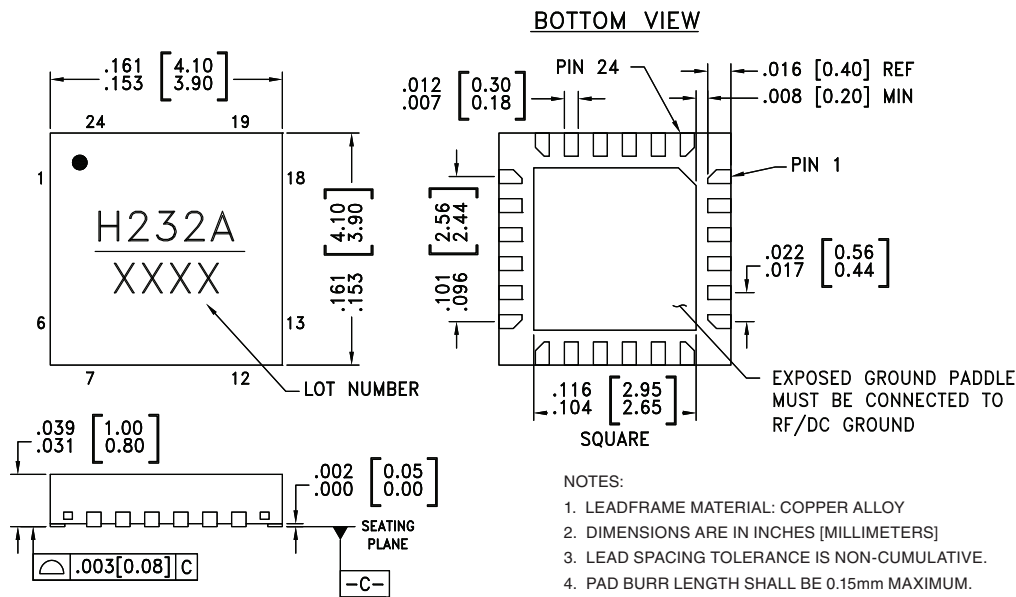

NOTES:

- LEADFRAME MATERIAL: COPPER ALLOY
- DIMENSIONS ARE IN INCHES (MILLIMETERS)
- LEAD SPACING TOLERANCE IS NON-CUMULATIVE.
- PAD BURR LENGTH SHALL BE 0.15mm MAXIMUM.
PAD BURR HEIGHT SHALL BE 0.05mm MAXIMUM.
- PACKAGE WARP SHALL NOT EXCEED 0.05mm.
- ALL GROUND LEADS AND GROUND PADDLE MUST BE SOLDERED TO PCB RF GROUND.
- REFER TO HITTITE APPLICATION NOTE FOR SUGGESTED LAND PATTERN.

Package Information

Part Number	Package Body Material	Lead Finish	MSL Rating	Package Marking [2]
HMC232ALP4E	RoHS-compliant Low Stress Injection Molded Plastic	100% matte Sn	MSL1 [1]	H232A XXXX

[1] Max peak reflow temperature of 260 °C

[2] 4-Digit lot number XXXX

Suggested Driver Circuit

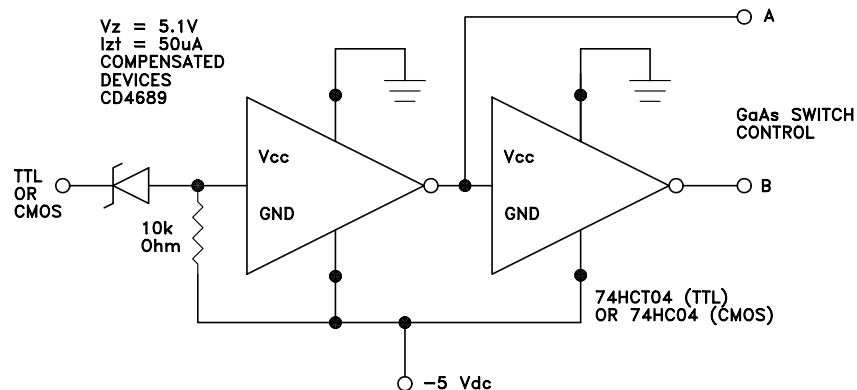

Pin Descriptions

Pin Number	Function	Description	Interface Schematic
1, 2, 6, 7, 11, 12, 13, 14, 17, 18, 19, 20, 24	N/C	The pins are not connected internally; however, all data shown herein was measured with these pins connected to RF/DC ground externally.	
3, 5, 8, 10, 21, 23	GND	Package bottom must also be connected to PCB RF ground.	
4, 9, 22	RFC, RF1, RF2	This pin is DC coupled and matched to 50 Ohm. Blocking capacitors are required if RF line potential is not equal to 0V.	
15	B	See truth table and control voltage table.	
16	A	See truth table and control voltage table.	

Evaluation PCB

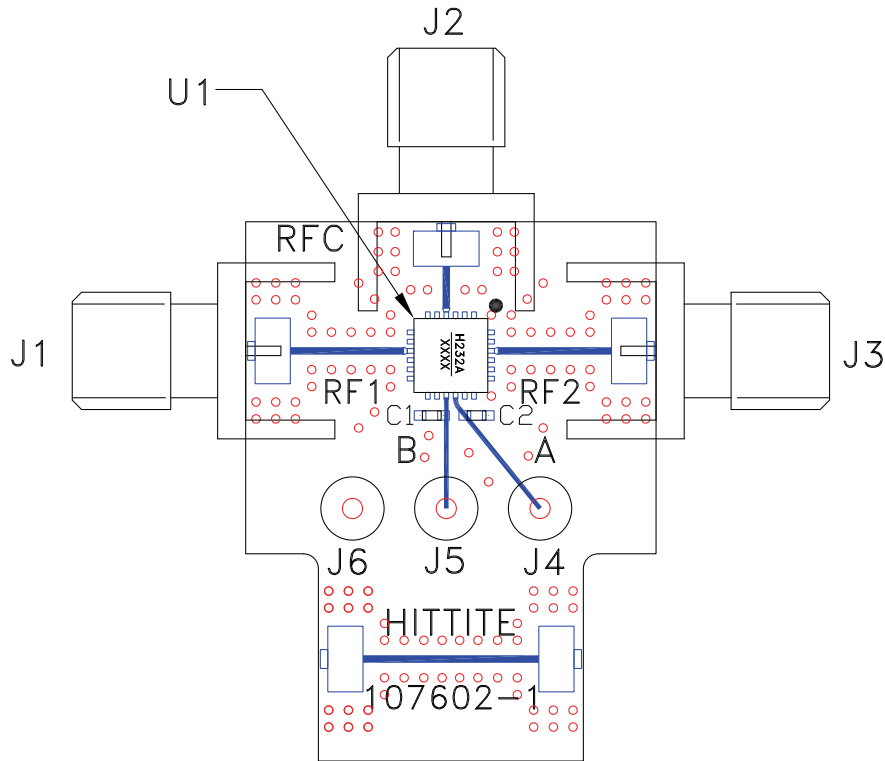

List of Materials for Evaluation PCB EV1HMC232ALP4 [1]

Item	Description
J1 - J3	PCB Mount SMA RF Connector
J4 - J6	DC Pin
C1, C2	100 pF Capacitor, 0603 Pkg.
U1	HMC232ALP4E SPDT Switch
PCB [2]	107602 Evaluation PCB

[1] Reference this number when ordering complete evaluation PCB

[2] Circuit Board Material: Rogers 4350

The circuit board used in the application should be generated with proper RF circuit design techniques. Signal lines at the RF port should have 50 Ohm impedance and the package ground leads and package bottom should be connected directly to the ground plane similar to that shown above. The evaluation circuit board shown above is available from Hittite Microwave Corporation upon request.



**GAAS MMIC SPDT NON-REFLECTIVE
SWITCH, DC - 12 GHz**

Notes:

Данный компонент на территории Российской Федерации

Вы можете приобрести в компании MosChip.

Для оперативного оформления запроса Вам необходимо перейти по данной ссылке:

<http://moschip.ru/get-element>

Вы можете разместить у нас заказ для любого Вашего проекта, будь то серийное производство или разработка единичного прибора.

В нашем ассортименте представлены ведущие мировые производители активных и пассивных электронных компонентов.

Нашей специализацией является поставка электронной компонентной базы двойного назначения, продукции таких производителей как XILINX, Intel (ex.ALTERA), Vicor, Microchip, Texas Instruments, Analog Devices, Mini-Circuits, Amphenol, Glenair.

Сотрудничество с глобальными дистрибьюторами электронных компонентов, предоставляет возможность заказывать и получать с международных складов практически любой перечень компонентов в оптимальные для Вас сроки.

На всех этапах разработки и производства наши партнеры могут получить квалифицированную поддержку опытных инженеров.

Система менеджмента качества компании отвечает требованиям в соответствии с ГОСТ Р ИСО 9001, ГОСТ РВ 0015-002 и ЭС РД 009

Офис по работе с юридическими лицами:

105318, г.Москва, ул.Щербаковская д.3, офис 1107, 1118, ДЦ «Щербаковский»

Телефон: +7 495 668-12-70 (многоканальный)

Факс: +7 495 668-12-70 (доб.304)

E-mail: info@moschip.ru

Skype отдела продаж:

moschip.ru

moschip.ru_4

moschip.ru_6

moschip.ru_9