

LAN Modular Jack Connectors

XM9B

Compact LAN Modular Jack Connectors

- Category 5e transmission performance met for 1,2-3,6 pairs. (Verified with connection to OMRON XS5W-T421.)
- Models available with and without indicators to match application needs.
- For models with indicators, no space is required on the side of the case to install a separate indicator, which saves you space.
- Structure provides EMI countermeasures.
- Lead-free.



NEW

Model Number Legend

XM9B-1 8 8 4 4 -1

(1) (2) (3) (4) (5) (6) (7)

(1) Number of Plungers

Code	Number of Plungers
1	1 plungers

(2) Number of Poles

Code	No. of Contacts
8	8

(3) Number of Mounted Contacts

Code	Installed Number
8	8

(4) Contact Plating Specification

Code	Specification
4	Gold Flash Plating

(5) Terminal Shape

Code	Shape
4	Side entry (right-angle terminals)

(6) Shielding Plate Specification

Code	Specification
1	With shielding plate

(7) Indicator Specification

Code	Specification
0	Without indicator
1	With indicator

Ratings and Characteristics

Rated current	1.5A
Rated voltage	250 VAC
Contact resistance	20 mΩ max.
Insulation resistance	500 MΩ min.
Withstand voltage	500 VAC for 1 min (leakage current: 0.5 mA max.)
Insertion durability	750 times
Operating temperature	-45 to 80°C (With no icing at low temperature)



Note: Refer to the product specifications for details.

Materials and Finish

Housing	PBT resin (UL94 V-0)/black	
Contacts	Mating end	Phosphor bronze/nickel base, flash gold plated
	Terminals	Phosphor bronze/nickel base, flash gold plated
Shell	Brass/nickel plated	

Note: Refer to the product specifications for details.

Ordering Information

Appearance		
Indicator	Without indicator	With indicator
Model	XM9B-18844-10	XM9B-18844-11

XM9B

Dimensions

(Unit: mm)

XM9B-18844-10

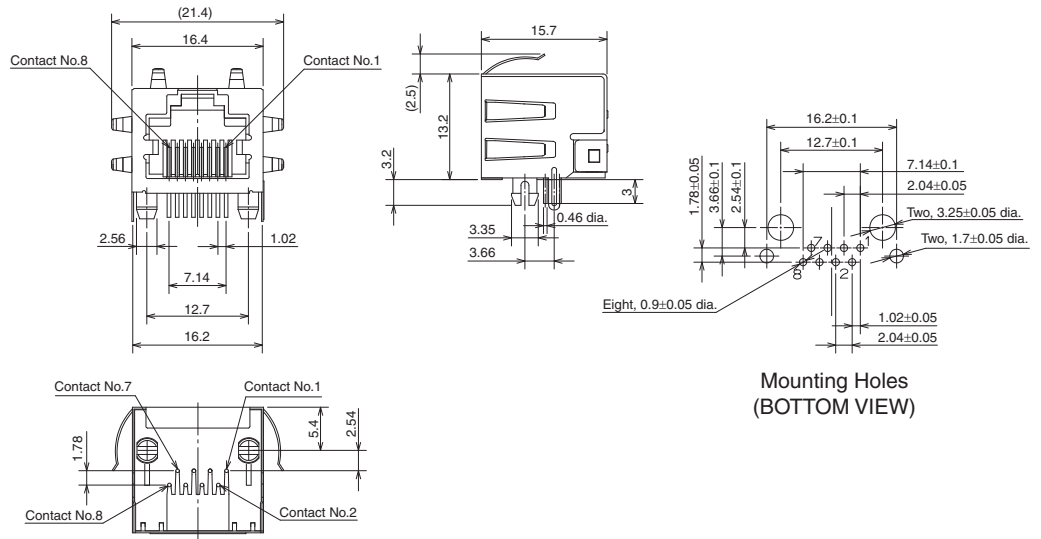

XM9B-18844-11

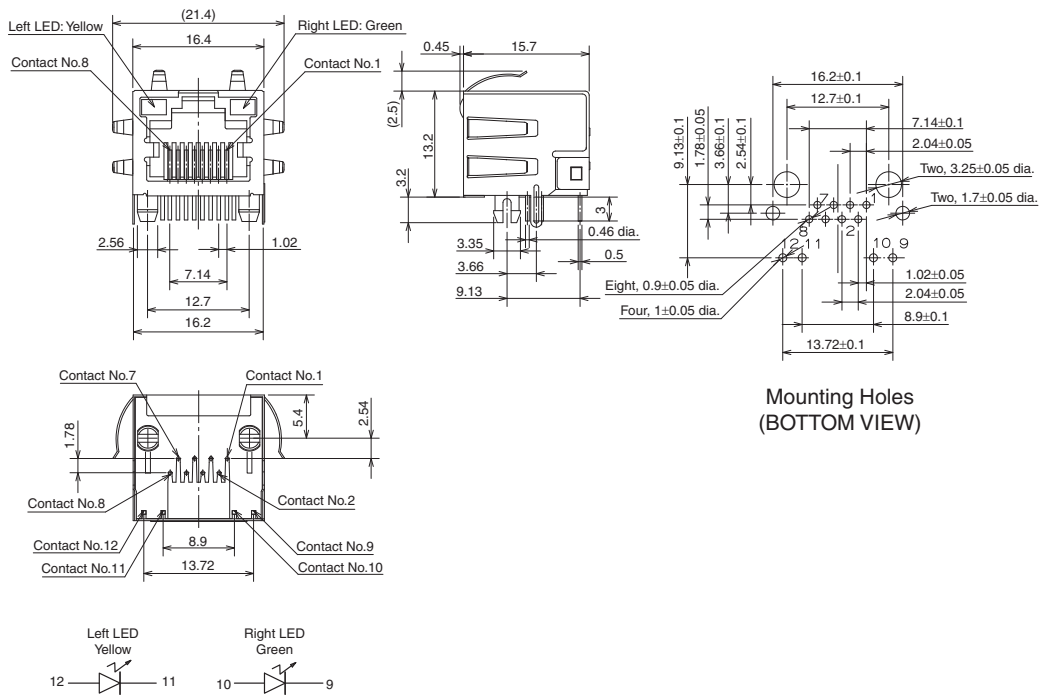

Safety Precautions

Precautions for Correct Use

Do not use the product in any atmosphere or environment that exceeds the ratings.

●Automatic Soldering

Automated Soldering Conditions (Jet Flow)

- (1) Soldering temperature: $250 \pm 5^{\circ}\text{C}$
- (2) Continuous soldering time: within 5 ± 1 s

●Storage

Do not store the Connectors in locations subject to dust or high humidity. Do not store the Connectors in locations close to sources of gasses such ammonia gas or sulfide gas.

●Terminal Shapes

The terminals will deform if they are subjected to an excessive load, which will in turn reduce solderability when mounting. Do not drop the Connectors or handle them carelessly. Do not connect anything when the Connectors are not mounted to a board. Doing so may deform the terminals.

●Using an Automatic Solder Bath

Mask the mating portion with tape before you perform automatic soldering to prevent flux or solder from entering the mating portion of the Connector. Select and use a suitable masking tape.

●Application Precautions

- Confirm that there is no excessive misalignment or inclination in the mating contact portion between the plug and socket before mating the Connector. Make sure that the Connector is mated all the way to the back. If the Connector is not mated all the way to the back, contact reliability may be lost.
- Do not apply an extreme load during Connector insertion or removal. The Connector may be damaged, and contact failure may result. Twist the plug and socket as little as possible when mating the Connector. Not doing so may deform the terminals or housing or crack the housing.
- Do not insert a foreign object, such as tweezers, into the Connector mating contact portion. Doing so may cause the plating to peel off or deform the terminals.

- Application examples provided in this document are for reference only. In actual applications, confirm equipment functions and safety before using the product.
- Consult your OMRON representative before using the product under conditions which are not described in the manual or applying the product to nuclear control systems, railroad systems, aviation systems, vehicles, combustion systems, medical equipment, amusement machines, safety equipment, and other systems or equipment that may have a serious influence on lives and property if used improperly. Make sure that the ratings and performance characteristics of the product provide a margin of safety for the system or equipment, and be sure to provide the system or equipment with double safety mechanisms.

Note: Do not use this document to operate the Unit.

Данный компонент на территории Российской Федерации

Вы можете приобрести в компании MosChip.

Для оперативного оформления запроса Вам необходимо перейти по данной ссылке:

<http://moschip.ru/get-element>

Вы можете разместить у нас заказ для любого Вашего проекта, будь то серийное производство или разработка единичного прибора.

В нашем ассортименте представлены ведущие мировые производители активных и пассивных электронных компонентов.

Нашей специализацией является поставка электронной компонентной базы двойного назначения, продукции таких производителей как XILINX, Intel (ex.ALTERA), Vicor, Microchip, Texas Instruments, Analog Devices, Mini-Circuits, Amphenol, Glenair.

Сотрудничество с глобальными дистрибьюторами электронных компонентов, предоставляет возможность заказывать и получать с международных складов практически любой перечень компонентов в оптимальные для Вас сроки.

На всех этапах разработки и производства наши партнеры могут получить квалифицированную поддержку опытных инженеров.

Система менеджмента качества компании отвечает требованиям в соответствии с ГОСТ Р ИСО 9001, ГОСТ РВ 0015-002 и ЭС РД 009

Офис по работе с юридическими лицами:

105318, г.Москва, ул.Щербаковская д.3, офис 1107, 1118, ДЦ «Щербаковский»

Телефон: +7 495 668-12-70 (многоканальный)

Факс: +7 495 668-12-70 (доб.304)

E-mail: info@moschip.ru

Skype отдела продаж:

moschip.ru

moschip.ru_4

moschip.ru_6

moschip.ru_9