

# XB Supercapacitors

## Cylindrical snap-in



### Features

- Over 10-year operating life at room temperature
- Low ESR for high power density
- Large capacitance for high energy density
- Long cycle life
- Environmentally friendly electrolyte
- UL Recognized

### Applications

- Hybrid battery or fuel cell systems
- High pulse current applications
- UPS / hold-up power

### Description

Eaton supercapacitors are unique, ultra-high capacitance devices utilizing electrochemical double layer capacitor (EDLC) construction combined with new, high performance materials. This combination of advanced technologies allows Eaton to offer a wide variety of capacitor solutions tailored to specific applications that range from a few micro-amps for several days to several amps for milliseconds.

## Ratings

Capacitance	300 F to 600 F
Maximum working voltage	2.5 V
Surge voltage	2.85 V
Capacitance tolerance	-10% to +10% (+20 °C)
Operating temperature range	-25 °C to +70 °C

## Specifications

Capacitance <sup>1</sup> (F)	Part Number	Maximum ESR <sup>1</sup> (mΩ) (Equivalent Series Resistance)	Max continuous current <sup>2</sup> (A)	Peak current <sup>3</sup> (A)	Max leakage current <sup>1,4</sup> (mA)	Max power <sup>5</sup> (W)	Stored energy <sup>6</sup> (Wh)	Typical mass (g)
300	XB3550-2R5307-R	7	15	120	0.30	220	0.26	69
400	XB3560-2R5407-R	4.5	19	180	0.45	350	0.35	80
600	XB3585-2R5607-R	3.7	29	235	0.70	420	0.52	122

1. Capacitance, ESR and Leakage current are all measured according to IEC 62391-1 at +20 °C
2. 15 °C Temperature Rise
3. Peak Current is for 1 second =  $\frac{1}{2}$  Working Voltage x Capacitance / (1 + ESR x Capacitance)
4. Leakage current measured after 72 hours, +20 °C
5. Max. Power = Working Voltage<sup>2</sup> / 4 / ESR
6. Stored energy =  $\frac{1}{2}$  Capacitance x Working Voltage<sup>2</sup> / 3600

## Performance

Parameter		Capacitance change (% of initial value)	ESR (% of max. initial value)
Life			
@ Maximum operating voltage and temp)	1500 hours	≤ 20%	≤ 200%
Charge/discharge cycling <sup>1</sup>	500,000	≤ 20%	≤ 200%
Storage Life- uncharged			
-25 °C to +70 °C	1500 hours	≤ 20%	≤ 200%
≤ 30°C	3 years	≤ 5%	≤ 10%

1. Cycling between maximum operating and 50% of maximum operating voltage at room temperature

**Dimensions- mm**

**Dimensions - mm**

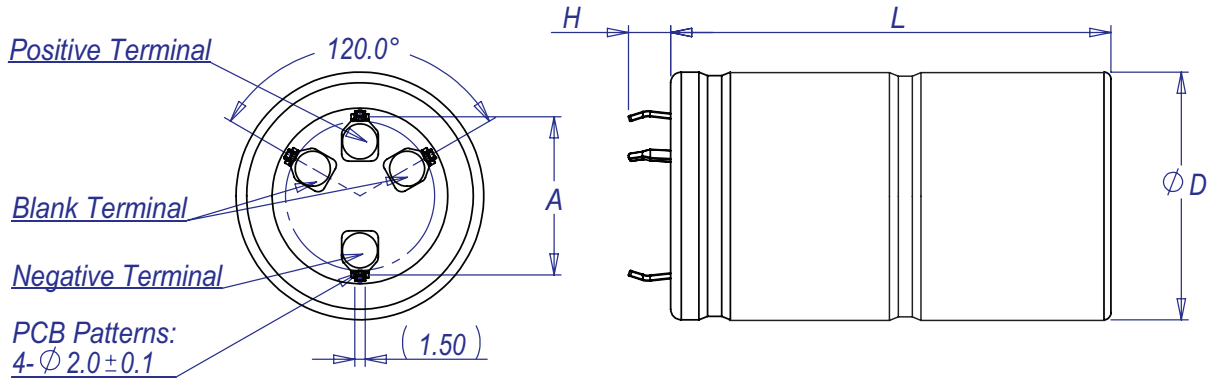

Part number	D $\pm 1.0$	L $\pm 1.0$	H $\pm 1.0$	A $\pm 0.1$
XB3550-2R5307-R	35	53	6	22.5
XB3560-2R5407-R	35	63	6	22.5
XB3585-2R5607-R	35	87.5	6	22.5

**Part numbering system**

<b>XB</b>	<b>3560</b>		<b>-2R5</b>	<b>40</b>	<b>7</b>	<b>-R</b>
Family Code	Size reference- mm		Voltage (V) R = Decimal	Capacitance ( $\mu$ F)		Standard product
	Diameter	Length		Value	Multiplier	
XB=Family Code	35	60	2R5 = 2.5 V	Example: 407 = 40 x 10 <sup>7</sup> $\mu$ F or 400 F		

**Packaging information**

- Standard packaging: Bulk, 20 parts per box

**Part marking**

- Manufacturer
- Capacitance (F)
- Maximum operating voltage (V)
- Family code (or part number)
- Polarity

**Wave solder profile**

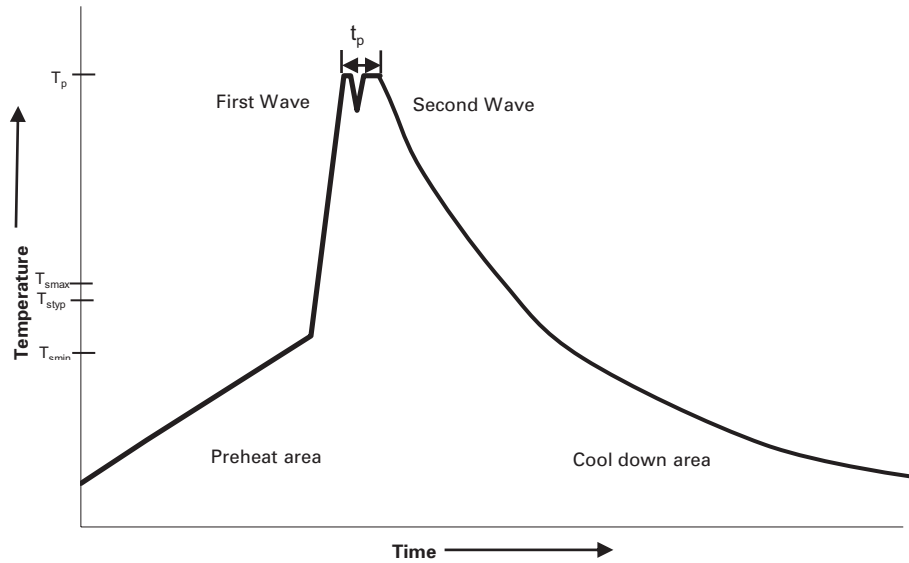

Profile Feature	Standard SnPb Solder	Lead (Pb) Free Solder
Preheat and soak	<ul style="list-style-type: none"> <li>• Temperature max. (<math>T_{smax}</math>)</li> <li>• Time max.</li> </ul>	<ul style="list-style-type: none"> <li>• Temperature max. (<math>T_{smax}</math>)</li> <li>• Time max.</li> </ul>
$\Delta$ preheat to max Temperature	160 °C max.	160 °C max.
Peak temperature ( $T_p$ )*	220 °C – 260 °C	250 °C – 260 °C
Time at peak temperature ( $t_p$ )	10 seconds max 5 seconds max each wave	10 seconds max 5 seconds max each wave
Ramp-down rate	~ 2 K/s min ~3.5 K/s typ ~5 K/s max	~ 2 K/s min ~3.5 K/s typ ~5 K/s max
Time 25 °C to 25 °C	4 minutes	4 minutes

**Manual solder**

+350 °C, 4-5 seconds. (by soldering iron), generally manual, hand soldering is not recommended.

**Reflow soldering**

Do not use reflow soldering using infrared or convection oven heating methods.

**Cleaning/Washing**

Avoid cleaning of circuit boards, however if the circuit board must be cleaned use static or ultrasonic immersion in a standard circuit board cleaning fluid for no more than 5 minutes and a maximum temperature of +60 °C. Afterwards thoroughly rinse and dry the circuit boards. In general, treat supercapacitors in the same manner you would an aluminum electrolytic capacitor.

Life Support Policy: Eaton does not authorize the use of any of its products for use in life support devices or systems without the express written approval of an officer of the Company. Life support systems are devices which support or sustain life, and whose failure to perform, when properly used in accordance with instructions for use provided in the labeling, can be reasonably expected to result in significant injury to the user.

Eaton reserves the right, without notice, to change design or construction of any products and to discontinue or limit distribution of any products. Eaton also reserves the right to change or update, without notice, any technical information contained in this bulletin.

**Eaton**  
**Electronics Division**  
1000 Eaton Boulevard  
Cleveland, OH 44122  
United States  
www.eaton.com/electronics

© 2017 Eaton  
All Rights Reserved  
Printed in USA  
Publication No. 4423  
October 2017

## Данный компонент на территории Российской Федерации

### Вы можете приобрести в компании MosChip.

Для оперативного оформления запроса Вам необходимо перейти по данной ссылке:

<http://moschip.ru/get-element>

Вы можете разместить у нас заказ для любого Вашего проекта, будь то серийное производство или разработка единичного прибора.

В нашем ассортименте представлены ведущие мировые производители активных и пассивных электронных компонентов.

Нашей специализацией является поставка электронной компонентной базы двойного назначения, продукции таких производителей как XILINX, Intel (ex.ALTERA), Vicor, Microchip, Texas Instruments, Analog Devices, Mini-Circuits, Amphenol, Glenair.

Сотрудничество с глобальными дистрибьюторами электронных компонентов, предоставляет возможность заказывать и получать с международных складов практически любой перечень компонентов в оптимальные для Вас сроки.

На всех этапах разработки и производства наши партнеры могут получить квалифицированную поддержку опытных инженеров.

Система менеджмента качества компании отвечает требованиям в соответствии с ГОСТ Р ИСО 9001, ГОСТ РВ 0015-002 и ЭС РД 009

### Офис по работе с юридическими лицами:

105318, г.Москва, ул.Щербаковская д.3, офис 1107, 1118, ДЦ «Щербаковский»

Телефон: +7 495 668-12-70 (многоканальный)

Факс: +7 495 668-12-70 (доб.304)

E-mail: [info@moschip.ru](mailto:info@moschip.ru)

Skype отдела продаж:

moschip.ru

moschip.ru\_4

moschip.ru\_6

moschip.ru\_9