

Analog Devices Welcomes Hittite Microwave Corporation

NO CONTENT ON THE ATTACHED DOCUMENT HAS CHANGED



THIS PAGE INTENTIONALLY LEFT BLANK



SUCCESSIVE DETECTION LOG VIDEO AMPLIFIER (SDLVA), 0.6 - 20 GHz

Typical Applications

The HMC913 is ideal for:

- EW, ELINT & IFM Receivers
- DF Radar Systems
- ECM Systems
- Broadband Test & Measurement
- Power Measurement & Control Circuits
- Military & Space Applications

Functional Diagram

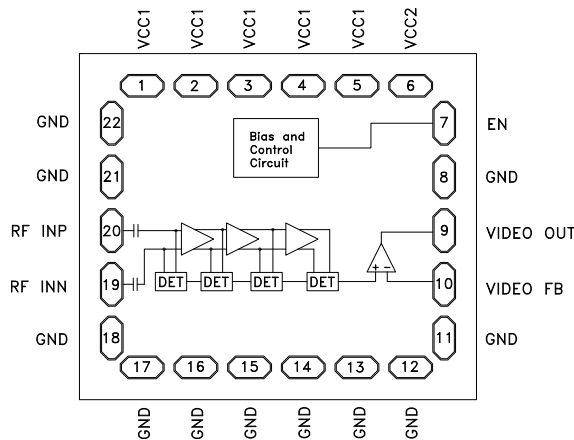

Features

- High Logging Range: 59 dB (-54 to +5 dBm) @ 18 GHz
- Output Frequency Flatness: ± 1.5 dB
- Log Linearity: ± 1 dB
- Fast Rise/Fall Times: 5/10 ns
- Single Positive Supply: +3.3V
- ESD Sensitivity (HBM): Class 1A

General Description

The HMC913 is a Successive Detection Log Video Amplifier (SDLVA) which operates from 0.6 to 20 GHz. The HMC913 provides a logging range of 59 dB. This device offers typical fast rise/fall times of 5/10 ns and a superior delay time of only 14 ns. The HMC913 log video output slope is typically 14 mV/dB. Maximum recovery times are less than 30 ns. Ideal for high speed channelized receiver applications, the HMC913 operates from a single +3.3 V supply, and consumes only 80 mA. All data shown herein is measured with the chip in a 50 Ohm environment and contacted with RF probes.

Electrical Specifications, $T_A = +25^\circ\text{C}$, $V_{cc1} = V_{cc2} = 3.3\text{V}$ [1]

| Parameter | Conditions | Typ. | Units |
|---|------------------------------|--------------|--------------------------------|
| Input Frequency Range [1][2] | | 0.6 - 20 | GHz |
| Frequency Flatness | Pin = -25 dBm | ± 1.5 | dB |
| Log Linearity | Pin = -50 to +3 dBm | ± 1 | dB |
| Log Linearity over Temperature (-55 °C to +85 °C) | Pin = -25 dBm | ± 1.5 | dB |
| Minimum Logging Range | to ± 3 dB error @ 18 GHz | -54 @ 18 GHz | dBm |
| Maximum Logging Range | to ± 3 dB error @ 18 GHz | +5 @ 18 GHz | dBm |
| Input Return Loss | | 5.5 | dB |
| Log Video Minimum Output Voltage | | 1 | V |
| Log Video Maximum Output Voltage | | 1.8 | V |
| Log Video Output Rise Time | 10% to 90% | 5 | ns |
| Log Video Output Fall Time | 90% to 10% | 10 | ns |
| Log Video Recovery Time | | 25 | ns |
| Log Video Output Slope | | 14 | mV/dB |
| Log Video Output Slope Variation over Temperature | @ 10 GHz | 5 | $\mu\text{V/dB}^\circ\text{C}$ |
| Log Video Propagation Delay | | 14 | ns |
| Supply Current ($I_{cc1} + I_{cc2}$) | @ Pin = -30 dBm | 80 | mA |

[1] Electrical specs and performance plots are given for single-ended operation

[2] Video output load should be 1K Ohm or higher.



SUCCESSIVE DETECTION LOG VIDEO AMPLIFIER (SDLVA), 0.6 - 20 GHz

Error Flatness vs. Input Power Over Frequency ^{[1][2]}

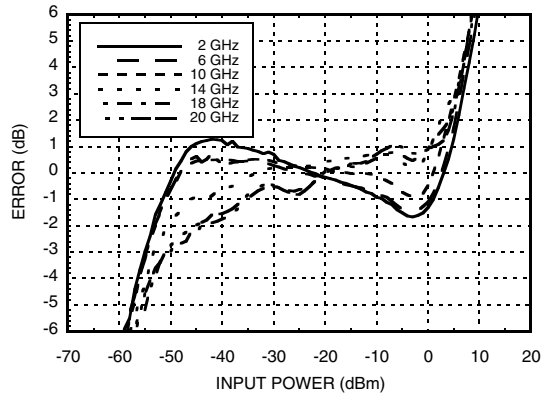

VIDEO OUT & Error vs. Input Power, Fin = 500 MHz ^[1]

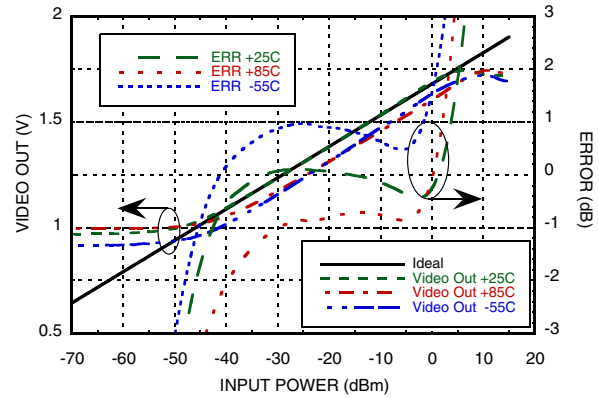

VIDEO OUT & Error vs. Input Power, Fin = 1 GHz ^[1]

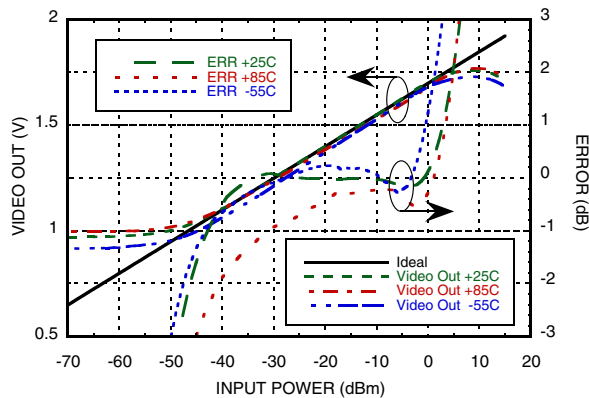

VIDEO OUT & Error vs. Input Power, Fin = 2 GHz ^[1]

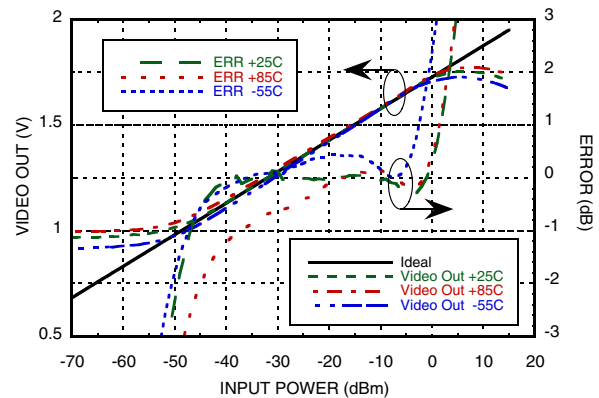

VIDEO OUT & Error vs. Input Power, Fin = 6 GHz ^[1]

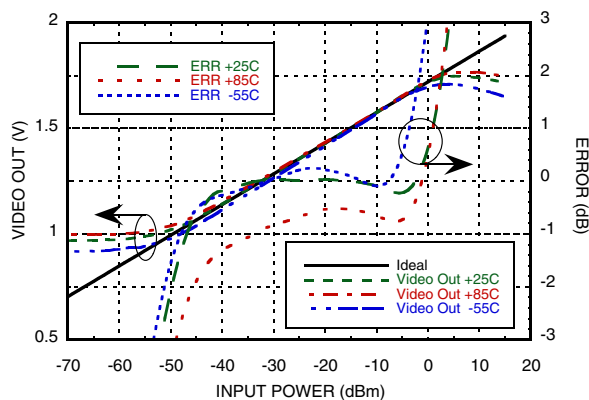

VIDEO OUT & Error vs. Input Power, Fin = 10 GHz ^[1]

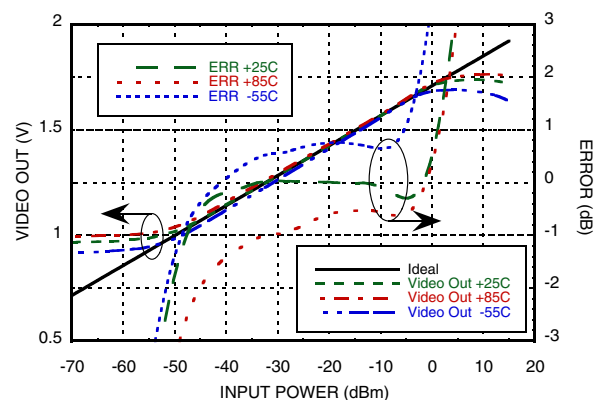

[1] Electrical specs and performance plots are given for single-ended operation

[2] An average ideal line is used to calculate error curves.



SUCCESSIVE DETECTION LOG VIDEO AMPLIFIER (SDLVA), 0.6 - 20 GHz

VIDEO OUT & Error vs. Input Power, $F_{in} = 14$ GHz [1]

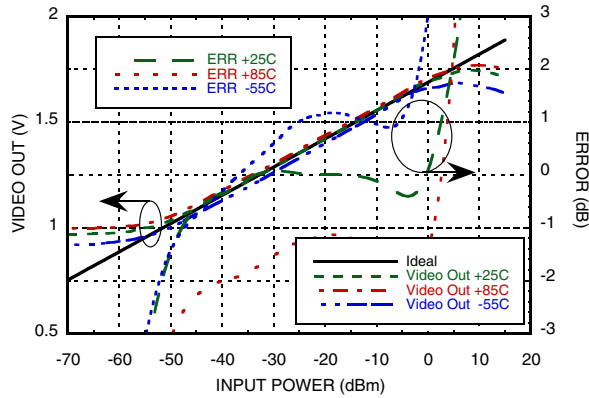

VIDEO OUT vs. Error vs. Input Power, $F_{in} = 18$ GHz [1]

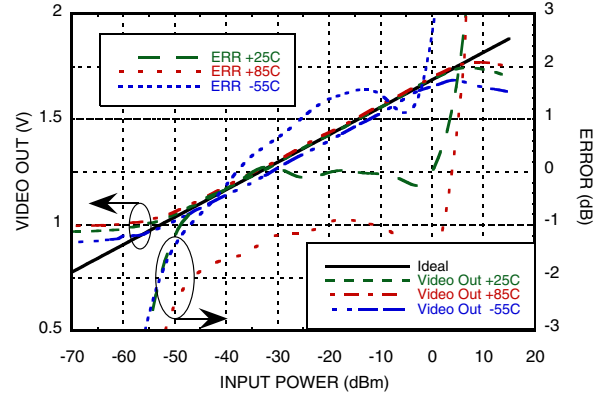

VIDEO OUT & Error vs. Input Power, $F_{in} = 20$ GHz [1]

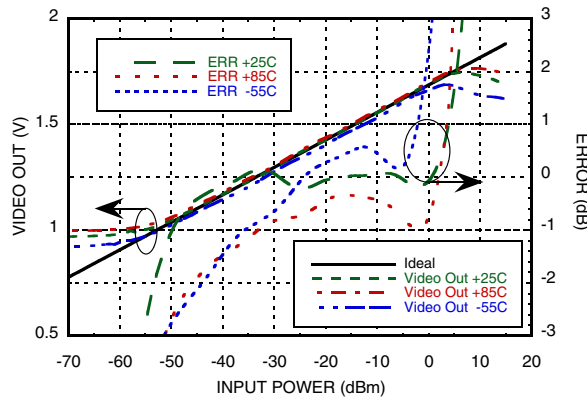

VIDEO OUT vs. Frequency Over Input Power & Temperature [1]

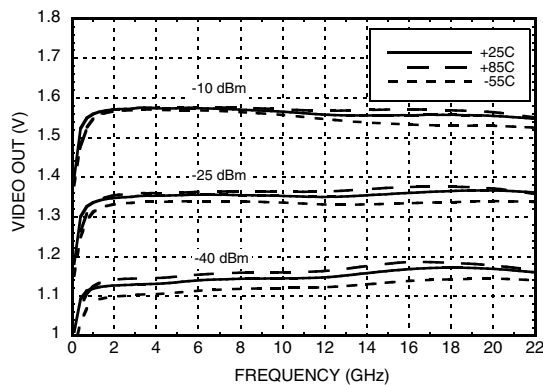

VIDEO OUT vs. Frequency Over Input Power & Bias Voltage [1]

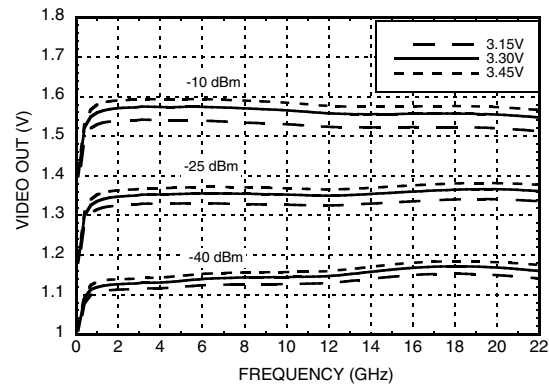

[1] Electrical specs and performance plots are given for single-ended operation



SUCCESSIVE DETECTION LOG VIDEO AMPLIFIER (SDLVA), 0.6 - 20 GHz

Rise Time for Various Frequencies @ 0 dBm ^[1]

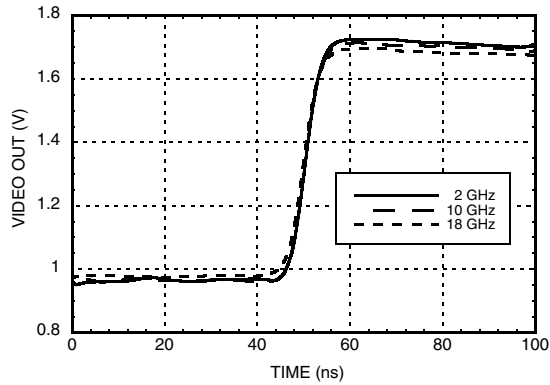

Fall Time for Various Frequencies @ 0 dBm ^[1]

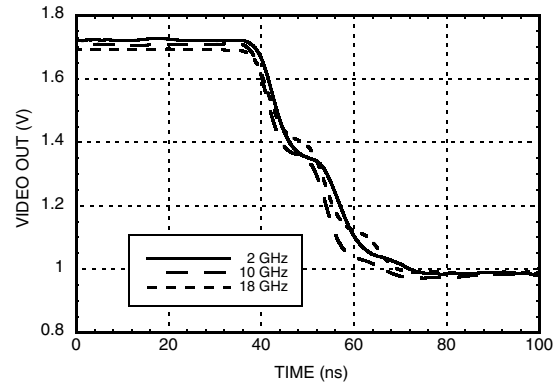

Input Return Loss vs. Frequency ^[1]

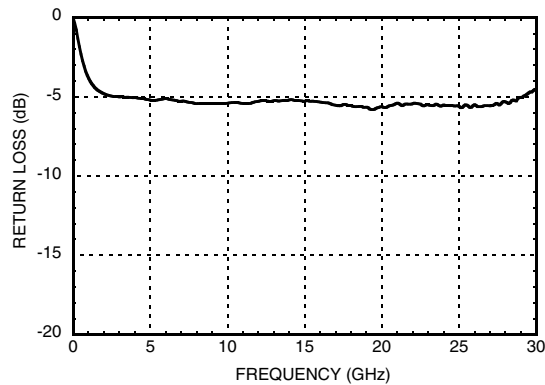

[1] Electrical specs and performance plots are given for single-ended operation



SUCCESSIVE DETECTION LOG VIDEO AMPLIFIER (SDLVA), 0.6 - 20 GHz

Absolute Maximum Ratings

| | |
|--|----------------|
| Vcc | +3.6V |
| ENBL | +3.6V |
| RF Input Power | +15 dBm |
| Channel Temperature | 125 °C |
| Continuous P _{diss} (T=85°C) Derate 12.63 mW/°C above 85°C | 0.51 W |
| Thermal Resistance R _{th} (Junction to die bottom) | 33.94 °C/W |
| Storage Temperature | -65 to +150 °C |
| Operating Temperature | -55 to +85 °C |
| ESD Sensitivity (HBM) | Class 1A |

Die Packaging Information [1]

| Standard | Alternate |
|--------------------|-----------|
| WP-3 (Waffle Pack) | [2] |

[1] Refer to the "Packaging Information" section for die packaging dimensions.

[2] For alternate packaging information contact Hittite Microwave Corporation.

NOTES:

1. ALL DIMENSIONS IN INCHES [MILLIMETERS]
2. DIE THICKNESS IS 0.011 (0.279)
3. TYPICAL BOND PAD IS 0.0024 SQUARE
4. BOND PAD METALLIZATION: ALUMINUM
5. NO BACKSIDE METAL
6. NO CONNECTION REQUIRED FOR UNLABELED BOND PADS
7. OVERALL DIE SIZE IS ±.002



**ELECTROSTATIC SENSITIVE DEVICE
OBSERVE HANDLING PRECAUTIONS**

Outline Drawing

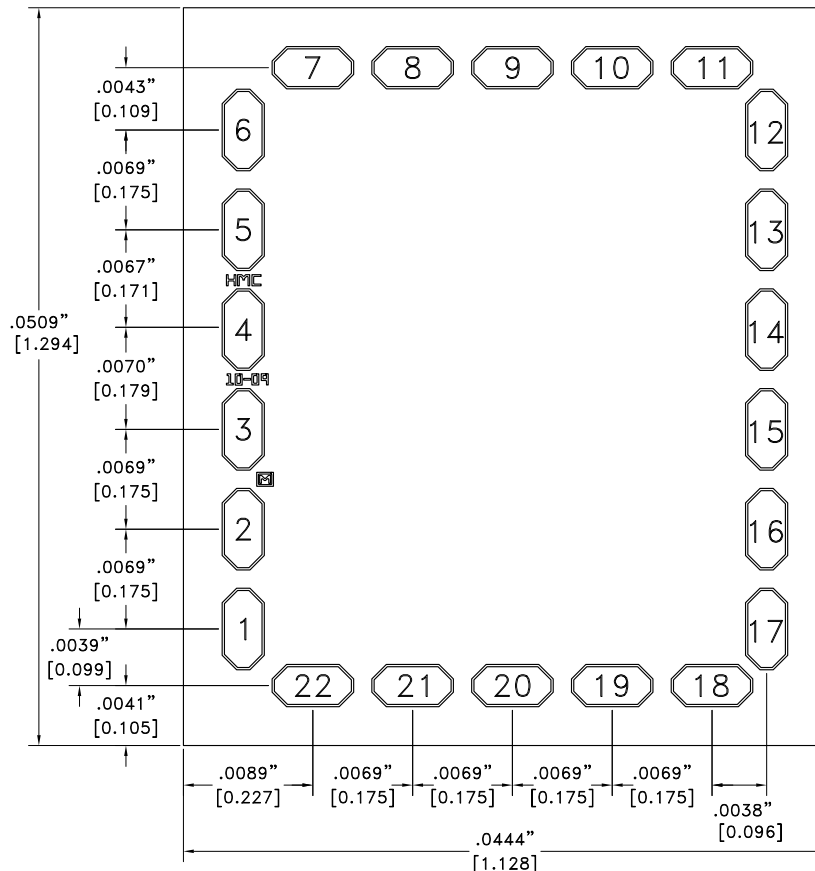

**SUCCESSIVE DETECTION LOG VIDEO
AMPLIFIER (SDLVA), 0.6 - 20 GHz**
Pad Descriptions

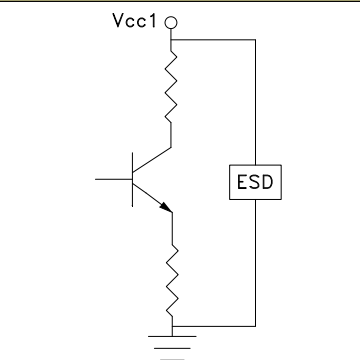
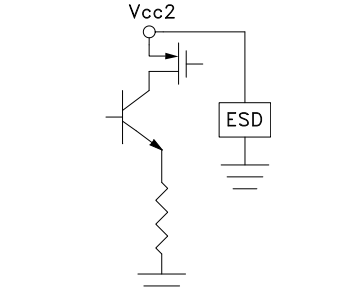
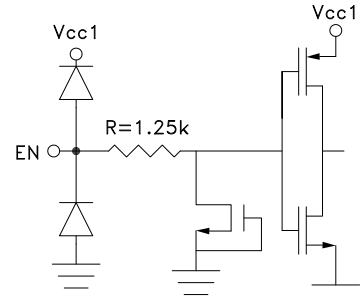
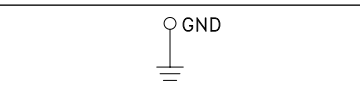
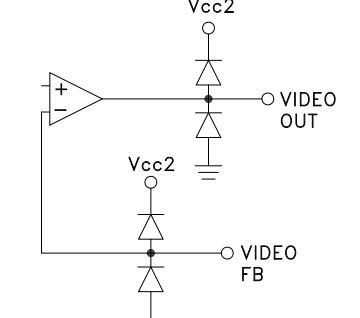
| Pad Number | Function | Description | Interface Schematic |
|----------------------------------|------------------------|---|---|
| 1 - 5 | VCC1 | Bias Supply. Connect Supply Voltage to these pins with appropriate filtering. To ensure proper start-up supply rise time should be faster than 100usec |  |
| 6 | VCC2 | Bias Supply. Connect supply voltage to these pins with appropriate filtering. To ensure proper start-up supply rise time should be faster than 100usec |  |
| 7 | EN | Enable pin connected to VCC1 or VCC2 for normal operation. Total supply current reduced to less than 3mA when EN is set to 0V. |  |
| 8, 11 - 18, 21, 22 Die Bottom | GND | These pins and the die bottom must be connected to a high quality RF/DC ground. |  |
| 9, 10 | VIDEO OUT, VIDEO FB | Video out and feedback. These pins should be shorted to each other (see application circuit). Video out load should be at least 1K Ohm or higher. |  |



SUCCESSIVE DETECTION LOG VIDEO AMPLIFIER (SDLVA), 0.6 - 20 GHz

Pad Descriptions (Continued)

| Pad Number | Function | Description | Interface Schematic |
|------------|--------------|--|---------------------|
| 19, 20 | RFINN, RFINP | RF Input pins Connect RF to RFINP and AC couple RFINN to ground via 50 Ohm for single ended operation. | |

Application Circuit

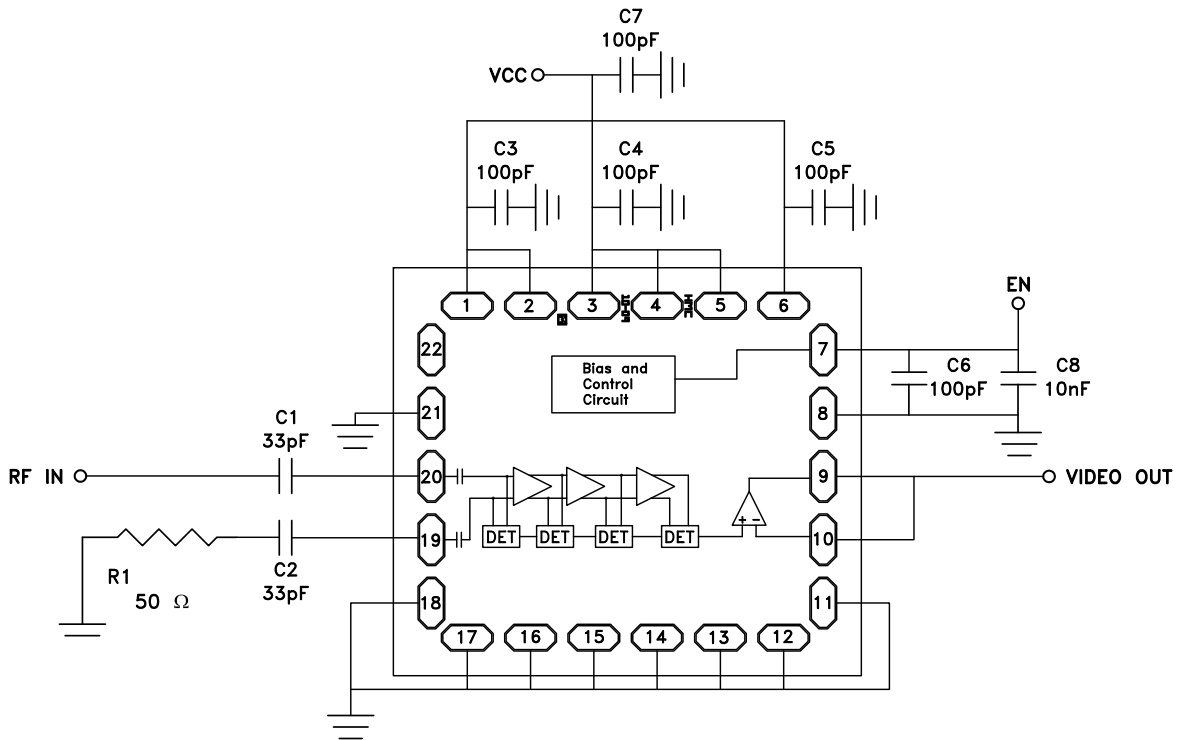

Note: Video output load should be 1K Ohm or higher.

SUCCESSIVE DETECTION LOG VIDEO AMPLIFIER (SDLVA), 0.6 - 20 GHz

Assembly Diagram

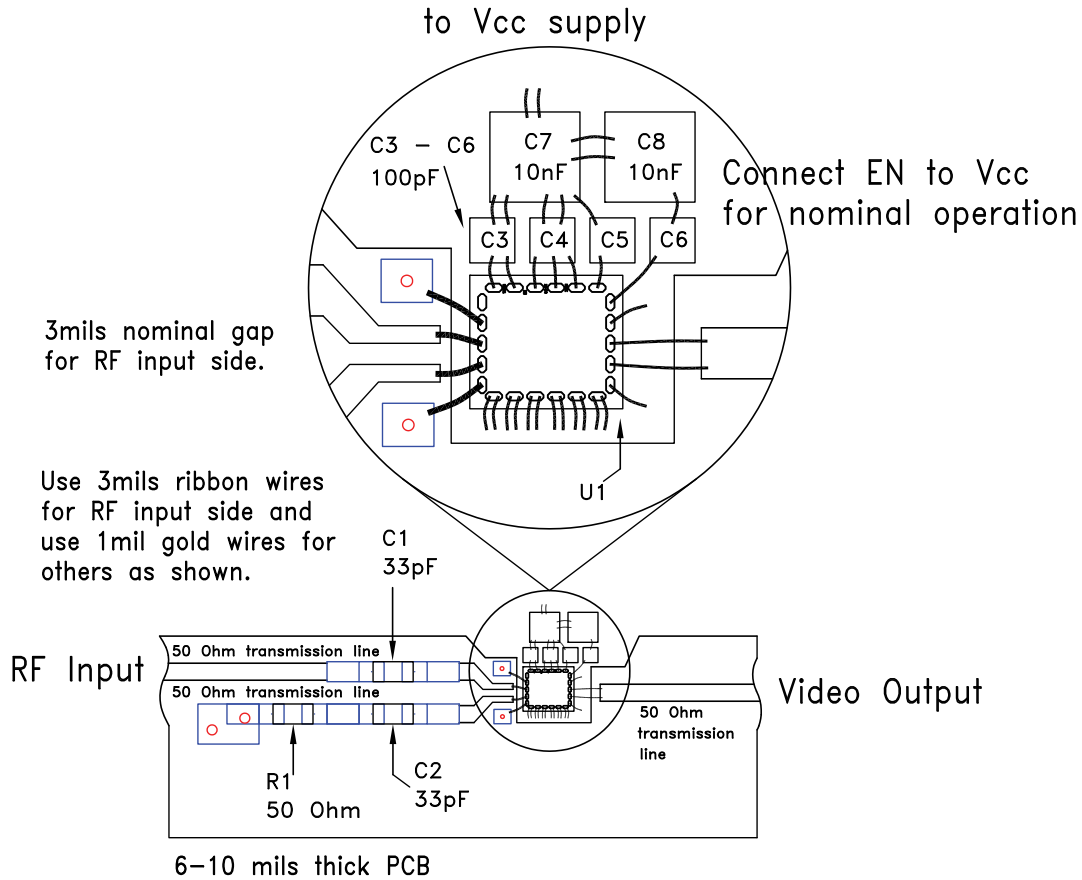

List of Materials for Assembly Diagram

| Item | Description |
|---------|--|
| C1, C2 | 33 pF Capacitor, 0402 Pkg. |
| C3 - C6 | 100 pF SLC Capacitor, SA1212BX101M16VHXF |
| C7 - C8 | 10 nF SLC Capacitor, MVB3030X103ZGH5N |
| R1 | 50 Ohm Resistor, 0402 Pkg. |
| U1 | HMC913 Die |



ELECTROSTATIC SENSITIVE DEVICE
OBSERVE HANDLING PRECAUTIONS



SUCCESSIVE DETECTION LOG VIDEO AMPLIFIER (SDLVA), 0.6 - 20 GHz

Mounting & Bonding Techniques for MMICs

The die should be attached directly to the ground plane with epoxy (see HMC general Handling, Mounting, Bonding Note).

50 Ohm Microstrip transmission lines on 0.254mm (10 mil) thick alumina thin film substrates are recommended for bringing RF to and from the chip (Figure 1).

Microstrip substrates should be placed as close to the die as possible in order to minimize bond wire length. Typical die-to-substrate spacing is 0.076mm to 0.152 mm (3 to 6 mils).

Handling Precautions

Follow these precautions to avoid permanent damage.

Storage: All bare die are placed in either Waffle or Gel based ESD protective containers, and then sealed in an ESD protective bag for shipment. Once the sealed ESD protective bag has been opened, all die should be stored in a dry nitrogen environment.

Cleanliness: Handle the chips in a clean environment. DO NOT attempt to clean the chip using liquid cleaning systems.

Static Sensitivity: Follow ESD precautions to protect against ESD strikes.

Transients: Suppress instrument and bias supply transients while bias is applied. Use shielded signal and bias cables to minimize inductive pick-up.

General Handling: The chip may be handled by a vacuum collet or with a sharp pair of tweezers.

Mounting

Epoxy Die Attach: Apply a minimum amount of epoxy to the mounting surface so that a thin epoxy fillet is observed around the perimeter of the chip once it is placed into position. Cure epoxy per the manufacturer's schedule.

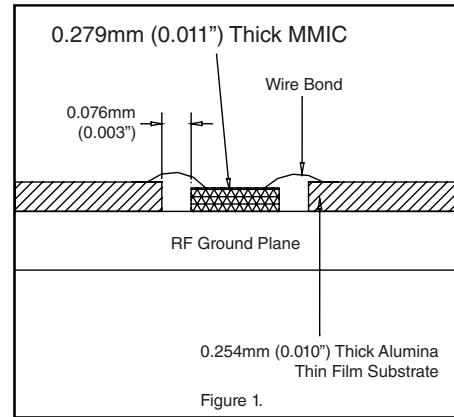

Данный компонент на территории Российской Федерации

Вы можете приобрести в компании MosChip.

Для оперативного оформления запроса Вам необходимо перейти по данной ссылке:

<http://moschip.ru/get-element>

Вы можете разместить у нас заказ для любого Вашего проекта, будь то серийное производство или разработка единичного прибора.

В нашем ассортименте представлены ведущие мировые производители активных и пассивных электронных компонентов.

Нашей специализацией является поставка электронной компонентной базы двойного назначения, продукции таких производителей как XILINX, Intel (ex.ALTERA), Vicor, Microchip, Texas Instruments, Analog Devices, Mini-Circuits, Amphenol, Glenair.

Сотрудничество с глобальными дистрибьюторами электронных компонентов, предоставляет возможность заказывать и получать с международных складов практически любой перечень компонентов в оптимальные для Вас сроки.

На всех этапах разработки и производства наши партнеры могут получить квалифицированную поддержку опытных инженеров.

Система менеджмента качества компании отвечает требованиям в соответствии с ГОСТ Р ИСО 9001, ГОСТ РВ 0015-002 и ЭС РД 009

Офис по работе с юридическими лицами:

105318, г.Москва, ул.Щербаковская д.3, офис 1107, 1118, ДЦ «Щербаковский»

Телефон: +7 495 668-12-70 (многоканальный)

Факс: +7 495 668-12-70 (доб.304)

E-mail: info@moschip.ru

Skype отдела продаж:

moschip.ru

moschip.ru_4

moschip.ru_6

moschip.ru_9